





LISTA DE PEÇAS / Pieces List / Lista de Piezas

SEQ.	REF.	DESCRIÇÃO	DESCRIPTION	DESCRIPCIÓN	MAT.PRIMA	COMP.	LARG.	ESP.	QTD.
1	320981	Rodapé frontal	Front footer.	Pie de página frontal.	MDP	1190	88	12	1
2	320982	Rodapé traseiro	Rear footer.	Pie de página trasero.	MDP	1190	88	12	1
3	320984	Trava rodapé	Footer lock.	Bloqueo de pie de página.	MDP	358	88	12	1
4	320987	Base	Base.	Base.	MDP	603	385	12	1
5	320988	Lateral esquerda	Left side.	Lado izquierdo.	MDP	1105	385	12	1
6	320989	Lateral direita	Right side.	Lado derecho.	MDP	1105	385	12	1
7	320990	Divisória	Partition.	Dividir.	MDP	1005	385	12	1
8	320991	Trava	Hangs.	Cuelga.	MDP	589	44	12	1
9	320992	Tampo	Cover.	Cubrir.	MDP	1244	415	15	1
10	320993	Fundo esquerdo	Left bottom.	Abajo a la izquierda.	HDF	1049	604	3	1
11	320994	Fundo direito	Right bottom.	Boton derecho.	HDF	1049	604	3	1
12	320995	Prateleira movel	Shelf.	Estante.	MDP	589	385	12	1
13	700500	Lateral gaveta	Side of the drawer.	Lateral del cajón.	MDP	350	100	12	12
14	320997	Contra fundo	Against background.	Contra el fondo.	MDP	540	88	12	6
15	320998	Frente gaveta	Front of the drawer.	Frente del cajón.	MDP	597	200	15	6
16	320999	Fundo gaveta	Drawer bottom.	Fondo de cajón.	HDF	562	355	3	6
17	321000	Porta	Door.	Puerta.	MDP	812	297	15	2

Vista Superior / Upper View / Vista Superior

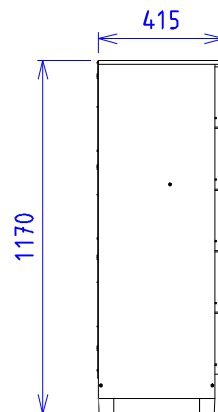
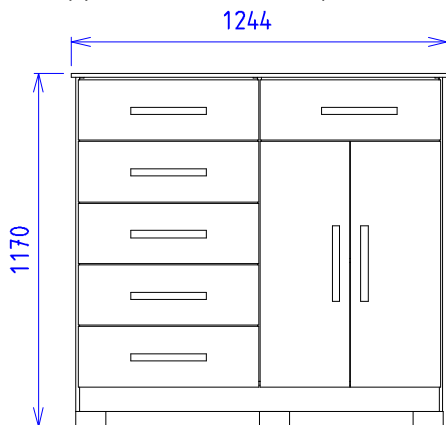
Vista Frontal / Front View / Vista Frontal



Dimensão do Produto:
1244 X 1170 X 415

INSTRUÇÃO MONTAGEM PRODUTO

Intructions to Assembly / Instrucciones de montaje

CUIDADO PARA CONSERVAÇÃO E LIMPEZA DO MÓVEL

Care to conservation and clean / Cuidados de limpieza

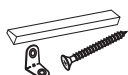

Separate as peças e acessórios de maneira organizada
Separate parts and accessories in way organized
Separe las piezas y accesorios de manera organizada

Peso máximo de carga informado refere-se a objetos distribuido de maneira uniforme sobre toda área de contato da peça



The maximum load weight informed refers to objects distributed evenly over the entire contact area of the part
Conjunto de carga máxima de peso se refere a objetos distribuidos uniformemente sobre toda el área de contacto de la pieza de trabajo.



Forrar o chão com o papelão das embalagens.
Cover the floor with the cardboard
Cubra el suelo con la embalaje de cartón



Não molhar o móvel e não expor em lugar úmido
Do not wet the mobile and do not expose in a wet place
No moje el producto y no exponer en un lugar húmedo



É necessário 01 pessoa para montar o produto
01 person is required to assemble the product
Se requiere 01 persona para ensamblar el producto.



Não expor o móvel próximo de fontes de calor.
Do not expose the mobile near heat sources
no esponga cercano de fuentes de calor

O produto deve ser a montado por um profissional qualificado
The product must be assembly by a professional
El producto debe ser ensamblado por un profesional calificado



Não usar produtos abrasivos.
Do not use abrasive products.
No utilice productos abrasivos.

Ferramentas necessárias
(não fornecidas)



Not include tools / No herramientas



Limpe com flanela limpa e seca.
Clean with dry cloth
Limpieza con un paño limpio y seco



A- 700137-Parafuso 4,5x45 (12x)
screw / tornillo



B- 700121-Parafuso 3,5x12 (40x)
screw / tornillo

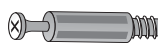

C- 700146-Parafuso minifix (12x)
Minifix screw /
Tornillo minifix



D- 700538-Cantoneira (08x)
corner / esquina



E- 700124-Parafuso 3,5x25 (40x)
screw / tornillo



F- 700120-Parafuso 3,0x12 (90x)
screw / tornillo

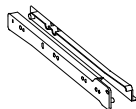

G- 700111-Corrediça (06x)
runners / corredera



H- 700547-Junção (04x)
junction / juncion



I- 700542-Cavilha 6x30 (30x)
peg / cerrojo



J- 700148-Tambor Minifix (12x)
Minifix Drum /
Tambor minifix



K- 700395-Dobradiça (04x)
700390-Calço (04x)
hinge / bisagra



L- 700171-Puxador 250 mm (08x)
Handle / Manija



M- 700516-Sache cola 20g (01x)
Glue / Goma



N- 700157-Prego (108x)
nail / clavo



O- 700441-Suporte prateleira(04x)
shelf support/soporte de estantería



P-700490-KIT COM 6 PES 01 UNID
wardrobe feet / alquiler de piso



Q- 700419-Tapa furo minifix (31x)
cover / tapa



R- 700127-Parafuso 4,0x12 (16x)
screw / tornillo

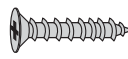

S- 700130-Parafuso 4,0x16 (04x)
screw / tornillo

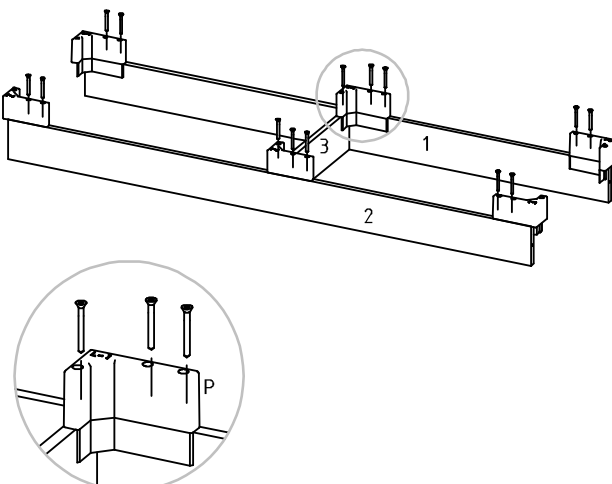
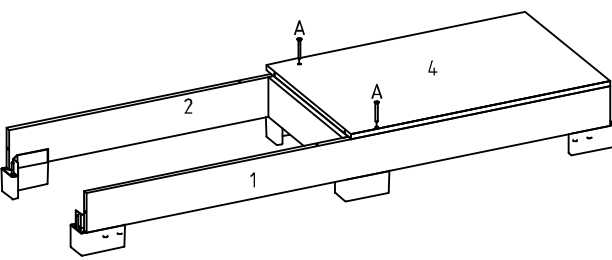
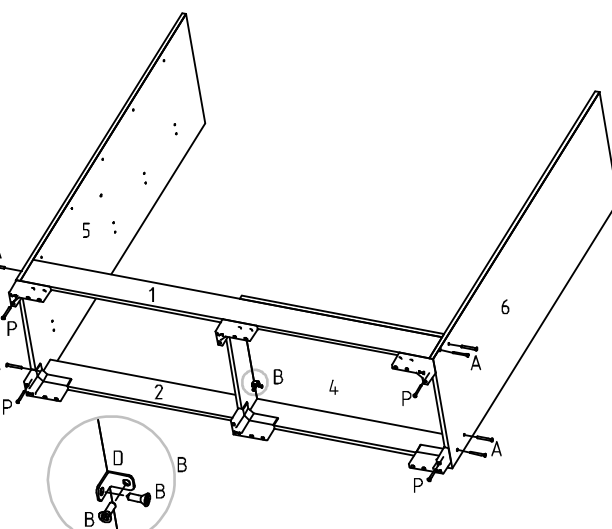
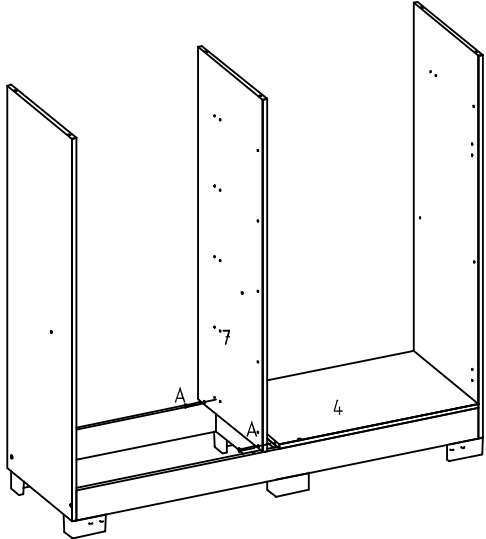
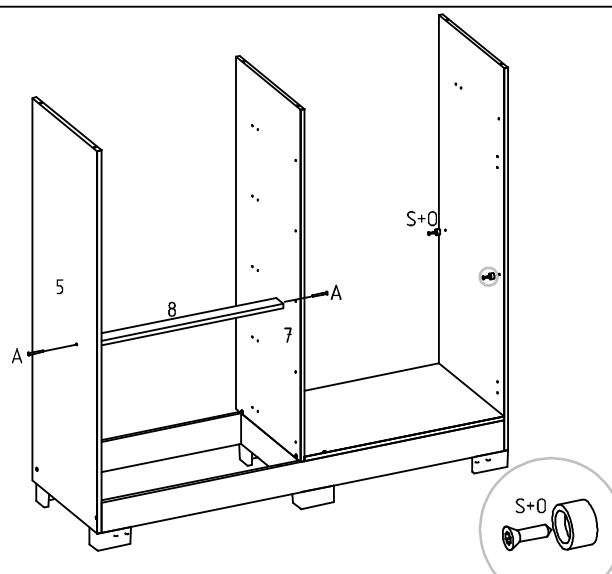
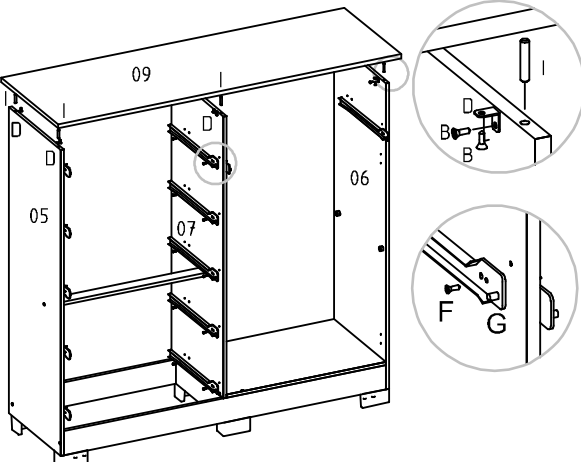
<p>01° PASSO</p> <p>01° STEP</p> <p>01° PASO</p>	<p>Fixar os pezinhos nos Rodapes e trava do Rodape.</p> <p>Fasten the feet on the Rodapes and lock the Rodape.</p> <p>Fijar los pechos en los Rodapes y traba del Rodape.</p> 	<p>02° PASSO</p> <p>02° STEP</p> <p>02° PASO</p>	<p>Fixar a peça 04 nas peças 01 e 02.</p> <p>Fasten part 04 to parts 01 and 02.</p> <p>Fijar la pieza 04 en las piezas 01 y 02.</p> 
<p>03° PASSO</p> <p>03° STEP</p> <p>03° PASO</p>	<p>Montar as peças 04, 05 e 06.</p> <p>Assemble parts 04, 05 and 06.</p> <p>Montar las piezas 04, 05 y 06.</p> 	<p>04° PASSO</p> <p>04° STEP</p> <p>04° PASO</p>	<p>Montar a peça 07 na peça 04.</p> <p>Assemble part 07 in part 04.</p> <p>Montar la pieza 07 en la pieza 04.</p> 
<p>05° PASSO</p> <p>05° STEP</p> <p>05° PASO</p>	<p>Montar a peça 08 nas peças 05 e 07.</p> <p>Assemble part 08 on parts 05 and 07.</p> <p>Montar la pieza 08 en las piezas 05 y 07.</p> 	<p>06° PASSO</p> <p>06° STEP</p> <p>06° PASO</p>	<p>Encaixar o tampo nas peças 05, 06 e 07.</p> <p>Attach the top on parts 05, 06 and 07.</p> <p>Enganche la tapa en las piezas 05, 06 y 07.</p> 

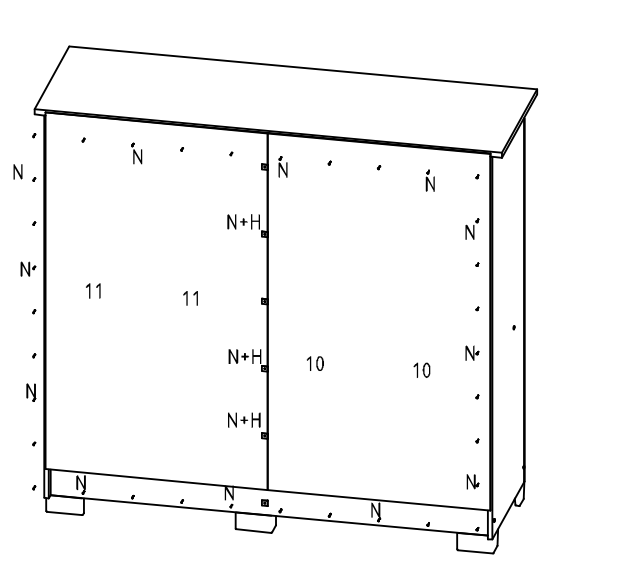
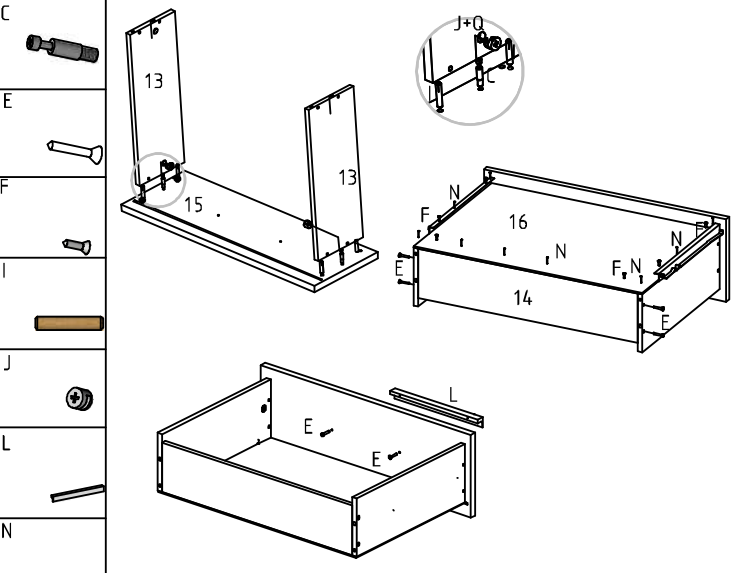
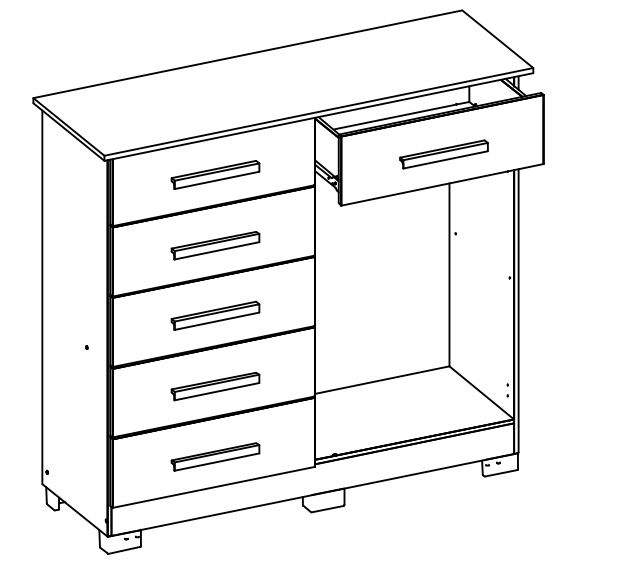
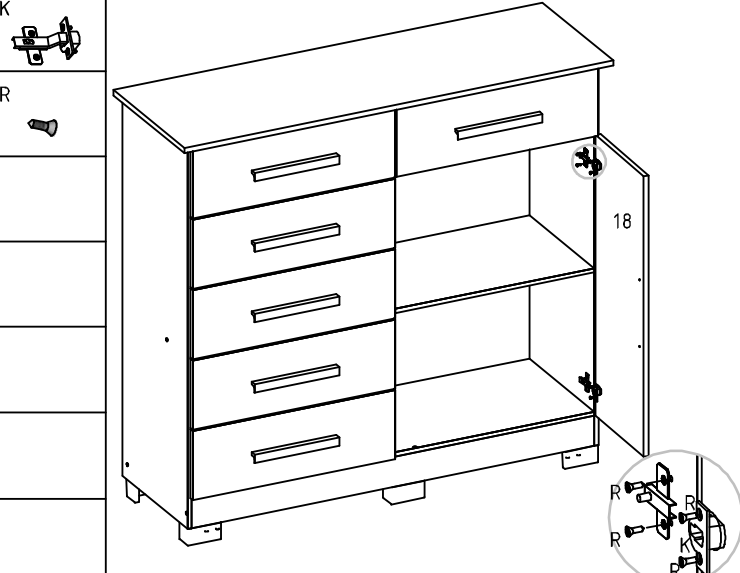
<p>07° PASSO</p> <p>07° STEP</p> <p>07° PASO</p> <p>N</p> <p>H</p>	<p>Pregar os fundos</p> <p>Nail the bottom</p> <p>Predicar los fondos</p> 	<p>Montar as Gavetas.</p> <p>Assemble the Drawers.</p> <p>Montar los cajones.</p> 
<p>09° PASSO</p> <p>09° STEP</p> <p>09° PASO</p>	<p>Encaixar as gavetas no Produto.</p> <p>Attach the drawers to the Product.</p> <p>Encaje los cajones en el producto.</p>	<p>10° PASSO</p> <p>10° STEP</p> <p>10° PASO</p>
<p>-</p>		<p>K</p> <p>R</p> 
<p>11° PASSO</p> <p>11° STEP</p> <p>11° PASO</p>	<p>Fixar o puxadores na porta.</p> <p>Secure the handles on the door.</p> <p>Fijar los tiradores en la puerta.</p>	<p>12° PASSO</p> <p>12° STEP</p> <p>12° PASO</p>
<p>E</p> <p>L</p>	