

119 - COMODA SAPATEIRA MOBI

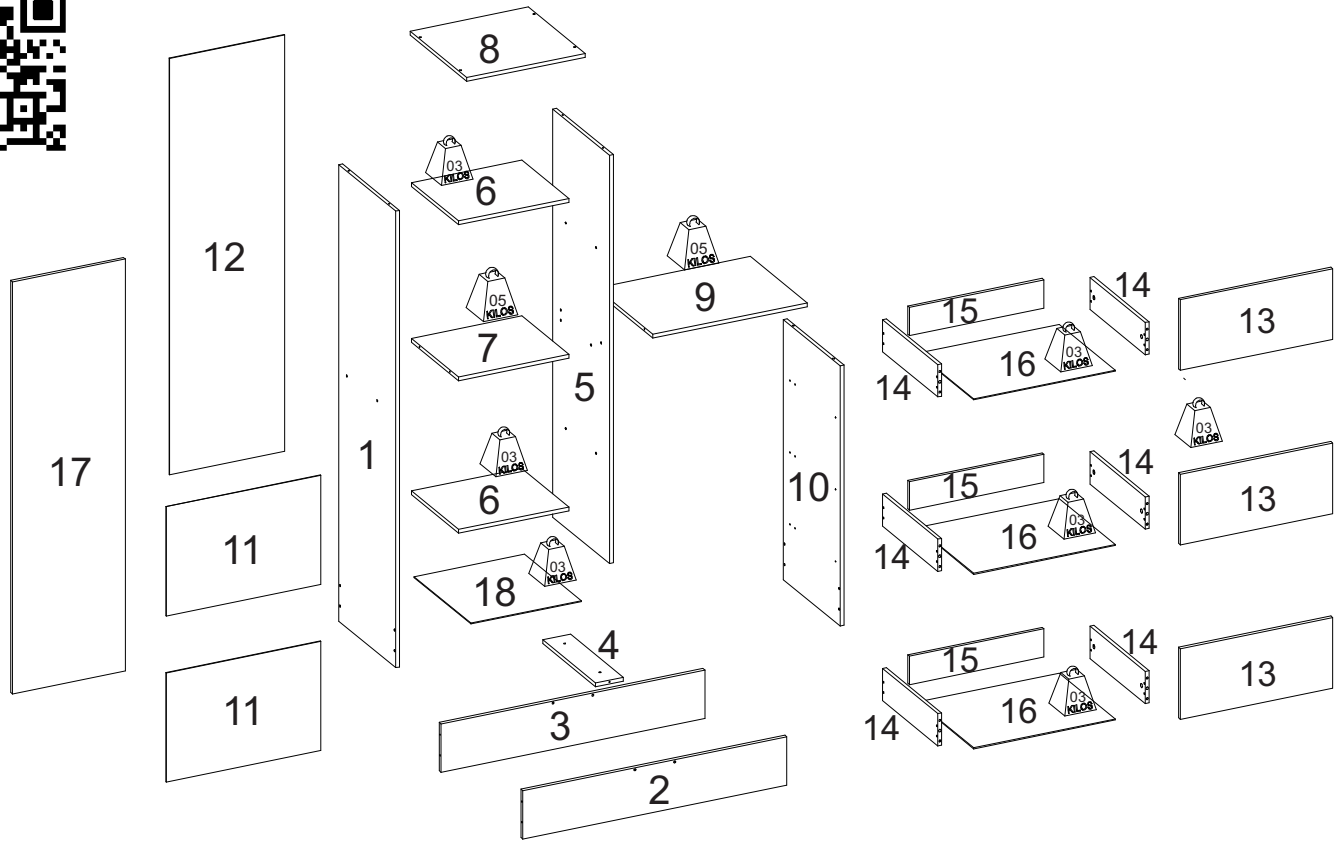



LISTA DE PEÇAS / PIECES LIST / LISTA DE PIEZAS

SEQ.	REF.	DESCRIÇÃO	DESCRIPTION	DESCRIPCIÓN	MAT.PRIMA	COMP.	LARG.	ESP.	QTD.
1	331005	Lateral esquerda	Left side.	Lado izquierdo.	MDP	1418	360	12	1
2	331006	Rodapé frontal	Front footer.	Pie de página delantero.	MDP	836	150	12	1
3	331007	Rodapé traseiro	Rear footer.	Pie de página posterior.	MDP	836	150	12	1
4	331008	Trava divisória	Partition lock.	Bloqueo de partición.	MDP	334	88	12	1
5	331009	Divisória	Partition.	Dividir.	MDP	1268	360	12	1
6	331010	Prateleira móvel	Mobile shelf.	Estante móvil.	MDP	349	298	12	2
7	331011	Prateleira fixa	Fixed shelf.	Estante fijo.	MDP	349	298	12	1
8	331012	Chapéu	Hat.	Sombrero.	MDP	375	360	12	1
9	331013	Tampo	Cover.	Cubrir.	MDP	489	360	12	1
10	331014	Lateral direita	Right side.	Lado derecho.	MDP	808	360	12	1
11	331015	Fundo	Background.	Antecedentes.	HDF	490	339	3	2
12	331016	Fundo maior	Bigger background.	Fondo más grande.	HDF	1293	365	3	1
13	331017	Frente de gaveta	Drawer front.	Frente de cajón.	MDP	483	219	12	3
14	331018	Lateral de gaveta	Drawer side.	Lado del cajón.	MDP	350	100	12	6
15	331019	Contra fundo	Against background.	contra el fondo.	MDP	426	88	12	3
16	331020	Fundo da gaveta	Drawer background.	Fondo del cajón.	HDF	448	355	3	3
17	331021	Porta	Door.	Puerta.	MDP	1279	357	12	1
18	331022	Base de hdf	hdf base.	base HDF.	HDF	360	349	3	1

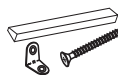
INSTRUÇÃO MONTAGEM PRODUTO
 Instructions to Assembly / Instrucciones de montaje

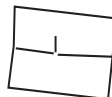
 **Separe as peças e acessórios de maneira organizada**
 Separate parts and accessories in way organized
 Separe las piezas y accesorios de manera organizada

 **Forrar o chão com o papelão das embalagens.**
 Cover the floor with the cardboard
 Cubra el suelo con la embalaje de cartón

 **É necessário 01 pessoas para montar o produto**
 01 people are required to assemble the product
 Se requieren 01 personas para ensamblar el producto

O produto deve ser a montado por um profissional qualificado
 The product must be assembly by a professional
 El producto debe ser ensamblado por un profesional calificado

Ferramentas necessárias (não fornecidas)

Not include tools / No herramientas



CUIDADO PARA CONSERVAÇÃO E LIMPEZA DO MÓVEL
 Care to conservation and clean / Cuidados de limpieza

Peso máximo de carga informado refere-se a objetos distribuido de maneira uniforme sobre toda área de contato da peça



The maximum load weight informed refers to objects distributed evenly over the entire contact area of the part
 Conjunto de carga máxima de peso se refiere a objetos distribuidos uniformemente sobre toda el área de contacto de la pieza de trabajo.



Não molhar o móvel e não expor em lugar úmido
 Do not wet the mobile and do not expose in a wet place
 No moje el producto y no exponer en un lugar húmedo



Não expor o móvel próximo de fontes de calor.
 Do not expose the mobile near heat sources
 no exponga cercano de fuentes de calor



Não usar produtos abrasivos.
 Do not use abrasive products.
 No utilice productos abrasivos.



Limpe com flanela limpa e seca.
 Clean with dry cloth
 Limpieza con un paño limpio y seco

LISTA DE ACESSÓRIOS E FERRAGENS / ACCESSORIES AND HARDWARE / ACCESORIOS Y HARDWARE



A - 700137-Parafuso 4,5x45 (22x)
 screw / tornillo



B- 700124-Parafuso 3,5x25 (20x)
 screw / tornillo

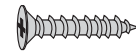

C- 700130-Parafuso 4,0x16 (1x)
 screw / tornillo



D- 700120-Parafuso 3,0 x12 (53x)
 screw / tornillo



E- 700126-Parafuso 4,0 x12 (36x)
 screw / tornillo



F- 700542-Cavilha 6x30 (14x)
 peg / cerrojo



G- 700146-Parafuso minifix (6x)
 Minifix screw /
 Tornillo minifix



H- 700148-Tambor Minifix (6x)
 Minifix Drum /
 Tambor minifix



I- 700157-Prego (77x)
 nail / clavo



J- 700539-Cantoneira (2x)
 corner / esquina



K- 700395-Dobradiça (3x)
 700390-Calço (3x)
 hinge / bisagra



L - 700440-Suporte Prateleira (8x)
 Shelf support / soporte



M- 700547-Junção (4x)
 junction / juncion



N- 700419-Tapa furo (14x)
 cover / tapa



O- 702138-Perfil H (1x)
 handle / manija

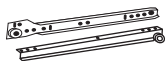

P - 700111 - Corrediça (3x)
 runners / corredera



Q- 700230 - Pé PVC (4x)
 PVC foot / Pie de PVC



R- 700767 - Puxador (4x)
 Handle / Manija



S - 700441 - Suporte prateleira(1x)
 Support/apoyo



T- 701239 - Calço plastico
 dobradiça (3x)
 chock / cuña



U - 700516 - Sache
 cola 20g (1x)
 Glue / Goma



V- 700419-Tapa furo (15x)
 cover / tapa

01° PASSO - Fixar os acessórios nas peças 1,5 e 10

01° STEP - Fix the accessories to parts 1,5 and 10

01° PASO - Fije los accesorios en las partes 1,5 y 10

C



D



L



P



S

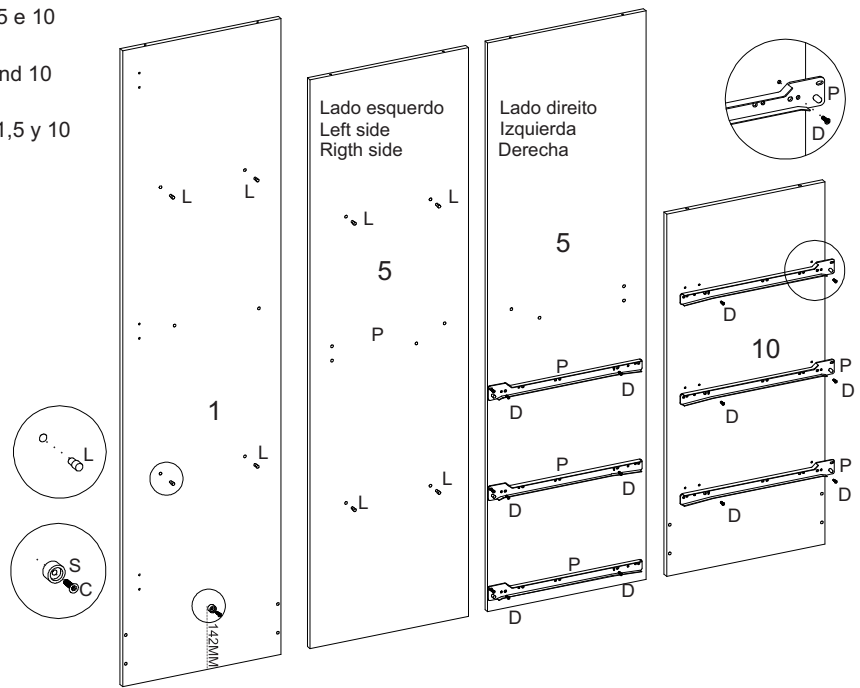

02° PASSO - Fixar peça 1 nas peças 2 e 3. Fixar peça 4 nas peças 2 e 3

02° STEP - Fix part 1 to parts 2 and 3. Fix part 4 to parts 2 and 3

02° PASO - Fijar la parte 1 a las partes 2 y 3. Fijar la parte 4 a las partes 2 y 3

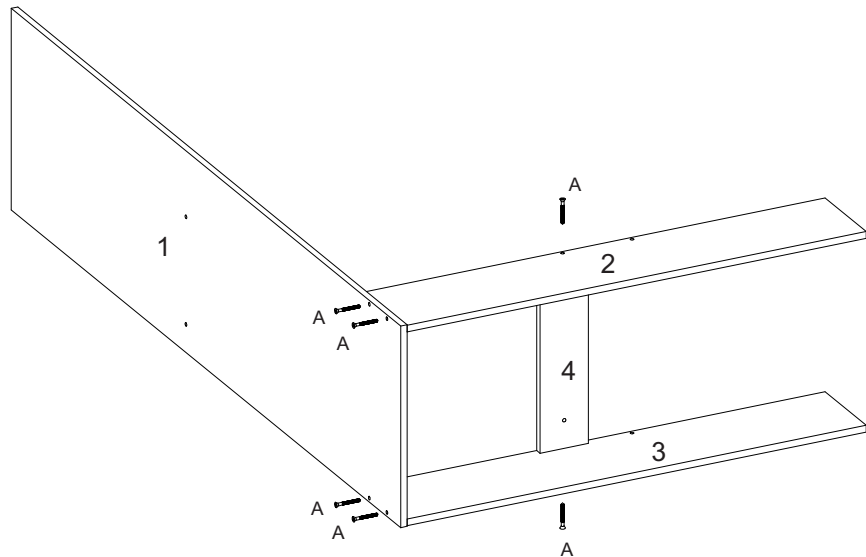
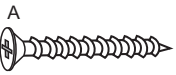

03° PASSO - Fixar peça 4 na peça 5

03° STEP - Fix part 4 to part 5

03° PASO - Fijar la parte 4 a la parte 5

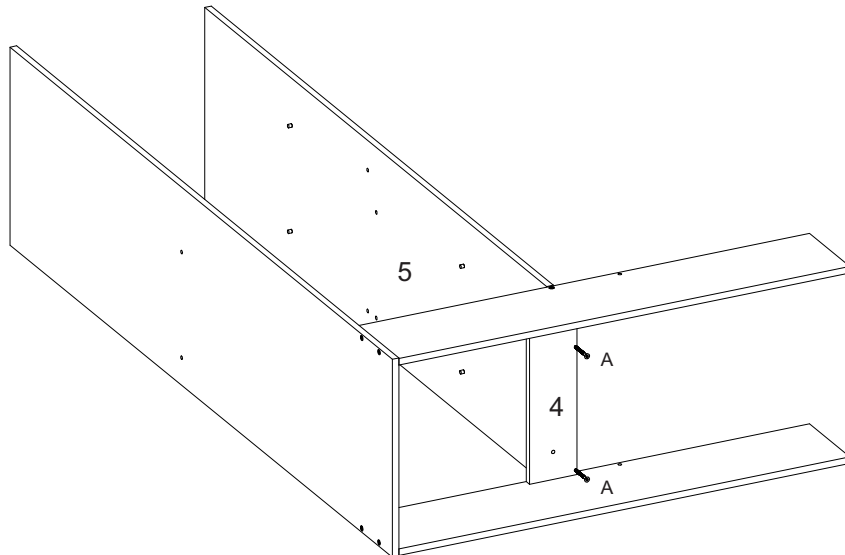

04° PASSO - Fixar peça 7 nas peças 1 e 5. Fixar peça 8 nas peças 1 e 5

04° STEP - Fix part 7 to parts 1 and 5. Fix part 8 to parts 1 and 5

04° PASO - Fijar la parte 7 a las partes 1 y 5. Fijar la parte 8 a las partes 1 y 5

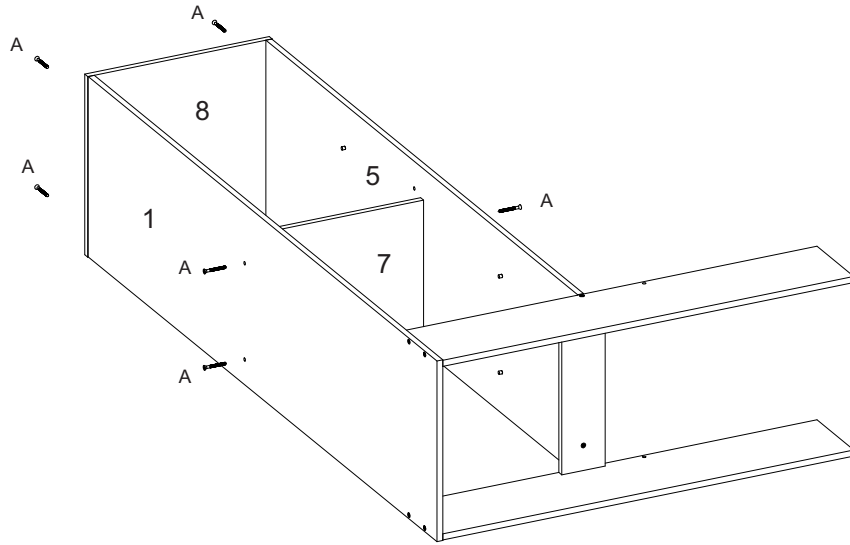

05° PASSO - Fixar peça 10 nas peças 2 e 3. Fixar o acessório (F) na peça 10

05° STEP - Fix part 10 to parts 2 and 3. Fix the accessory (F) to part 10

05° PASO - Fijar la parte 3 a las partes 1 y 2. Fijar lo accesorio (F) en la parte 10

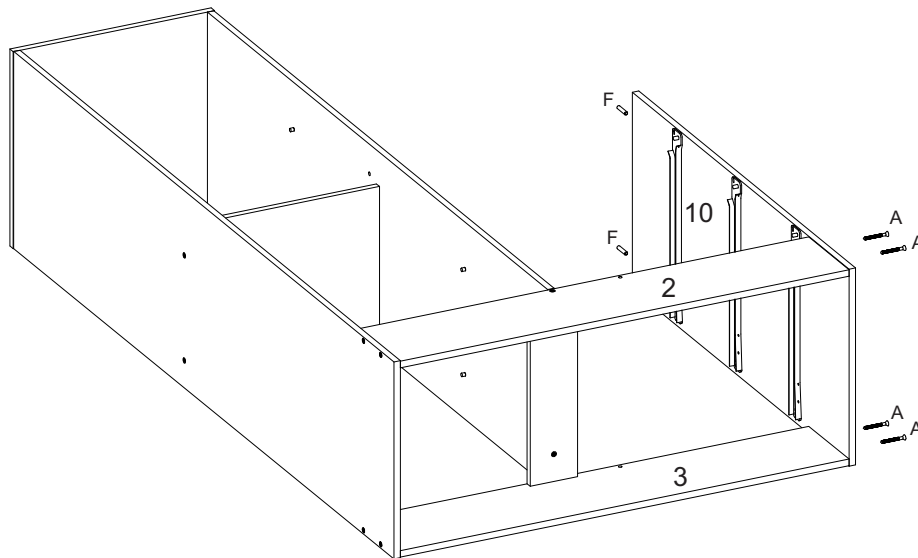

06° PASSO - Fixar peça 9 nas peças 5 e 10. Fixar o acessório J e Q como indicado

06° STEP - Fix part 9 to parts 5 and 10. Fix the accessory J and Q as shown

06° PASO - Fijar la parte 9 a las partes 5 y 10. Fijar el accesorio J y Q como se muestra

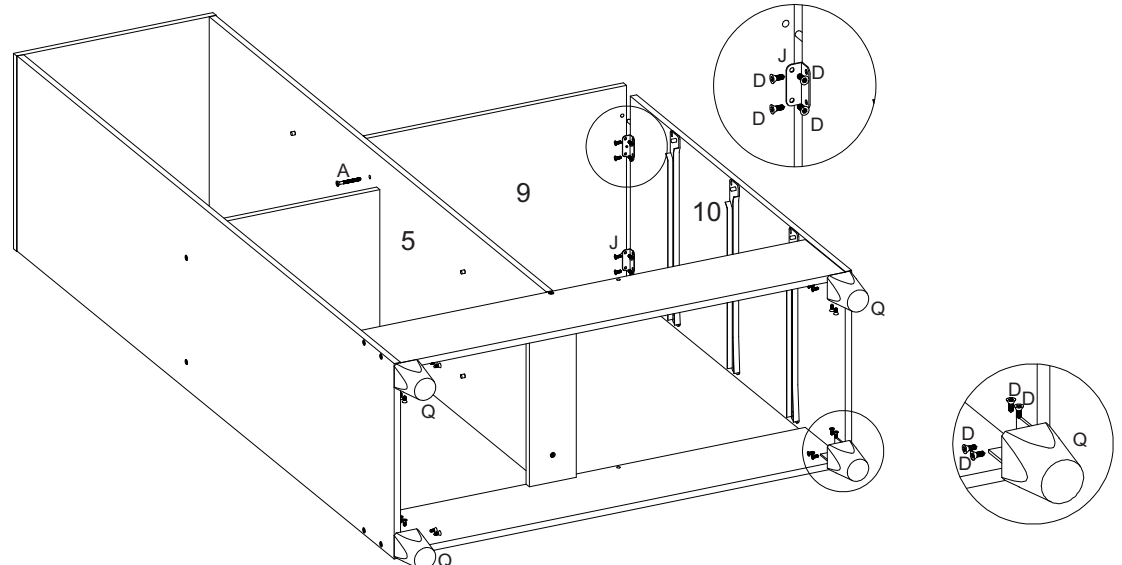

07º PASSO - Fixar peças 11 e 12 utilizando acessórios indicados

07º STEP - Fix parts 11 and 12 using indicated accessories

07º PASO - Fijar las piezas 11 y 12 utilizando los accesorios indicados

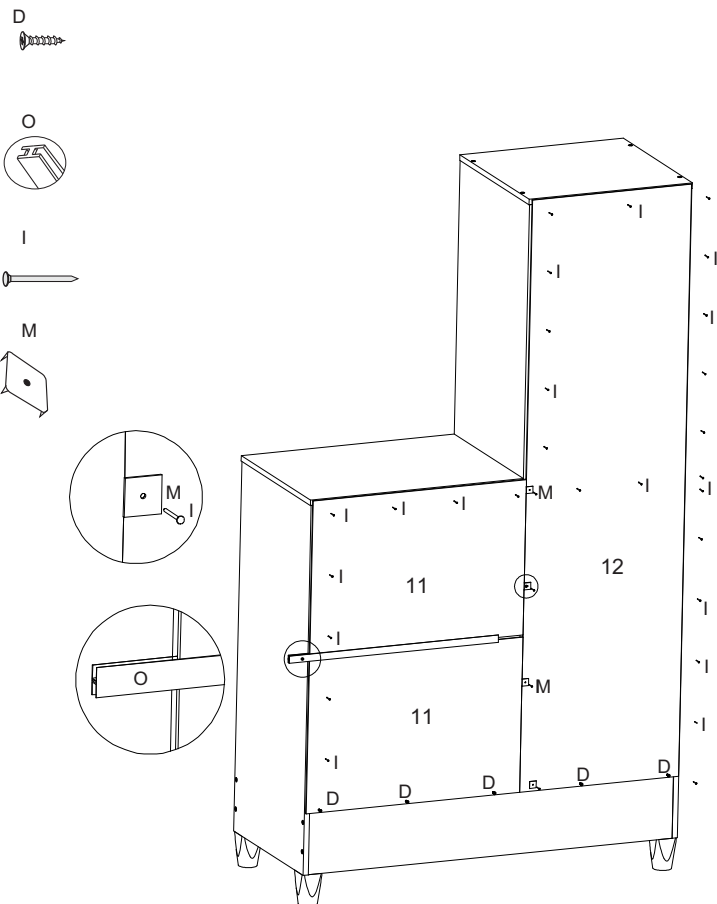

08º PASSO - Fixar peça 17 utilizando acessórios indicados

08º STEP - Fix part 17 using indicated accessories

08º PASO - Fijar la pieza 17 utilizando los accesorios indicados

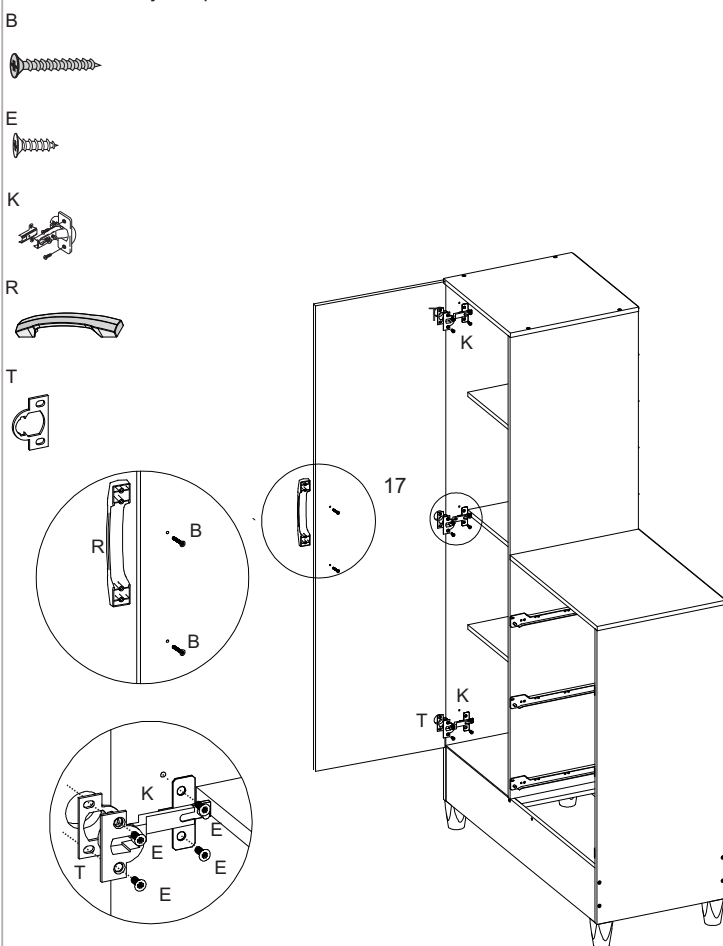

09º PASSO - Fixar as peças 13 e 15 nas peças 14

09º STEP - Fix parts 13 and 15 to parts 14

09º PASO - Fijar las piezas 13 y 15 a las piezas 14

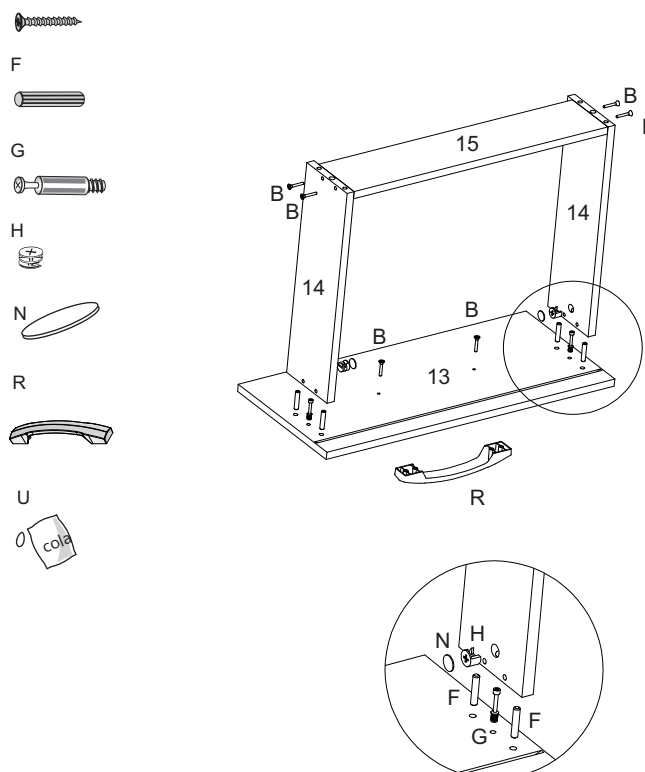

10º PASSO - Fixar peça 16 nas peças 14 e 15

10º STEP - Fix part 16 to parts 14 and 15

10º PASO - Fijar la parte 16 a las partes 14 y 15

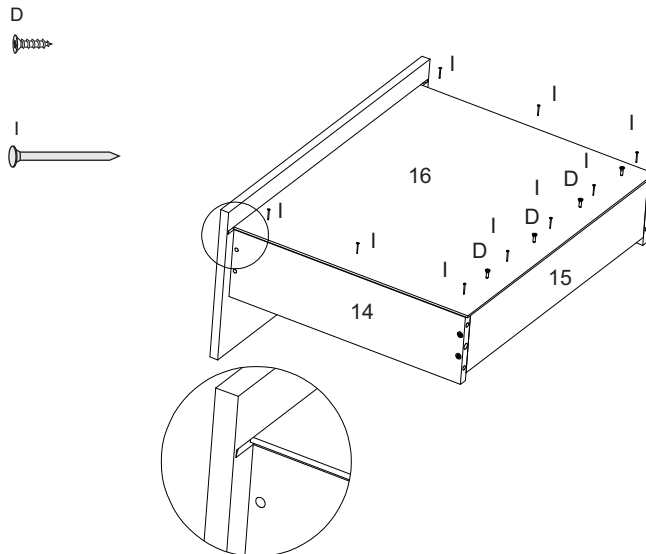

11º PASSO - Fixar o acessório P nas peças 16 e 14

11º STEP - Fix accessory P to parts 16 and 14

11º PASO - Fijar el accesorio P a las piezas 16 y 14

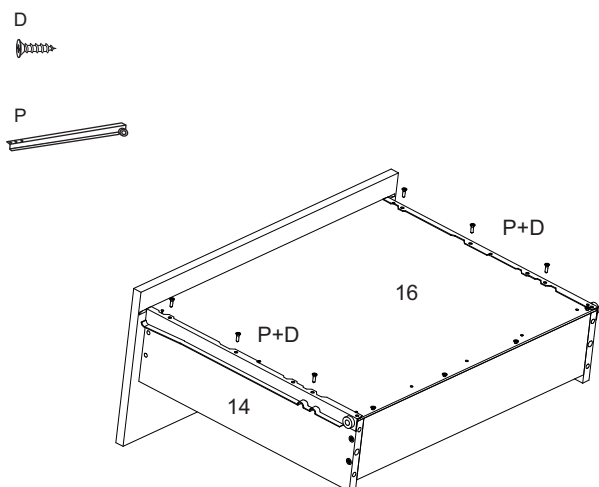

12º PASSO - Fixar acessórios indicados

12º STEP - Fix indicated accessories

12º PASO - Fijar los accesorios indicados

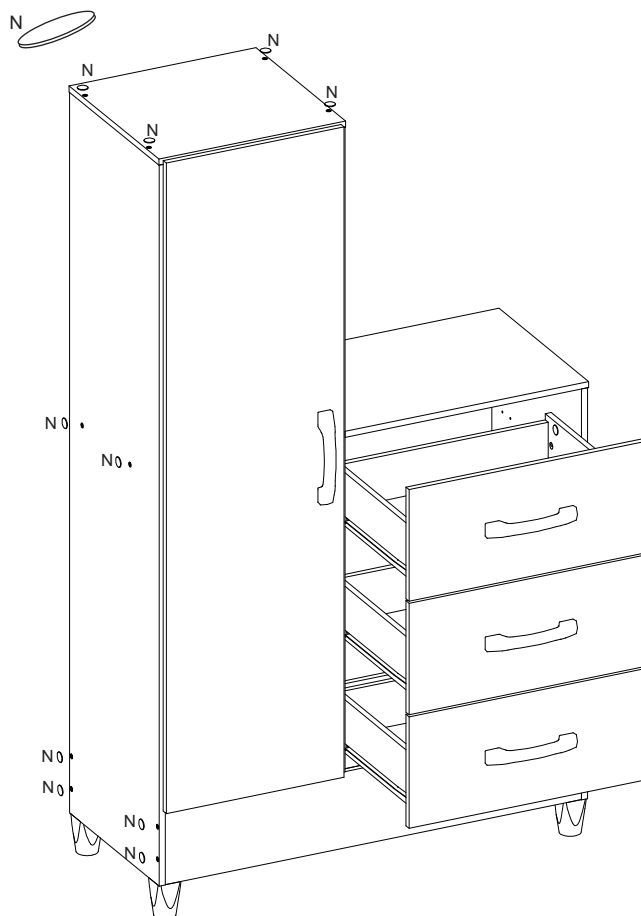

Montagem para o produto que contem espelhos

Assembly for products with mirrors

Montaje para productos con espejos

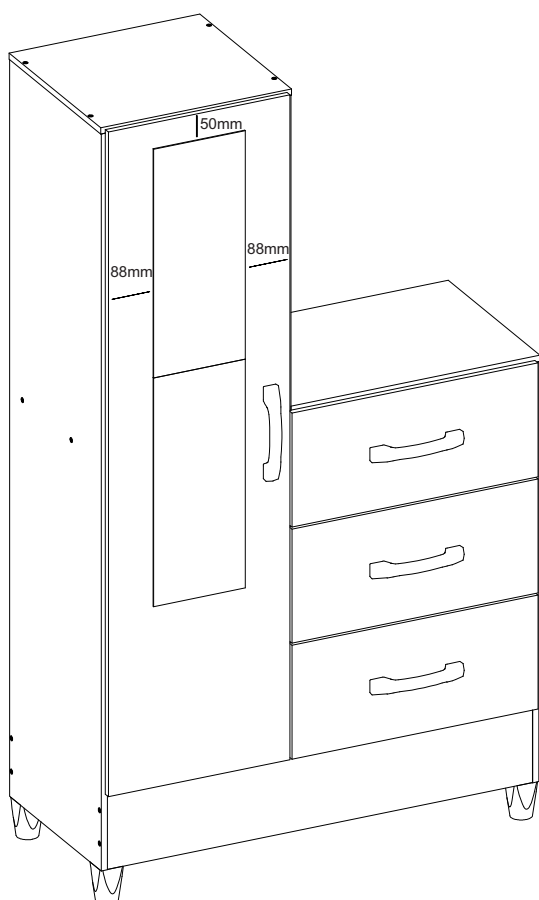

Aspecto final

Final appearance

Aspecto final del producto

