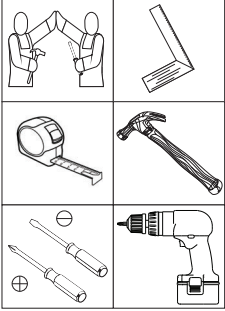
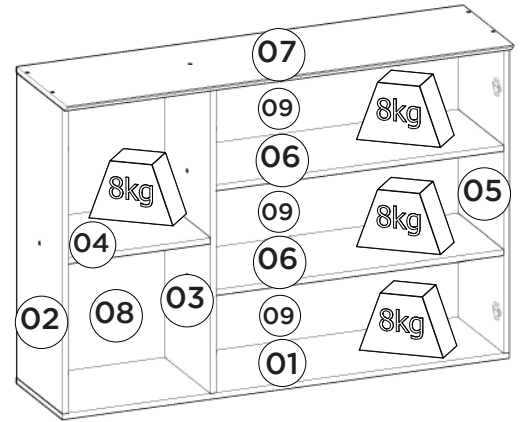
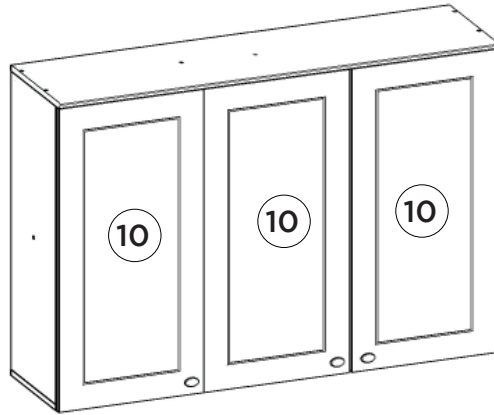

**HENN**Ind. e Com. de Móveis Henn  
Mondai - SC - Brasil

☎ +55 49 3674.3500

📷 @moveishenn  
www.henn.com.br**INSTRUÇÕES DE MONTAGEM****INSTRUCCIONES DE MONTAJE  
ASSEMBLY INSTRUCTIONS****Cozinhas Compacta 3 Peças Geladeira Emily**Referência/Cor  
c CE574-05 Branco HPRequisitos para montagem  
Requisitos para la montaje  
Assembly RequirementsImagens meramente ilustrativas  
Imágenes meramente ilustrativas  
Images for illustration onlyPesos máximos recomendados com carga distribuída  
Peso máximo recomendado con la carga distribuida  
Recommended maximum weight with distributed load.**Lista de Peças | Lista de piezas | List of parts**

Item	Caixa Caja Box	Qtd Ctd Qty	Descrição   Descripción   Description	Medidas (mm)   Dimensions (mm)   Size (measurements) (mm)
01	1/1	01	Base   Base   Base	1200x295x15
02	1/1	01	Lateral Esquerda   Lateral Izquierda   Right Left	800x295x15
03	1/1	01	Divisão   División   Division	800x295x15
04	1/1	01	Prateleira Menor   Estante Pequeño   Smaller Shelf	382x295x15
05	1/1	01	Lateral Direita   Lateral Derecha   Right Side	800x295x15
06	1/1	02	Prateleira   Estante   Shelf	772x295x15
07	1/1	01	Tampo   Tapa   Top	1200x322x15
08	1/1	01	Fundo Lateral   Fondo Lateral   Lateral Background	824x401x3
09	1/1	03	Fundo   Fondo   Bottom	791x274x3
10	1/1	03	Porta   Puerta   Door	813x396x15

**AVISO**Para limpeza de seu móvel,  
use uma flanela seca ou  
umedecida, e não utilize  
produtos químicos que  
possam danificar seu  
produto.**SISTEMA DE MONTAGEM**O sistema de montagem  
dos produtos, funciona  
de acordo com a ordem  
crescente dos números  
indicados no desenho.  
Ex: 01, 02, 03, 04... até a  
conclusão da montagem.**ADVERTENCIA**Para limpieza de su móvil,  
use una flanela seca  
o húmeda, y no utilice  
productos químicos que  
puedan dañar su producto.**Ferragens | Herrajes | Hardware**

<b>A</b>  Parafuso 5,0x50mm FLA. Tornillo 5,0x50mm FLA. Screw 5.0x50mm FLA.	<b>B</b>  Parafuso 3,5x40mm CHT. Tornillo 3,5x40mm CHT. Screw 3.5x40mm CHT.	<b>C</b>  Parafuso 3,5x14mm FLA. Tornillo 3,5x14mm FLA. Screw 3.5x14mm FLA.	<b>D</b>  Parafuso M4x20mm CHT. ZB Tornillo M4x20mm CHT. ZB Screw M4x20mm CHT. ZB	<b>E</b>  Cavilha 8x25mm Cinta 8x25mm Dowel 8x25mm	<b>F</b>  Calço Removível Calzado extraíble Removable Shim
<b>G</b>  Dobradilha SlideOn Baixa Amortecedor 35mm Bisagra SlideOn Baja Amortiguador 35mm Low SlideOn Hinge 35mm Shock Absorber	<b>H</b>  Puxador Pontual PZ14 Oval Tirador Puntual PZ14 Oval PZ14 Oval Point Knob	<b>I</b>  Bucha plástica 8mm Bucha de plástico 8mm 8mm plastic bushing	<b>J</b>  Suporte de fixação Soporte de fijación Mounting bracket	<b>K</b>  Proteção para cantoneira Ángulo de protección Protection angle	<b>L</b>  Parafuso União 30mm Tornillo Unión 30mm Union Screw 30mm
<b>M</b>  Giz de correção Tiza de corrección Chalk of correction	<b>N</b>  Sachê de cola Bolsa de pegamento Glue bag	<b>O</b>  Adesivo tapa parafuso 10mm Adhesivo tapón de tornillo 10mm Bolt cover adhesive 10mm	<b>P</b>  Fixador de fundos Fijador de fondos Bottom fixer	<b>Q</b>  Prego 10x10mm Clavo 10x10mm Nail 10x10mm	<b>R</b>  Etiqueta resinada Henn Etiqueta resinada Henn Henn resin label

**SISTEMA DE MONTAJE**El sistema de montaje de  
los productos funciona  
de acuerdo con el orden  
crescente de los números  
indicados en el dibujo. Ej.:  
01, 02, 03, 04... hasta la  
conclusión del montaje.**NOTICE**To clean your furniture, use  
a dry or wet cloth, and do  
not use chemicals that may  
damage your product.O parafuso (L) deve ser usada  
somente quando este módulo for  
acoplado a outro módulo componível  
Henn.El tornillo (L) se debe utilizar sólo  
cuando el módulo está conectado a  
otro módulo componible Henn.The screw (L) should be used only  
when this module is attached to  
another Henn modular module.**RECOMENDAÇÃO**

Para fixar o móvel na parede usar o suporte de fixação (J), o parafuso 3,5x14mm FLA (C), a Bucha 8mm (I) e o parafuso 5,0x50mm FLA (A).

**RECOMENDACIÓN**

Para conectar el móvil a la pared con el soporte (J), tornillo 3,5 x14mm FLA (C), el casquillo de 8 mm (I) y el 5,0 x50mm tornillo FLA (A).

**RECOMMENDATION**

To fix the furniture to the wall use the fixing bracket (J), the 3.5x14mm FLA (C) screw, the 8mm bushing (I) and the 5.0x50mm FLA (A).

**ASSEMBLY SYSTEM**

The products' assembly system works according to the increasing order of the indicated numbers. For example: 01, 02, 03, 04 ... to the end of the assembly.

1º

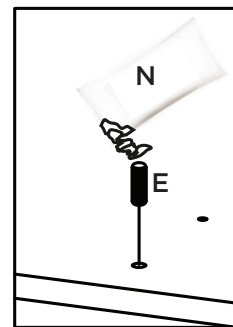
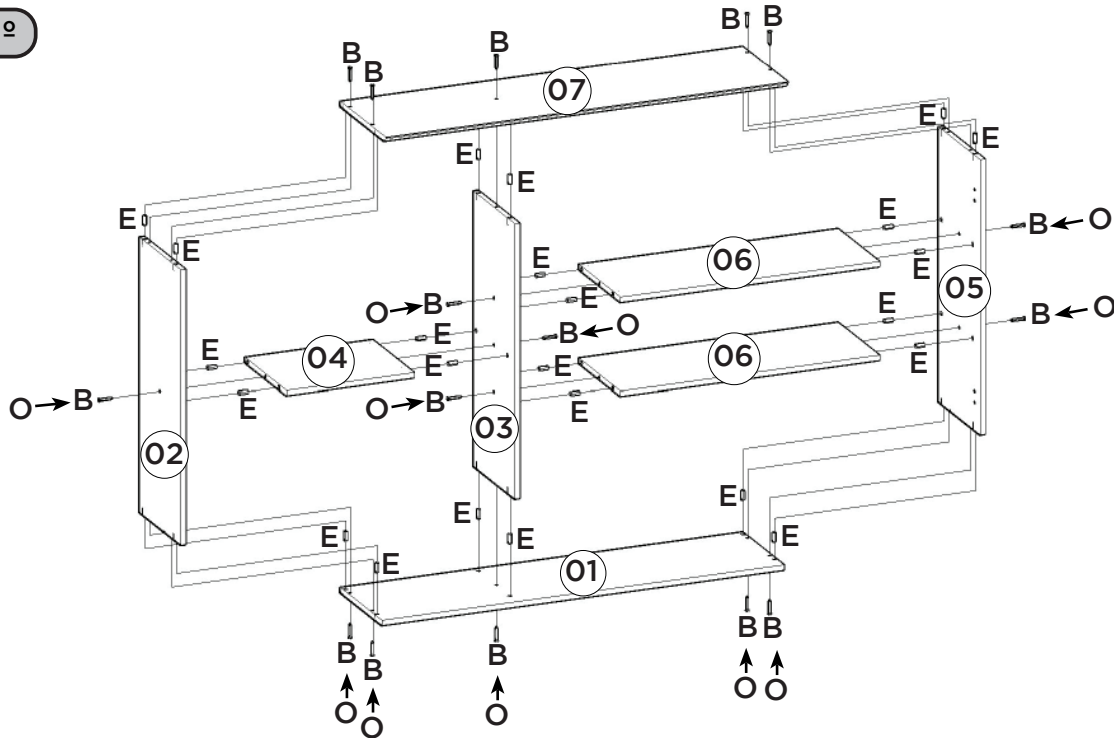

Utilizar o sachê de cola (N) em todas as cavilhas (E) do produto.

Con el pegamento sobre (N) en todos los pernos (E) producto.

Use the glue sachet (N) on all the pegs (E) of the product.

2º

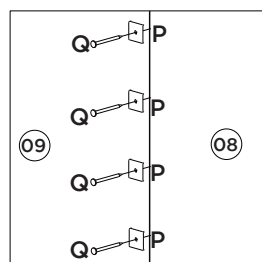
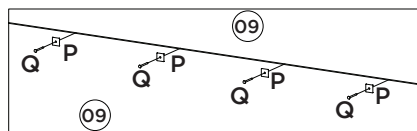
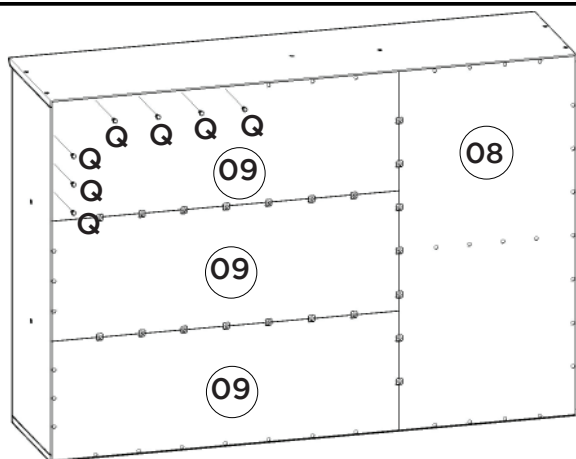

3º

Para saber mais sobre como fixar o móvel de maneira correta, acesse:

Para obtener más información sobre cómo arreglar los muebles correctamente, visite:

To learn more about how to fix the furniture correctly, visit:



<http://bit.ly/guia-de-fixacao-henn>



Imprescindível a fixação do produto na parede.

Es imprescindible la fijación del producto en la pared.

Indispensable to fix the product on the wall.

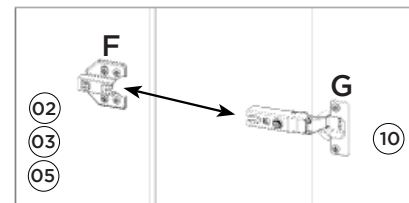
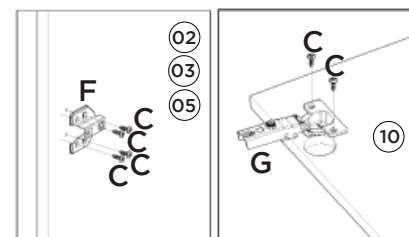
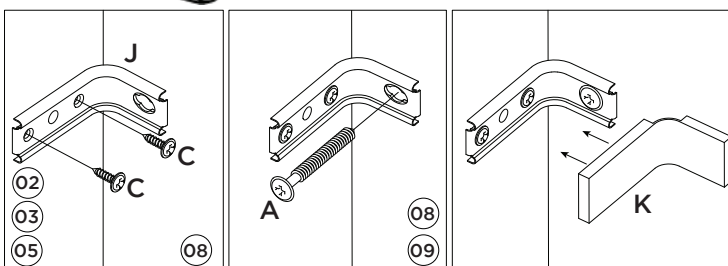

Video: Instalar e regular Dobradiças

Video: Instale y ajuste las bisagras

Video: Install and adjust hinges

Para colocação dos puxadores, é necessário fazer a furação passante, com Broca de 5mm.

Para la colocación de las asas, es necesario perforar a través, con una broca de 5mm.

To place the handles is necessary to make the through hole, drill 5mm.

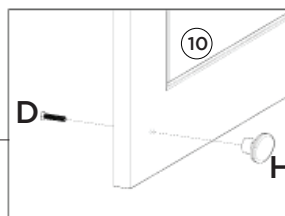
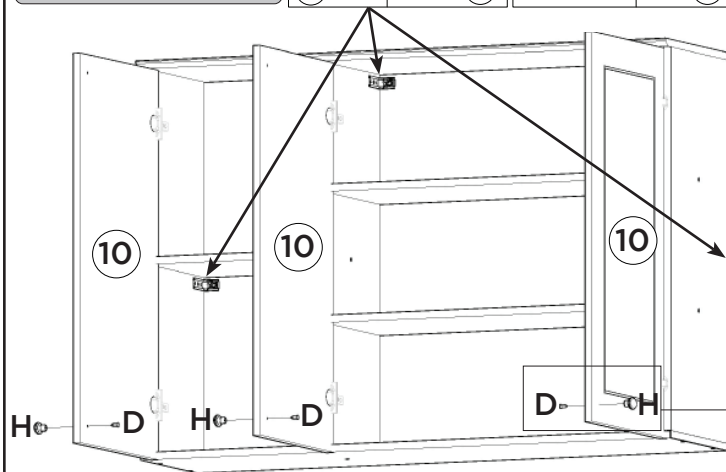

# HENN

Ind. e Com. de Móveis Henn  
Mondaí - SC - Brasil

+55 49 3674.3500

@moveishenn  
www.henn.com.br

## INSTRUÇÕES DE MONTAGEM

INSTRUCCIONES DE MONTAJE  
ASSEMBLY INSTRUCTIONS

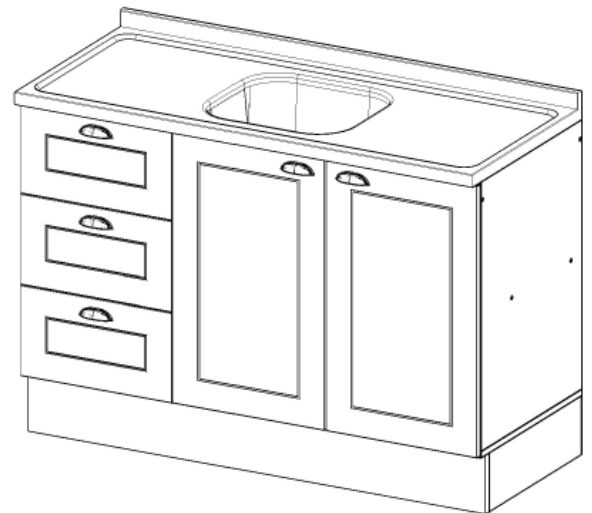
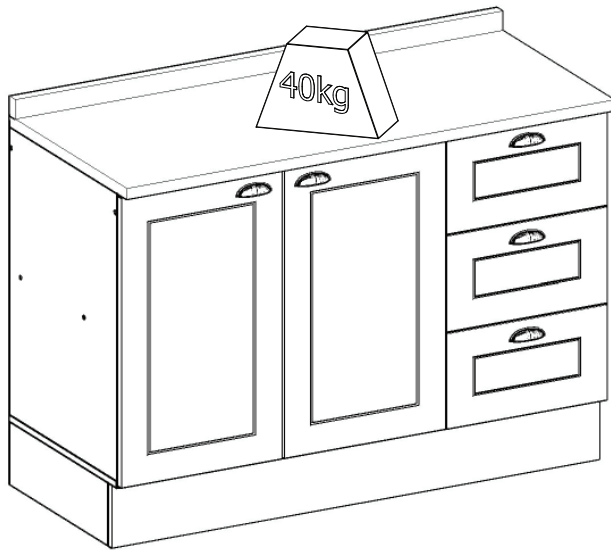
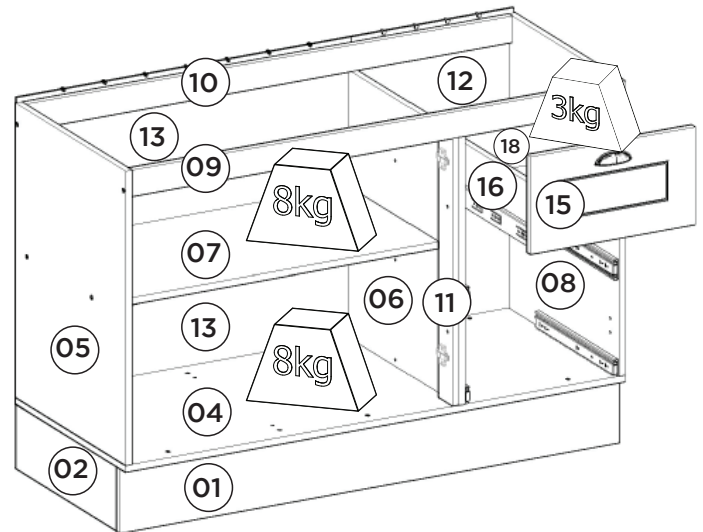
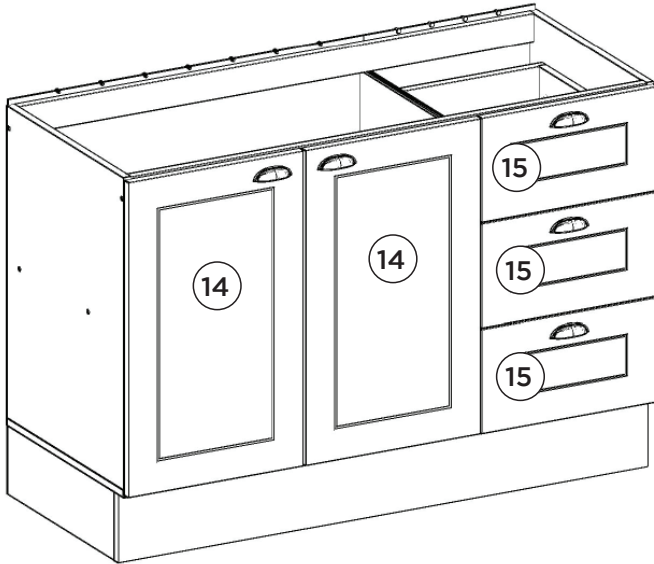

1º

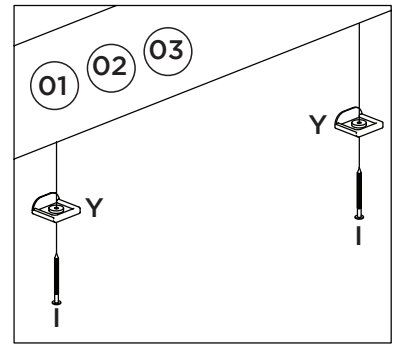
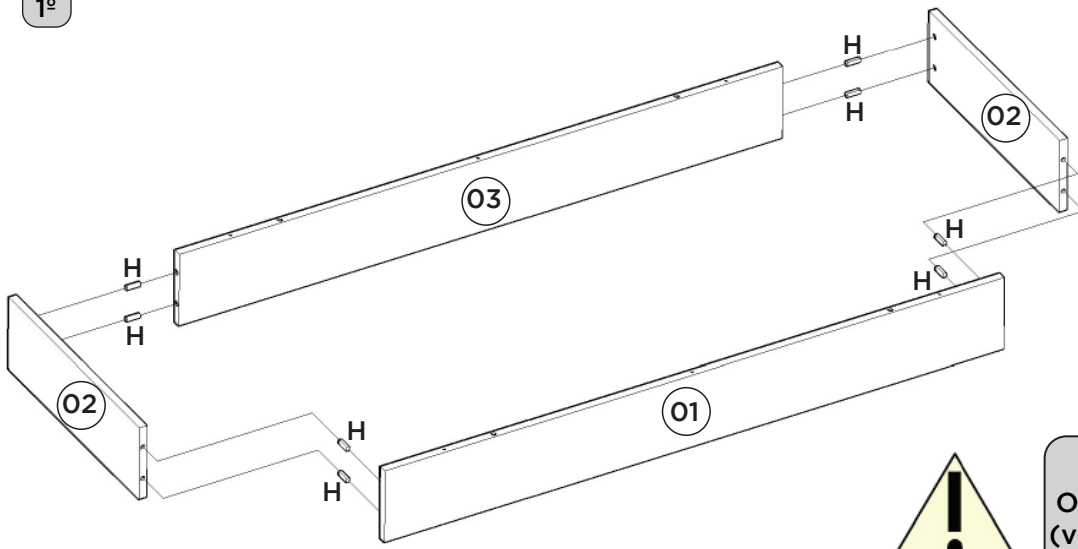

**OPCIONAL:**  
 O945-121 Kit Pé Cônico 145mm (vendido separadamente). Caso opte em colocar pé no produto, utilizar as pré-furações que possui na Base e fixá-lo com o Parafuso que consta no Kit.

**OPCIONAL:**  
 O945-121 Kit Pie Cónico 145mm (se vende por separado). Si opta por colocar pie en el producto, utilizar las pre-huracuras que tenga en la Base y fijarlo con el Tornillo que consta en el Kit.

**OPTIONAL:**  
 O945-121 Tapered Foot Kit 145mm (sold separately). If you choose to put foot in the product, use the pre-drillings in the Base and fix it with the Screw included in the Kit.

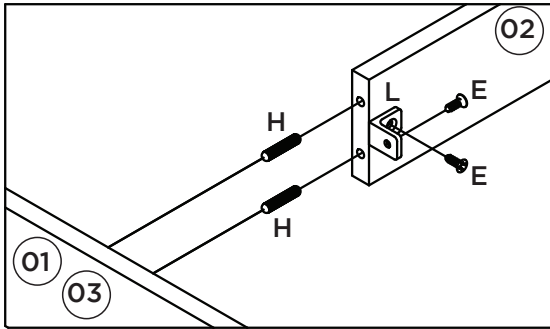

2º

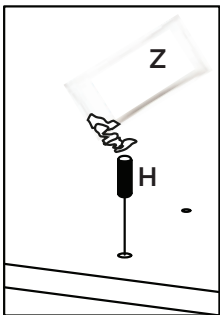

- Utilizar o sachê de cola (Z) em todas as cavilhas (H) do produto.
- Con el pegamento sobre (Z) en todos los pernos (H) producto.
- Use the glue sachet (Z) on all the pegs (H) of the product.

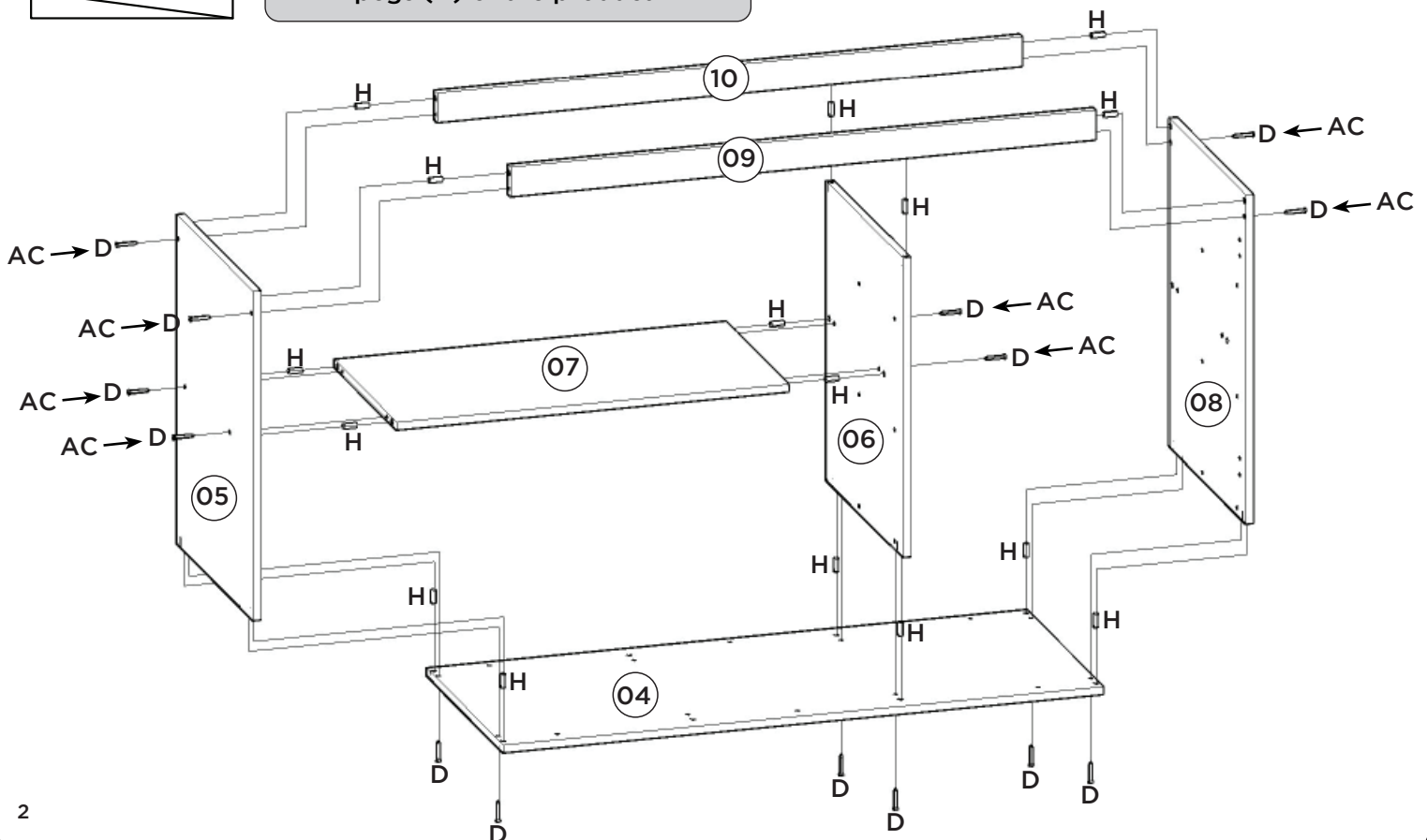

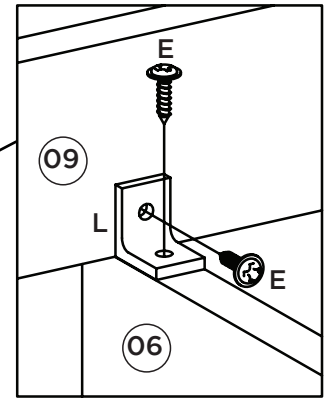
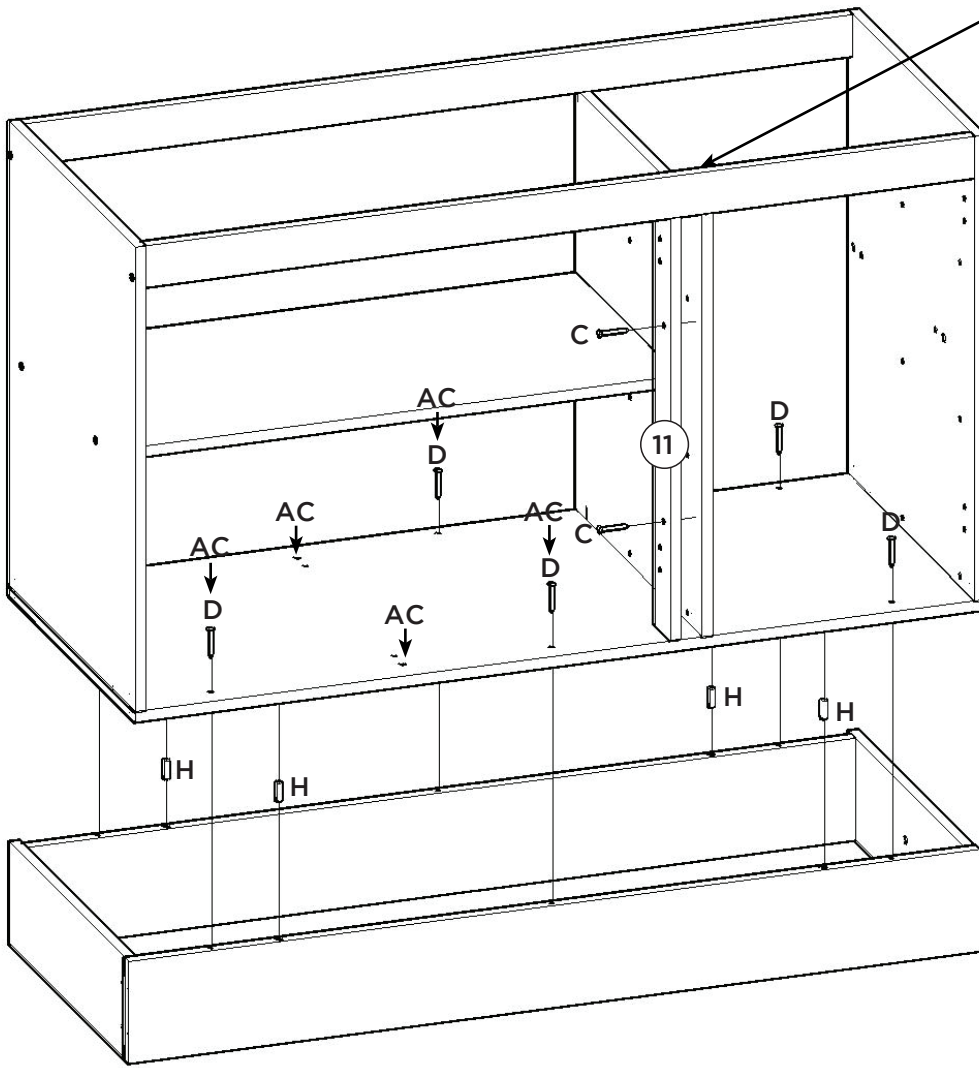

A pilastra da porta (11) deve estar alinhada com a divisão (06).

El pilar de la puerta (11) debe estar alineada con la división (06).

The door pillar (11) must be aligned with the partition (06).

4º

Esse tampo é opcional e é vendido separadamente (C905-114).

Esta vez es opcional y se vende por separado (C905-114).

This top is optional and is sold separately (C905-114).

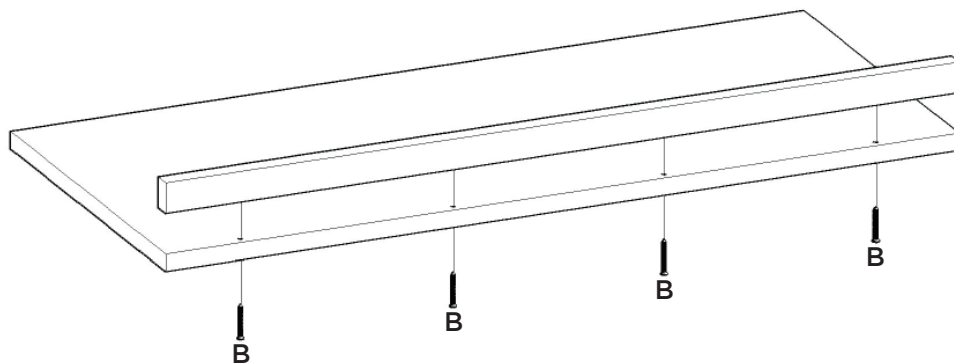



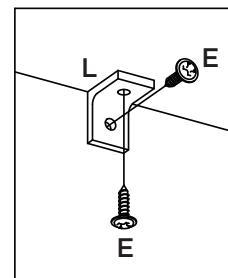
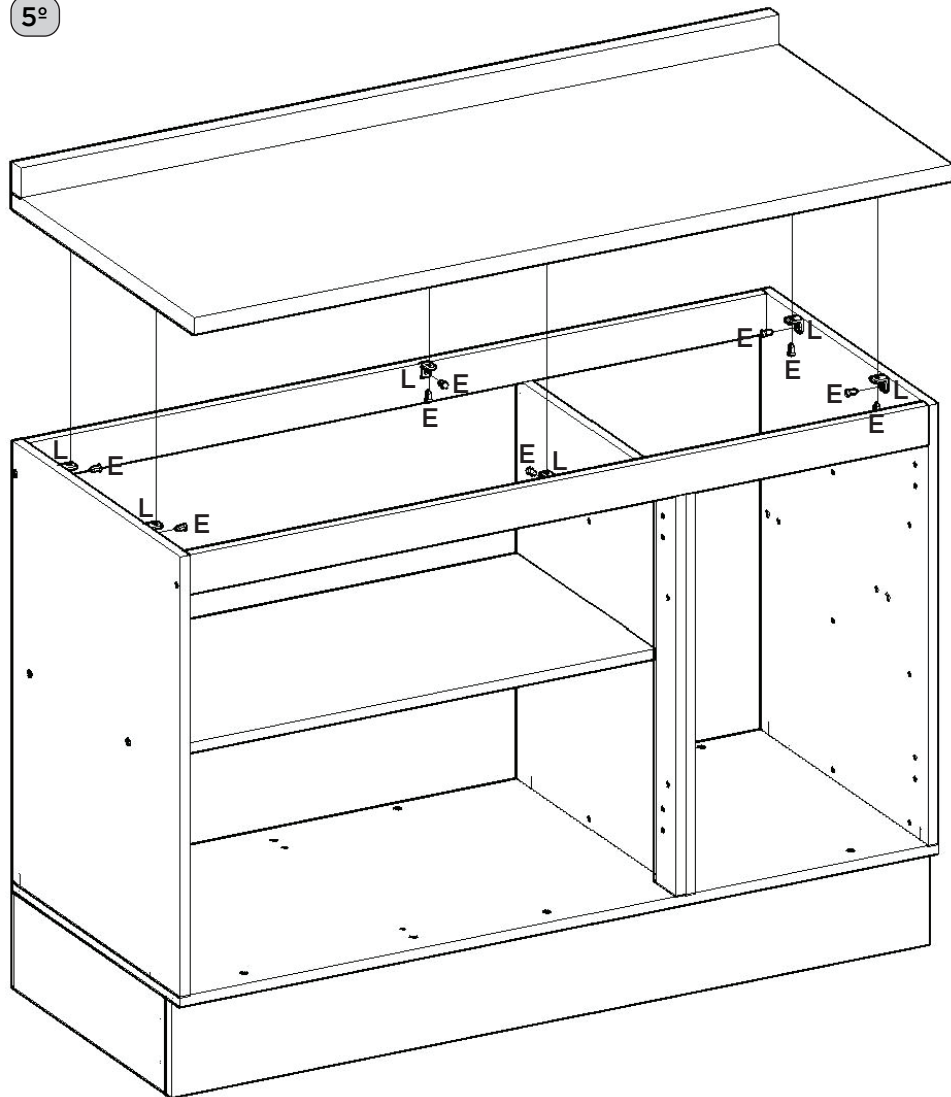

Caso o móvel seja montado com a opção do tampo, fixar o mesmo com 06 cantoneiras (L) e os parafusos 3,5x14mm (E).

Si se monta el auricular con la opción de la cubierta, fijarlo con Los ángulos 06 (L) y 3,5 x14mm tornillos (E).

If the furniture is to be installed with the top cover option, fix it with 06 (L) and 3.5x14mm screws (E).

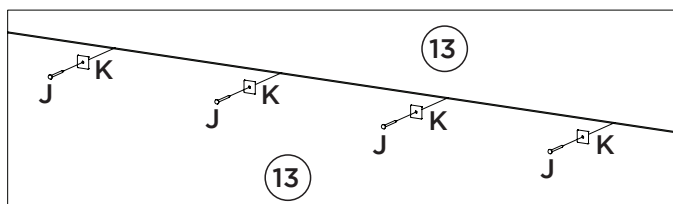
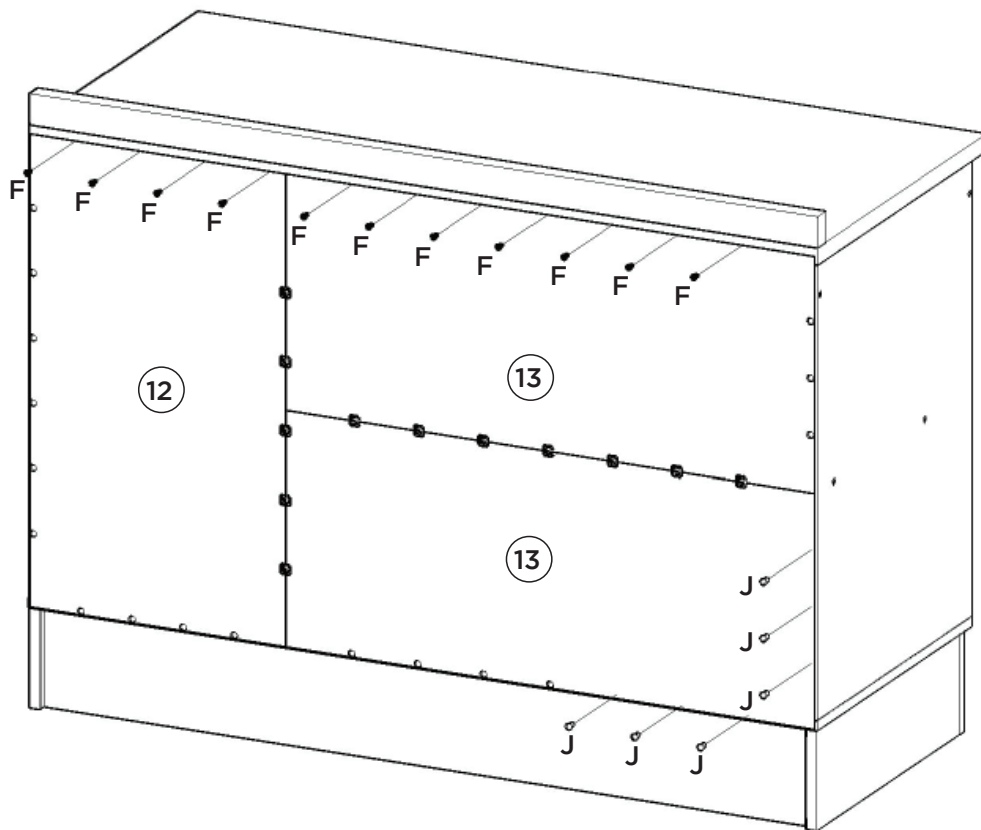
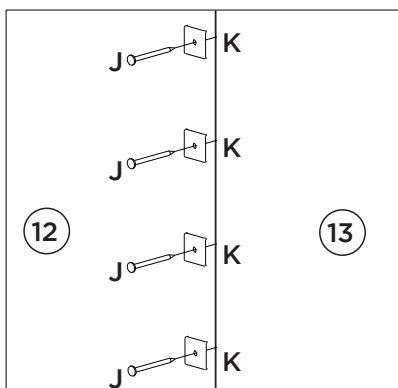

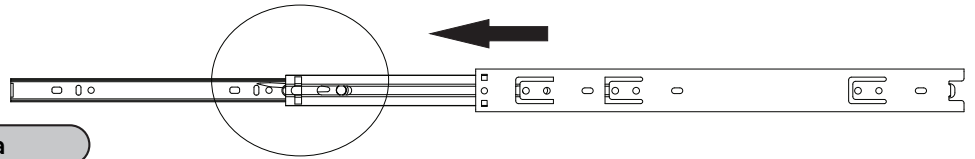
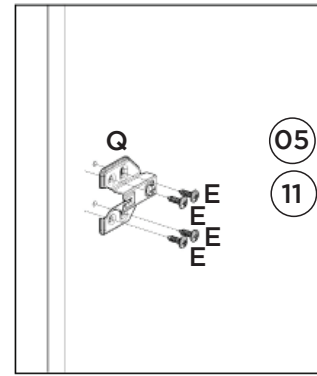
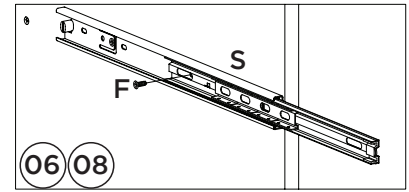
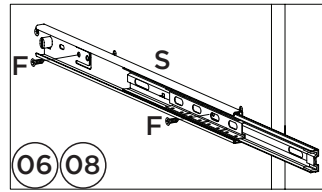
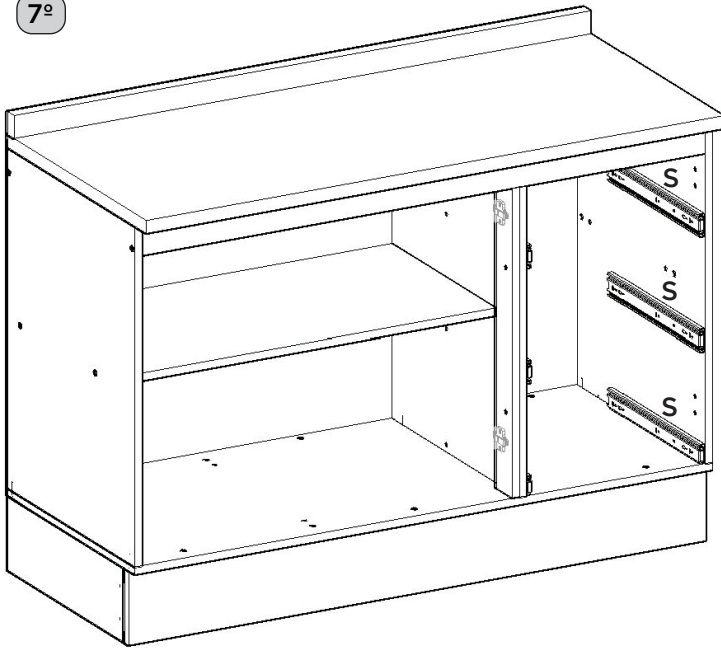

Vídeo: Dicas para fixar a Corrediça

Video: Consejos para arreglar la diapositiva

Video: Tips for Fixing the Slide

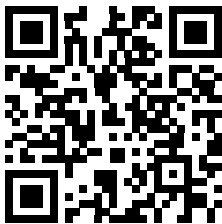

Para a desmontagem da corrediça siga a instrução ao lado.

Para el desmontaje seguimiento de diapositivas la instrucción siguiente a.

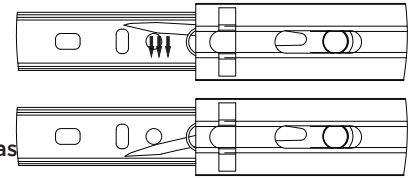

Fixar as corrediças nessas furações  
Fijar las diapositivas de estos agujeros

Opção Suspensa

Opción suspendida

Suspended Option

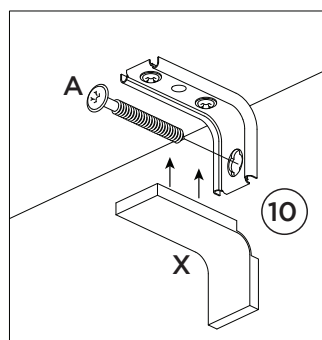
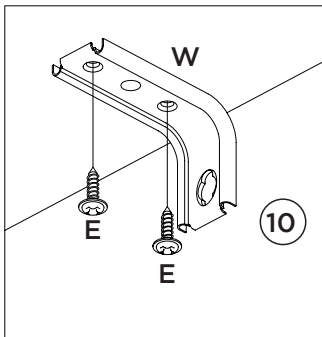

Parede  
pared  
Wall

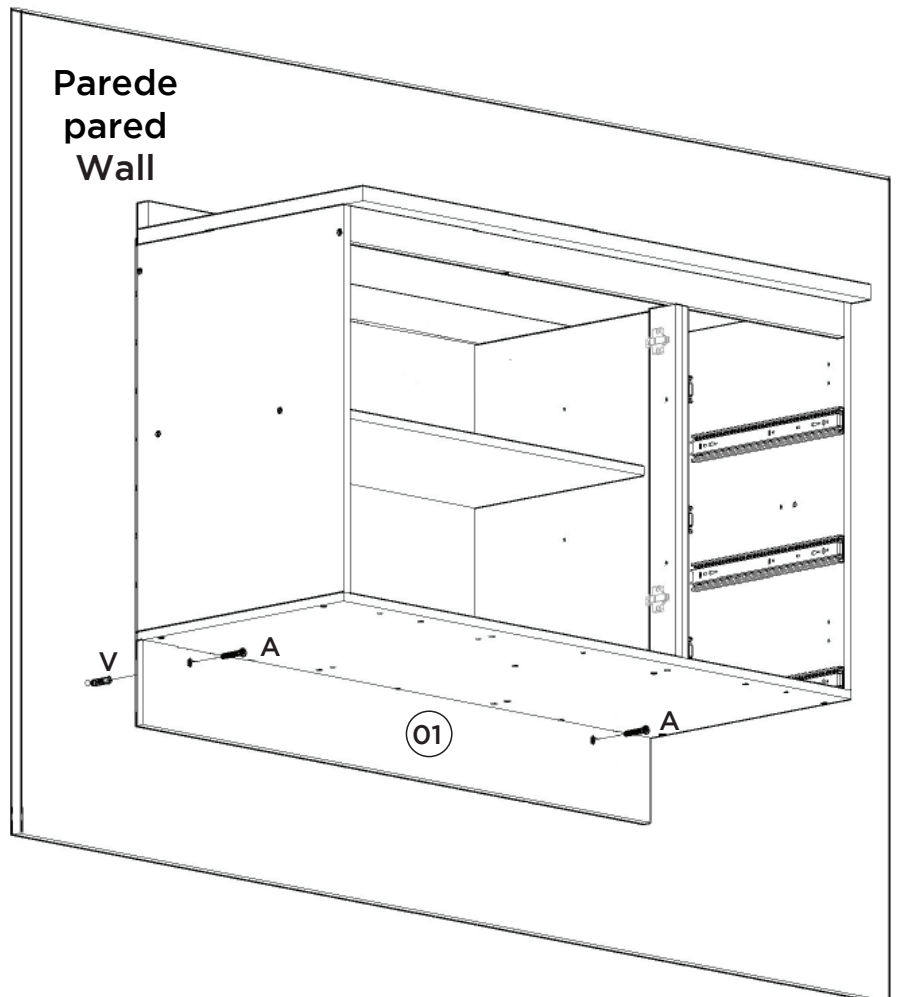

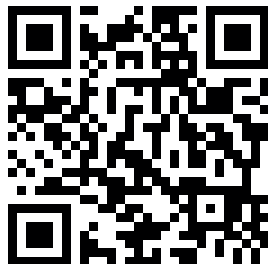
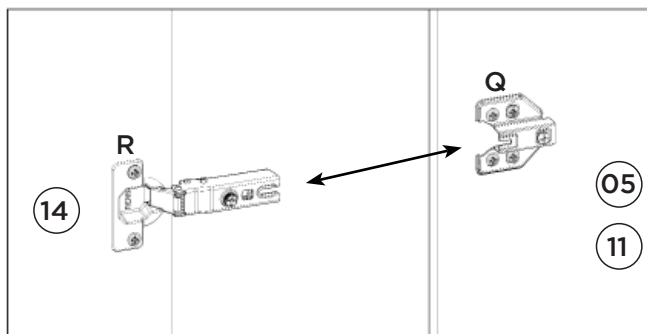
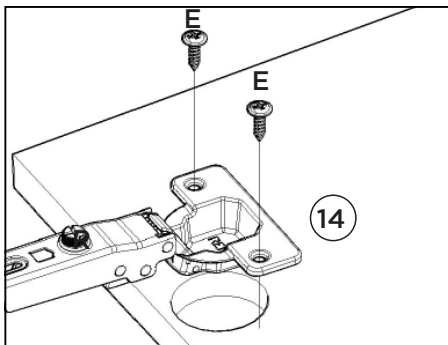

Vídeo: Instalar e regular Dobradiças

Video: Instale y ajuste las bisagras

Video: Install and adjust hinges

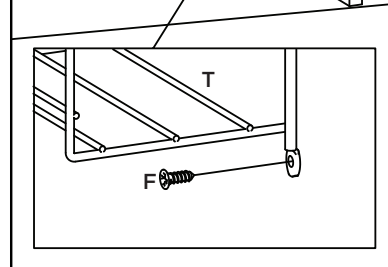
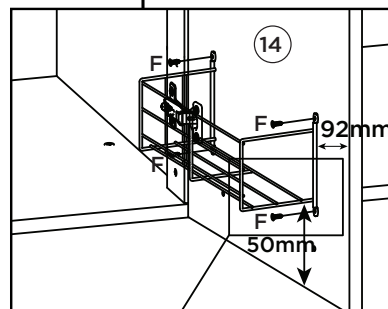
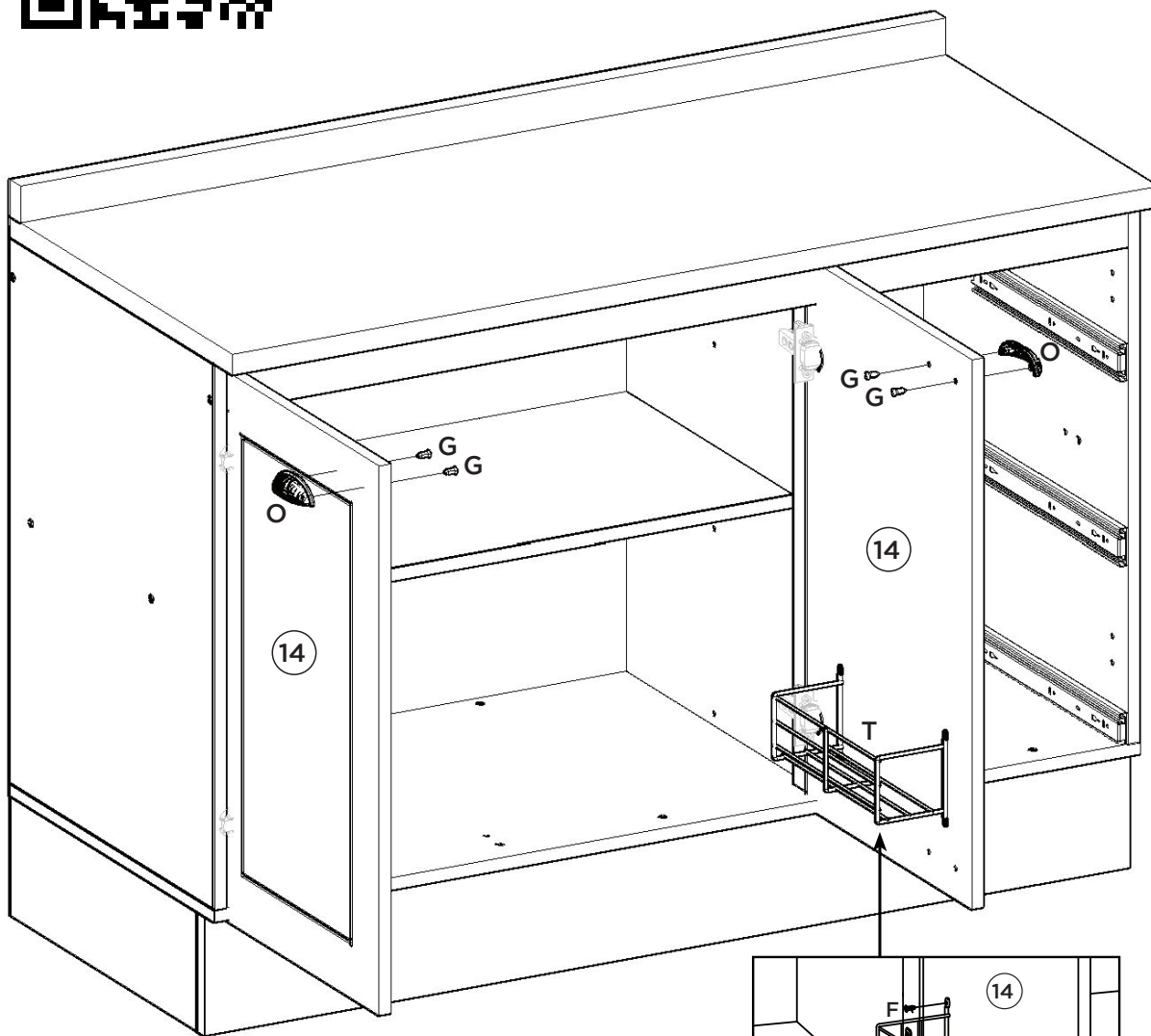



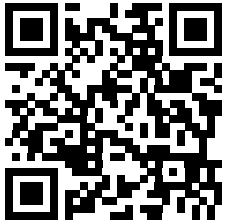
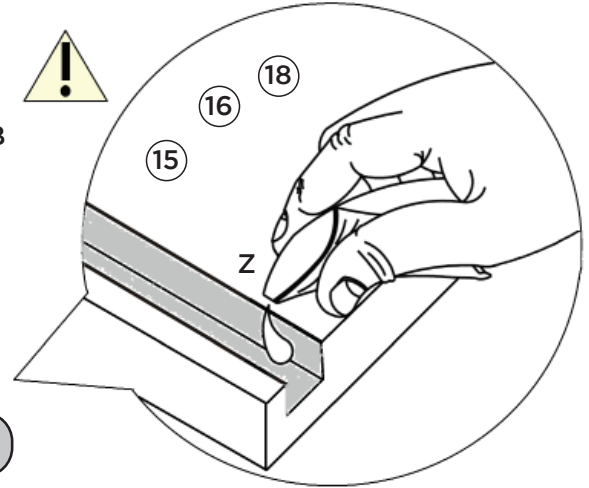
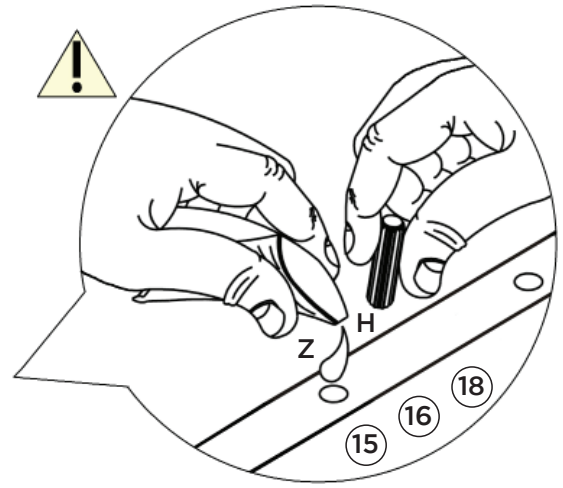
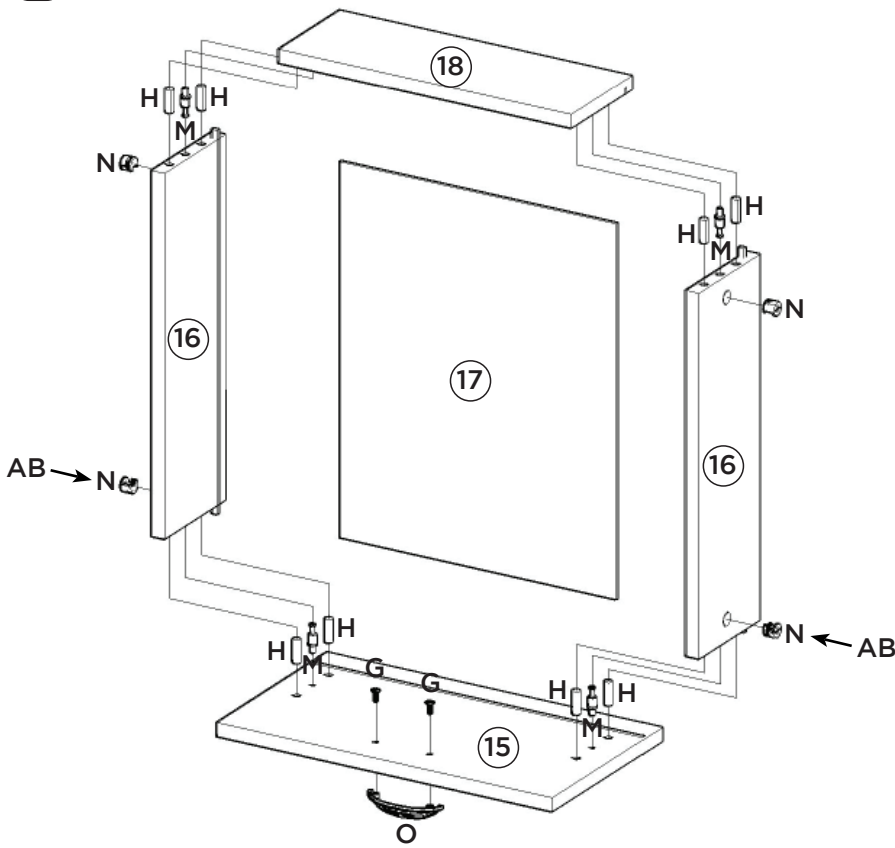

Vídeo: Dicas para fixar o Minifix

Video: Consejos para arreglar Minifix

Video: Tips for Fixing Minifix

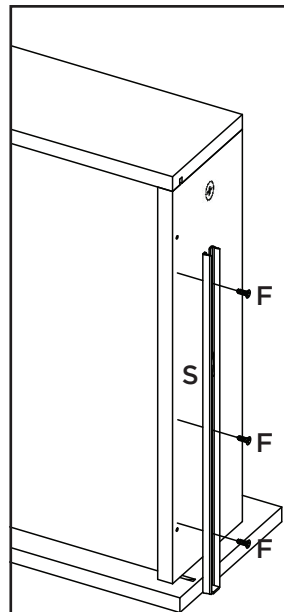
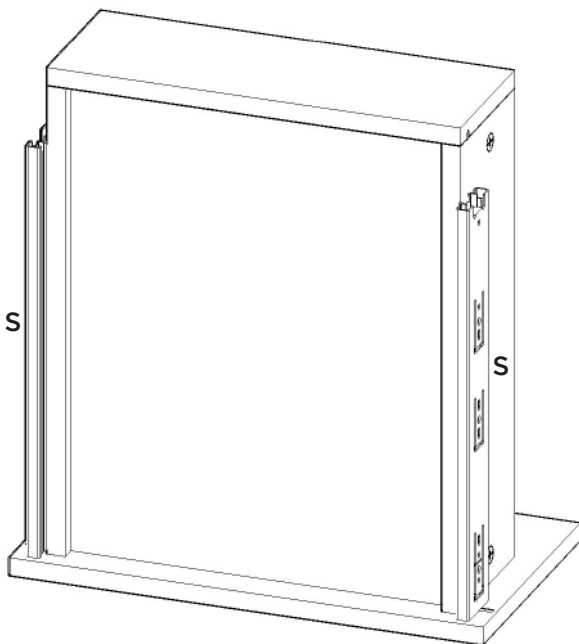

A corredeira (S) deverá ser alinhada com a parte de baixo do lado de gaveta (16).











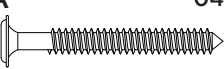



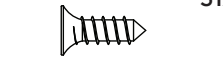



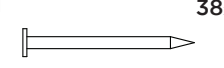



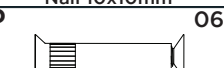

La carcasa (S) será alineada con la parte de por el lado del cajón (16).

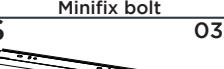
The slide (S) should be aligned with the underside of the drawer side (16).

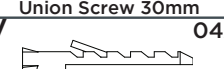
## Lista de Peças | Lista de piezas | List of parts

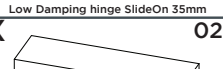
Item	Caixa Caja Box	Qtd Ctd Qty	Descrição   Descripción   Description	Medidas (mm)   Dimensions (mm)   Size (measurements) (mm)
01	1/1	01	Rodapé Frontal   Frente pie de página   Front Footer	1200x145x15
02	1/1	02	Rodapé Lateral   Pie de página Side   Side Footer	450x145x15
03	1/1	01	Rodapé Traseiro   Pie de página trasera   Rear Footer	1168x145x15
04	1/1	01	Base   Base   Base	1200x490x15
05	1/1	01	Lateral esquerda   Lateral izquierda   Left side	660x490x15
06	1/1	01	Divisão   División   Division	600x490x15
07	1/1	01	Prateleira   Estante   Shelf	784x400x15
08	1/1	01	Lateral direita   Lateral derecha   Right side	660x490x15
09	1/1	01	Travessa frontal   Travesaño frontal   Front crossbar	1169x60x15
10	1/1	01	Travessa traseira   Travesaño trasero   Rear bumper	1169x60x15
11	1/1	01	Pilastra da Porta   Pilastra Puerta   Pilaster door	599x60x15
12	1/1	01	Fundo Lateral   Fondo Lateral   Lateral Background	683x389x3
13	1/1	02	Fundo   Fondo   Bottom	803x341x3
14	1/1	02	Porta   Puerta   Door	665x396x15
15	1/1	03	Frente de gaveta   Frente de cajón   Front of drawer	396x220x15
16	1/1	06	Lado de Gaveta   Lado del cajón   Drawer Side	400x122x15
17	1/1	03	Fundo de gaveta   Fondo de cajón   Bottom of drawer	411x326x3
18	1/1	03	Ripa de trás   Malla detrás   Rear lath	345x122x15

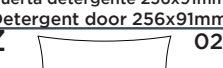
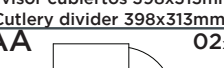
## Ferragens | Herrajes | Hardware

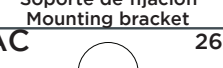
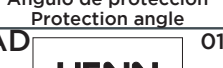
<b>A</b>  Parafuso 5,0x50mm FLA. Tornillo 5,0x50mm FLA. Screw 5,0x50mm FLA.	<b>B</b>  Parafuso 4,5x50mm CHT. Tornillo 4,5x50mm CHT. Screw 4,5x50mm CHT.	<b>C</b>  Parafuso 4,0x25mm CHT. Tornillo 4,0x25mm CHT. Screw 4,0x25mm CHT.	<b>D</b>  Parafuso 3,5x40mm CHT. Tornillo 3,5x40mm CHT. Screw 3,5x40mm CHT.	<b>E</b>  Parafuso 3,5x14mm FLA. Tornillo 3,5x14mm FLA. Screw 3,5x14mm FLA.	<b>F</b>  Parafuso 3,5x12mm CHT. Tornillo 3,5x12mm CHT. Screw 3,5x12mm CHT.
<b>G</b>  Parafuso M4x20mm CHT. ZB Tornillo M4x20mm CHT. ZB Screw M4x20mm CHT. ZB	<b>H</b>  Cavilha 8x25mm Cinta 8x25mm Dowel 8x25mm	<b>I</b>  Prego 12x12mm Anelado Clavo 12x12mm Anillado Ringed Nails 12x12mm	<b>J</b>  Prego 10x10mm Clavo 10x10mm Nail 10x10mm	<b>K</b>  Fixador de fundos Fijador de fondos Bottom xer	<b>L</b>  Cantoneira plástica Cantenera plástica Plastic angle brackets
<b>M</b>  Parafuso minifix Tornillo minifix Minifix bolt	<b>N</b>  Tambor minifix Tambor minifix Minifix drum	<b>O</b>  Puxador Concha Tirador Concha Shell Handle	<b>P</b>  Parafuso União 30mm Tornillo Unión 30mm Union Screw 30mm	<b>Q</b>  Calço Removível Calzado extraíble Removable Shim	<b>R</b>  Dobradiça SlideOn Baixa Amortecimento 35mm Bisagra SlideOn Baja Amortiguación 35mm Low Damping hinge SlideOn 35mm
<b>S</b>  Corrediça telescópica Diapositivas telescópicas Telescopic slides	<b>T</b>  Porta detergente 256x91mm Puerta detergente 256x91mm Detergent door 256x91mm	<b>U</b>  Divisor talheres 398x313mm Divisor cubiertos 398x313mm Cutlery divider 398x313mm	<b>V</b>  Buchta plástica 8mm Buchta de plástico 8mm 8mm plastic bushing	<b>W</b>  Suporte de fixação Soporte de fijación Mounting bracket	<b>X</b>  Proteção para cantoneira Ángulo de protección Protection angle
<b>Y</b>  Sapata "L" 16x20mm Zapata "L" 16x20mm "L" shoe 16x20mm	<b>Z</b>  Sachê de cola Bolsa de pegamento Glue bag	<b>AA</b>  Giz de correção Tiza de corrección Chalk of correction	<b>AB</b>  Adesivo tapa parafuso 17mm Adhesivo tapón de tornillo 17mm Bolt cover adhesive 17mm	<b>AC</b>  Adesivo tapa parafuso 10mm Adhesivo tapón de tornillo 10mm Bolt cover adhesive 10mm	<b>AD</b>  Etiqueta resinada Henn Etiqueta resinada Henn Henn resin label



O parafuso (P) deve ser usada somente quando este módulo for acoplado a outro módulo componível Henn.



El tornillo (P) se debe utilizar sólo cuando el módulo está conectado a otro módulo componible Henn.



The screw (P) should be used only when this module is attached to another Henn modular module.

## RECOMENDAÇÃO

Para fixar o móvel na parede usar o suporte de fixação (W), o parafuso 3,5x14mm FLA (E), a Bucha 8mm (V) e o parafuso 5,0x50mm FLA (A).

## RECOMENDACIÓN

Para conectar el móvil a la pared con el soporte (W), tornillo 3,5 x14mm FLA (E), el casquillo de 8 mm (V) y el 5,0 x50mm tornillo FLA (A).

## RECOMMENDATION

To fix the furniture to the wall use the mounting bracket (W), the 3.5x14mm FLA (E) screw, the 8mm bushing (V) and the 5.0x50mm FLA screw (A).

# HENN

Ind. e Com. de Móveis Henn  
Mondai - SC - Brasil

+55 49 3674.3500

@moveishenn  
www.henn.com.br

## INSTRUÇÕES DE MONTAGEM

INSTRUCCIONES DE MONTAJE  
ASSEMBLY INSTRUCTIONS

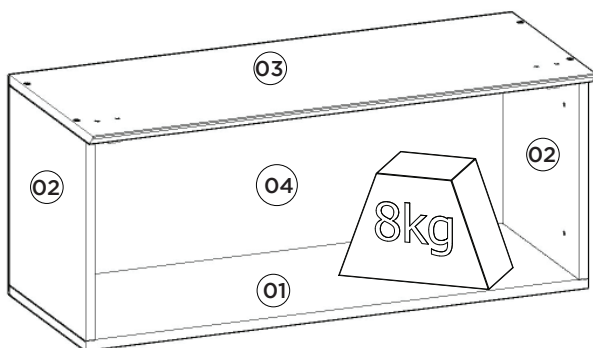
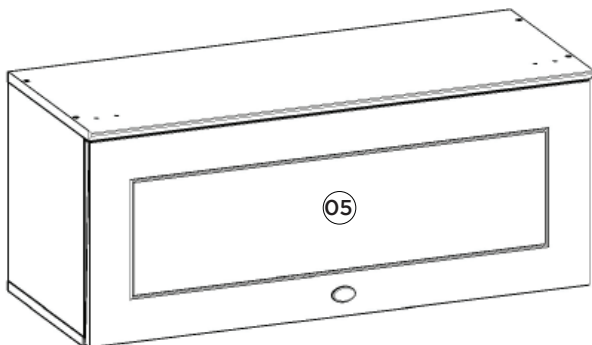

1º

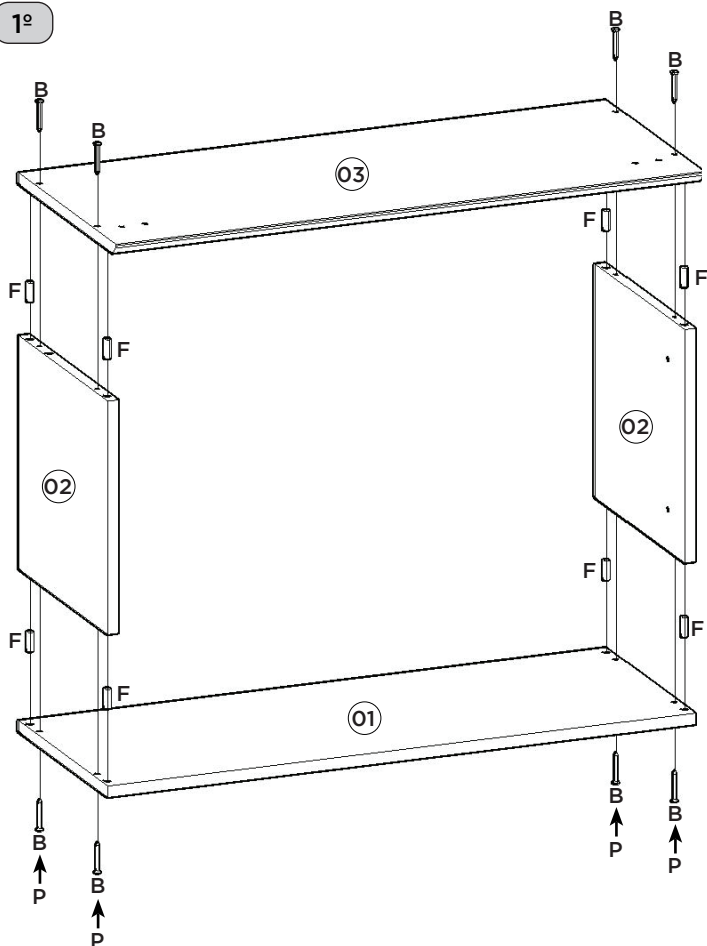

Utilizar o sachê de cola (O)  
em todas as cavilhas (F)  
do produto.

Con el pegamento sobre (O)  
en todos los pernos (F)  
producto.

Use the glue sachet (O) on all  
the pegs (F) of the product.

2º

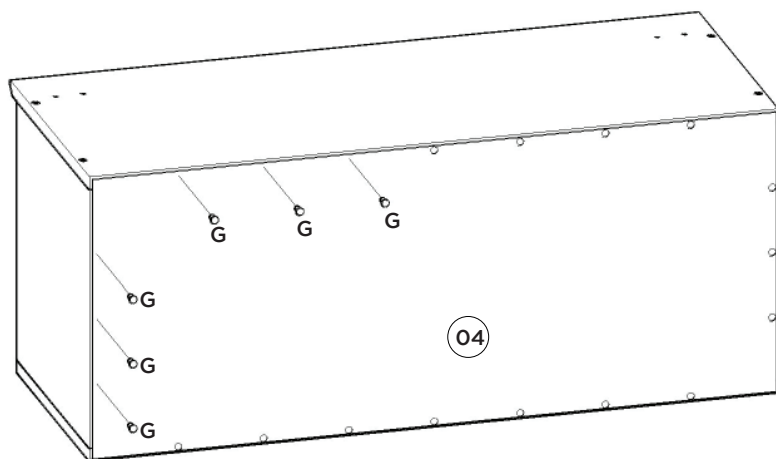

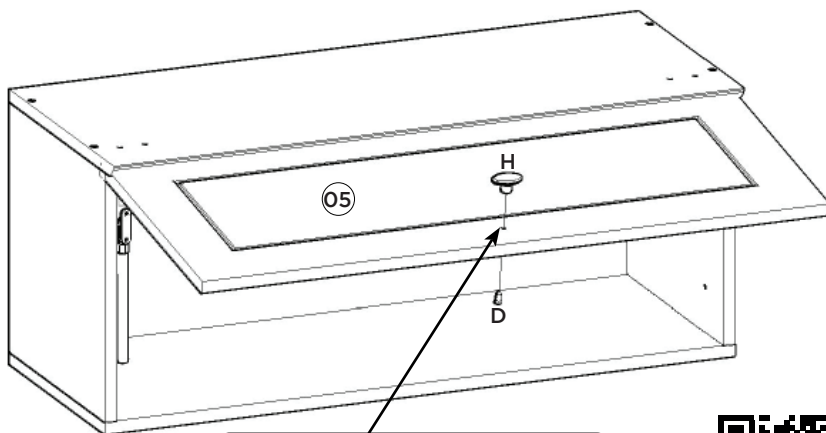

Para colocação do puxador, é necessário fazer a furação passante, com broca de 5mm.

Para colocar el mango, es necesario perforar con un taladro de 5 mm.

For placing the handle, it is necessary to drill through with a 5mm drill.



Video: Instalar e regular Dobradiças

Video: Instale y ajuste las bisagras

Video: Install and adjust hinges

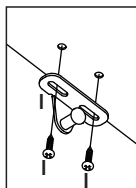
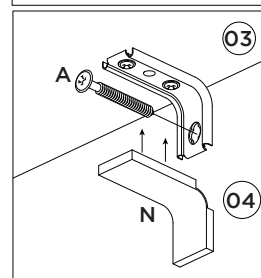
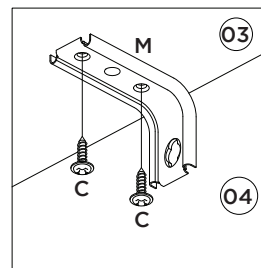
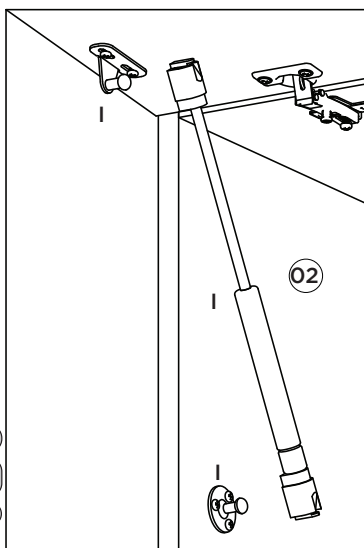
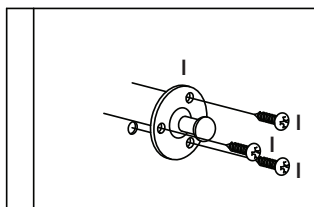
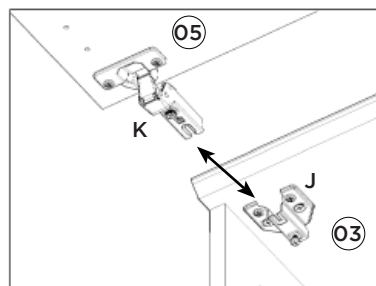
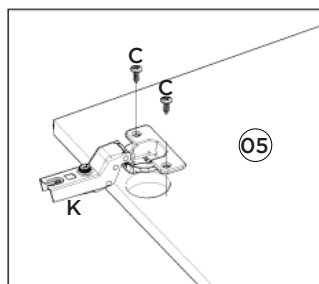
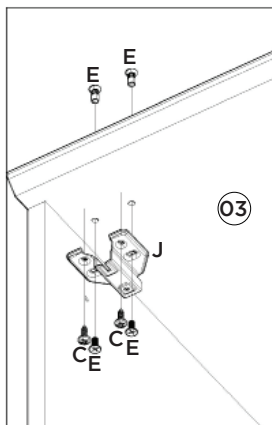

Video: Dicas para instalar o Kit Pistão à Gás

Video: Consejos para instalar el kit de pistón de gas















Video: Tips for installing the Gas Piston Kit

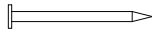

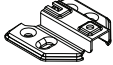
## Lista de Peças | Lista de piezas | List of parts

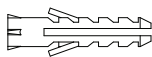
Item	Caixa Caja Box	Qty Ctd Qty	Descrição   Descripción   Description	Medidas (mm)   Dimensions (mm)   Size (measurements) (mm)
01	1/1	01	Base   Base   Base	800x295x15
02	1/1	02	Lateral Direita Esquerda   Lateral Derecha Izquierda   Right Side Left	307x295x15
03	1/1	01	Tampo   Tapa   Top	800x322x15
04	1/1	01	Fundo   Fondo   Bottom	793x331x3
05	1/1	01	Porta Basculante   Puerta Basculante   Basculating Door	796x315x15

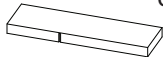
## Ferragens | Herrajes | Hardware

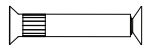
<b>A</b>  Parafuso 5,0x50mm FLA. Tornillo 5,0x50mm FLA. Screw 5,0x50mm FLA.	02x	<b>B</b>  Parafuso 3,5x40mm CHT. Tornillo 3,5x40mm CHT. Screw 3,5x40mm CHT.	08x	<b>C</b>  Parafuso 3,5x14mm FLA. Tornillo 3,5x14mm FLA. Screw 3,5x14mm FLA.	12x	<b>D</b>  Parafuso M4x20mm CHT. ZB Tornillo M4x20mm CHT. ZB Screw M4x20mm CHT. ZB	01x	<b>E</b>  Parafuso União 15mm Tornillo Unión 15mm Union Screw 15mm	04x
<b>F</b>  Cavilha 8x25mm Cinta 8x25mm Dowel 8x25mm	08x	<b>G</b>  Prego 10x10mm Clavo 10x10mm Nail 10x10mm	20x	<b>H</b>  Puxador Pontual PZ14 Oval Tirador Pontual PZ14 Oval PZ14 Oval Point Knob	01x	<b>I</b>  Kit Pistão a Gás 60N Kit Pistón a Gas 60N 60N Gas Piston Kit	01x	<b>J</b>  Calço Removível Calzado extraíble Removable Shim	02x
<b>K</b>  Dobradiza SlideOn Super Alta Amort. 35mm Bisagra Super high amort de Slideon. 35mm Slideon Super High Amort hinge. 35mm	02x	<b>L</b>  Bucha plástica 8mm Bucha de plástico 8mm 8mm plastic bushing	02x	<b>M</b>  Suporte de fixação Soporte de fijación Mounting bracket	02x	<b>N</b>  Proteção para cantoneira Ángulo de protección Protection angle	02x	<b>O</b>  Sachê de cola Bolsa de pegamento Glue bag	01x
<b>P</b>  Adesivo tapa parafuso 10mm Adhesivo tapón de tornillo 10mm Bolt cover adhesive 10mm	08x	<b>Q</b>  Parafuso União 30mm Tornillo Unión 30mm Union Screw 30mm	04x						



O parafuso (Q) deve ser usada somente quando este módulo for acoplado a outro módulo componível Henn.



El tornillo (Q) se debe utilizar sólo cuando el módulo está conectado a otro módulo componible Henn.



The screw (Q) should be used only when this module is attached to another Henn modular module.

## RECOMENDAÇÃO

Para fixar o móvel na parede usar o suporte de fixação (M), o parafuso 3,5x14mm FLA (C), a Bucha 8mm (L) e o parafuso 5,0x50mm FLA (A).

## RECOMENDACIÓN

Para conectar el móvil a la pared con el soporte (M), tornillo 3,5 x14mm FLA (C), el casquillo de 8 mm (L) y el 5,0 x50mm tornillo FLA (A).

## RECOMMENDATION

To fix the furniture to the wall use the fixing bracket (M), the 3.5x14mm FLA (C) screw, the 8mm bushing (L) and the 5.0x50mm FLA screw (A).