

## 331 - CAMARIM ESCRIVANINHA DE CANTO GLOW

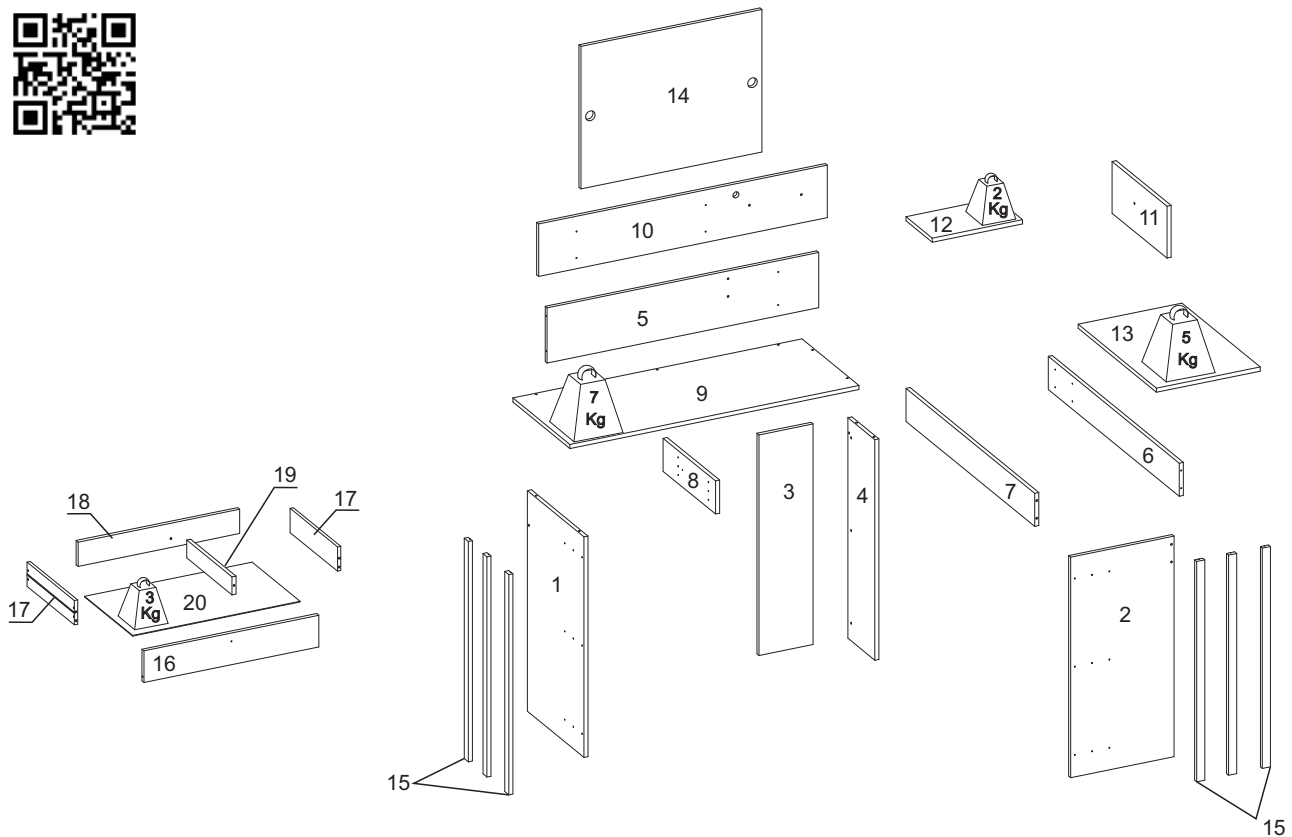

### LISTA DE PEÇAS / Pieces List / Lista de Piezas

SEQ.	REF.	DESCRIÇÃO	DESCRIPTION	DESCRIPCIÓN	MAT.PRIMA	COMP.	LARG.	ESP.	QTD.
1	333054	Lateral esquerda	Left side panel	Panel lateral izquierdo	MDP	800	420	15	1
2	333055	Lateral direita	Right side panel	Panel lateral derecho	MDP	800	382	15	1
3	333056	Pé traseiro	Rear leg	Pata trasera	MDP	800	200	15	1
4	333057	Pé lateral	Side leg	Pata lateral	MDP	800	200	15	1
5	333058	Trava traseira maior	Larger rear latch	Pestillo trasero más grande	MDP	1005	200	15	1
6	333059	Vista traseira lateral	Rear side view	Vista lateral trasera	MDP	969	120	15	1
7	333060	Vista frontal lateral	Front side view	Vista lateral delantera	MDP	952	120	15	1
8	333061	Divisória gaveta direita	Right drawer divider	Divisor de cajón derecho	MDP	387	120	15	1
9	333062	Tampo maior	Larger top panel	Panel superior más grande	MDP	1070	422	15	1
10	333063	Painel traseiro superior	Upper rear panel	Panel trasero superior	MDP	1068	190	15	1
11	333064	Painel lateral superior	Upper side panel	Panel lateral superior	MDP	406	188	15	1
12	333065	Prateleira	Shelf	Estante	MDP	334	195	15	1
13	333066	Tampo menor	Smaller top panel	Panel superior más pequeño	MDP	580	384	15	1
14	333067	Painel espelho	Mirror panel	Panel de espejo	MDP	670	517	15	1
15	333068	Ripado	Slatted panel	Panel de listones	MDP	799	30	15	6
16	333069	Frente de gaveta	Drawer front panel	Panel frontal del cajón	MDP	647	115	15	1
17	333070	Lateral de gaveta	Drawer side panel	Panel lateral del cajón	MDP	350	88	12	2
18	333071	Contra fundo	Back panel	Panel trasero	MDP	598	88	15	1
19	333072	Divisor gaveta	Drawer divider	Divisor de cajón	MDP	335	65	15	1
20	333073	Fundo da gaveta	Drawer bottom	Parte inferior del cajón	HDF	620	355	3	1

## INSTRUÇÃO MONTAGEM PRODUTO

Intructions to Assembly / Instrucciones de montaje

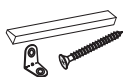

Separe as peças e acessórios de maneira organizada  
Separate parts and accessories in way organized  
Separe las piezas y accesorios de manera organizada



Forrar o chão com o papelão das embalagens.  
Cover the floor with the cardboard  
Cubra el suelo con la embalaje de cartón



É necessário 01 pessoa para montar o produto  
01 people are required to assemble the product  
Se requieren 01 persona para ensamblar el producto

O produto deve ser a montado por um profissional qualificado  
The product must be assembly by a professional  
El producto debe ser ensamblado por un profesional calificado

Ferramentas necessárias  
(não fornecidas)

Not include tools / No herramientas



## CUIDADO PARA CONSERVAÇÃO E LIMPEZA DO MÓVEL

Care to conservation and clean / Cuidados de limpieza

Peso máximo de carga informado refere-se a objetos distribuído de maneira uniforme sobre toda área de contato da peça



The maximum load weight informed refers to objects distributed evenly over the entire contact area of the part  
Conjunto de carga máxima de peso se refere a objetos distribuídos uniformemente sobre toda el área de contacto de la pieza de trabajo.



Não molhar o móvel e não expor em lugar úmido  
Do not wet the mobile and do not expose in a wet place  
No moje el producto y no exponer en un lugar húmedo



Não expor o móvel próximo de fontes de calor.  
Do not expose the mobile near heat sources  
no exponga cercano de fuentes de calor



Não usar produtos abrasivos.  
Do not use abrasive products.  
No utilice productos abrasivos.



Limpe com flanela limpa e seca.  
Clean with dry cloth  
Limpieza con un paño limpio y seco



Para limpar os carimbos das peças utilize uma borracha escolar ( item não fornecido)  
Para clean the stamps on the pieces use a school eraser ( item not provided)  
Para limpiar los sellos de las piezas utilice un borrador escolar ( artículo não incluido )

## LISTA DE ACESSÓRIOS E FERRAGENS / ACCESSORIES AND HARDWARE / ACCESORIOS Y HARDWARE



A- 700137-Parafuso 4,5x45 (18x)  
screw / tornillo



B- 700124Parafuso 3,5x25 (37x)  
screw / tornillo

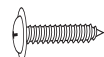

C- 700127-Parafuso 4,0x12 (68x)  
screw / tornillo



D- 700121-Parafuso 3,5x12 (30x)  
screw / tornillo



E- 700157-Prego (13x)  
nail / clavo



F- 700542-Cavilha 6x30 (11x)  
peg / cerrojo

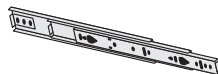

G- 700113-Corrediça (01x)  
runners / corredera



H- 700448-Sapata 'L' (06x)  
shoe / zapata



I- 701157-Suporte triangular (03x)  
Triangular support / Soporte triangular



J- 702777-Puxador (01x)  
Puller / Arrancador



K- 700546-Chapa de união 4 furos (02X)  
Union plate/Placa de unión



L - 700539-Cantoneira metálica 4 furos (12x)  
corner / esquina

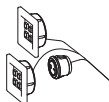

M- 700628-kit luminaria(01x)  
light kit / kit de luz



N- 7001271 - Espelho (01x)  
Mirror / Espejo



O- 700675-Kit fixação espelho (01x)  
Mirror mounting kit  
Kit de fijación del espejo

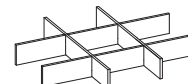

P- 703086-Divisor joias(01x)  
jewelry divider / divisor de joyas



Q- 700516-Sache cola 20g (01x)  
Glue / Goma



R- 700419-Tapa furo minifix (20x)  
cover / tapa

01° PASSO - Fixar os acessórios H na peça 1, encaixar o acessório F na peça 1, fixar as peças 15 na peça 1

01° STEP - Fix accessories H to piece 1, fit accessory F to piece 1, Fix pieces 15 to piece 1

01° PASO - Fijar los accesorios H a la pieza 1, ajuste el accesorio F a la pieza 1, Fijar las piezas 15 a la pieza 1



OBS; Fixar o parafuso B no canal da peça 15  
NOTE; Fix screw B in the channel of part 15  
NOTA; Fijar el tornillo B en el canal de la pieza 15

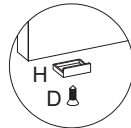
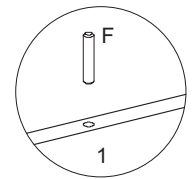
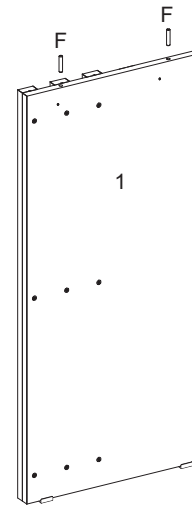
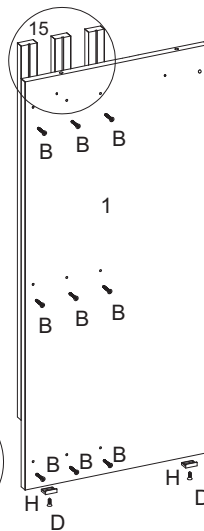
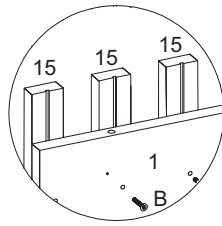

02° PASSO - Fixar os acessórios H na peça 2, e fixar as peças 15 na peça 2

02° STEP - Fix accessories H to piece 2, and Fix pieces 15 to piece 2

02° PASO - Fijar los accesorios H a la pieza 2, Fijar las piezas 15 a la pieza 2

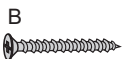

OBS; Fixar o parafuso B no canal da peça 15  
NOTE; Fix screw B in the channel of part 15  
NOTA; Fijar el tornillo B en el canal de la pieza 15

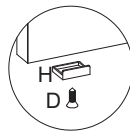
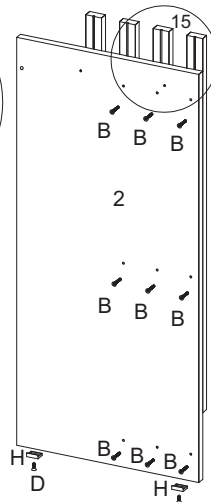
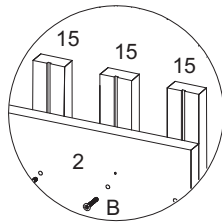

03° PASSO - Fazer a separação das corredeiras

03° STEP - Separate the slides

03° PASO - Separar las diapositivas

G

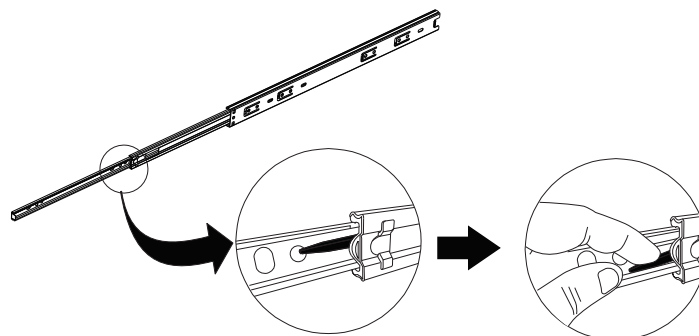

Abaixe a alça preta e retire a peça conforme abaixo.  
Push the black pin down to remove the D1 part.  
Empujar para abajo la pieza negra para retirar la parte D1.

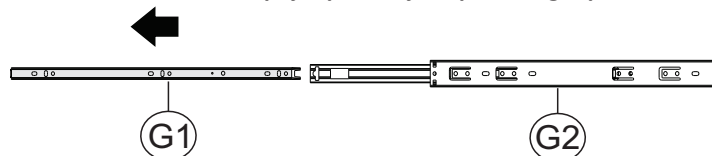

04° PASSO - Fixar os acessórios D+G2 na peça 1

04° STEP - Fix the D+G2 accessories to part 1.

04° PASO - Fijar los accesorios D+G2 a la pieza 1.

D



G2

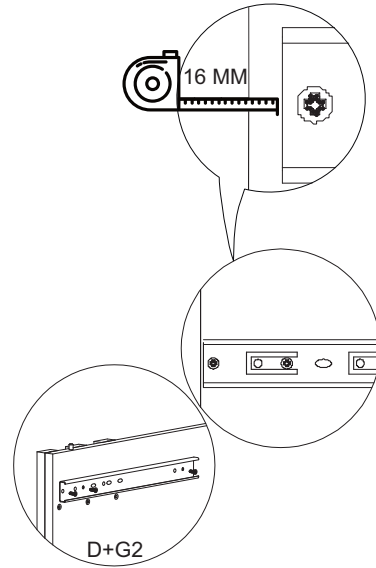
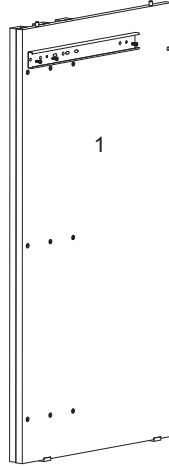

05° PASSO - Fixar acessórios D+G2 na peça 8

05° STEP - Fix D+G2 accessories to part 8.

05° PASO - Fijar los accesorios D+G2 en la pieza 8.

D



G2

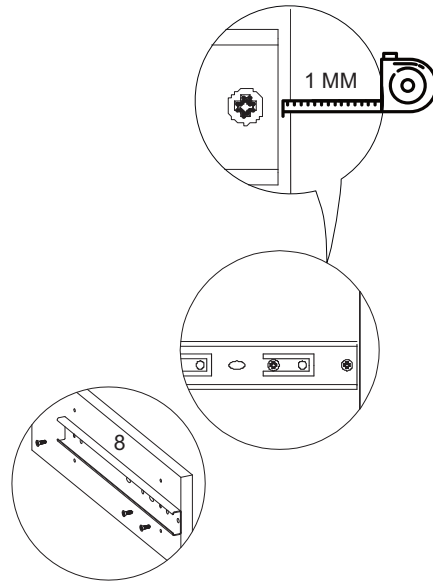
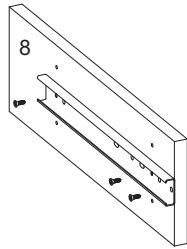

06° PASSO - Fixar peça 3 na peça 4

06° STEP - Fix part 3 to part 4.

06° PASO - Fijar la parte 3 a la parte 4.

A



D



F



H

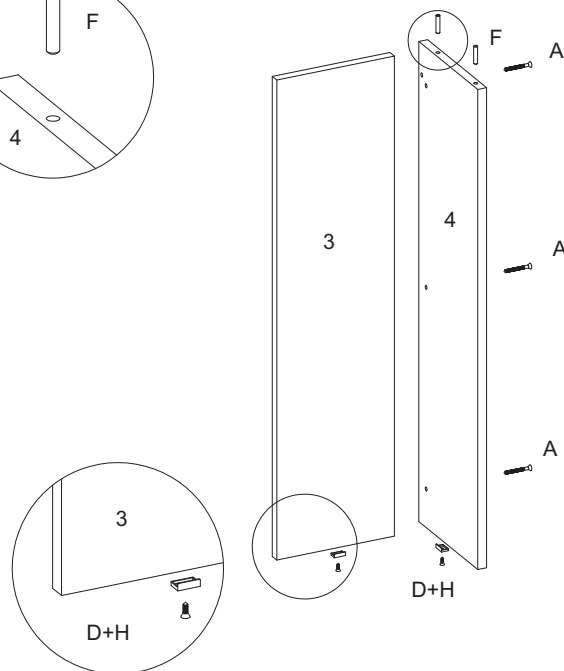
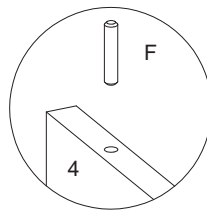

D+H

07° PASSO - Fixar a peça 5 nas peças 1,3 e 4

07° STEP - Fix part 5 to parts 1, 3, and 4.

07° PASO - Fijar la parte 5 a las partes 1, 3 y 4.

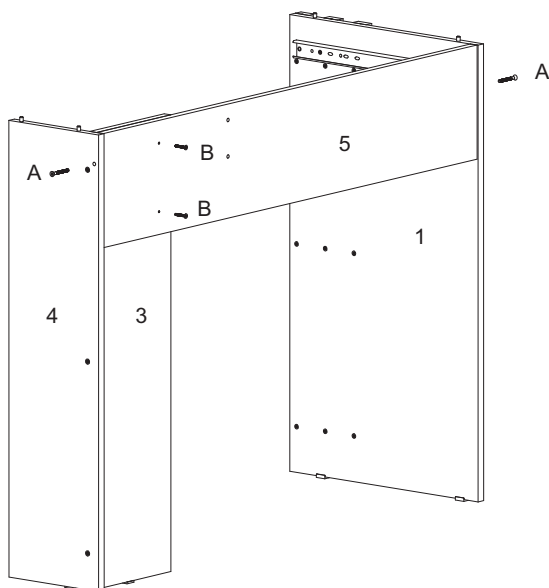
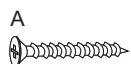

08° PASSO - Fixar peças 6 e 7 nas peças 2,4 e 5

08° STEP - Fix parts 6 and 7 to parts 2, 4, and 5.

08° PASO - Fijar las piezas 6 y 7 a las piezas 2, 4 y 5.

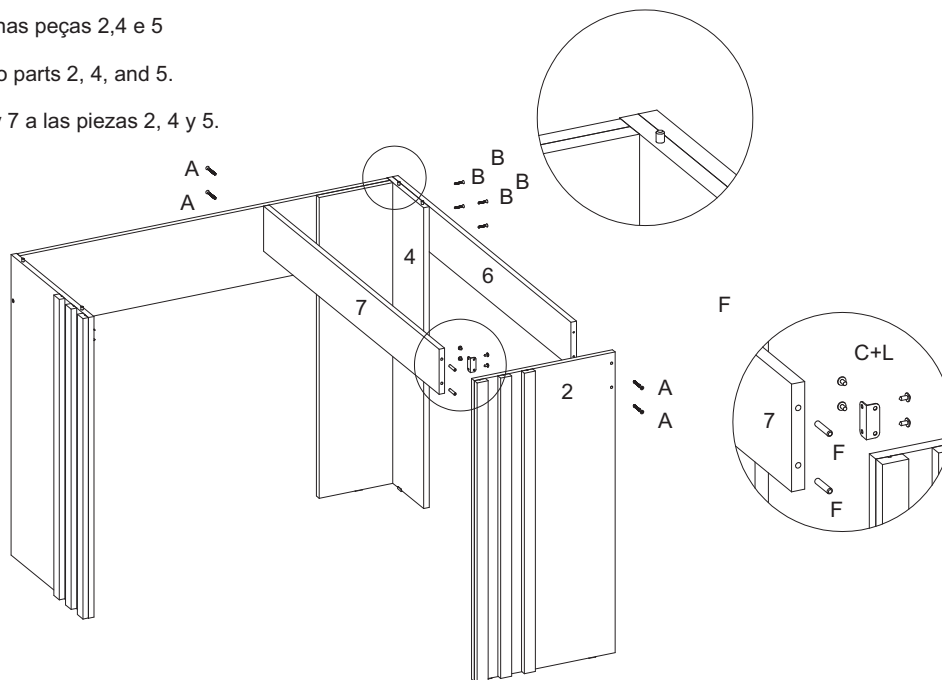

09° PASSO - Fixar peça 8 na peça 7

09° STEP - Fix part 8 to part 7.

09° PASO - Fijar la parte 8 a la parte 7.

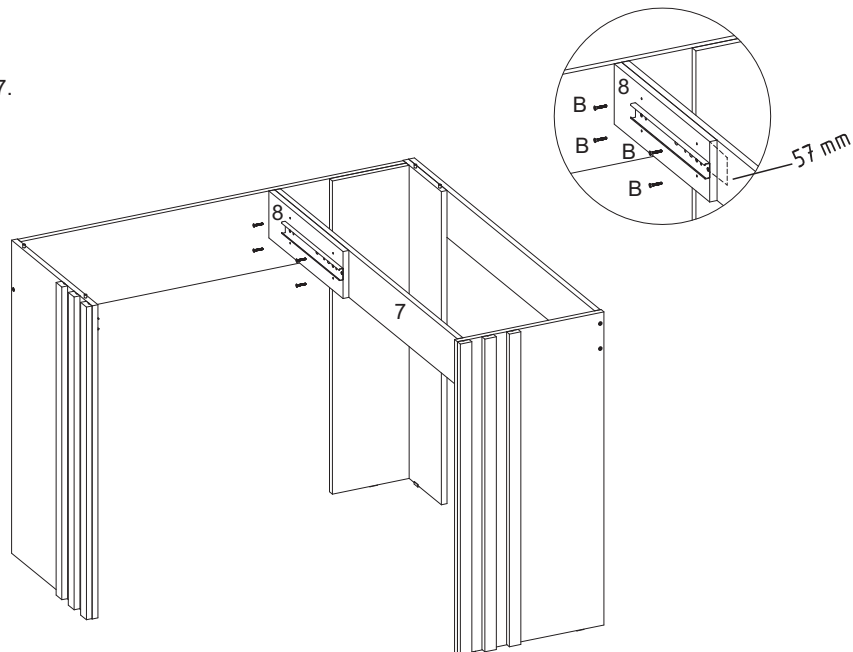

10º PASSO - Fixar os acessórios C+L nas peças 1,2,3,4,5,6 e 7

10º STEP - Fix the C+L accessories to parts 1, 2, 3, 4, 5, 6 and 7.

10º PASO - Fijar los accesorios C+L a las piezas 1, 2, 3, 4, 5, 6 y 7.

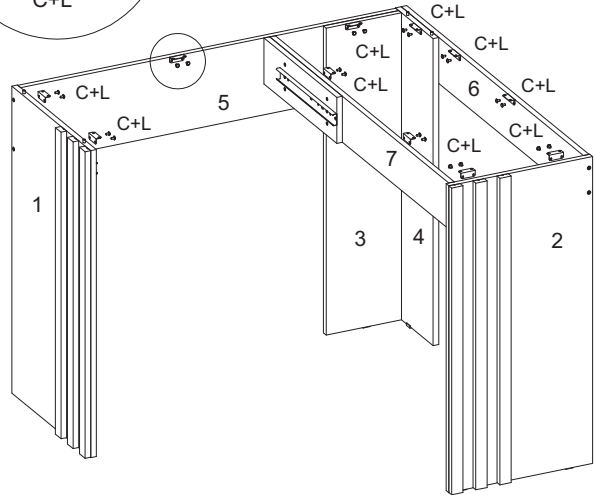
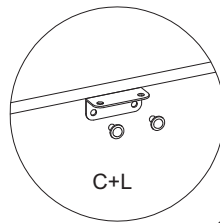

11º PASSO - Fixar peça 9 nas peças 10 e 11

11º STEP - Fix part 9 to parts 10 and 11.

11º PASO - Fijar la parte 9 a las partes 10 y 11.

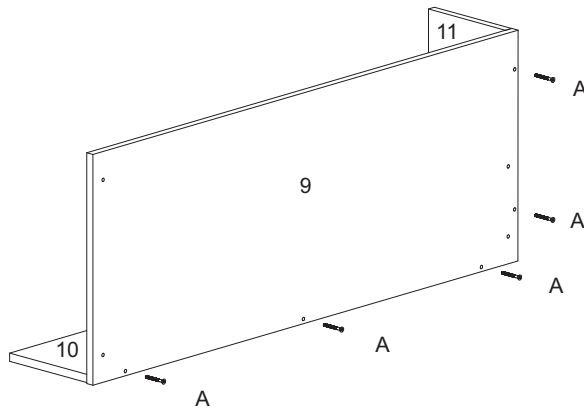

12º PASSO - Fixar peça 9 nas peças 1 e 4

12º STEP - Fix part 9 to parts 1 and 4.

12º PASO - Fijar la parte 9 a las partes 1 y 4.

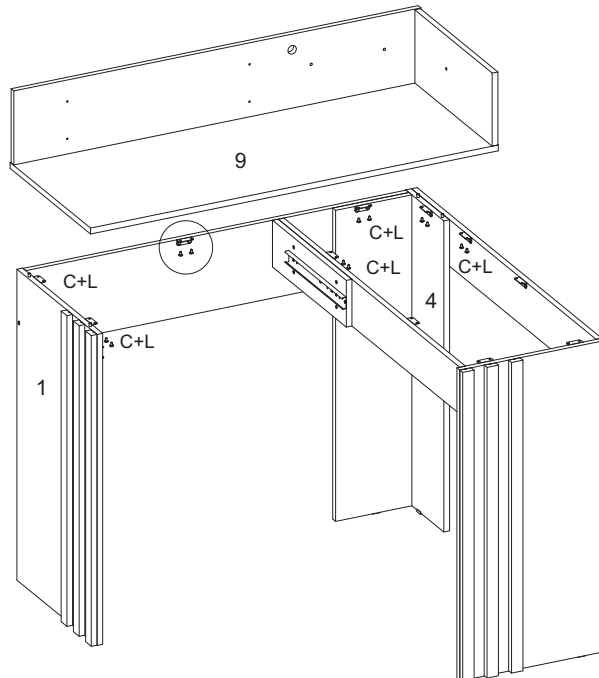
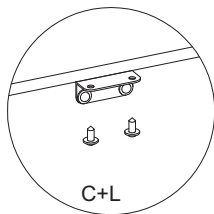

13° PASSO - Fixar peça 12 nas peças 10 e 11

13° STEP - Fix part 12 to parts 10 and 11.

13° PASO - Fijar la parte 12 a las partes 10 y 11.

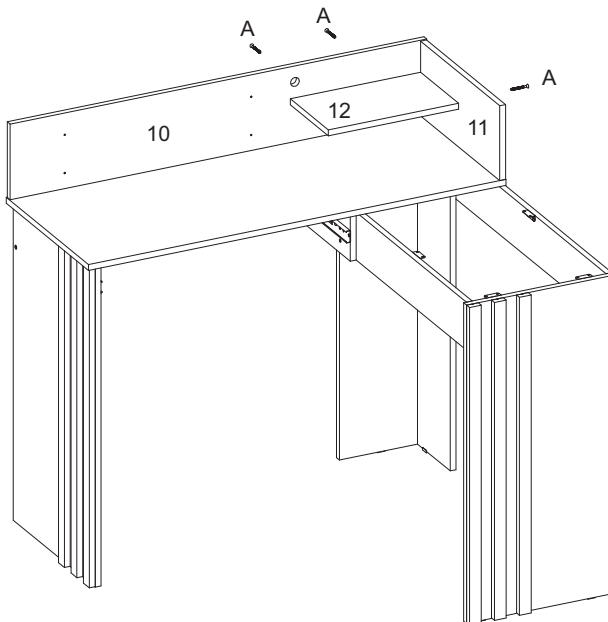

14° PASSO - Fixar peça 13 nas peças 2,6 e 7

14° STEP - Fix part 13 to parts 2, 6, and 7.

14° PASO - Fijar la parte 13 a las partes 2, 6 y 7.

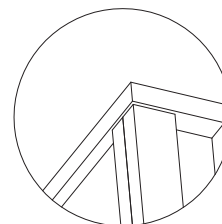
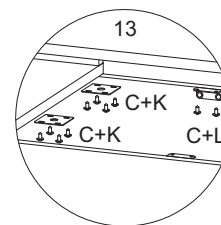
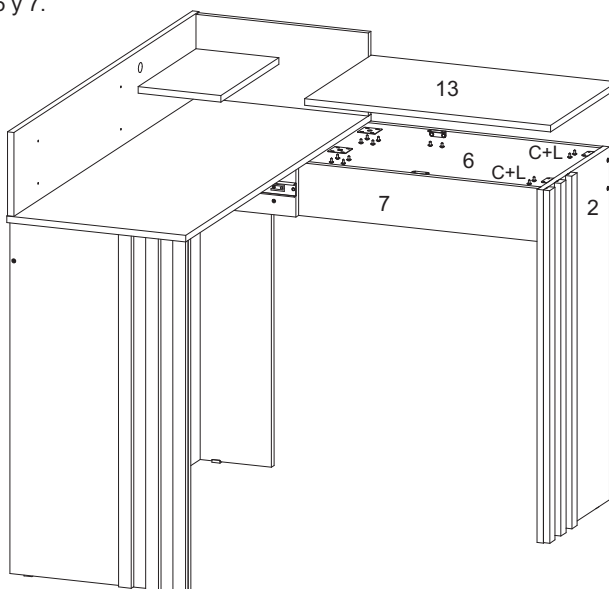

15° PASSO - Fixar peça 14 na peça 10

15° STEP - Fix part 14 to part 10.

15° PASO - Fijar la parte 14 a las parte 10.

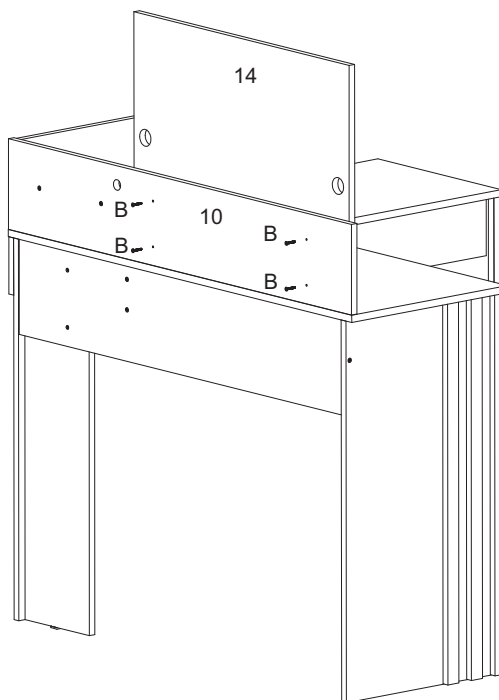

Alinhar a frente com 25 mm  
Align the front with 25 mm  
Alinee el frente con 25 mm

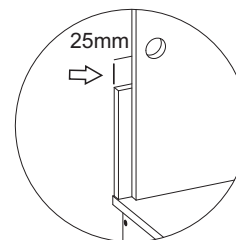

16° PASSO - Encaixar o kit led nas peças 10 e 14

16° STEP - Fit the LED kit into parts 10 and 14.

16° PASO - Coloque el kit LED en las piezas 10 y 14

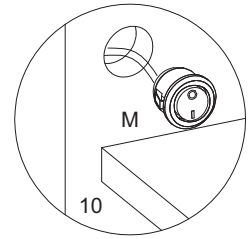
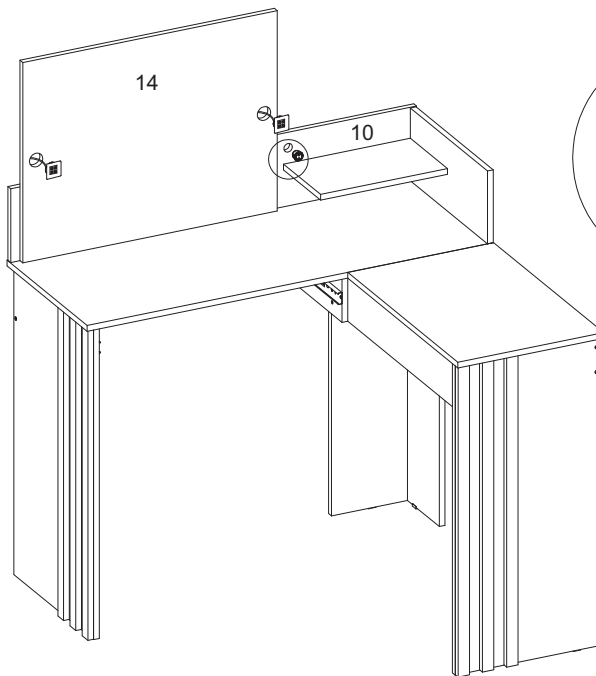
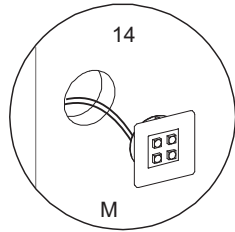
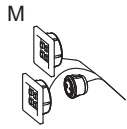

17° PASSO - Fixar o acessório N na peça 14 utilizando o acessório O

17° STEP - Attach accessory N to part 14 using accessory O

17° PASO - Conecte el accesorio N a la pieza 14 usando el accesorio O

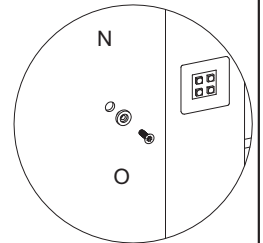
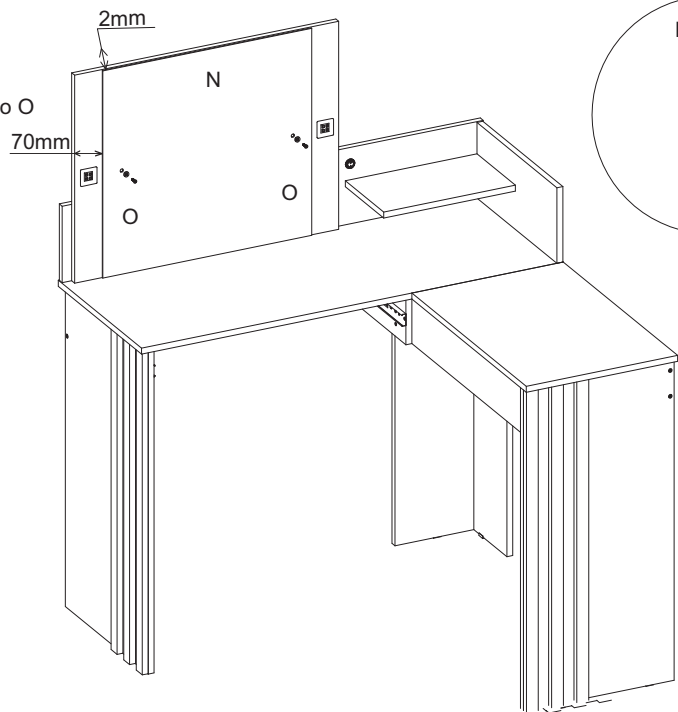

18° PASSO - Fixar as peças 17 nas peças 16 e 18

18° STEP - Fix pieces 17 to pieces 16 and 18

18° PASO - Fijar las piezas 17 a las piezas 16 y 18.

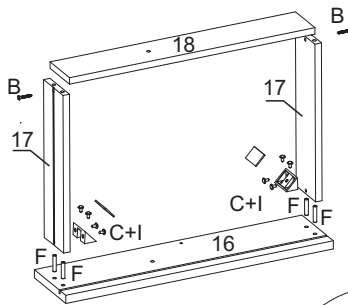

Utilizar cola nos encaixe dos acessorio F  
Use glue to fit two accessories F  
Utilice pegamento en las juntas F del accesorio.

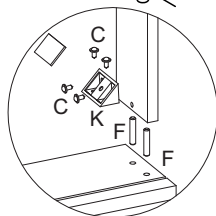
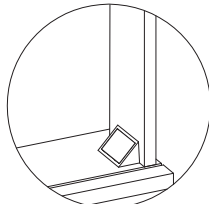

19° PASSO - Fixar a peça 20 nas peças 17 e 18

19° STEP - Fix piece 20 to pieces 17 and 18

19° PASO - Fijar la pieza 20 a las piezas 17 y 18

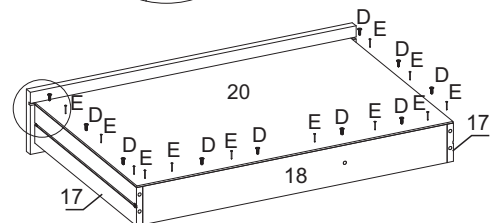
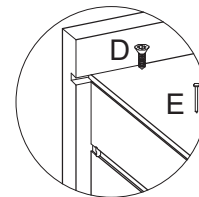

20° PASSO - Fixar o acessório G no canal da peça 17

20° STEP - Fix accessory G in the channel of part 17

20° PASO - Fijar accesorio G en el canal de la parte 17

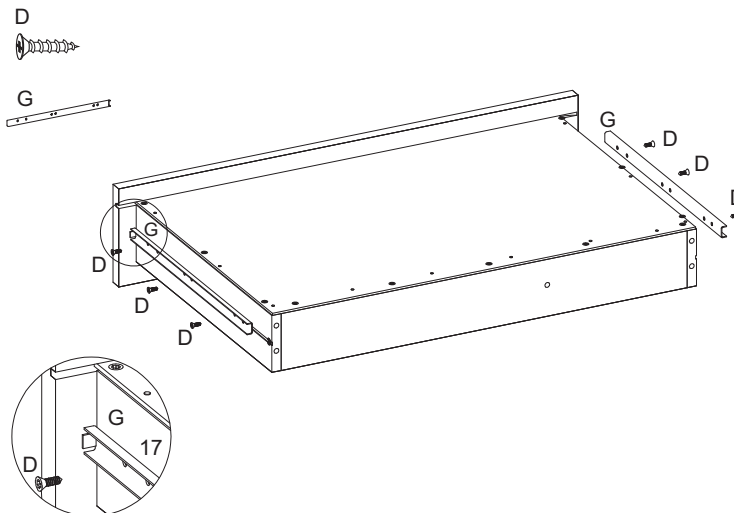

21° PASSO - Fixar a peça 19 nas peças 16 e 18

21° STEP - Attach piece 19 to pieces 16 and 18

21° PASO - Une la pieza 19 a las piezas 16 y 18.

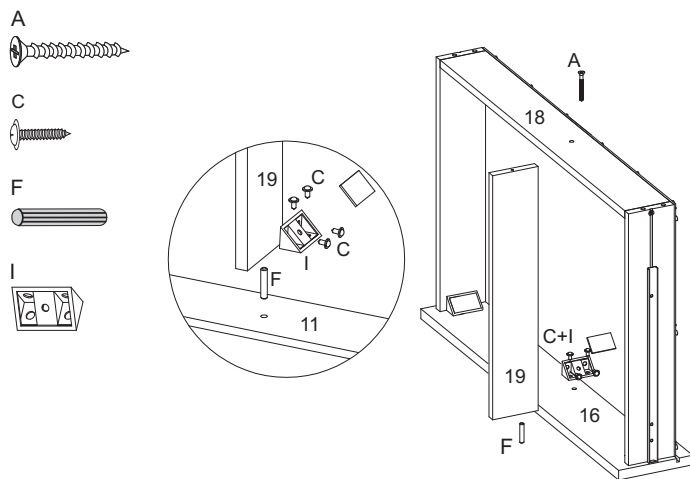

22° PASSO - Fixar o acessório J na peça 16, encaixar o acessório P entre as peças 16,17,18 e 19

22° STEP - Attach accessory J to part 16, fit accessory P between parts 16,17,18 and 19

22° PASO - Fije el accesorio J a la pieza 16, monte el accesorio P entre las piezas 16,17,18 y 19

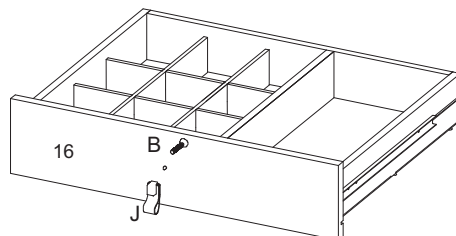
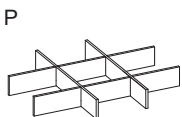
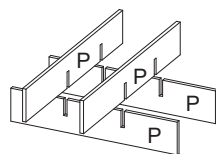

23° PASSO - Encaixar a gaveta no produto

23° STEP - Fit the drawer to the product

23° PASO - Ajustar el cajón al producto

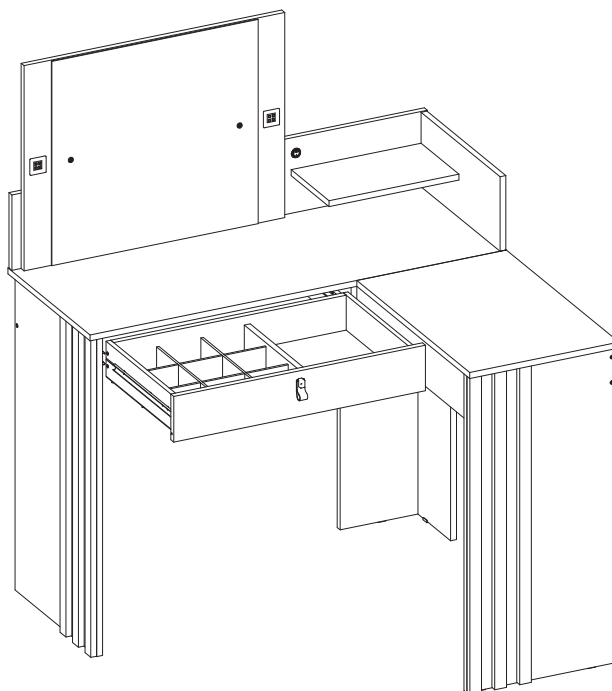

ASPECTO FINAL DO PRODUTO

FINAL APPEARANCE OF THE PRODUCT

ASPECTO FINAL DEL PRODUCTO

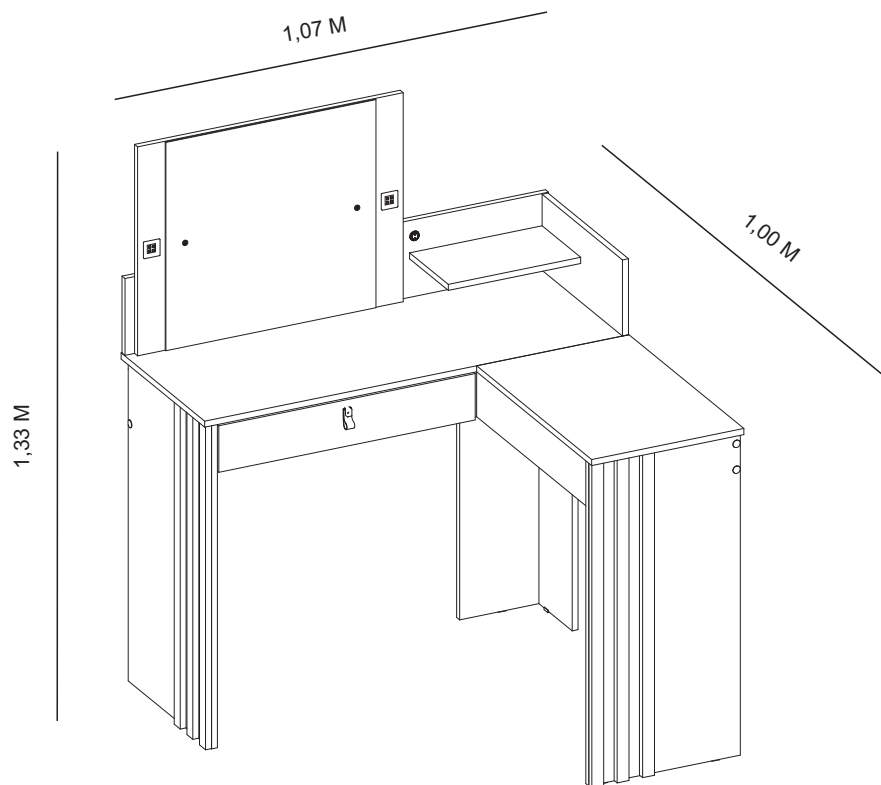

VISTA SUPERIOR

TOP VIEW

VISTA SUPERIOR

