

Roupeiro / Ropero / Wardrobe

MILANO

BC-3250

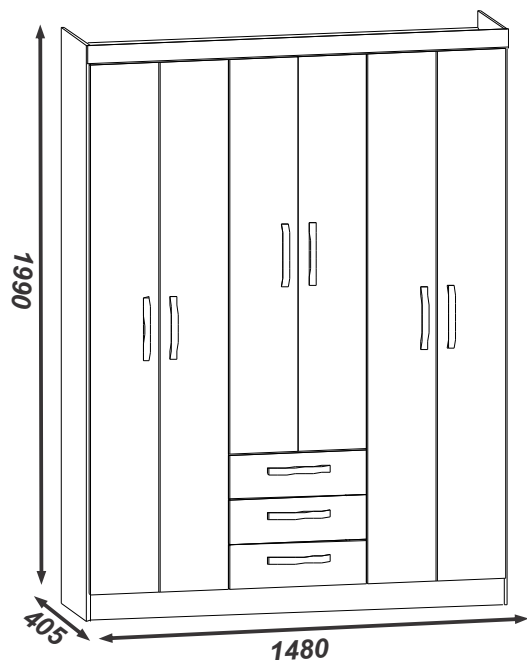

Instruções para a montagem do produto:

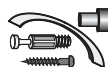

Separe as peças e acessórios de maneira organizada.

Separate the parts and accessories in an organized way.

Separe las piezas y accesorios de forma organizada



Forrar o chão com o papelão das embalagens.

Cover the floor with the cardboard from the pack.

Cubre el suelo con el cartón de los bultos.



É necessário duas pessoas para montar o produto.

It's necessary two people to assembly the product.

Se requiere dos personas para montar el producto.

Ferramentas necessárias (não fornecidas)

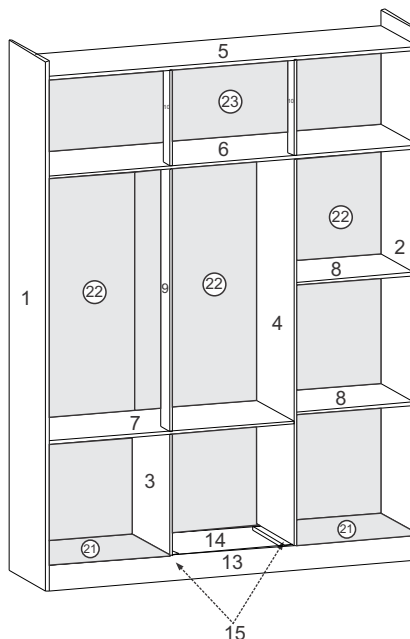
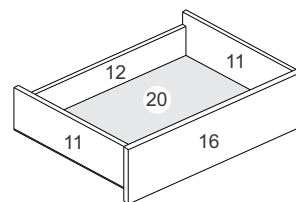
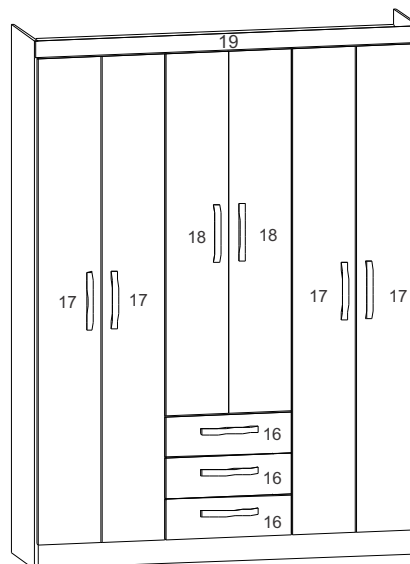
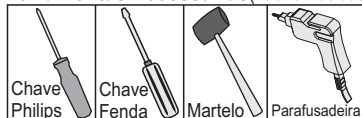

POR

- 01-LATERAL ESQUERDA
- 02-LATERAL DIREITA
- 03-DIVISAO ESQUERDA
- 04-DIVISAO DIREITA
- 05-TAMPO SUPERIOR
- 06-TAMPO MALEIRO
- 07-TAMPO CENTRAL
- 08-PRATELEIRAS (2x)
- 09-PILASTRA MAIOR
- 10-PILASTRA MENOR (2x)
- 11-LATERAL DE GAVETA (6x)
- 12-TRASEIRO DE GAVETA (3x)
- 13-RODAPÉ FRONTAL
- 14-RODAPÉ TRASEIRO
- 15-TRAVESSA DE RODAPÉ (2x)
- 16-FRENTE DE GAVETA
- 17-PORTA LATERAL (4X)
- 18-PORTA CENTRAL (2X)
- 19-FRONTAL
- 20-FUNDO DE GAVETA (3X)
- 21-TAMPO INFERIOR (2x)
- 22-COSTAS (3X)
- 23-COSTA MALEIRO

ESP

- 01-LATERAL IZQUIERDA
- 02-LATERAL DERECHA
- 03-DIVISORIA IZQUIERDA
- 04-DIVISORIA DERECHA
- 05-TAPA SUPERIOR
- 06-TAPA MALEIRO
- 07-TAPA CENTRAL
- 08-ESTANTES (2x)
- 09-PILASTRA MAJOR
- 10-PILASTRA MENOR (2x)
- 11-LATERAL DEL CAJÓN(6x)
- 12-TRASERO DEL CAJÓN (3x)
- 13-ZÓCALO FRONTAL
- 14-ZÓCALO TRASERO
- 15-TRAVESSAÑO DEL ZÓCALO (2x)
- 16-FRENTE DEL CAJÓN
- 17-PUERTA LATERAL (4X)
- 18-PUERTA CENTRAL (2X)
- 19-FRONTAL
- 20-FONDO DEL CAJÓN(3X)
- 21-TAPA INFERIOR (2x)
- 22-DORSO(3X)
- 23-DORSO MALERO

ENG

- 01-LEFT SIDE
- 02-RIGHT SIDE
- 03-LEFT DIVIDER
- 04-RIGHT DIVIDER
- 05-UPPER TOP
- 06-LUGAGGE TOP
- 07-CENTRAL TOP
- 08-SHELF (2x)
- 09-BIGGER PILASTER
- 10-LITTLE PILASTER (2x)
- 11-DRAWER SIDE(6x)
- 12-DRAWER BACK (3x)
- 13-FRONT BASE BOARD
- 14-BACK BASE BOARD
- 15-BASE BOARD CROSSBAR (2x)
- 16-DRAWER FRONT (3X)
- 17-SIDE DOOR (4X)
- 18-CENTRAL DOOR (2X)
- 19-FRONT
- 20-DRAWER BOTTOM(3X)
- 21-LOWER TOP (2x)
- 22-BACK PANEL (3X)
- 23-LUGAGGE BACK PANEL

DIMENSÕES PEÇAS PRONTAS

- 01-1990 X 386 X 12
- 02-1990 X 386 X 12
- 03-455 X 385 X 12
- 04-1452 X 385 X 12
- 05-1452 X 385 X 12
- 06-1452 X 385 X 12
- 07-964 X 385 X 12
- 08-476 X 337 X 12
- 09-985 X 95 X 12
- 10-360 X 65 X 12
- 11-338 X 95 X 12
- 12-428 X 65 X 12
- 13-1452 X 95 X 15
- 14-1452 X 95 X 15
- 15-337 X 65 X 15
- 16-484 X 151 X 15
- 17-1830 X 241 X 15
- 18-1365 X 241 X 15
- 19-1478 X 63 X 15
- 20-450 X 341 X 3
- 21-476 X 384 X 3
- 22-1470 X 488 X 3
- 23-1464 X 376 X 3

DIMENSIONES DE LAS PEZAS PRONTAS

- 01-1990 X 386 X 12
- 02-1990 X 386 X 12
- 03-455 X 385 X 12
- 04-1452 X 385 X 12
- 05-1452 X 385 X 12
- 06-1452 X 385 X 12
- 07-964 X 385 X 12
- 08-476 X 337 X 12
- 09-985 X 95 X 12
- 10-360 X 65 X 12
- 11-338 X 95 X 12
- 12-428 X 65 X 12
- 13-1452 X 95 X 15
- 14-1452 X 95 X 15
- 15-337 X 65 X 15
- 16-484 X 151 X 15
- 17-1830 X 241 X 15
- 18-1365 X 241 X 15
- 19-1478 X 63 X 15
- 20-450 X 341 X 3
- 21-476 X 384 X 3
- 22-1470 X 488 X 3
- 23-1464 X 376 X 3

DIMENSIONS READY MODE PARTS

- 01-1990 X 386 X 12
- 02-1990 X 386 X 12
- 03-455 X 385 X 12
- 04-1452 X 385 X 12
- 05-1452 X 385 X 12
- 06-1452 X 385 X 12
- 07-964 X 385 X 12
- 08-476 X 337 X 12
- 09-985 X 95 X 12
- 10-360 X 65 X 12
- 11-338 X 95 X 12
- 12-428 X 65 X 12
- 13-1452 X 95 X 15
- 14-1452 X 95 X 15
- 15-337 X 65 X 15
- 16-484 X 151 X 15
- 17-1830 X 241 X 15
- 18-1365 X 241 X 15
- 19-1478 X 63 X 15
- 20-450 X 341 X 3
- 21-476 X 384 X 3
- 22-1470 X 488 X 3
- 23-1464 X 376 X 3

Ferragens/Herraje/Hardware:

Cód	Itens	Quan
330	A Cavilhas 6 x 30 Clavija Bowel	20
0289	B Parafuso 3,5 x 40 c/c Tornillo Screw	43
0538	C Porca cilíndrica Tuerca cilíndrica Cylindrical nut	29
151	D Dobradiça metal 26 mm Bisagra Hinge	18
0744	E Taxa 13 x 15 Clavo 13 x 15 Nail 13 x 15	12
0296	F Taxa 10 x 7 Clavo 10 x 7 Nail 10 x 7	90
0283	G Parafuso 3,5 x 12 c/c Tornillo Screw	132
0438	H Cantoneira Esquinera Cantoneira	17
0477	I Cola Pegamento Glue	01
0285	J Parafuso 3,5 x 25 c/f Tornillo Screw	18
----	K Puxador 128 mm (118 SR) Tirador Handle	09
0645	L Pino Suporte Prateleira Soporte Support	02
0279	M Fixador de costa Fixador de espalda Fix back	18
----	N Cabideiro 958mm Perchero Holding	01
----	O Sapata U 15 X 15 Preto Pata Feet	08
3049	P Corrediça metálica Slim Rieles Slides	03
4738	Q Cantoneira Plástica Refuerzo de Plástico Plastic gusset	03
5159	R Cavilhas 6 x 50 Clavija Bowel	03
1413	S Suporte cabide sem furo CINZA	02
1415	T Suporte cabideiro Soporte percha Hanger holding	01
0286	U Parafuso 3,5 x 22 c/c Tornillo Screw	05
----	O Perfil 980 mm Perfil Profile	01



Montagem da gaveta Armado de los cajones Drawer Assembly

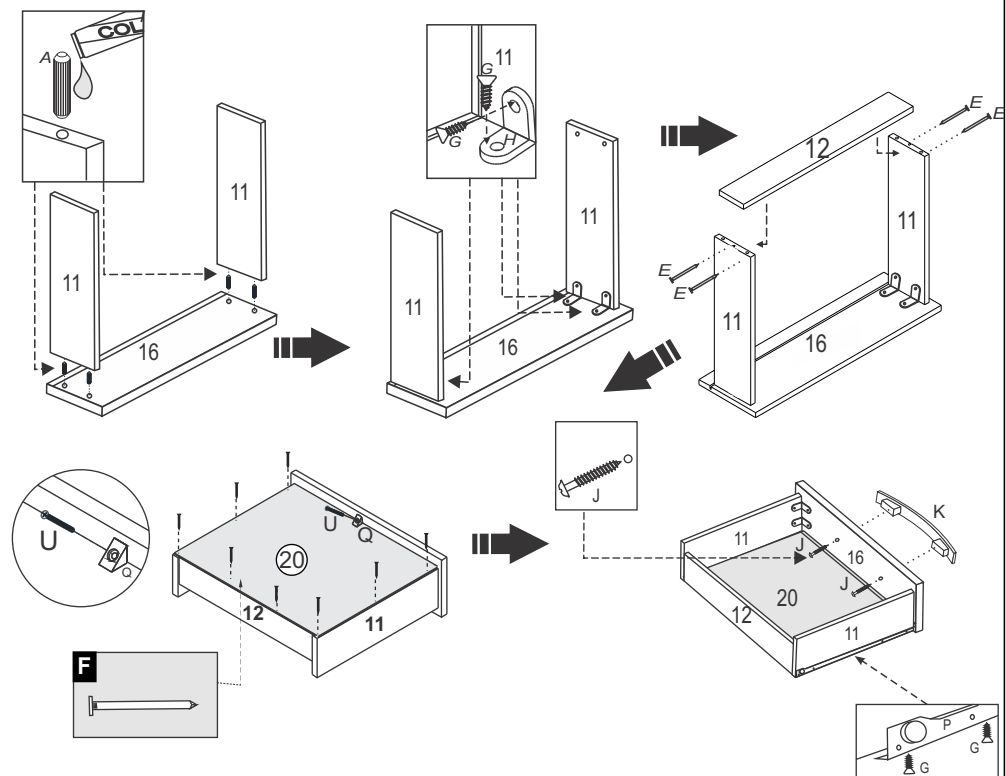

1º Passo 1º Paso 1º Step

Atenção! ao parafusar a corrediça,
cuidar o lado certo.

Atención! al atornillar la corredera,
cuidar para que esté en el lado correcto

Attention! When screwing the slide,
take care to do the right side

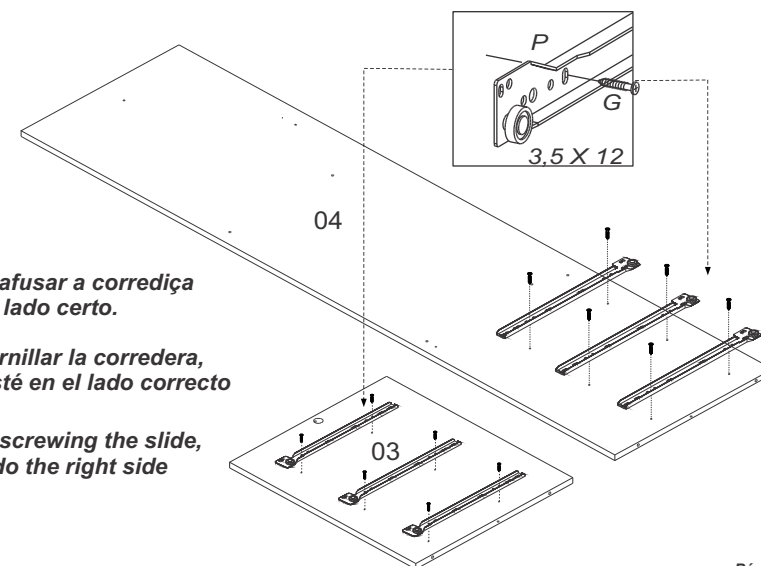

2º Passo
2º Paso
2º Step

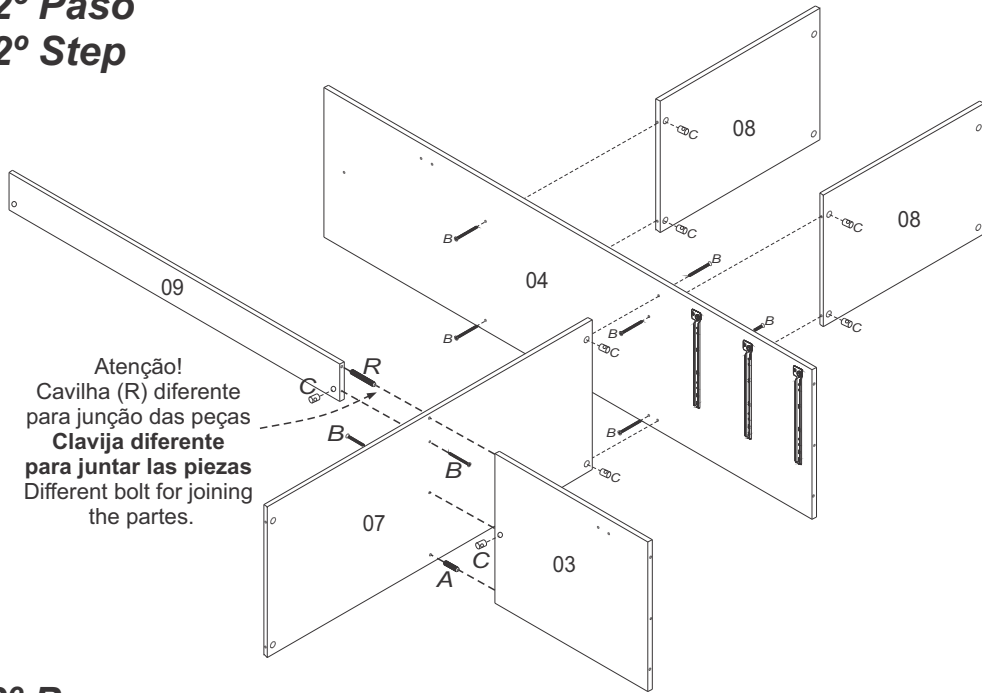

3º Passo
3º Paso
3º Step

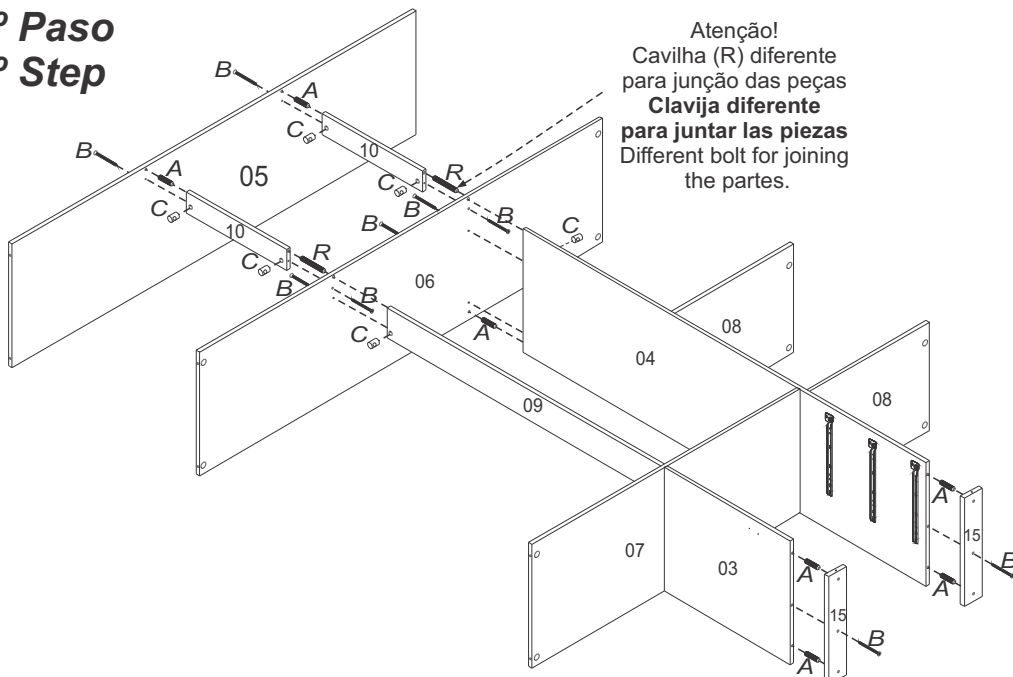

4º Passo
4º Paso
4º Step

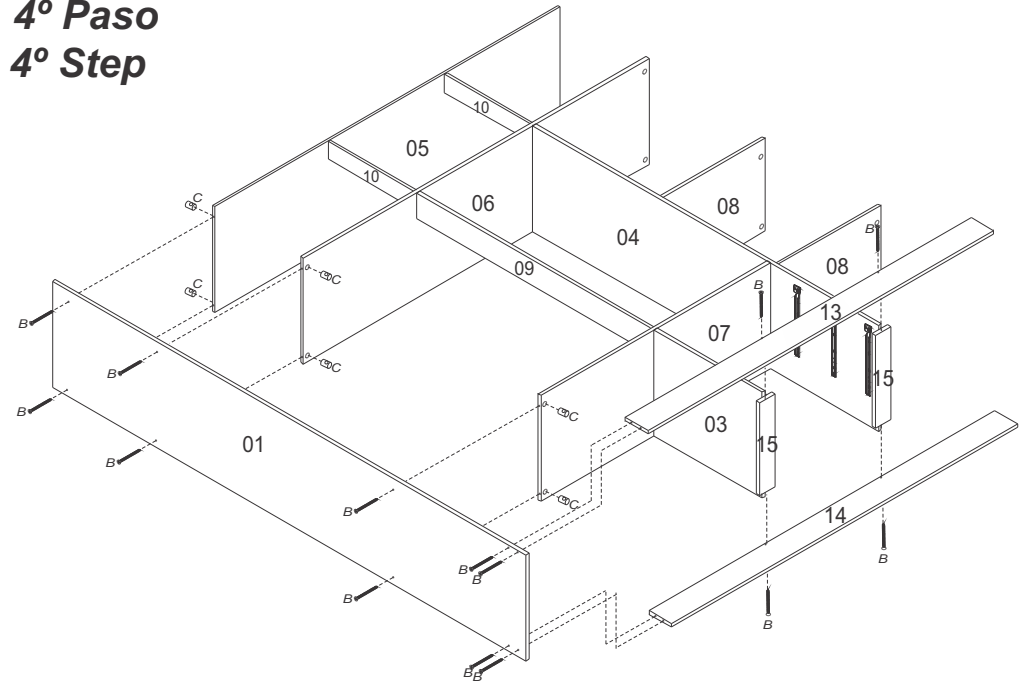

5º Passo
5º Paso
5º Step

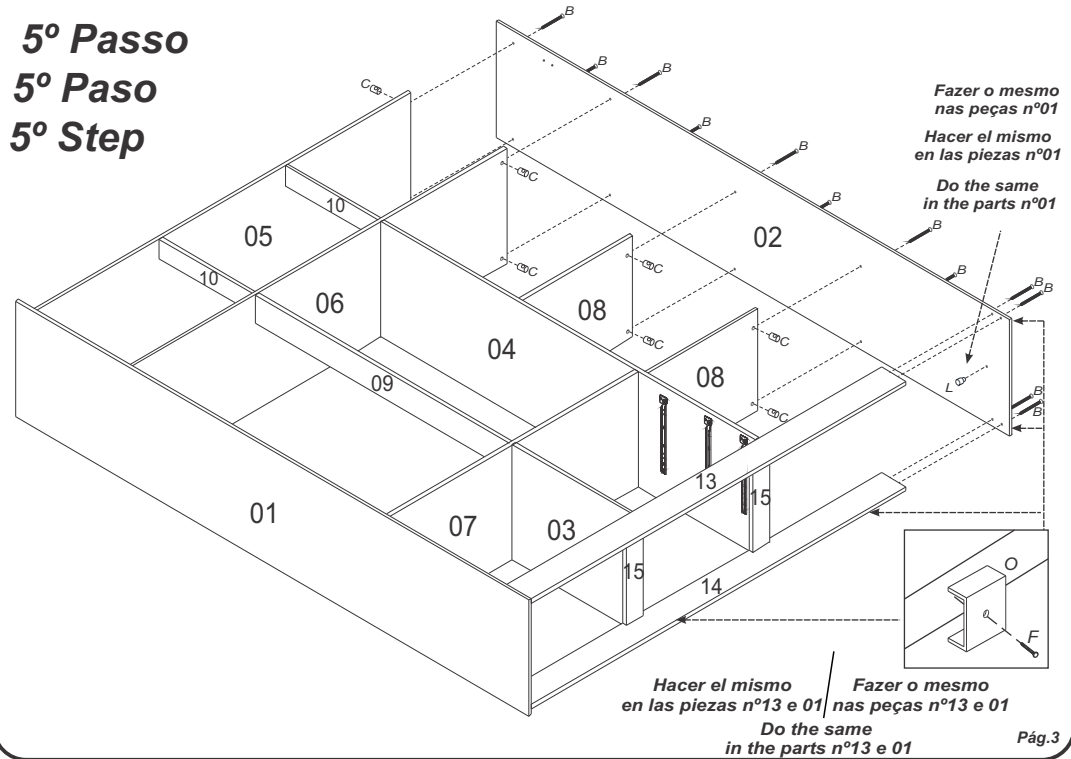

6º Passo
6º Paso
6º Step

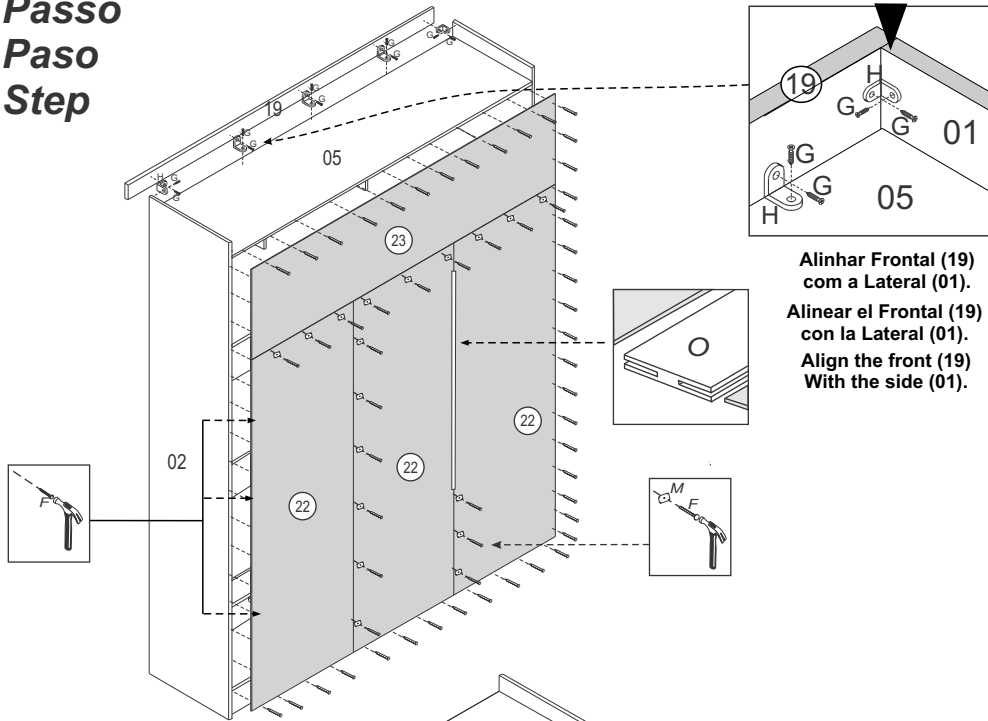

Alinhar Frontal (19) com a Lateral (01).
 Alinear el Frontal (19) con la Lateral (01).
 Align the front (19) With the side (01).

7º Passo
7º Paso
7º Step

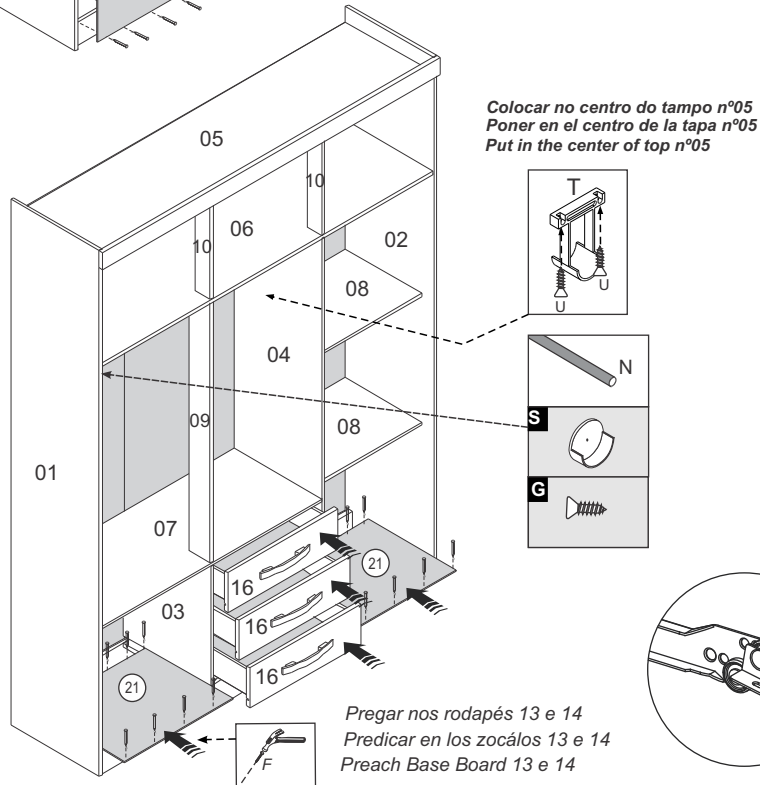

Colocar no centro do tampo nº05
 Poner en el centro de la tapa nº05
 Put in the center of top nº05

Pregar nos rodapés 13 e 14
 Predicar en los zocólos 13 e 14
 Preach Base Board 13 e 14

8º Passo
8º Paso
8º Step

Montagem das dobradiças nas portas (17,18) colocando calço e dobradiça.
 Montaje de las bisagras en las puertas (17,18) Poner la base y bisagra.
 The assembly of the Hinge in the door (17,18) putting the base of Hinge and hinge.

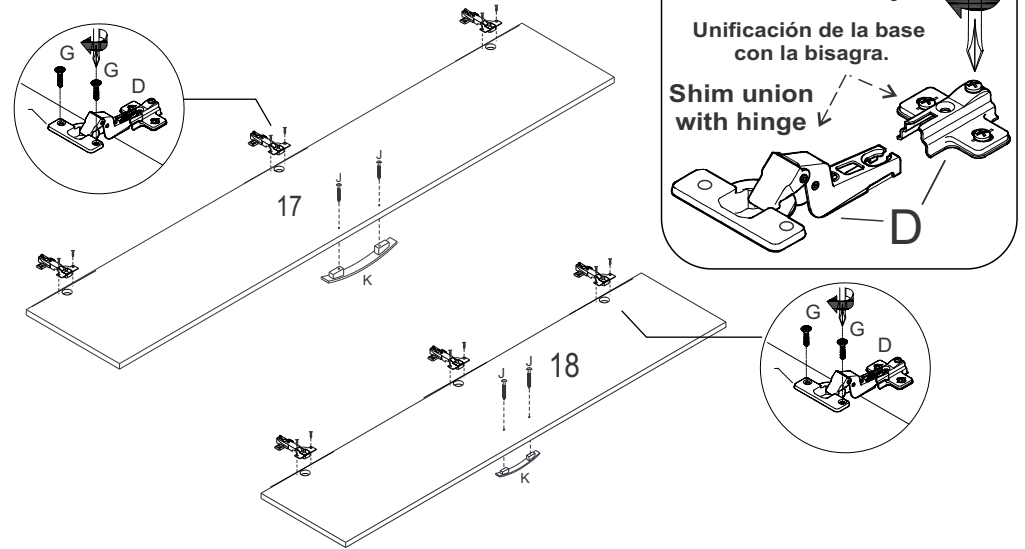

9º Passo
9º Paso
9º Step

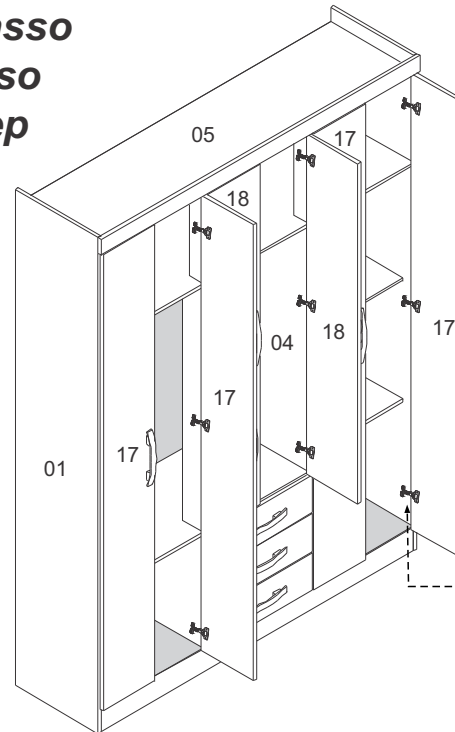

EM TODAS AS PORTAS DA MESMA MANEIRA
 EN TODAS LAS PUERTAS DE LA MISMA MANERA
 ON ALL DOORS THE SAME WAY

REGULAGEM / REGLAJE / ADJUSTMENT



Possuem marcação de fixação das dobradiças nas peças. (01,02,03,04).

Tienen perforación de fijación de las bisagras en las piezas (01,02,03,04).

There are markings of hinges assembly in the parts (01,02,03,04).

