

# ASSEMBLY INSTRUCTIONS MANUAL DE MONTAGEM / INSTRUCCIONES DE ARMADO

FETTUCCINE CABINET 2 DOORS 31"  
BALCAO 2 PORTAS 800MM FETTUCCINE  
GABINETE 2 PUERTAS 800MM FETTUCCINE

Reference  
Referência  
Referencia

**220339**

Revised  
Revisão  
Revisión

**00**



ENGLISH  
PORTUGUÊS  
ESPAÑOL

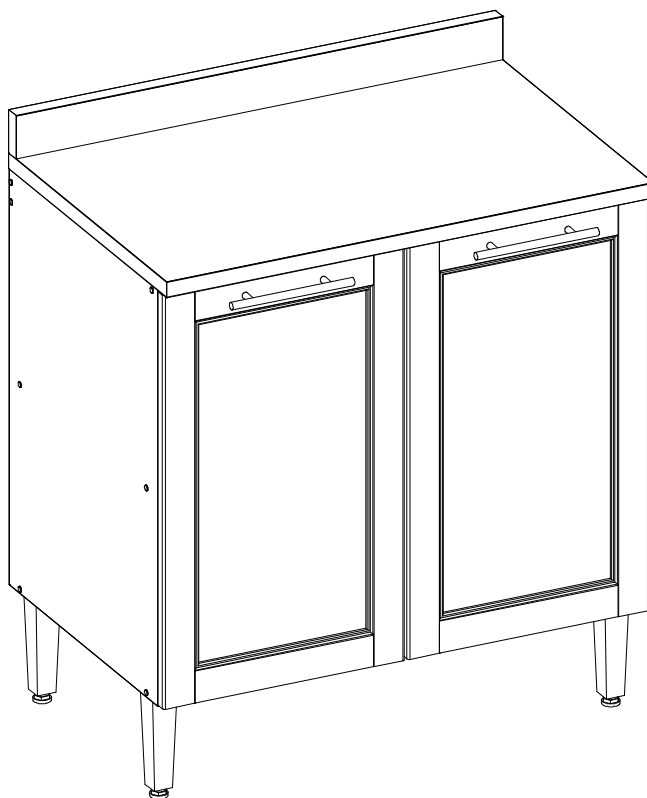

MAXIMUM RECOMMENDED WEIGHT  
BEING THIS EVENLY DISTRIBUTED.

PESO MÁXIMO RECOMENDADO SENDO  
ESTE DISTRIBUÍDO UNIFORMEMENTE.

PESO MÁXIMO RECOMENDADO SIENDO  
ESTE UNIFORMEMENTE DISTRIBUIDO.

	LB	KG
–		
F	22	10
H	44	20

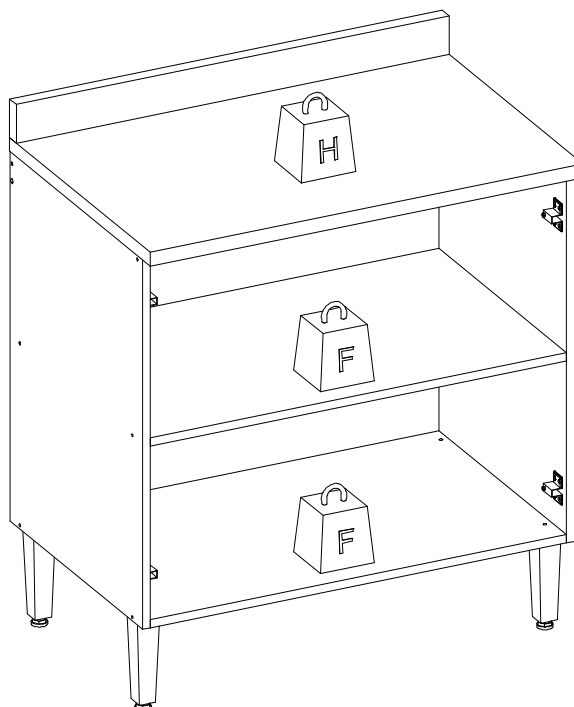

Nº	Measures_Inches	Medidas_cm	Qty./Qtd.
01	31 1/2 x 20 1/2 x 1	80.0 x 52.0 x 2.5	1
02	31 1/2 x 2 3/4 x 1	80.0 x 7.0 x 2.5	1
03	26 3/8 x 19 1/4 x 5/8	67.0 x 49.0 x 1.5	1
04	26 3/8 x 19 1/4 x 5/8	67.0 x 49.0 x 1.5	1
05	30 1/4 x 18 1/2 x 5/8	76.9 x 47.1 x 1.5	1
06	30 1/4 x 19 1/4 x 5/8	76.9 x 49.0 x 1.5	1
07	30 1/4 x 2 3/4 x 5/8	76.9 x 7.0 x 1.5	1
08	30 1/4 x 2 3/4 x 5/8	76.9 x 7.0 x 1.5	1
09	30 7/8 x 13 x 1/8	78.3 x 32.9 x 0.3	2
40	26 1/4 x 15 5/8 x 3/4	66.6 x 39.7 x 1.8	2

## PARTS IDENTIFICATION IDENTIFICAÇÃO DAS PEÇAS / IDENTIFICACIÓN DE LAS PIEZAS

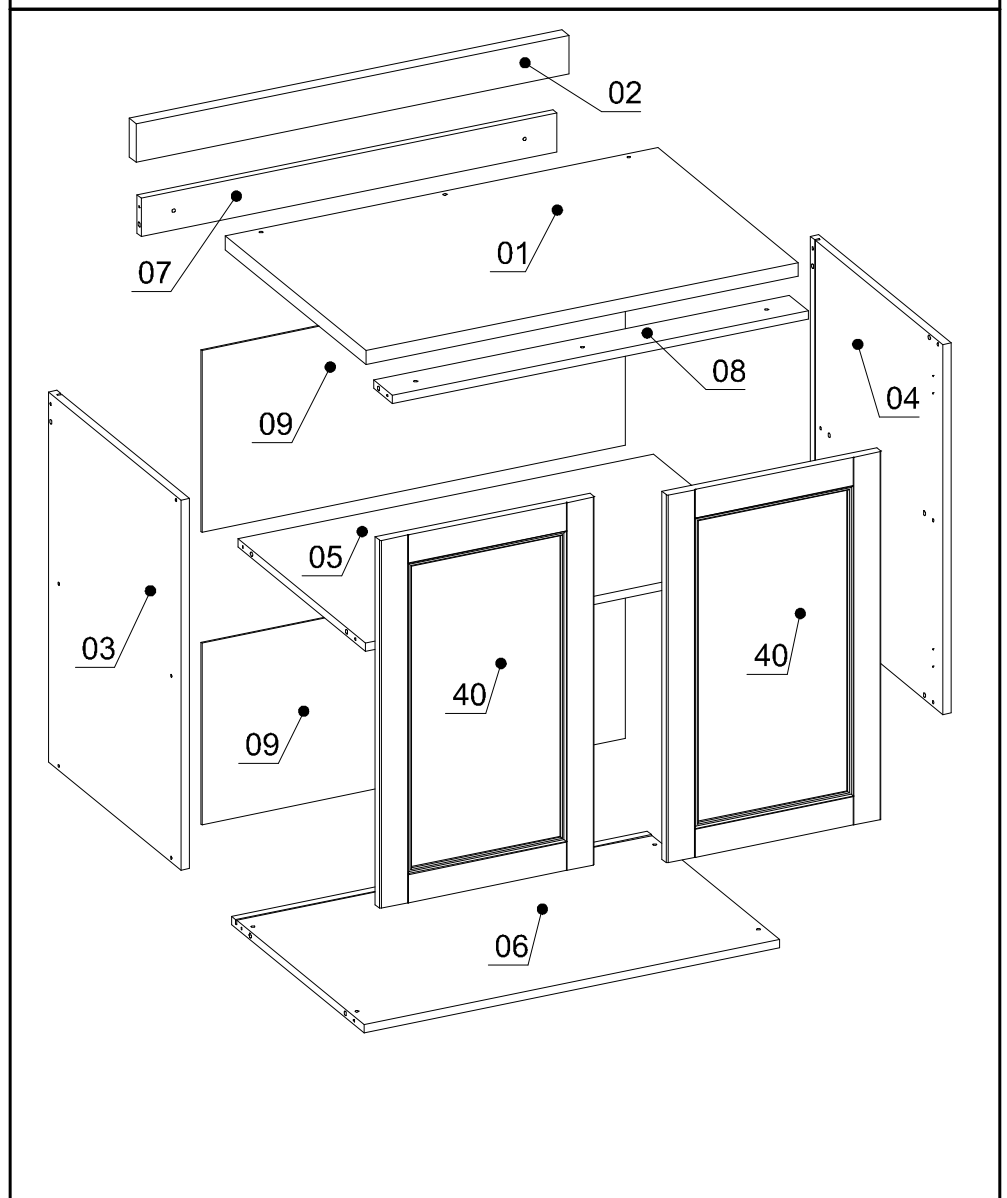

### YOU WILL NEED / VOCÊ VAI PRECISAR DE / USTED NECESITARÁ

Tools not supplied / Ferramentas não fornecidas / Herramientas no incluidas

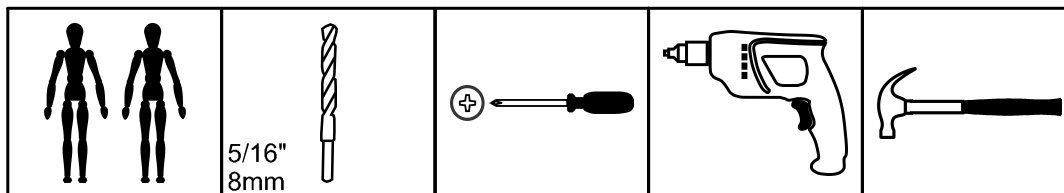

2 People  
2 Pessoas  
2 Personas

5/16"  
8mm  
Drill bit  
Broca  
Taladro

Screwdriver Phillips  
Chave Phillips  
Destornillador cruz

Drill machine  
Furadeira  
Taladro

Hammer  
Martelo  
Martillo











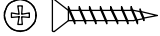

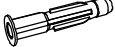
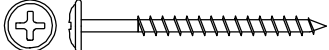

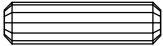
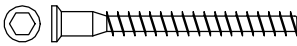

The separation of the accessories before you start the assembly will facilitate the same. In case of doubt on the size of the screws and bolts, use the ruler to bottom of page 3.

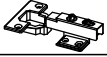
A separação dos acessórios antes de iniciar a montagem facilitará a mesma. Em caso de dúvida no tamanho dos parafusos e cavilhas, utilize a régua ao final da página 3.

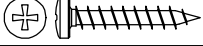
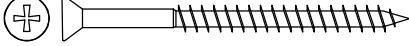
La separación de los accesorios antes de comenzar el armado facilitará el mismo. En caso de duda sobre el tamaño de los tornillos y taquetes, utilice la regla al pie de página 3.

## IDENTIFICATION OF ACCESSORIES IDENTIFICAÇÃO DOS ACESSÓRIOS/ IDENTIFICACIÓN DE ACCESORIOS

A4		Metalic bracket / Cantoneira de metal / Suporte de metal	22x22 mm	4
A8		Flat head screw / Parafuso chato / Tornillo de cabeza plana	3,5x20 mm	6
A24		Handle / Puxador Haste / Tirador	128 mm	2
A24B		Flanged head screw / Parafuso flangeado / Tornillo de cabeza flangeada	M4x25 mm	4
B3		Bushing / Bucha expansiva / Tapón	8x50 mm	2
C		Flanged head screw / Parafuso flangeado / Tornillo de cabeza flangeada	4,5x45 mm	4
C1		Metal claw / Garra de metal / Garra metal	-	4
E		Wooden dowel / Cavilha / Taquete	8x30 mm	12
G		Structural screw / Parafuso estrutural / Tornillo estrutural	5,0x50 mm	12
H		Allen key / Chave allen / Liave allen	3 mm	1
I		Structural screw cover/Tampa parafuso estrutural/Tapa tornillo estrutural	-	12
i4		Pan head screw / Parafuso panela / Tornillo de pan	5,0x70 mm	2
K11		Silicone stop / Batente de silicone / Tope de silicona	8 mm	2
M17		Metal hinge straight / Dobradiça reta / Bisagra recta	35 mm	4
N		Nail / Pregos / Clavo	10x10	4
o1		Triangular support / Suporte triangular / Soporte triangular	-	6
P		Pan head screw / Parafuso panela / Tornillo de pan	4,5x25 mm	3
Q4		Flat head screw / Parafuso chato / Tornillo de cabeza plana	4,5x60 mm	3
S		Pan head screw / Parafuso panela / Tornillo de pan	3,5x14 mm	32
X15		Foot / Pé Cônico FP / Pie	170 mm	4
Z		Plastic hole plugs / Tapa furo plástico / Tapones plásticos	8 mm	2

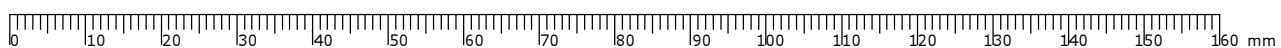

PRE-ASSEMBLE  
PRÉ-MONTAGEM / PRE ARMADO

01

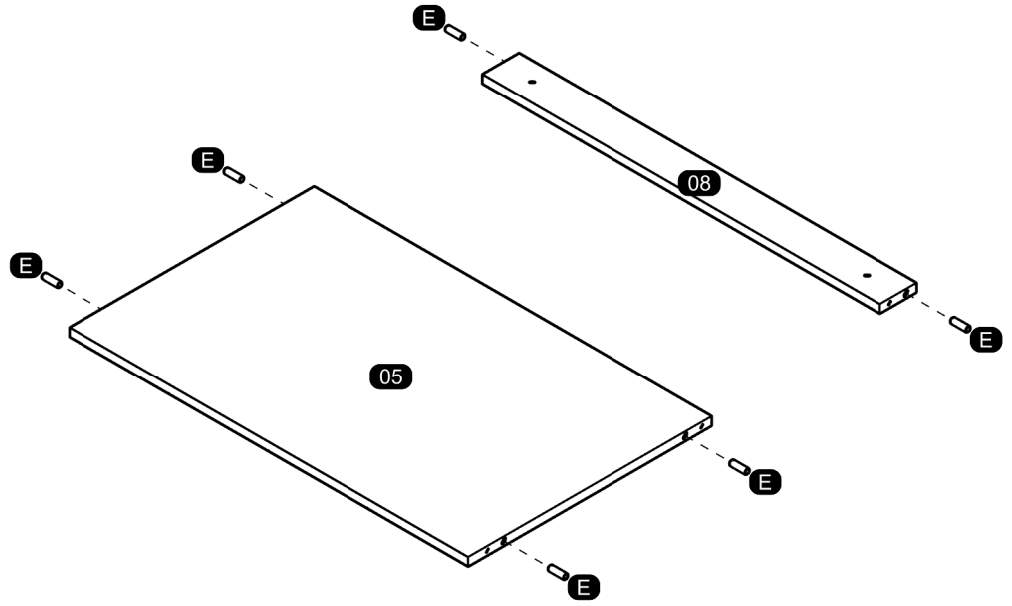
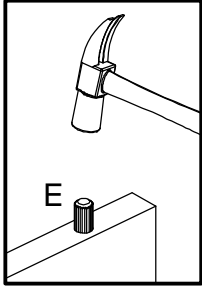

02

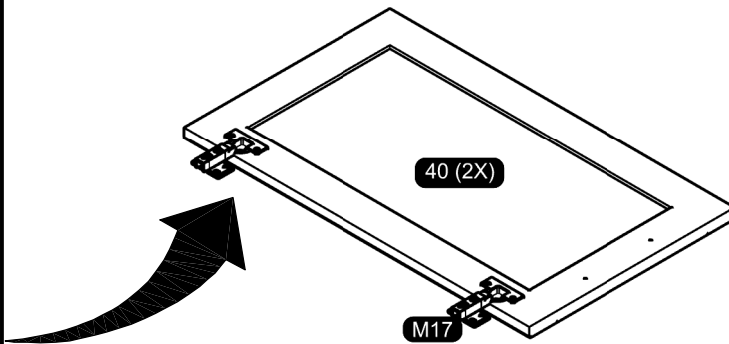
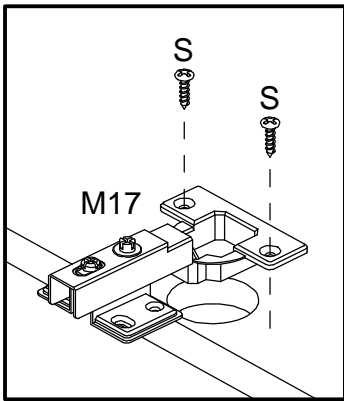

03

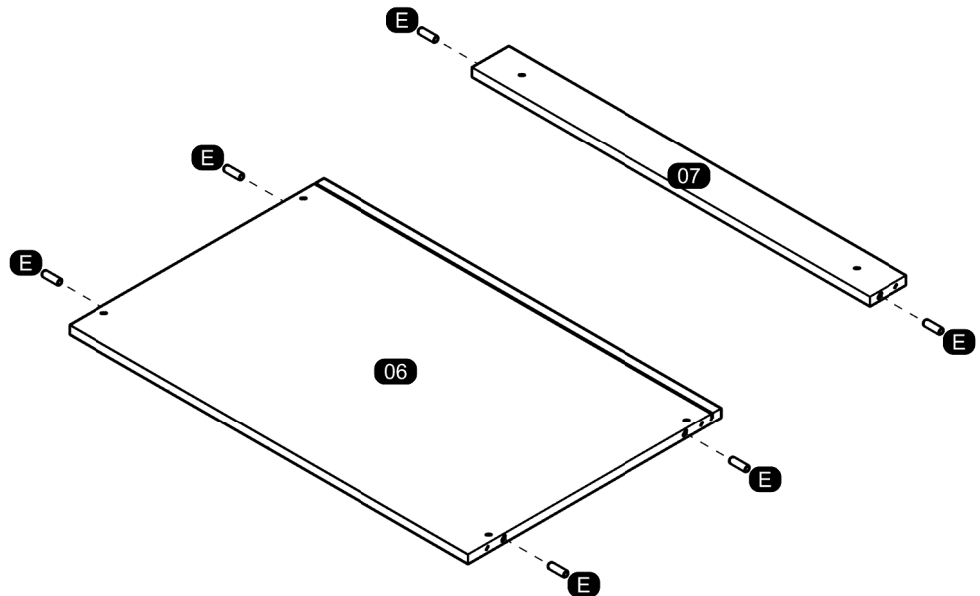

ASSEMBLY  
MONTAGEM / ARMADO

04

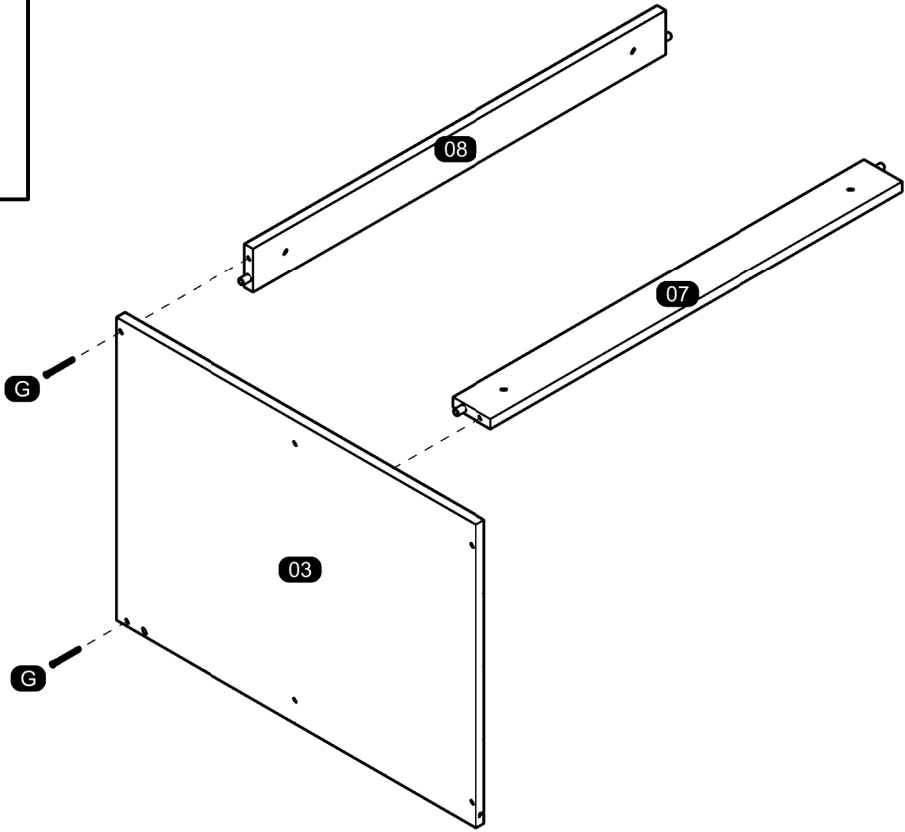
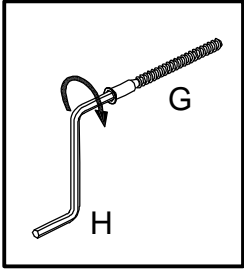

05

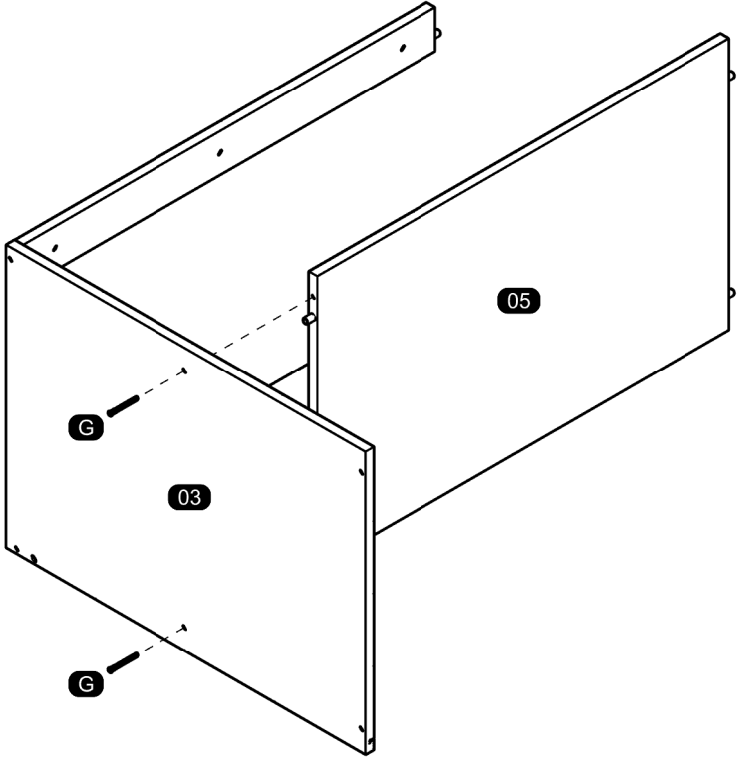

06

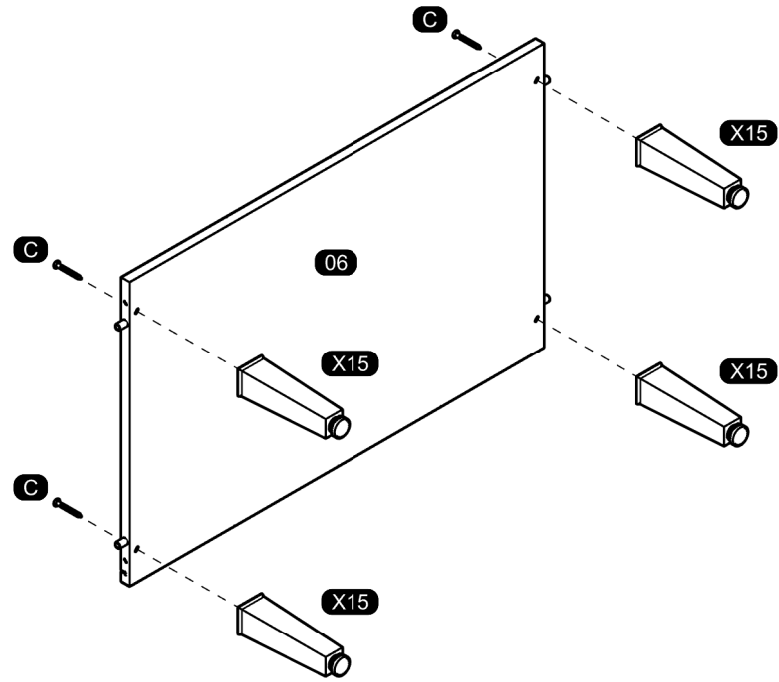

07

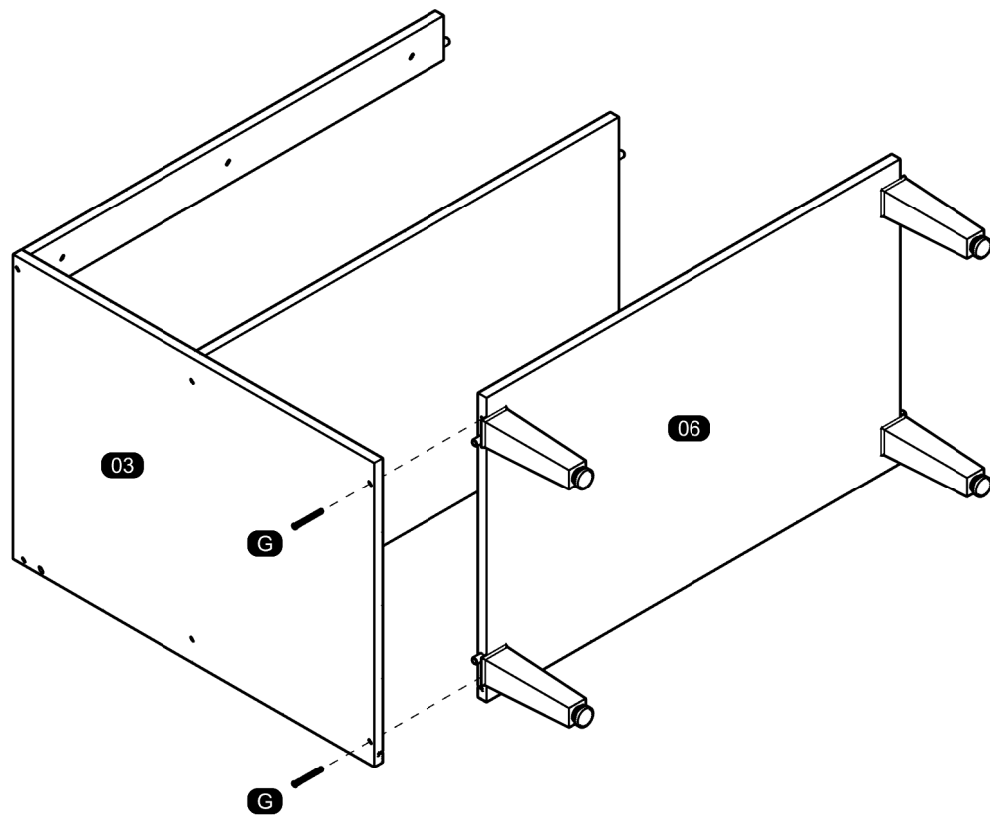

08

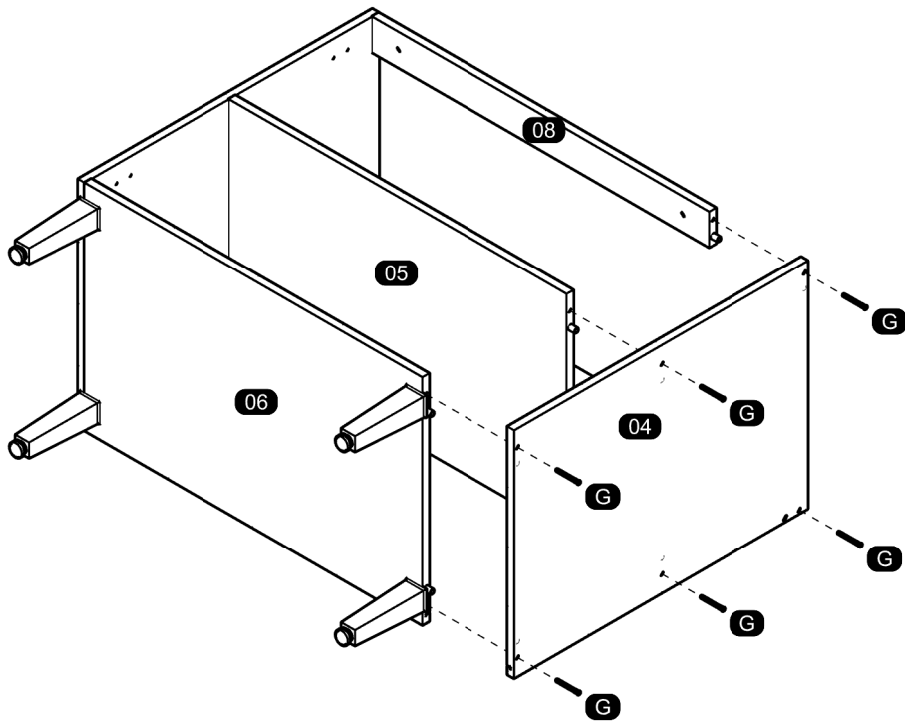

09

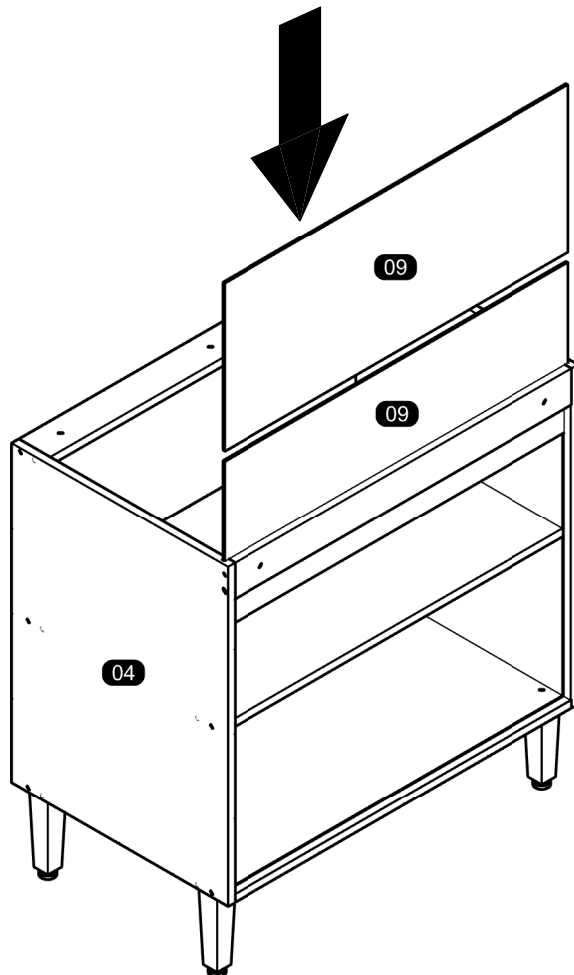
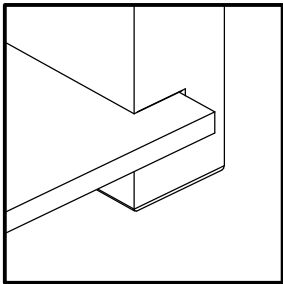

10

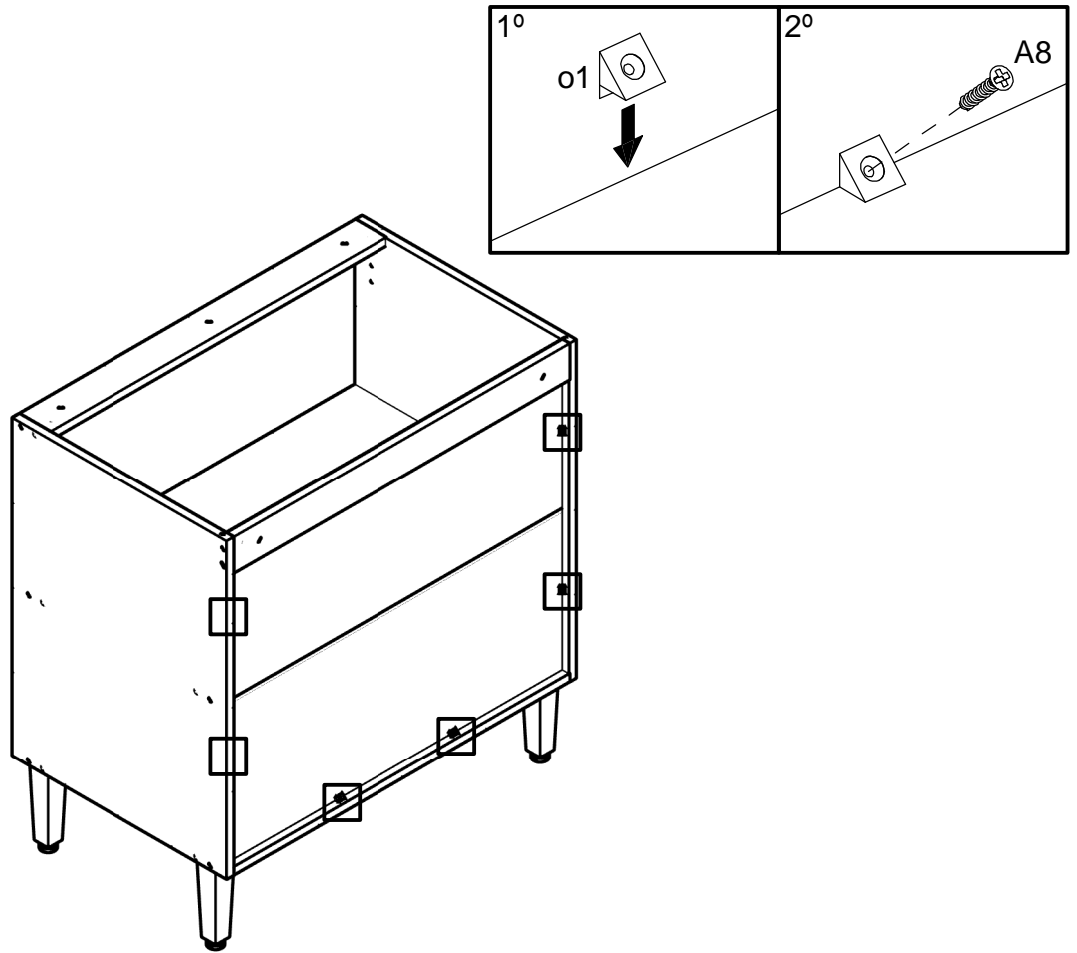

11

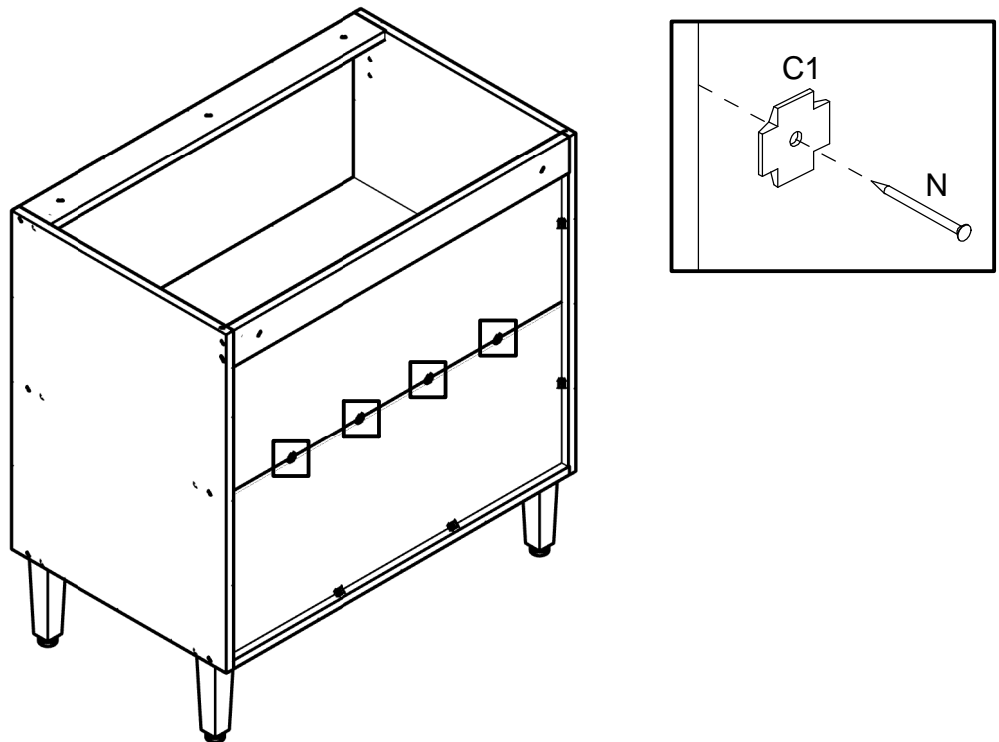



12

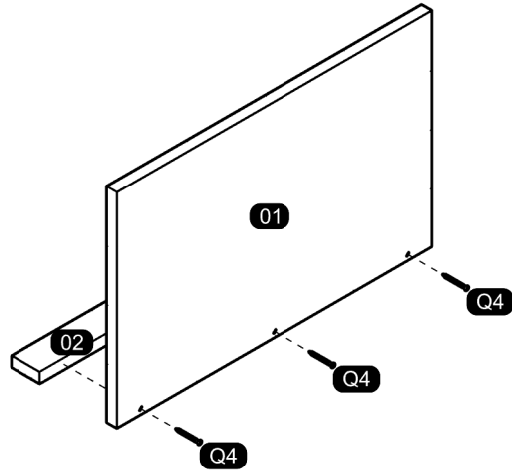

13

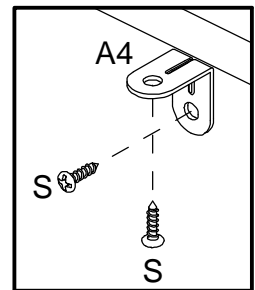
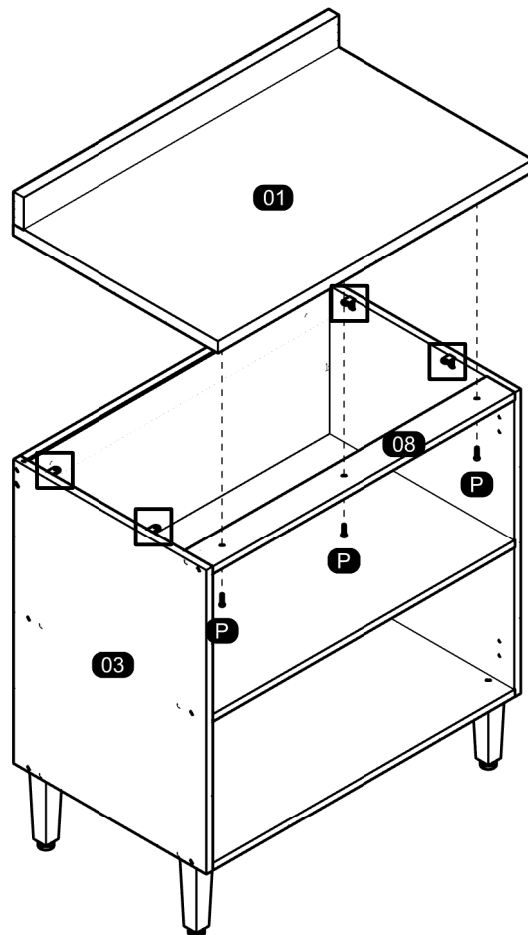

14

TO AVOID ANY INJURY THE FURNITURE MUST BE FIXED ON THE WALL. THANKS.  
PARA EVITAR QUALQUER ACIDENTE, É OBRIGATÓRIO FIXAR O MÓVEL NA PAREDE. OBRIGADO!  
PARA EVITAR CUALQUIER ACCIDENTE ES OBLIGATORIO ANCLAR EL MUEBLE EN LA PARED. GRACIAS.

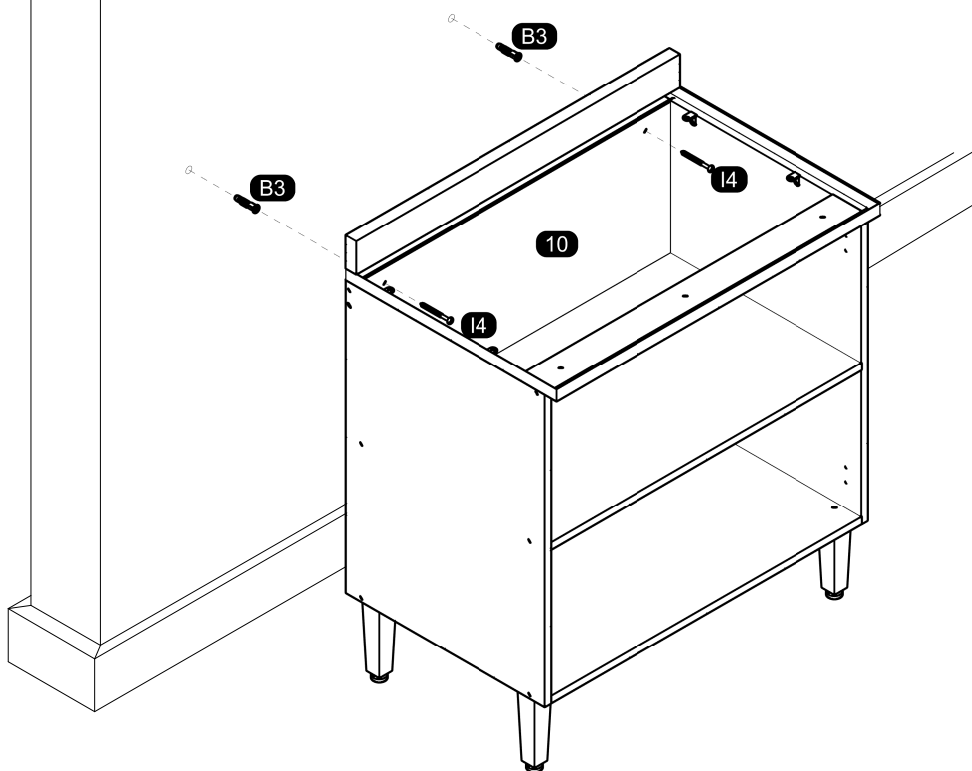

15

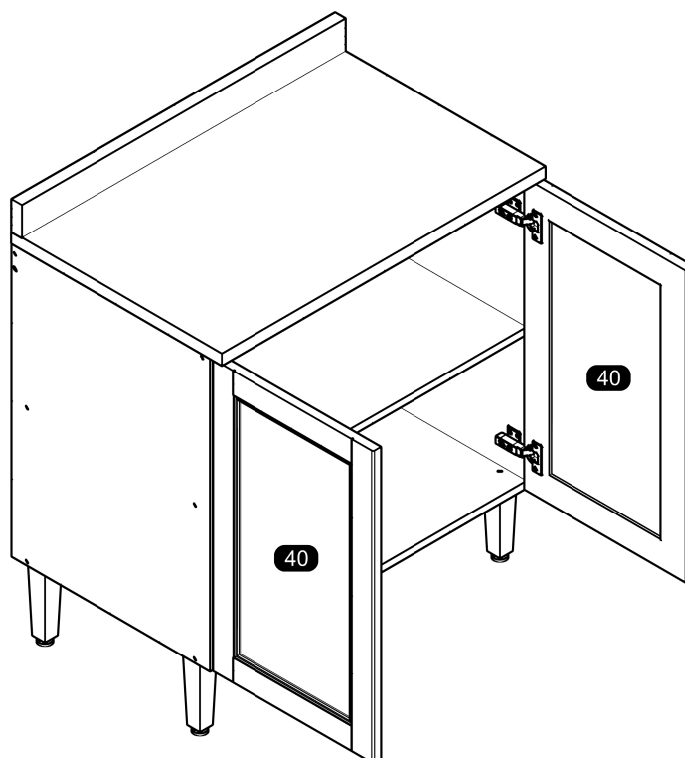
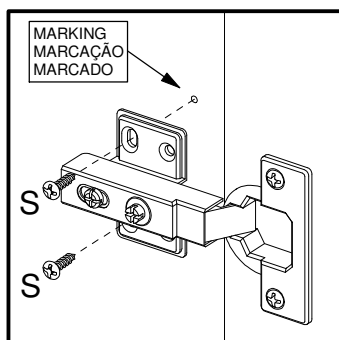

16

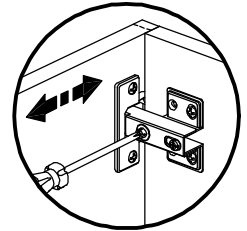
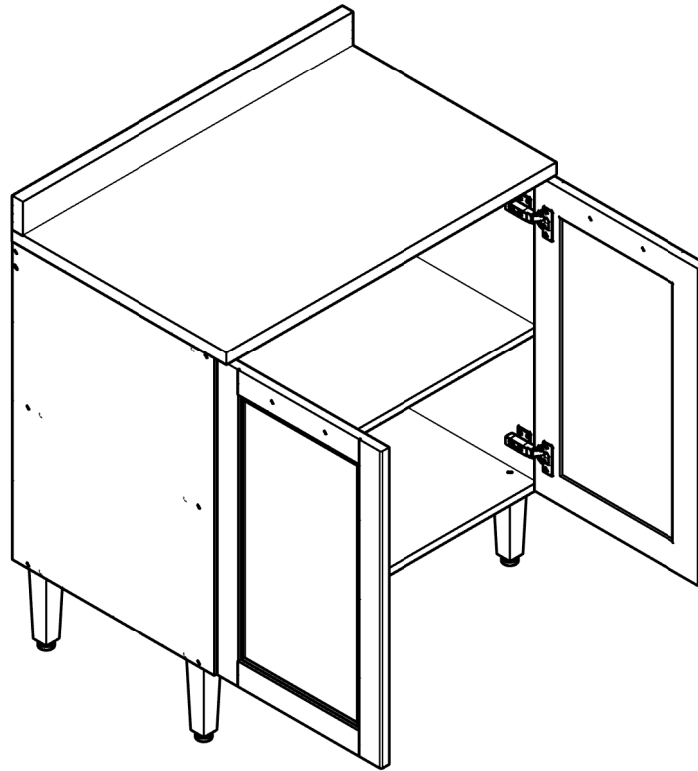

Horizontal Adjustment  
Regulagem Horizontal  
Ajuste Horizontal

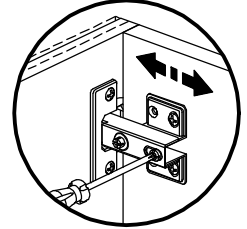

Depth Adjustment  
Regulagem Profundidade  
Ajuste Profundidade

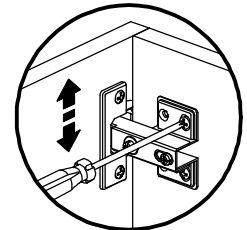

Vertical Adjustment  
Regulagem Vertical  
Ajuste Vertical

17

