

ASSEMBLY INSTRUCTIONS MANUAL DE MONTAGEM / INSTRUCCIONES DE ARMADO

CANELONE BASE CABINET 2 DOORS 3 DRAWERS 47 1/4"

BALCÃO 2 PORTAS 3 GAVETAS 1200MM CANELONE

GABINETE 2 PUERTAS 3 CAJONES 1200MM CANELONE

Reference
Referência **220367**
Referencia

Revised
Revisão **00**
Revisión



ENGLISH
PORTUGUÊS
ESPAÑOL

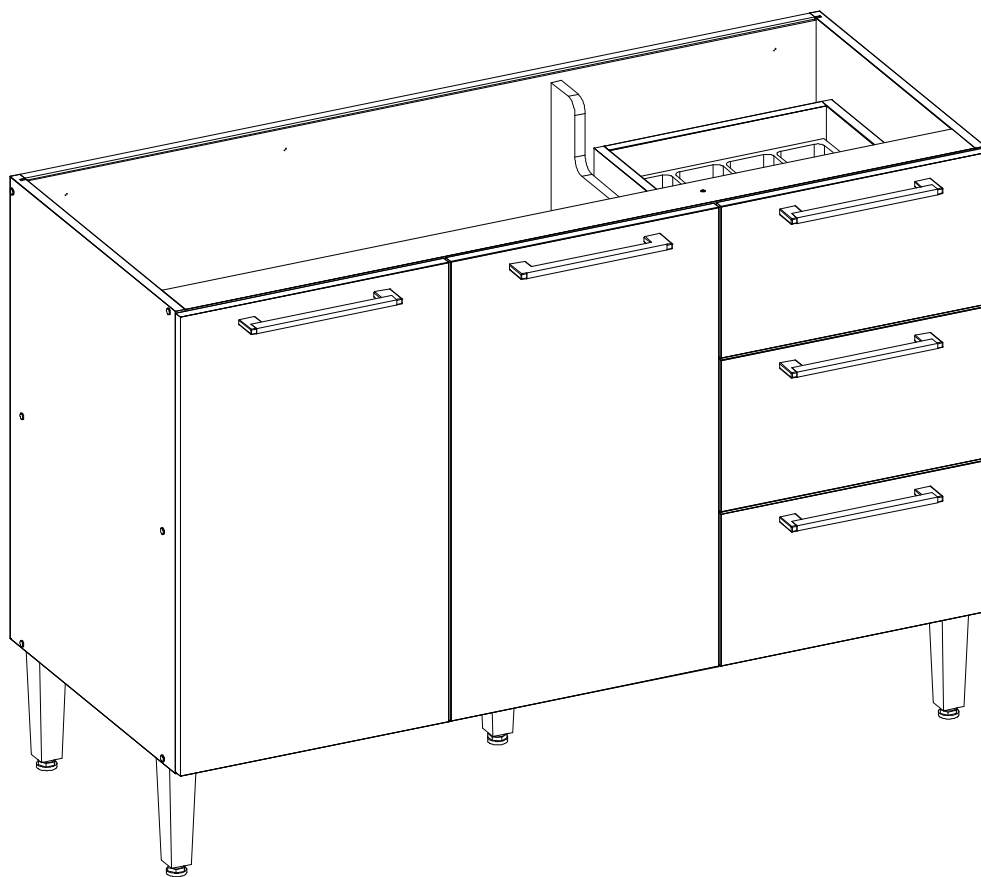

MAXIMUM RECOMMENDED WEIGHT
BEING THIS EVENLY DISTRIBUTED.

PESO MÁXIMO RECOMENDADO SENDO
ESTE DISTRIBUÍDO UNIFORMEMENTE.

PESO MÁXIMO RECOMENDADO SIENDO
ESTE UNIFORMEMENTE DISTRIBUIDO.

	LB	KG
–		
D	11	5
F	22	10

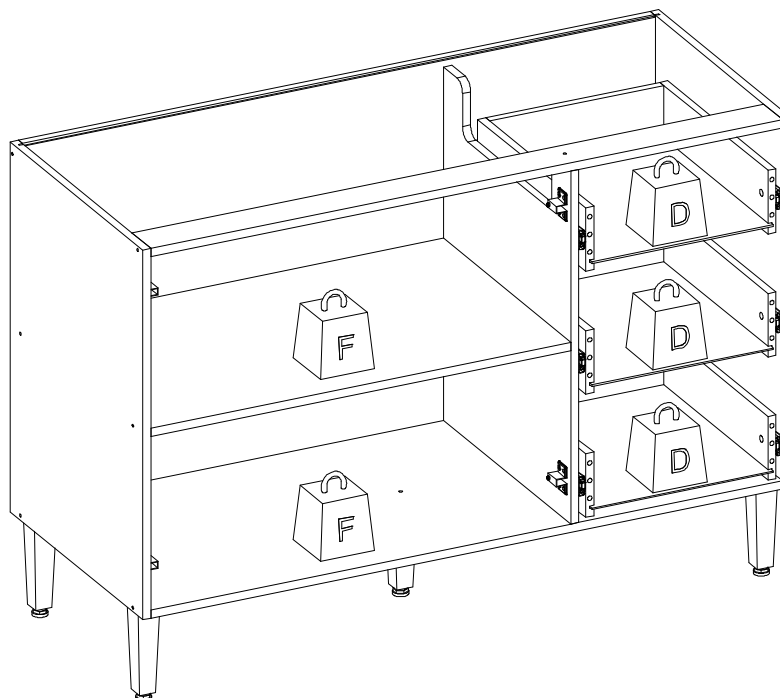

Nº	Measures_Inches	Medidas_cm	Qty./Qtd.
01	46 x 2 3/4 x 5/8	116.9 x 7.0 x 1.5	1
02	46 x 2 3/8 x 5/8	116.9 x 6.0 x 1.5	1
03	30 5/8 x 18 1/2 x 5/8	77.7 x 47.1 x 1.5	1
04	26 3/8 x 19 1/4 x 5/8	67.0 x 49.0 x 1.5	1
05	46 x 19 1/4 x 5/8	116.9 x 49.0 x 1.5	1
06	25 1/4 x 18 1/2 x 5/8	64.0 x 47.1 x 1.5	1
07	26 3/8 x 19 1/4 x 5/8	67.0 x 49.0 x 1.5	1
08	12 5/8 x 4 1/2 x 5/8	32.2 x 11.5 x 1.5	3
09	15 3/4 x 13 1/4 x 1/8	39.9 x 33.6 x 0.3	3
10	46 5/8 x 13 x 1/8	118.3 x 32.9 x 0.3	2
11	26 1/4 x 15 5/8 x 5/8	66.6 x 39.7 x 1.5	1
12	26 1/4 x 15 5/8 x 5/8	66.6 x 39.7 x 1.5	1
13	8 5/8 x 15 5/8 x 5/8	22.0 x 39.7 x 1.5	3
88	15 3/4 x 4 1/2 x 5/8	40.0 x 11.5 x 1.5	3
89	15 3/4 x 4 1/2 x 5/8	40.0 x 11.5 x 1.5	3

PARTS IDENTIFICATION IDENTIFICAÇÃO DAS PEÇAS / IDENTIFICACIÓN DE LAS PIEZAS

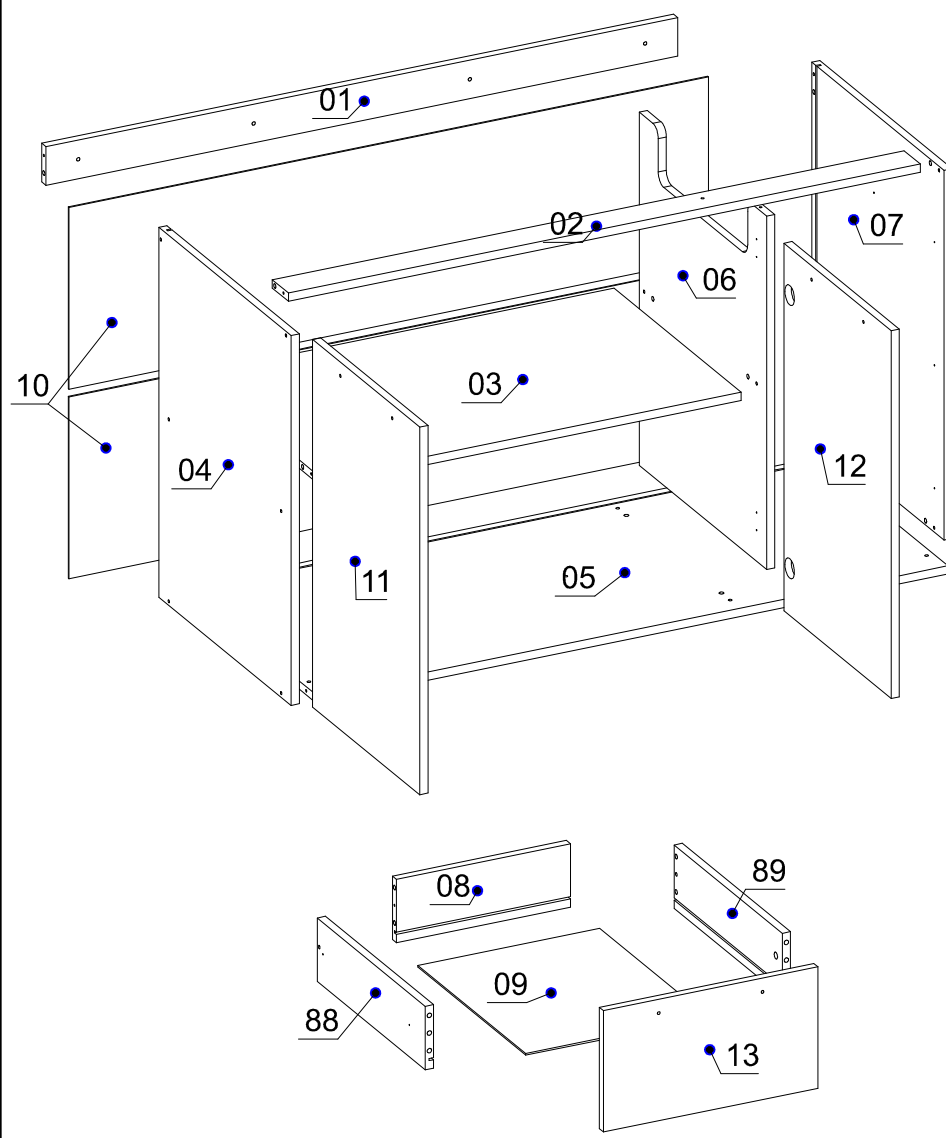

YOU WILL NEED / VOCÊ VAI PRECISAR DE / USTED NECESITARÁ

Tools not supplied / Ferramentas não fornecidas / Herramientas no incluidas

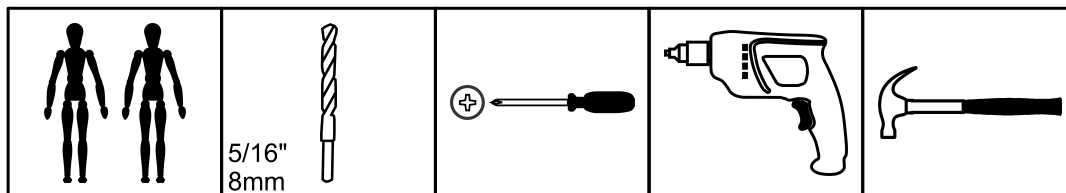

2 People
2 Pessoas
2 Personas

5/16"
8mm
Drill bit
Broca
Taladro

Screwdriver Phillips
Chave Phillips
Destornillador cruz

Drill machine
Furadeira
Taladro

Hammer
Martelo
Martillo











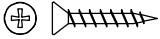
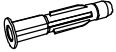
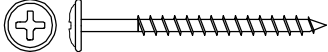

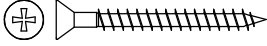
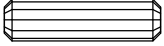
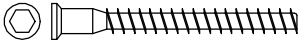

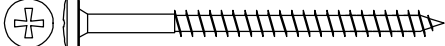
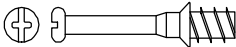

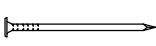

The separation of the accessories before you start the assembly will facilitate the same. In case of doubt on the size of the screws and bolts, use the ruler to bottom of page 3.

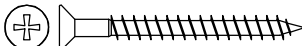
A separação dos acessórios antes de iniciar a montagem facilitará a mesma. Em caso de dúvida no tamanho dos parafusos e cavilhas, utilize a régua ao final da página 3.

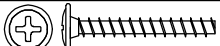
La separación de los accesorios antes de comenzar el armado facilitará el mismo. En caso de duda sobre el tamaño de los tornillos y taquetes, utilice la regla al pie de página 3.

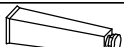
IDENTIFICATION OF ACCESSORIES IDENTIFICAÇÃO DOS ACESSÓRIOS/ IDENTIFICACIÓN DE ACCESORIOS

A1		Glue / Cola / Pegamento	13 g	1
A8		Flat head screw / Parafuso chato / Tornillo de cabeza plana	3,5x20 mm	6
B3		Bushing / Bucha expansiva / Tapón	8x50 mm	3
C		Flanged head screw / Parafuso flangeado / Tornillo de cabeza flangeada	4,5x45 mm	5
C1		Metal claw / Garra de metal / Garra metal	-	5
D		Flat head screw / Parafuso chato / Tornillo de cabeza plana	4,0x40 mm	1
E		Wooden dowel / Cavilha / Taquete	8x30 mm	38
G		Structural screw / Parafuso estrutural / Tornillo estructural	5,0x50 mm	13
H		Allen key / Chave allen / Liave allen	3 mm	1
I		Structural screw cover/Tampa parafuso estrutural/Tapa tornillo estructural	-	10
i4		Pan head screw / Parafuso panela / Tornillo de pan	5,0x70 mm	3
J		Simple minifix screw / Haste minifix simples / Tornillo minifix simple	-	6
K11		Silicone stop / Batente de silicone / Tope de silicona	8 mm	5
L		Drum lock / Tambor minifix / Tambor minifix	12 mm	6
M		Bore patch adhesive / Tapa furo adesivo / Tapones adhesivo	-	6
M17		Metal hinge straight / Dobradiça reta / Bisagra recta	35 mm	2
N		Nail / Prego / Clavo	10x10	5
N17		Metal hinge straight / Dobradiça curva / Bisagra recta	35 mm	2
O		Flat head screw / Parafuso chato / Tornillo de cabeza plana	4,5x45 mm	8
o1		Triangular support / Suporte triangular / Soporte triangular	-	6
S		Pan head screw / Parafuso panela / Tornillo de pan	3,5x14 mm	48
T		Flanged head screw / Parafuso flangeado / Tornillo de cabeza flangeada	3,5x25 mm	10
T7		Cutlery divider / Divisor de Talheres / Divisor de cubiertos	384x314mm	1
V3		Telescopic slide / Corrediça telescópica / Corredera telescópica	400 mm	3
X15		Foot / Pé Cônico FP / Pie	170 mm	5
X19		Handle / Puxador Citrino / Tirador	192 mm	5
Z		Plastic hole plugs / Tapa furo plástico / Tapones plásticos	8 mm	2

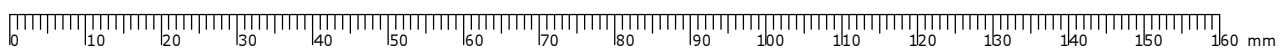

PRE-ASSEMBLE
PRÉ-MONTAGEM / PRE ARMADO

01

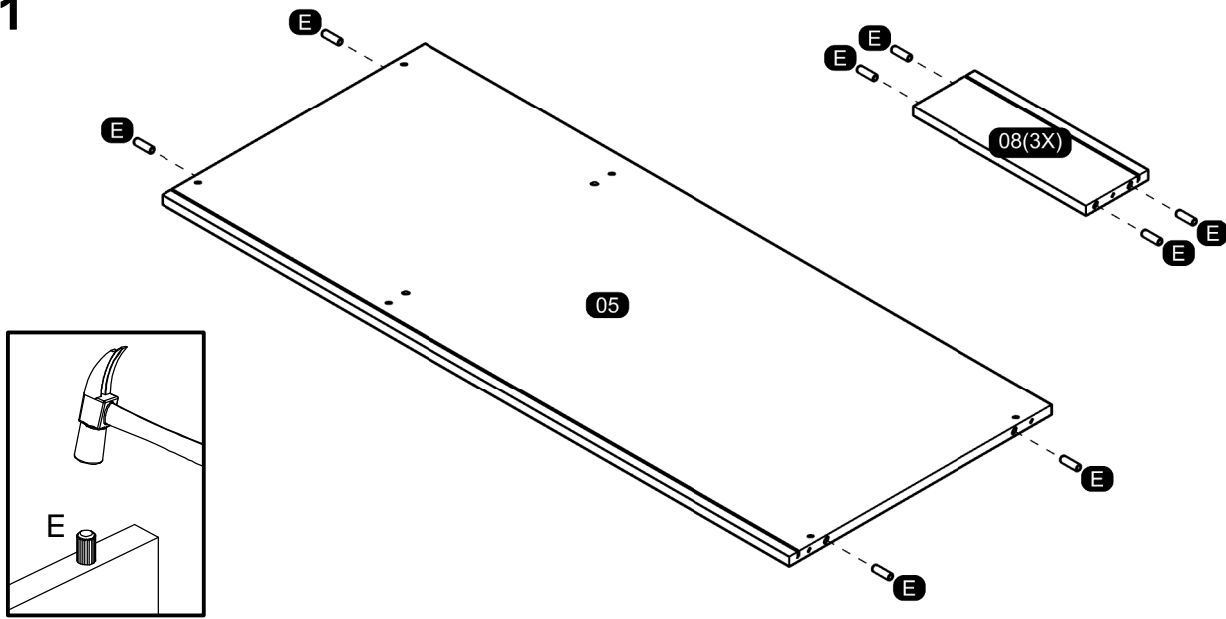

02

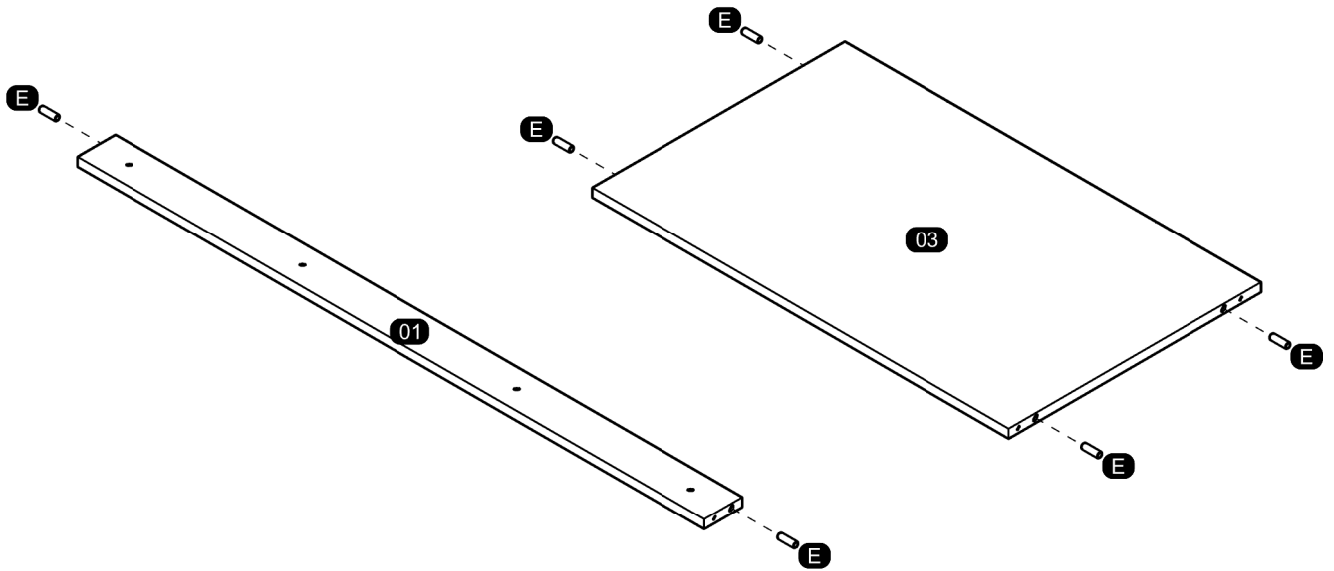

03

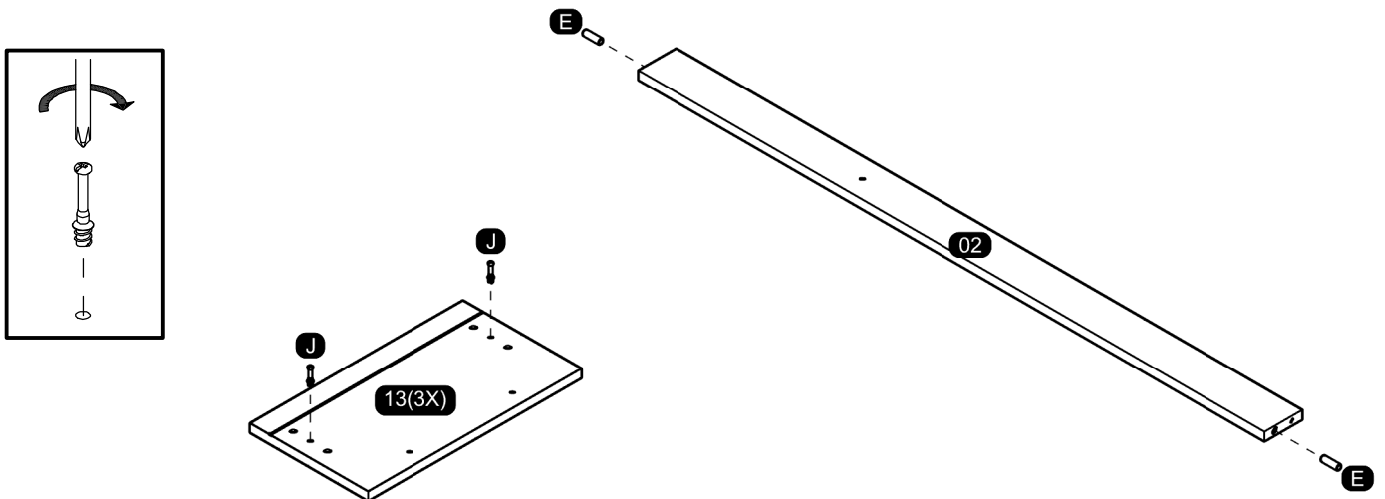

04

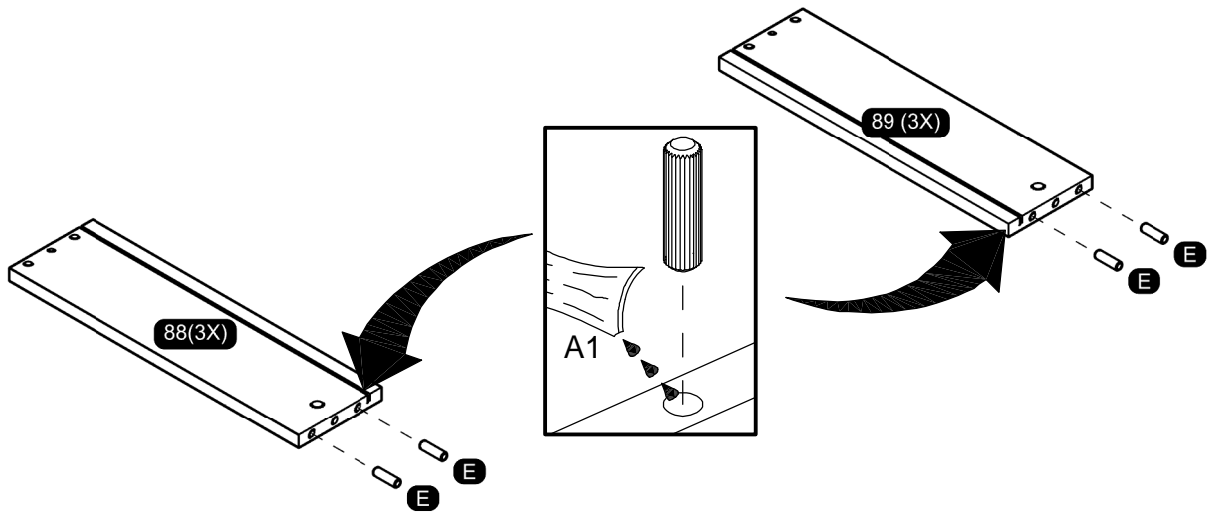

05

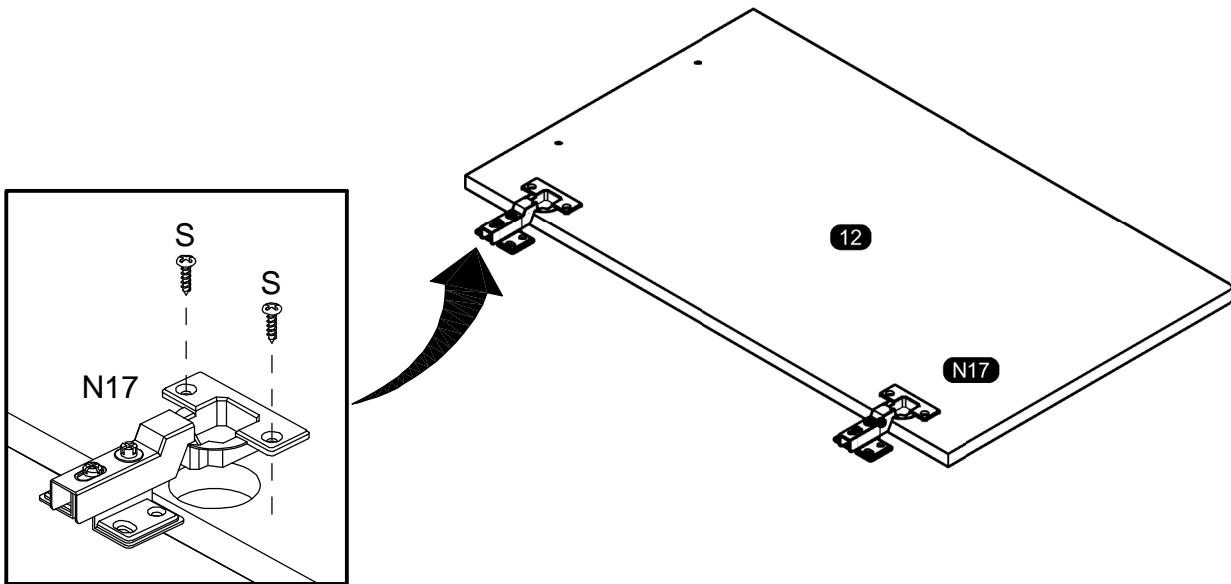

06

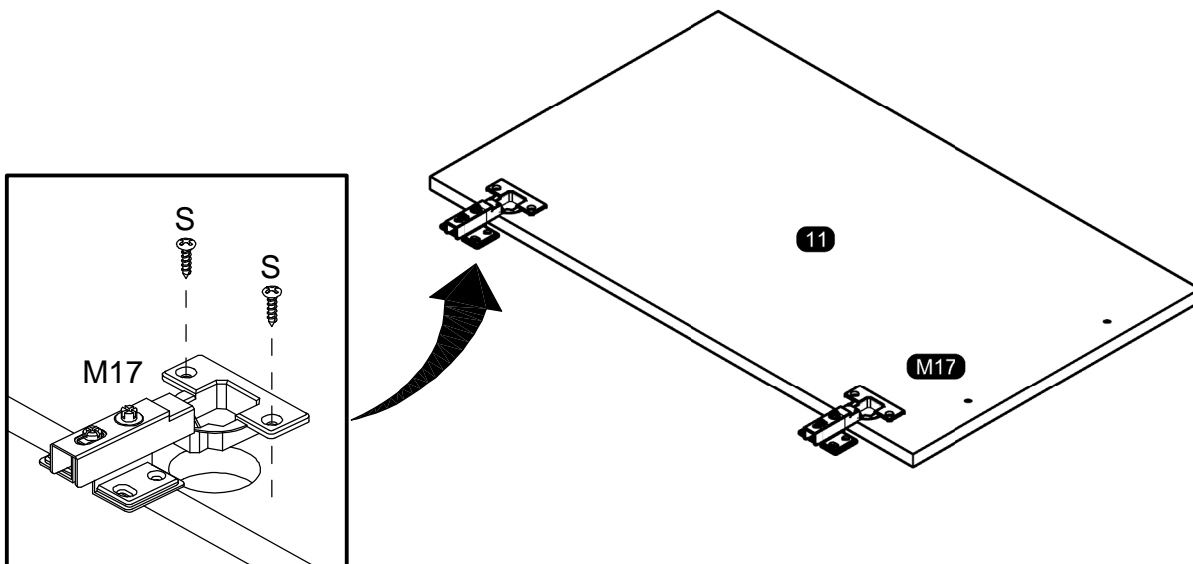

07

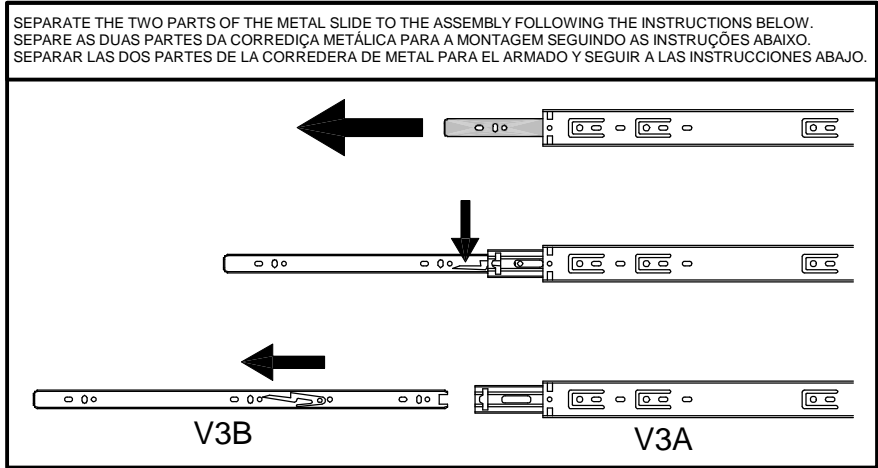

08

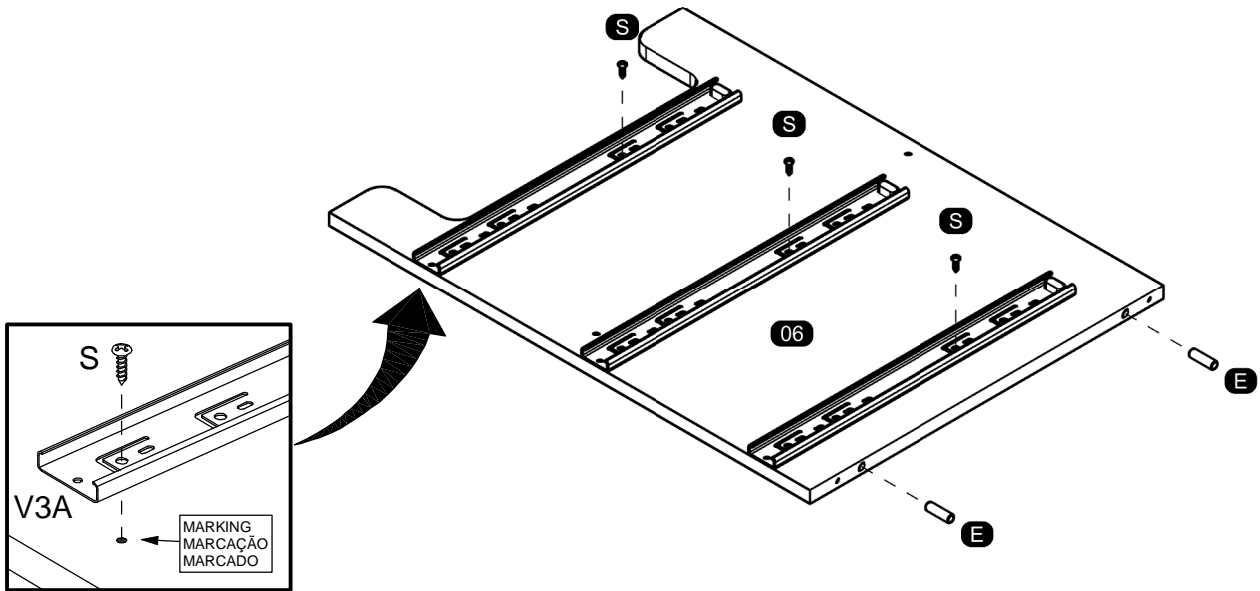

09

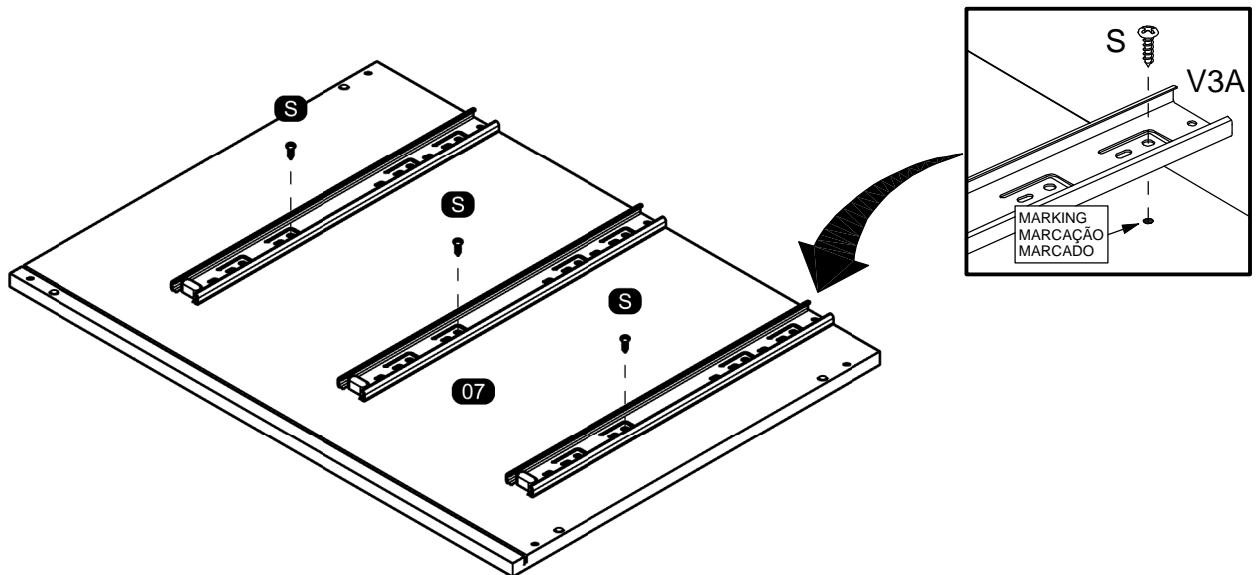

ASSEMBLY
MONTAGEM / ARMADO

10

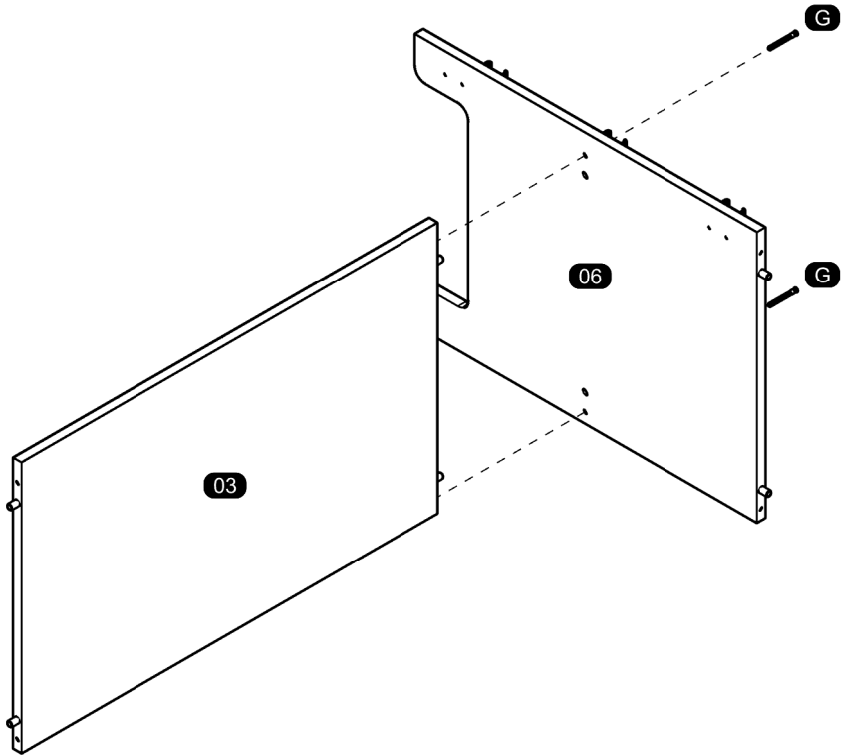
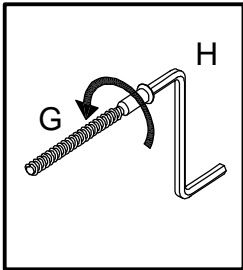

11

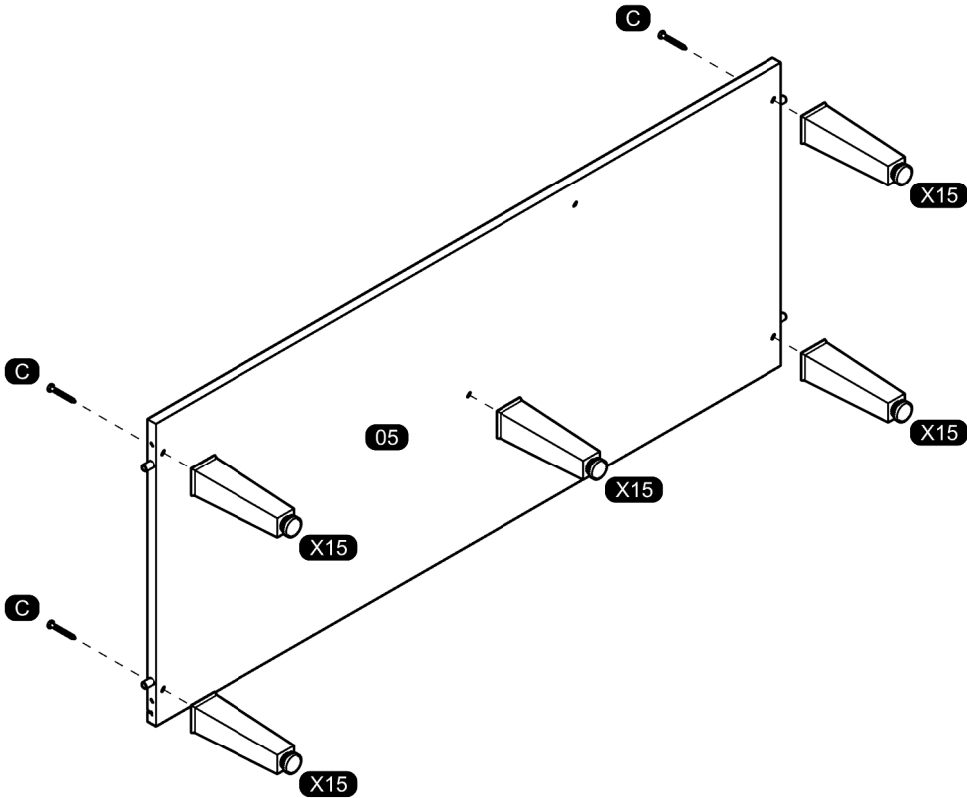

12

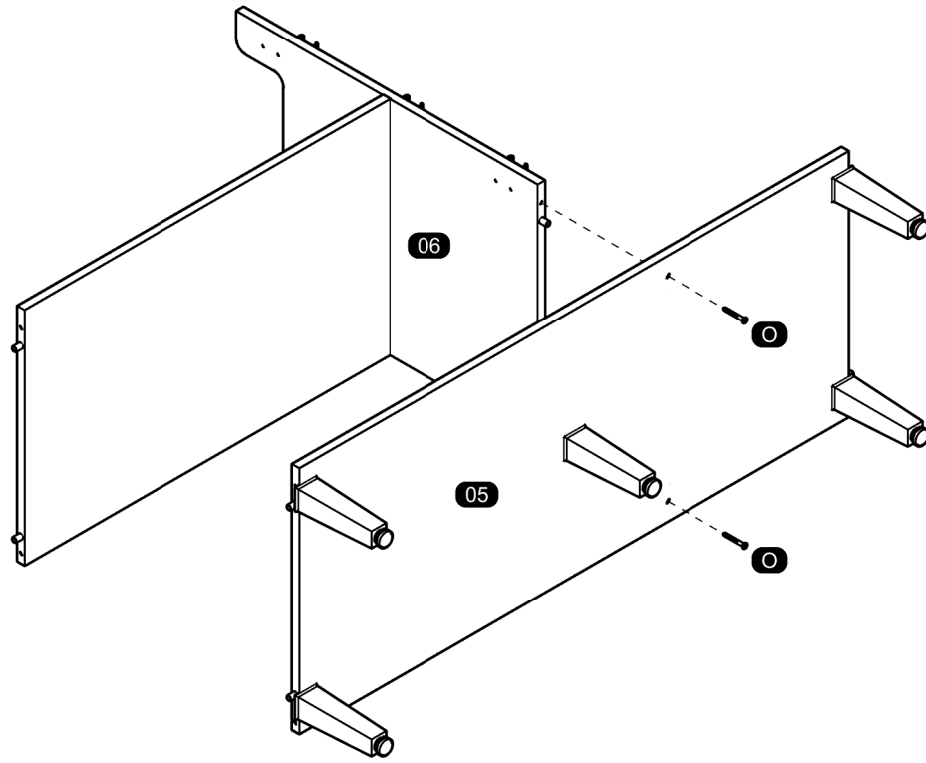

13

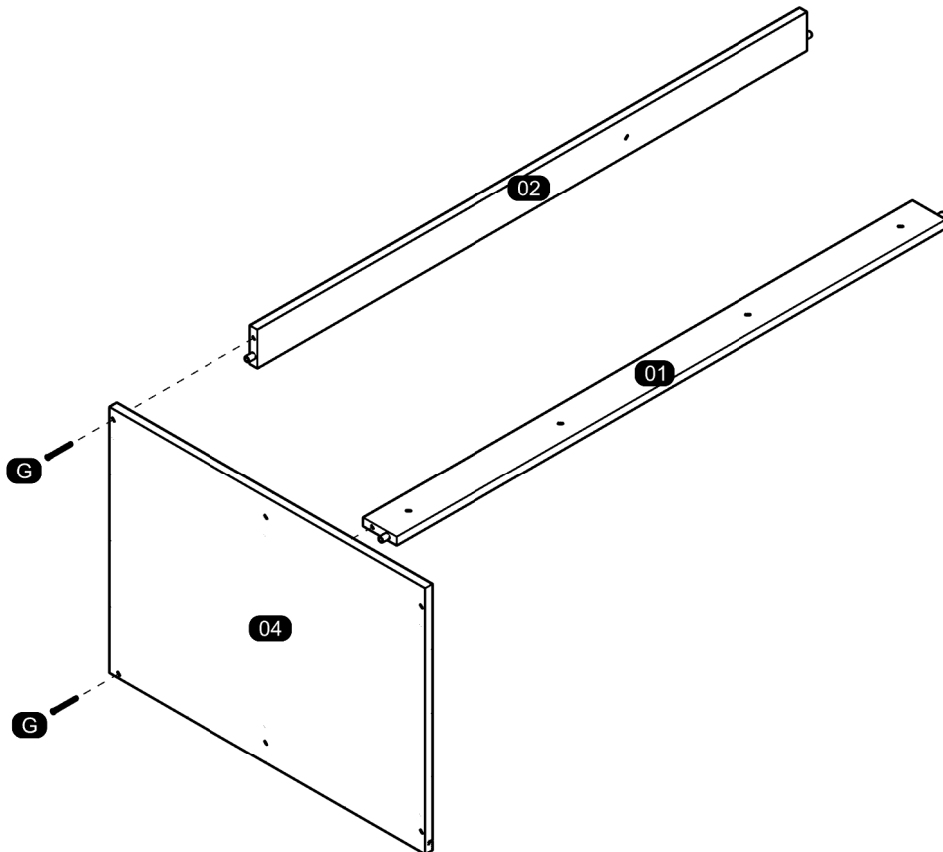

14

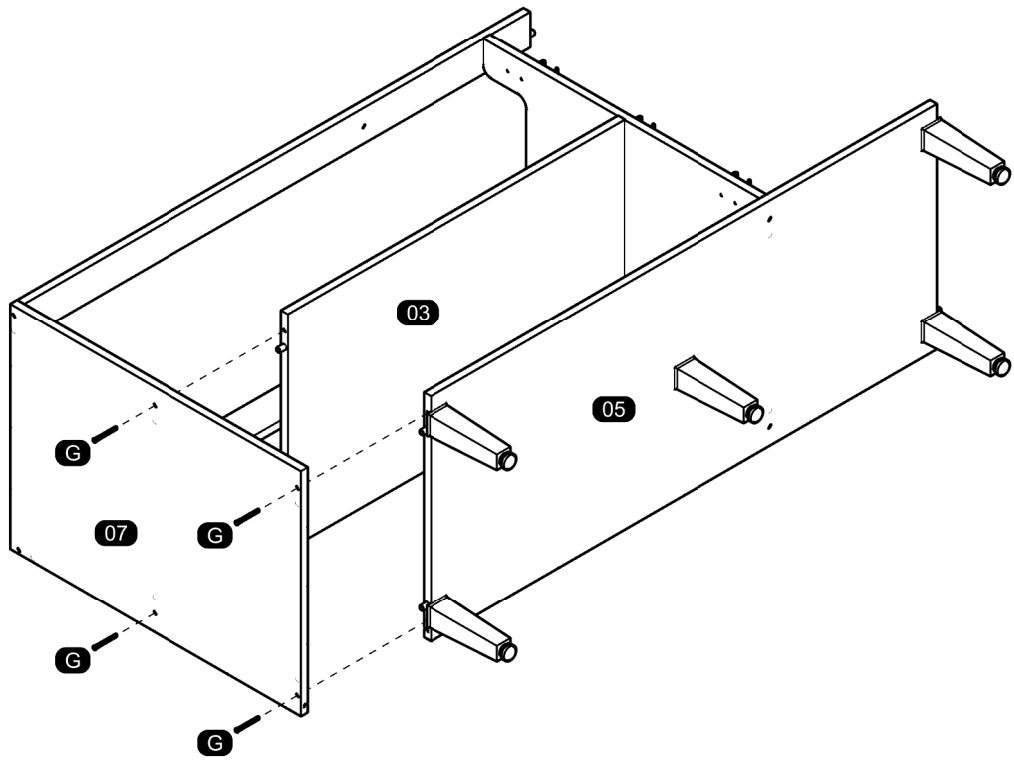

15

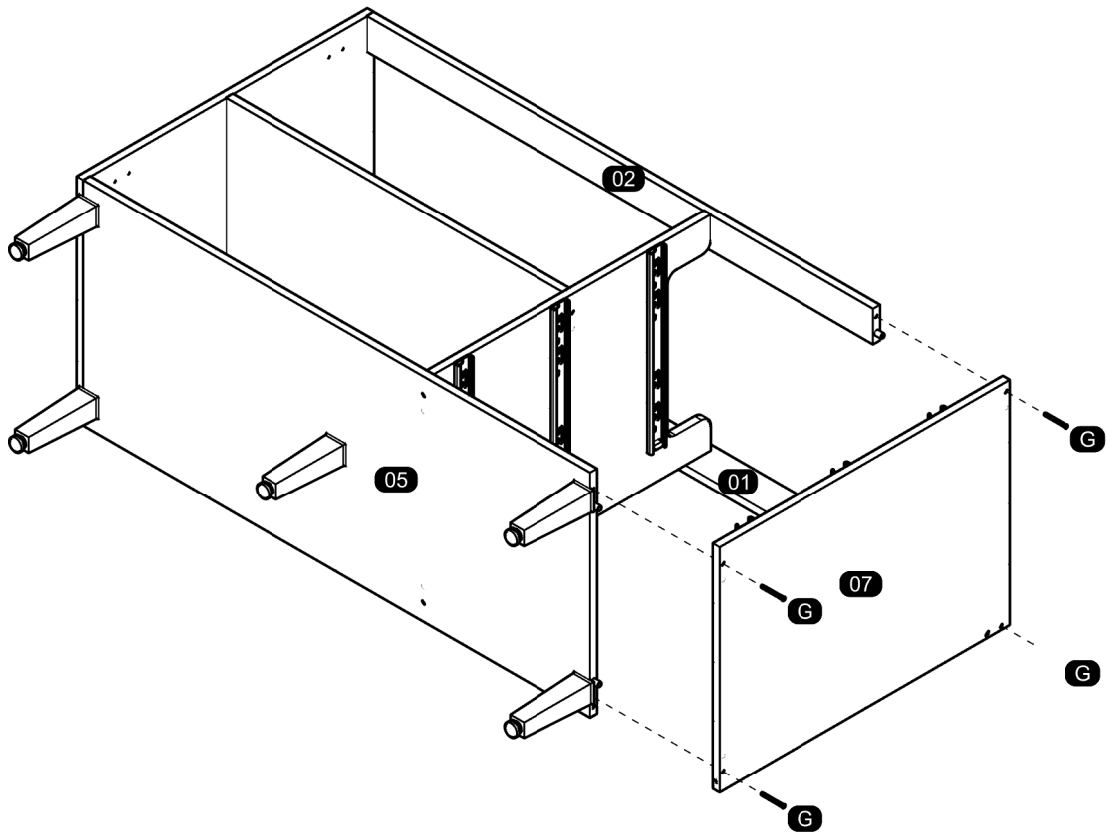

16

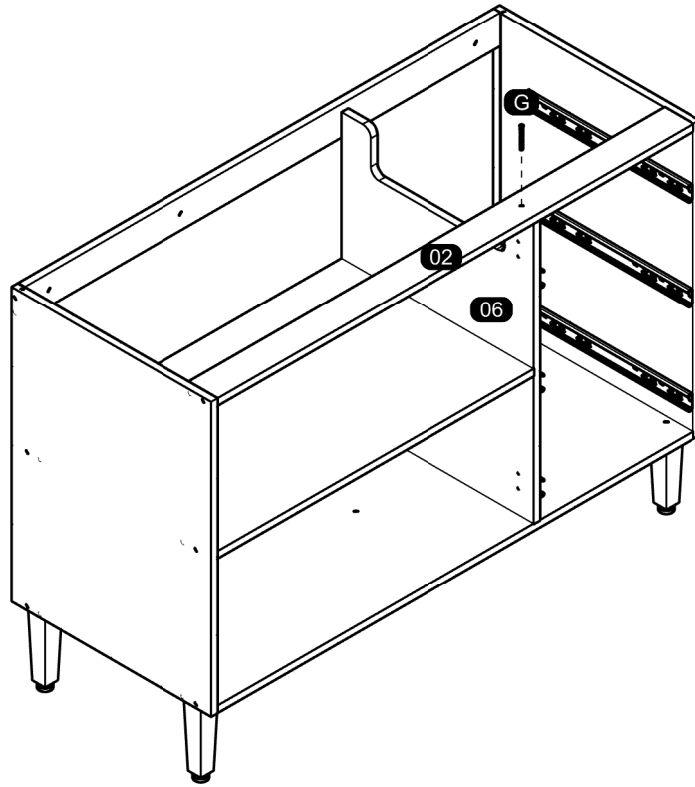

17

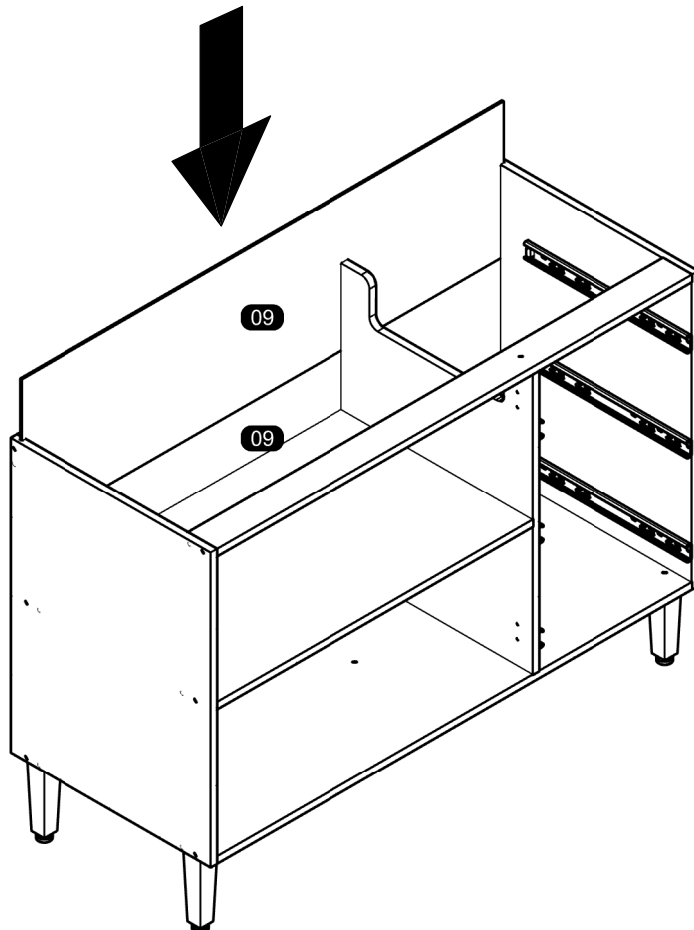
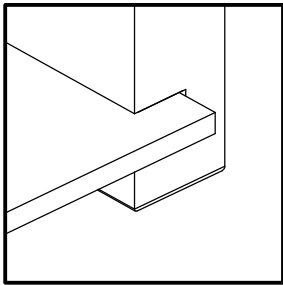

18

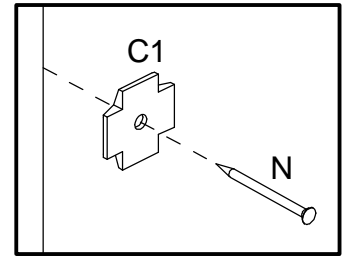
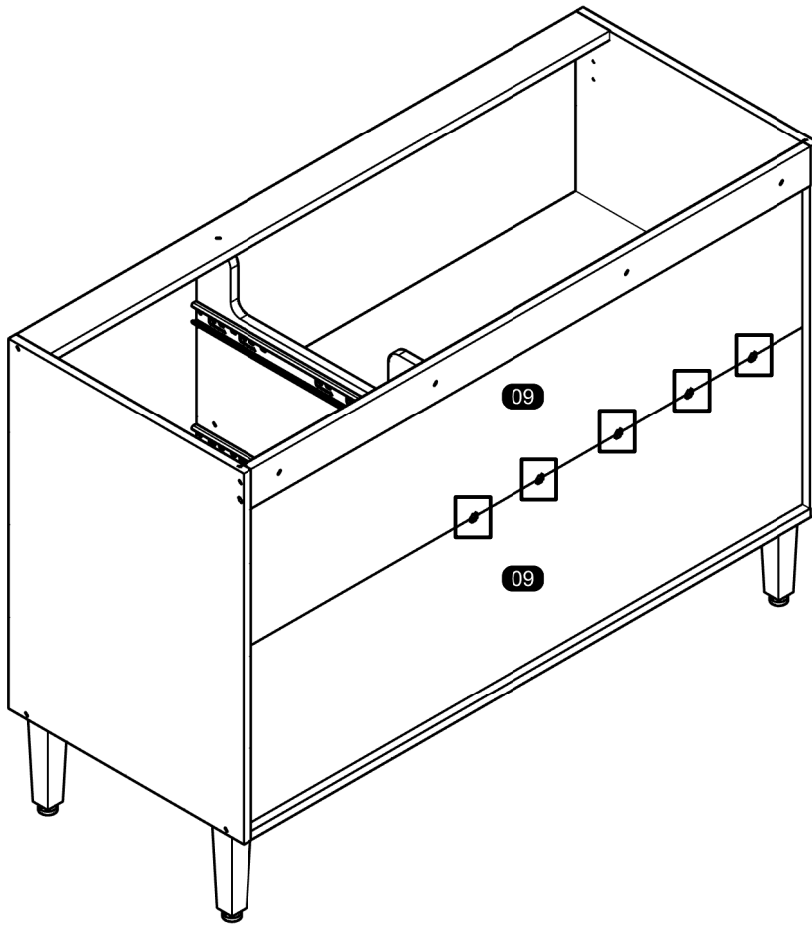

19

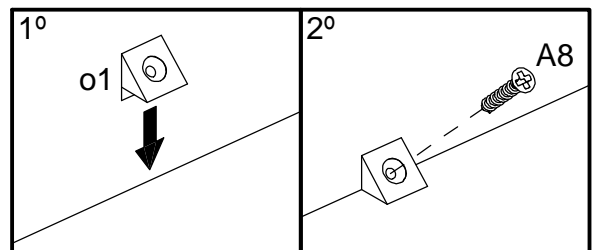
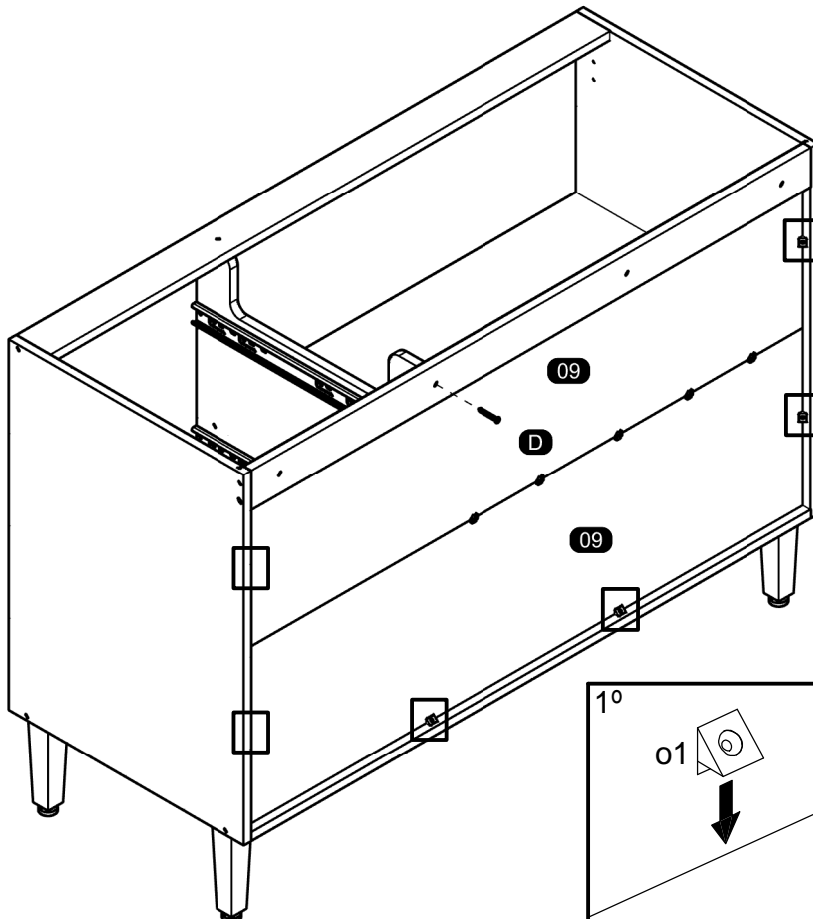

20

TO AVOID ANY INJURY THE FURNITURE MUST BE FIXED ON THE WALL. THANKS.
PARA EVITAR QUALQUER ACIDENTE, É OBRIGATÓRIO FIXAR O MÓVEL NA PAREDE. OBRIGADO!
PARA EVITAR CUALQUIER ACCIDENTE ES OBLIGATORIO ANCLAR EL MUEBLE EN LA PARED. GRACIAS.

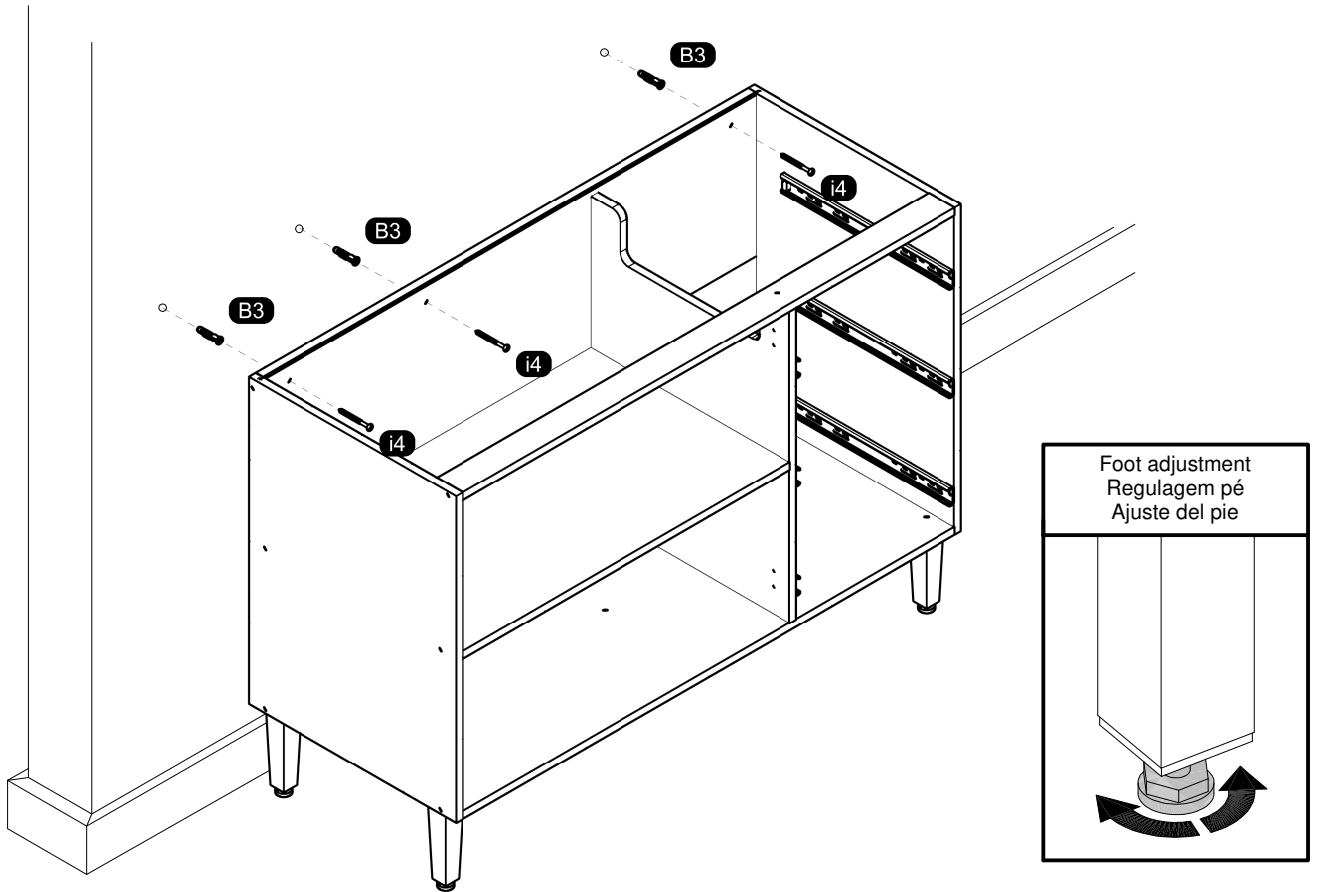

21

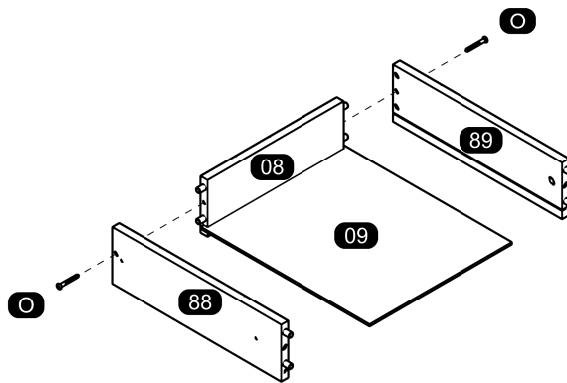

22

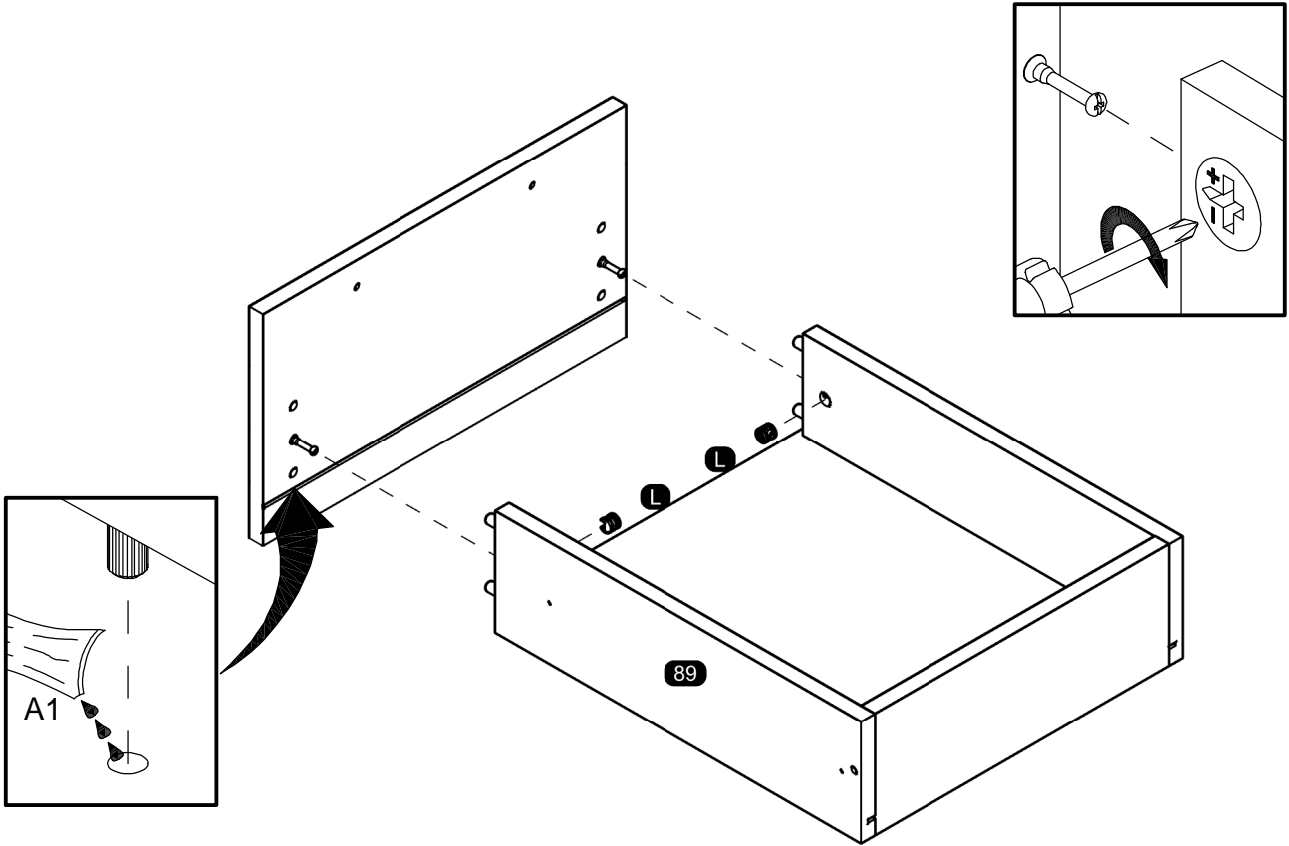

23

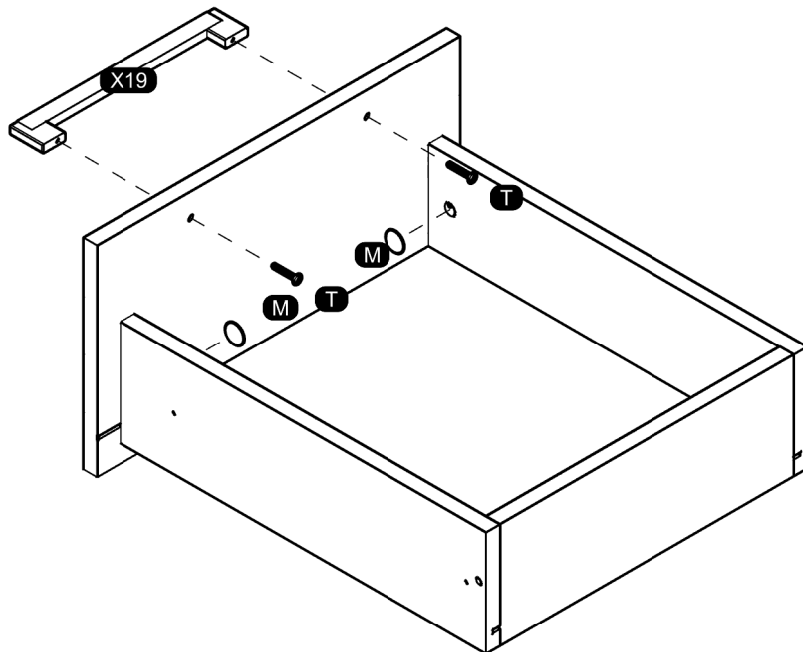

24

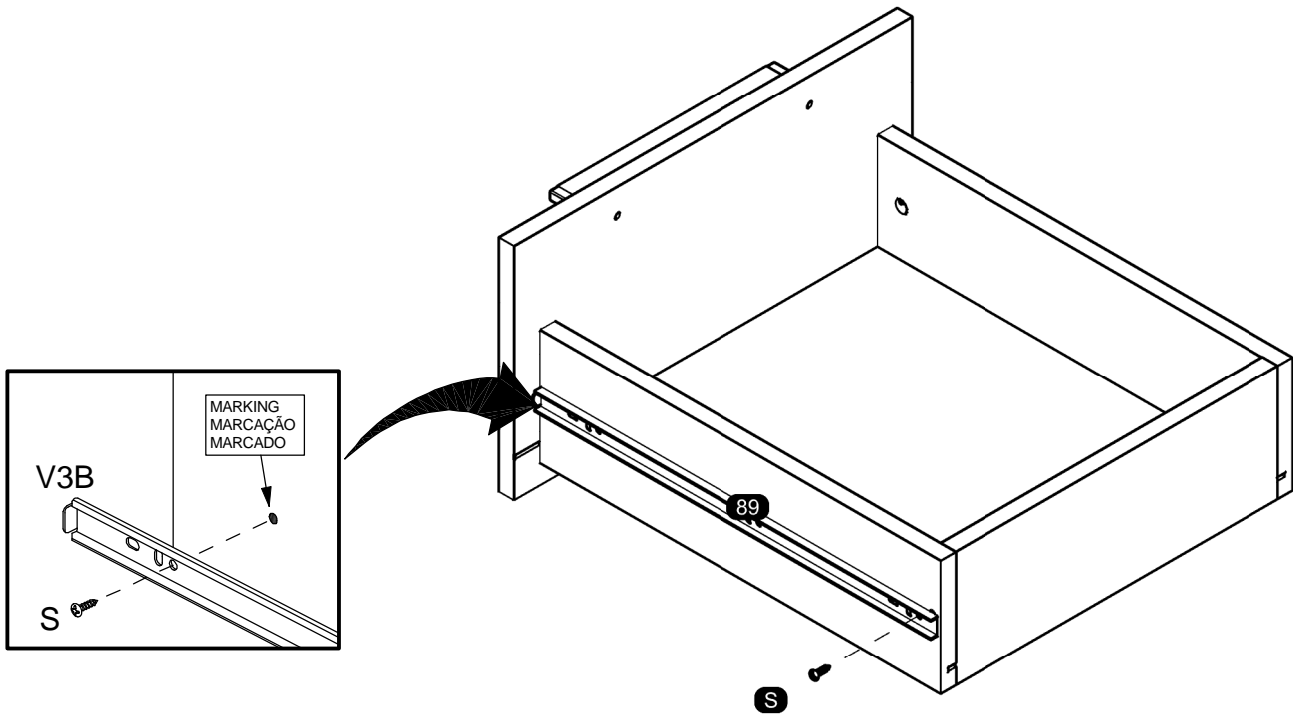

25

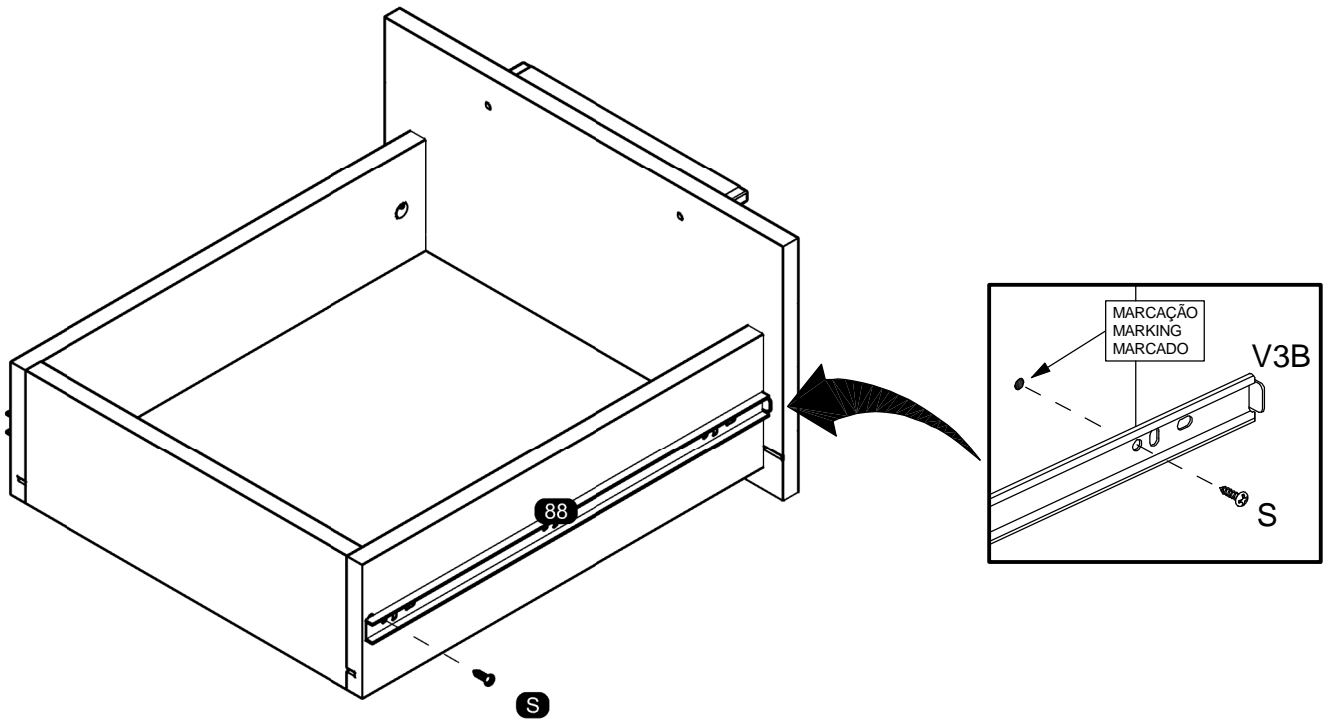

26

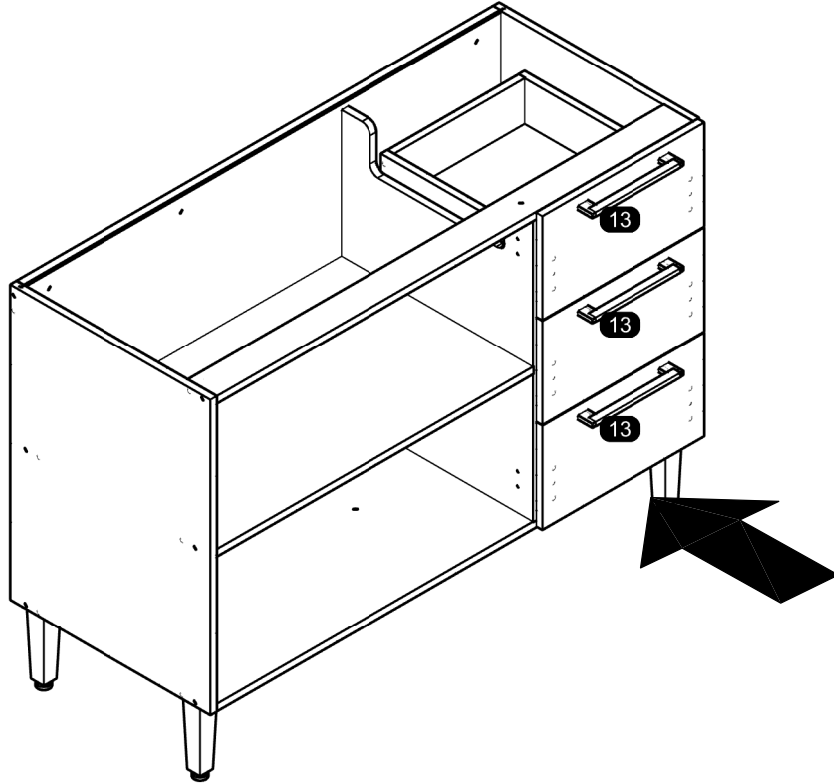

27

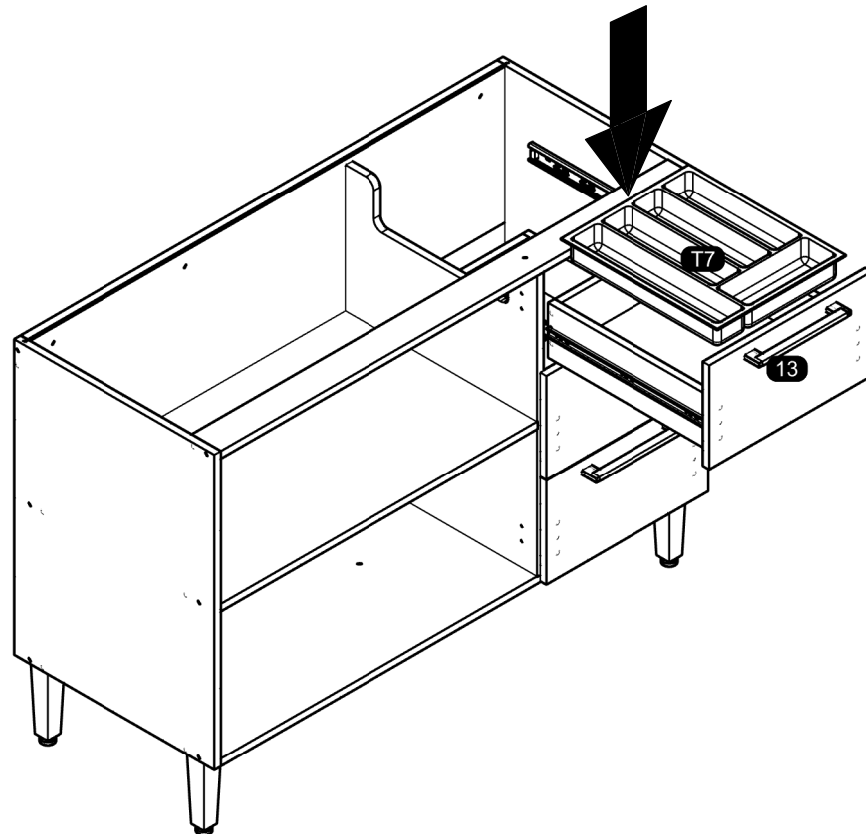

28

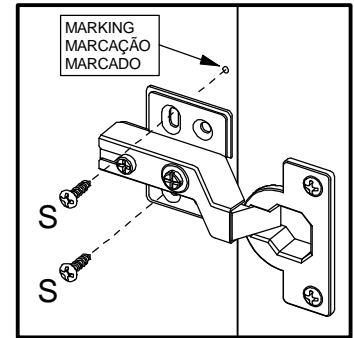
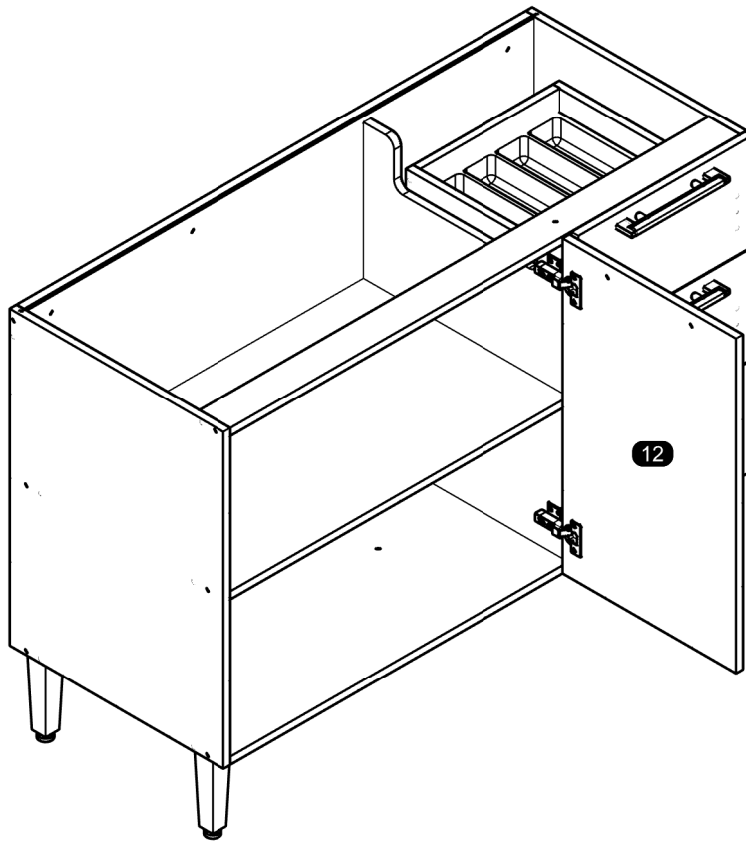

29

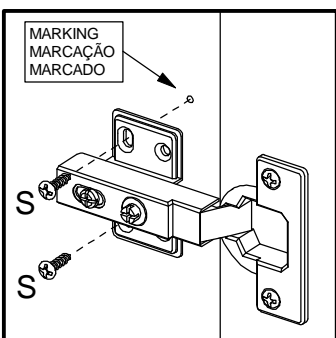
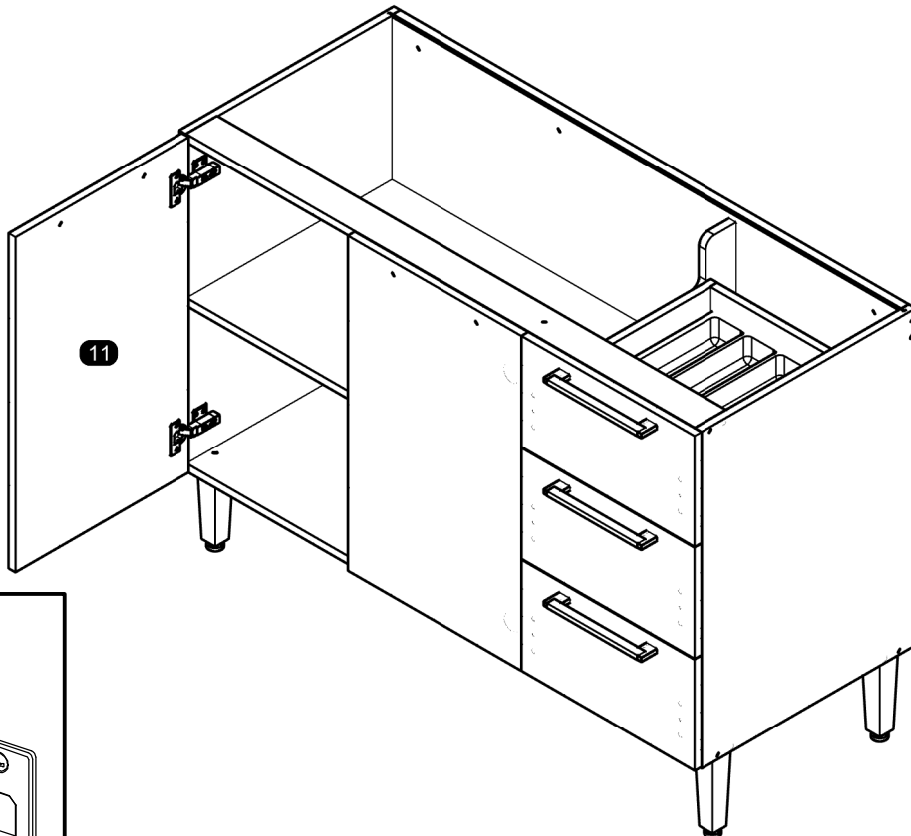

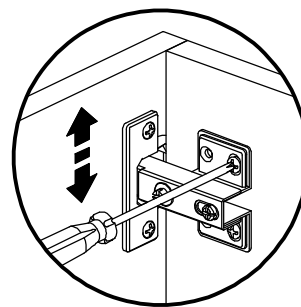
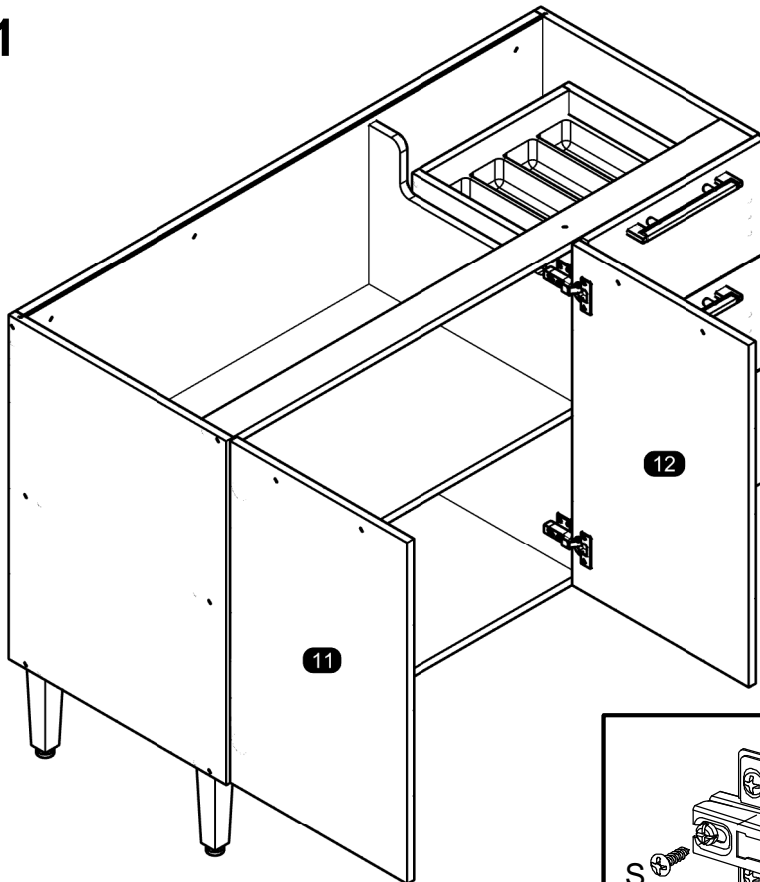
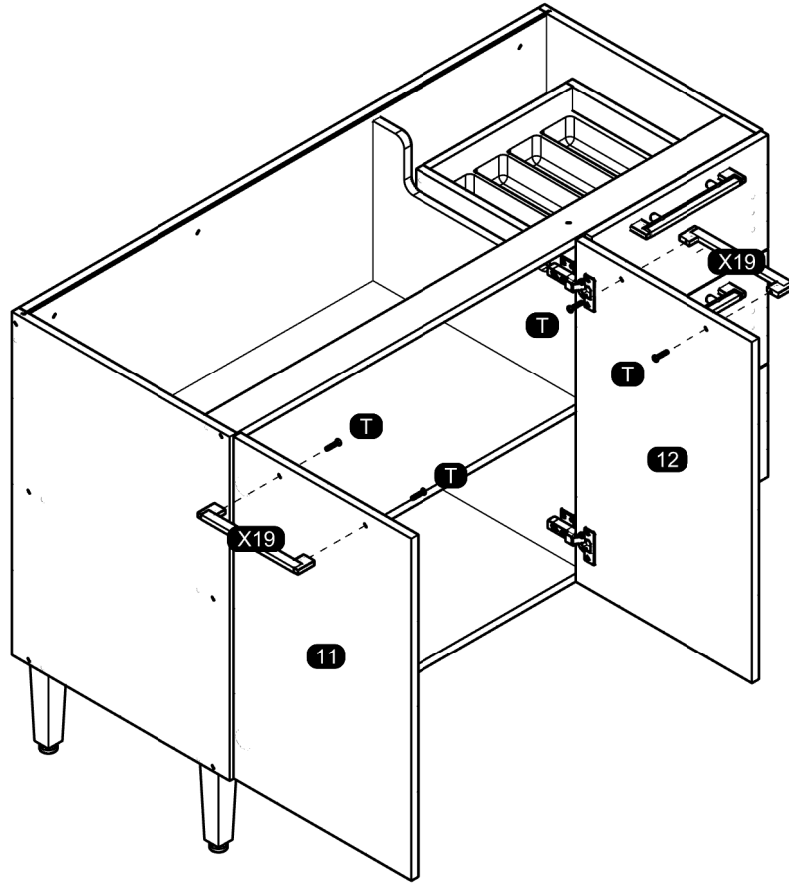

Vertical Adjustment
Regulagem Vertical
Ajuste Vertical

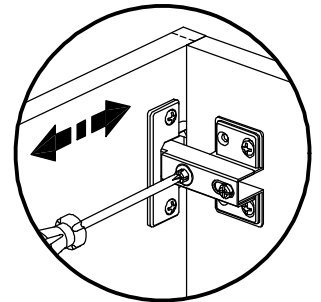

Horizontal Adjustment
Regulagem Horizontal
Ajuste Horizontal

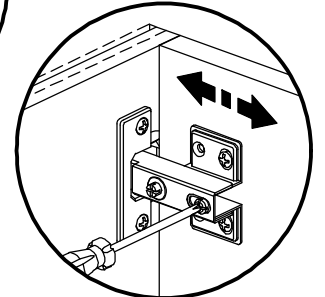

Depth Adjustment
Regulagem Profundidade
Ajuste Profundidade

