

# ASSEMBLY INSTRUCTIONS MANUAL DE MONTAGEM / INSTRUCCIONES DE ARMADO

CAMPANELE WALL CABINET 1 FLAP DOOR 30 3/16"  
AEREO 1 PORTA BASCULANTE 766MM CAMPANELE  
ARMARIO DE PARED 1 PUERTA HORIZONTAL 766 MM CAMPANELE

Reference 190381 | Revise 03  
Referência 190381 | Revisão 03  
Referencia 190381 | Revisión 03

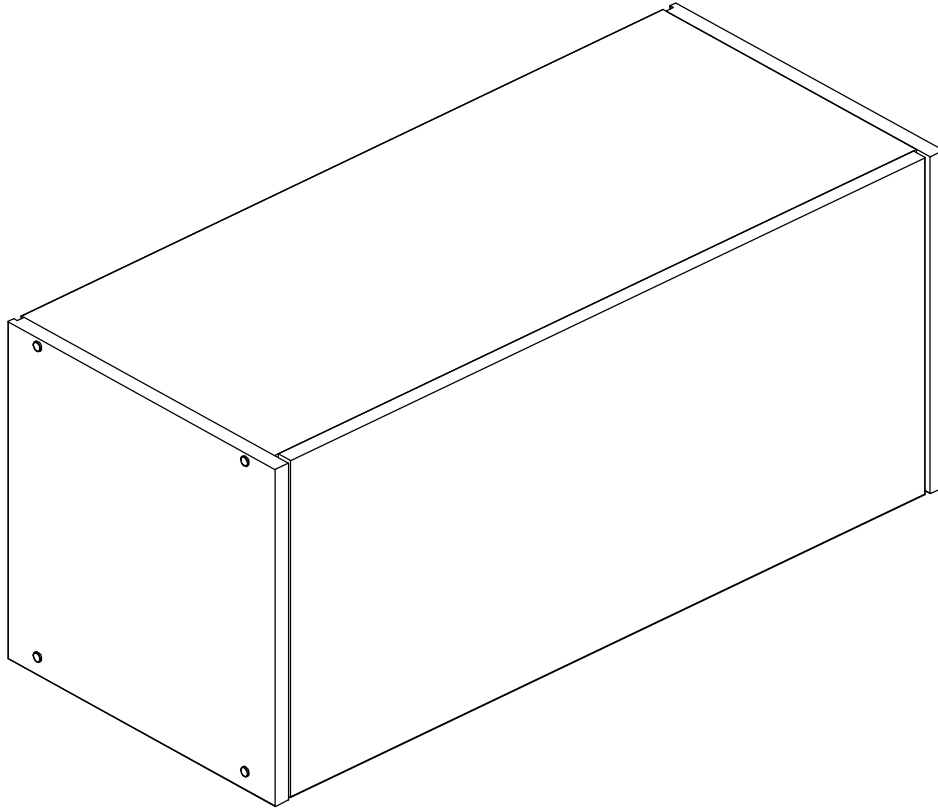

## YOU WILL NEED / VOCÊ VAI PRECISAR DE / USTED NECESITARÁ

### Tools not supplied / Ferramentas não fornecidas / Herramientas no incluidas

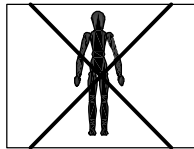

1 Person  
1 Pessoa  
1 Persona

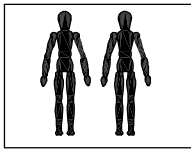

2 People  
2 Pessoas  
2 Personas

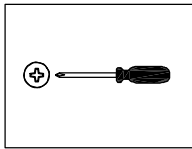

Screwdriver Phillips  
Chave Phillips  
Destornillador cruz

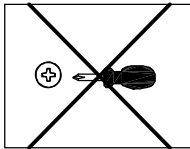

Small screwdriver Phillips  
Chave Phillips Menor  
Destornillador cruz menor

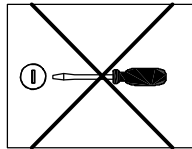

Screwdriver slotted  
Chave fenda  
Destornillador plano

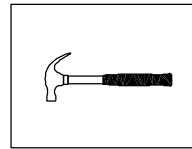

Hammer  
Martelo  
Martillo

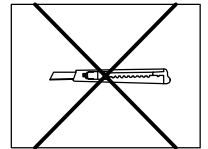

Stylet  
Estilete  
Estilete

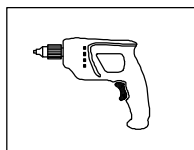

Drill machine  
Furadeira  
Taladro

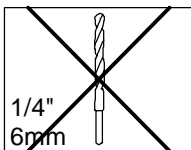

Drill bit  
Broca  
Taladro

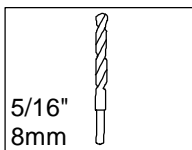

Drill bit  
Broca  
Taladro

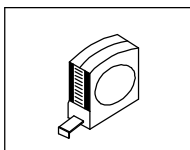

Measuring tape  
Trena  
Cinta de medición

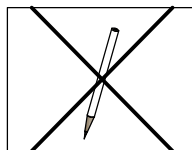

Pencil  
Lápis  
Lápis

**NOTES:** The separation of the accessories before you start the assembly will facilitate the same. In case of doubt on the size of the screws and bolts, use the ruler to bottom of page 3.

**NOTAS:** A separação dos acessórios antes de iniciar a montagem facilitará a mesma. Em caso de dúvida no tamanho dos parafusos e cavilhas, utilize a régua ao final da página 3.

**NOTAS:** La separación de los accesorios antes de comenzar el armado facilitará el mismo. En caso de duda sobre el tamaño de los tornillos y taquetes, utilice la regla al pie de página 3.

MAXIMUM RECOMMENDED WEIGHT  
BEING THIS EVENLY DISTRIBUTED

PESO MÁXIMO RECOMENDADO SENDO  
ESTE DISTRIBUÍDO UNIFORMEMENTE

PESO MÁXIMO RECOMENDADO SIENDO  
ESTE UNIFORMEMENTE DISTRIBUIDO

	LB	KG
<b>A</b>	22	10

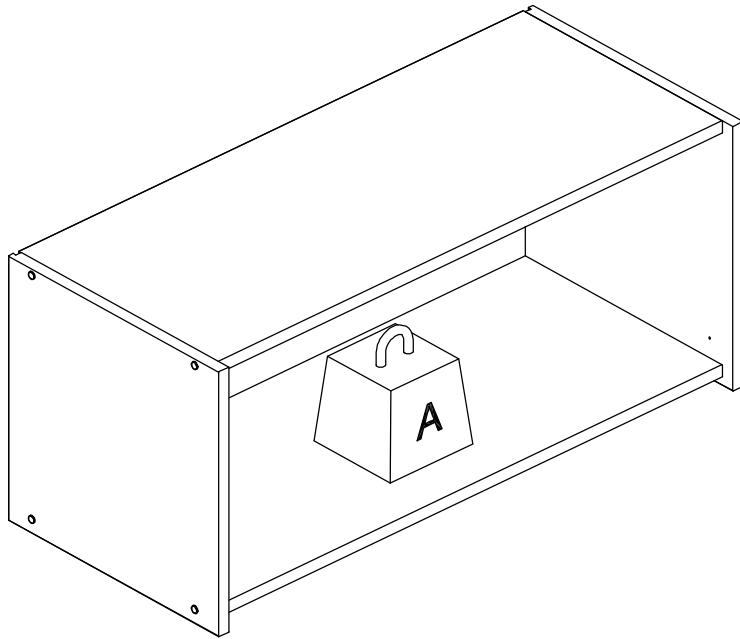





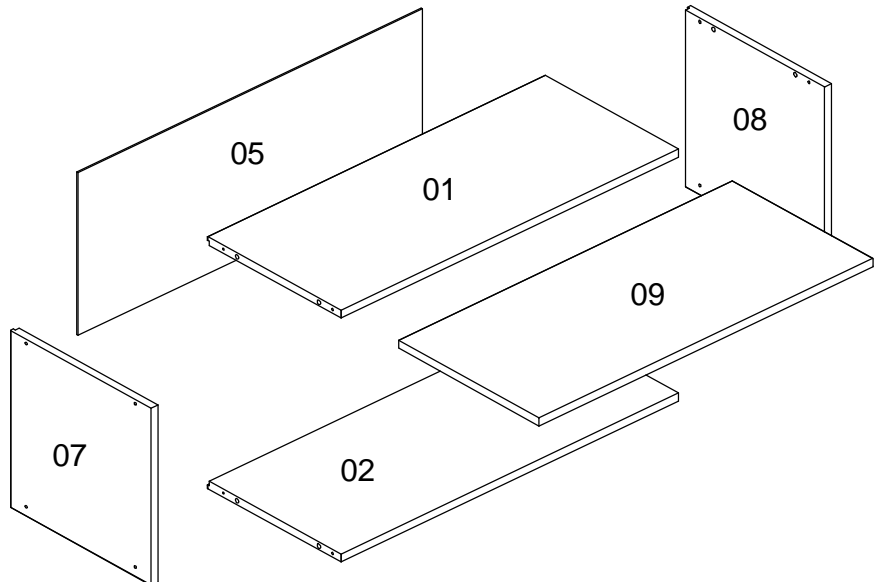



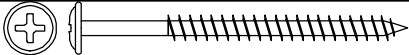
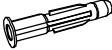

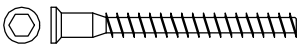

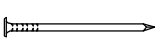
Nº	Measures Inches	Medidas cm	Qty./Qtd.
01	12 3/8 x 29 x 5/8	31,3 x 73,6 x 1,5	1
02	12 3/8 x 29 x 5/8	31,3 x 73,6 x 1,5	1
07	13 x 13 x 5/8	33 x 33 x 1,5	1
08	13 x 13 x 5/8	33 x 33 x 1,5	1
05	29 1/2 x 11 7/8 x 1/8	75 x 30,3 x 0,3	1
09	28 3/4 x 13 x 5/8	73 x 33 x 1,5	1

**PARTS IDENTIFICATION**  
**IDENTIFICAÇÃO DAS PEÇAS / IDENTIFICACIÓN DE LAS PIEZAS**

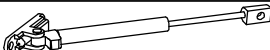

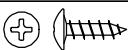
## IDENTIFICATION OF ACCESSORIES IDENTIFICAÇÃO DOS ACESSÓRIOS/ IDENTIFICACIÓN DE ACCESORIOS

A		Flanged head screw / Parafuso flangeado / Tornillo de cabeza flangeada	5,0x60 mm	2
B3		Bushing / Bucha expansiva / Tapón	8x50 mm	2
E		Wooden dowel / Cavilha / Taquete	8x30 mm	8
G		Structural screw / Parafuso estrutural / Tornillo estructural	5,0x50 mm	8
H		Allen key / Chave allen / Liave allen	3 mm	1
I		Structural screw cover/Tampa parafuso estrutural/Tapa tornillo estructural	-	8
N		Nail / Prego / Clavo	10x10	20
N5		Support "L" / Suporte "L" / Soporte "L"	-	2
N6		Cover / Capa / Cubierta	-	2
S		Pan head screw / Parafuso panela / Tornillo de pan	3,5x14 mm	16
X16A		Gas piston / Pistão a gás / Pistón de gas	-	1
X16B		Side support piston / Suporte pistão lateral / Soporte pistón lateral	-	1
X16C		Pan head screw / Parafuso panela / Tornillo de pan	3,5x14 mm	5
Z13		Metal hinge straight / Dobradiça reta / Bisagra recta	35 mm	2



PRE-ASSEMBLE  
PRÉ-MONTAGEM / PRE ARMADO

01

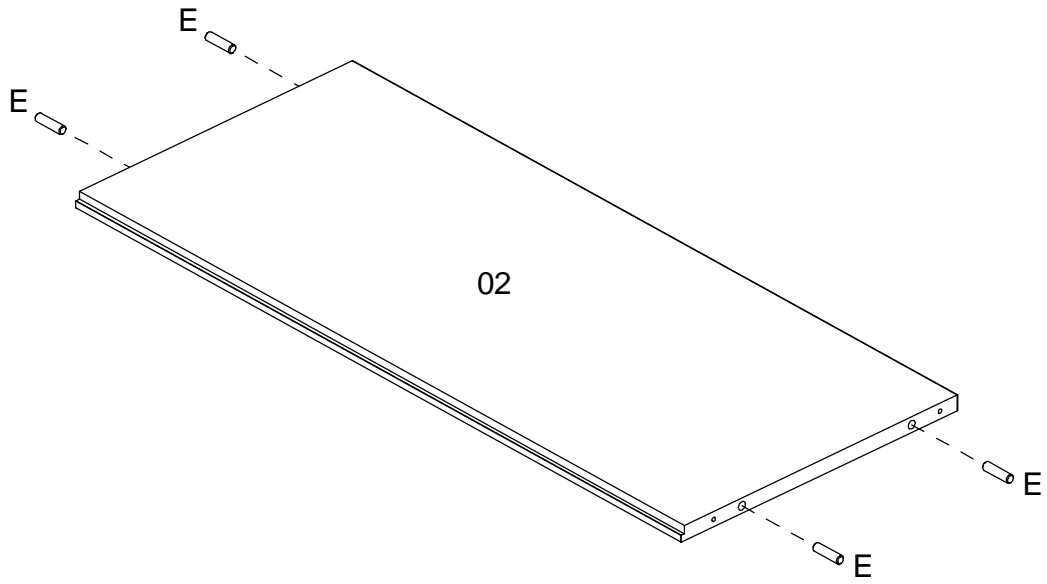
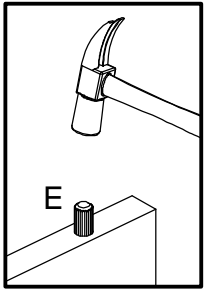

02

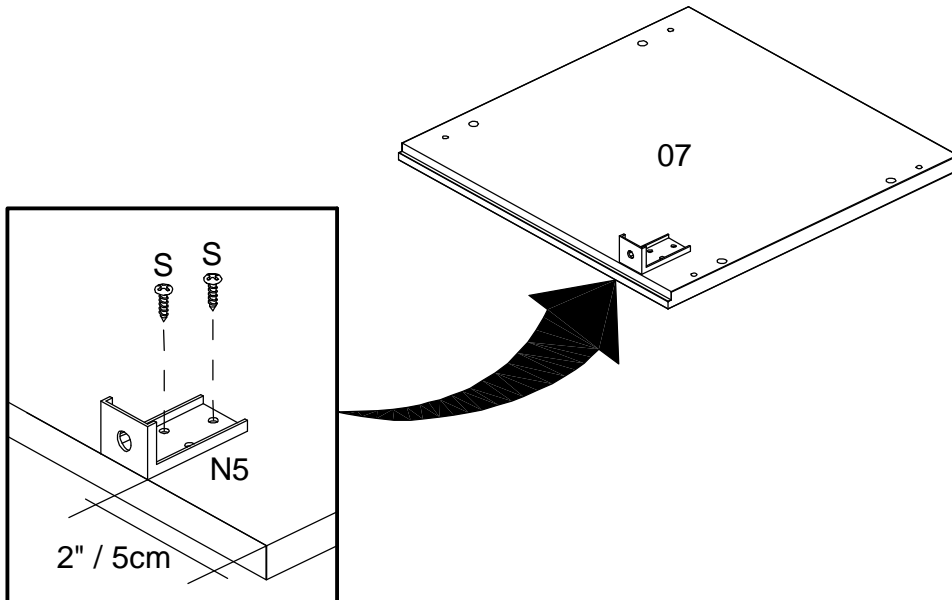

03

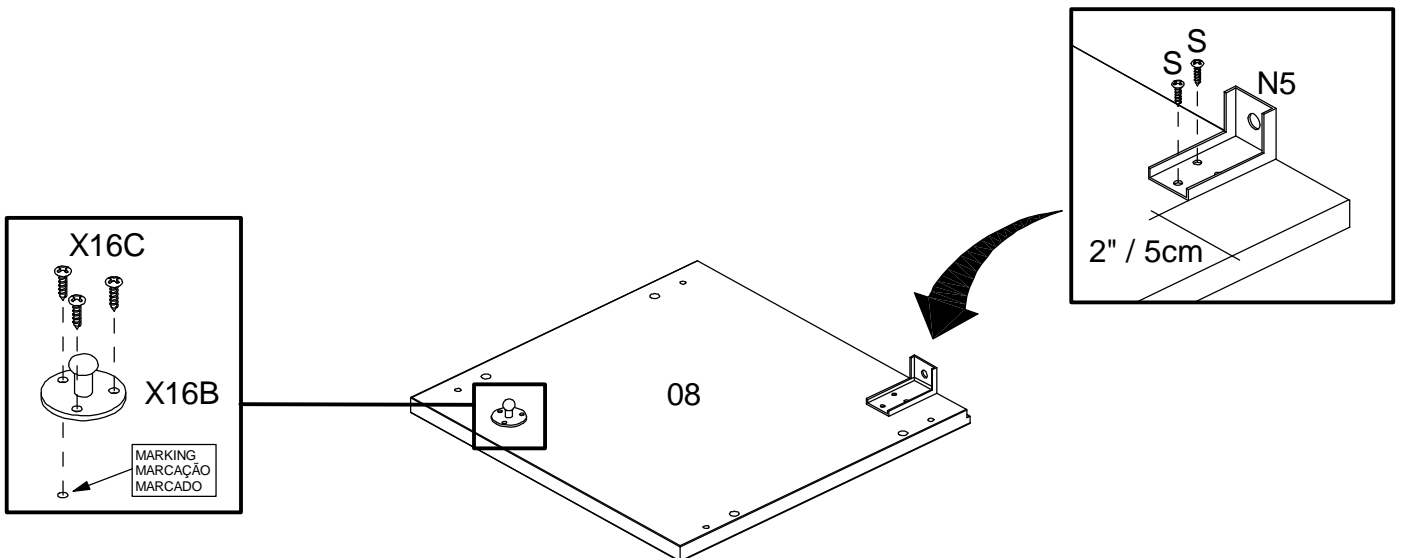

04

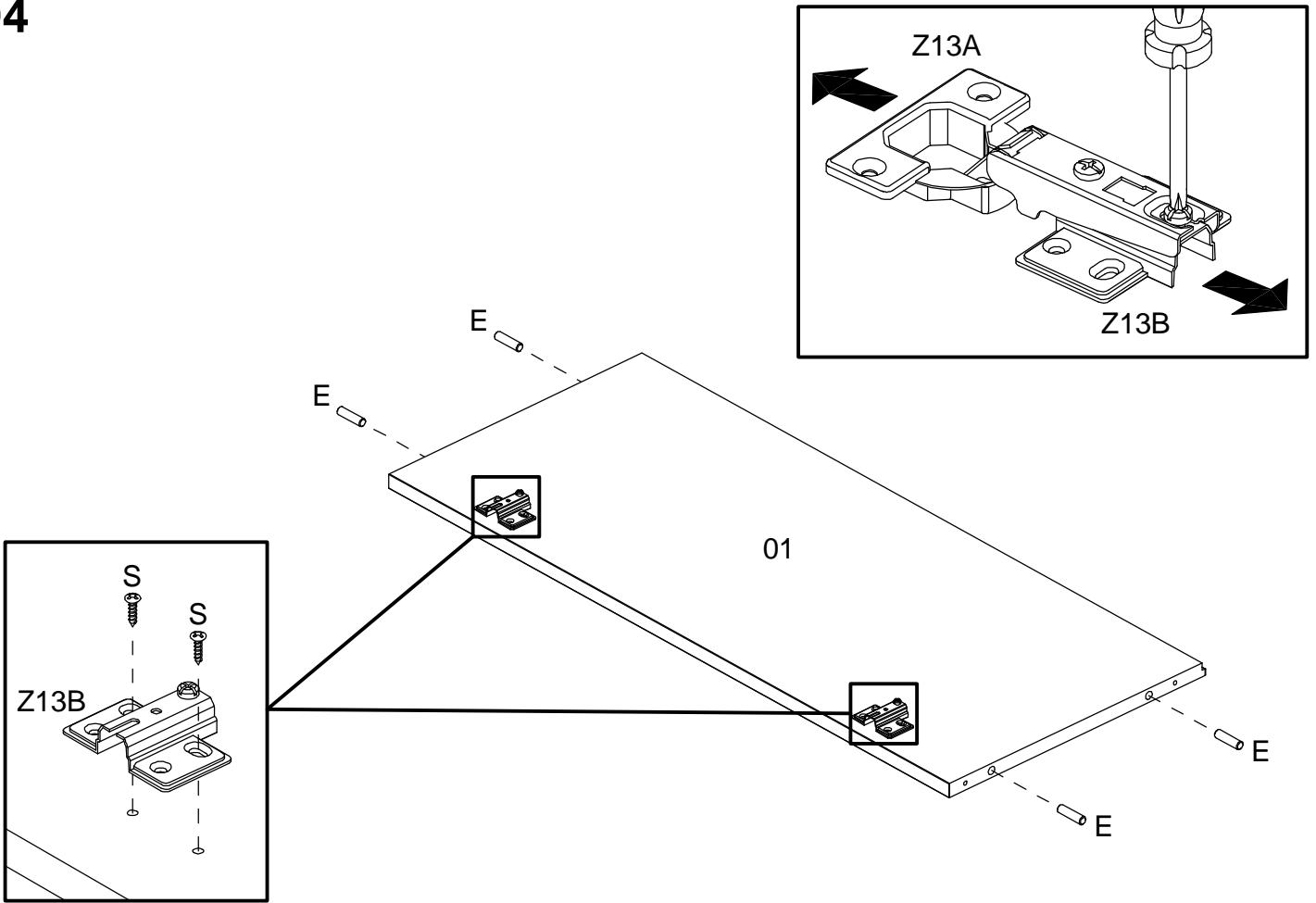

05

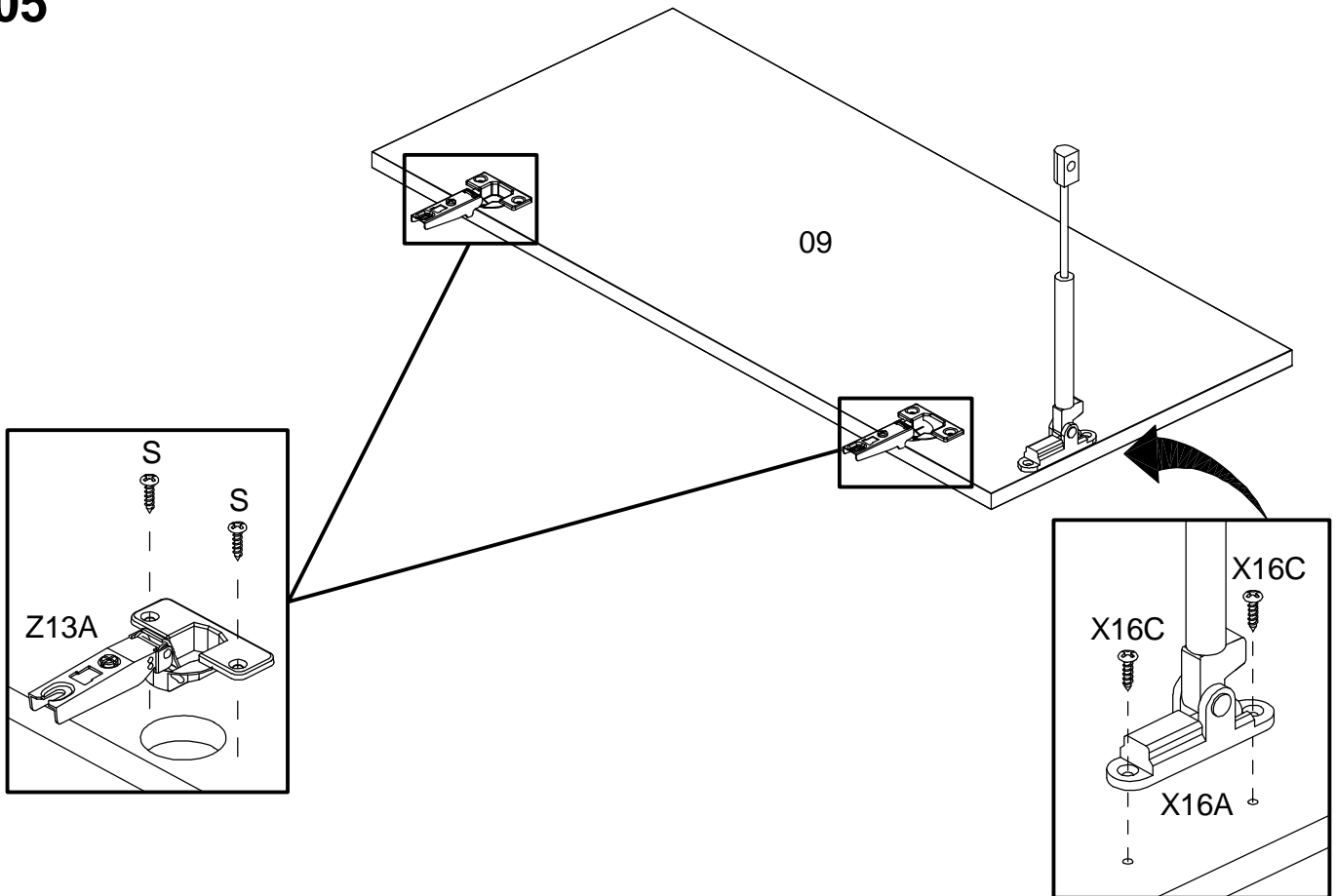

ASSEMBLY  
MONTAGEM / ARMADO

06

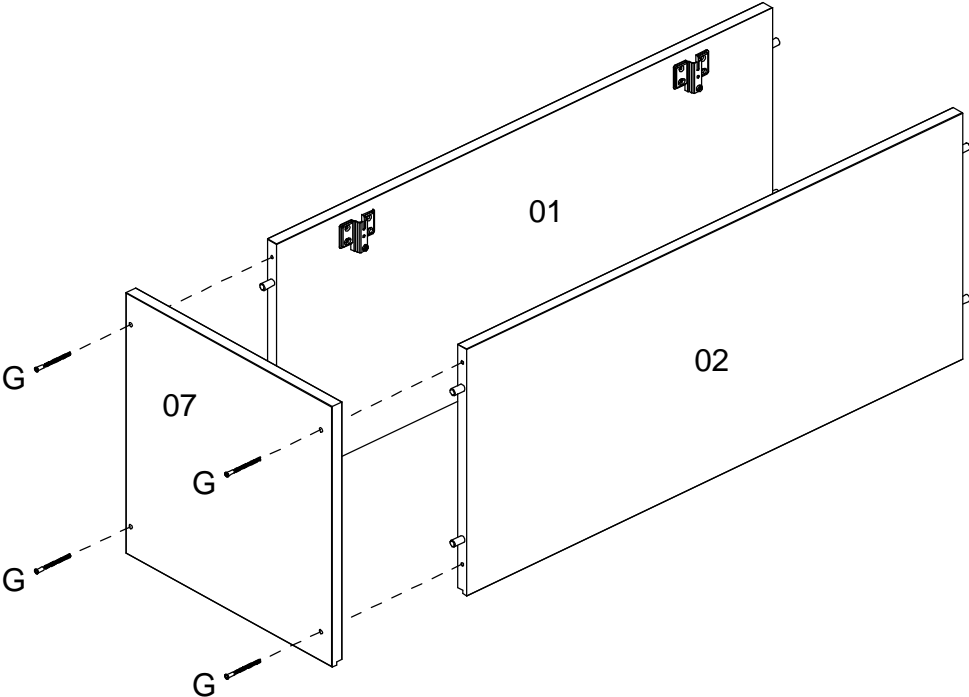
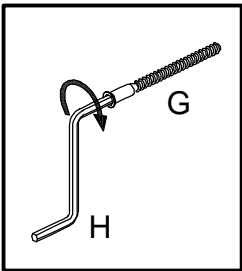

07

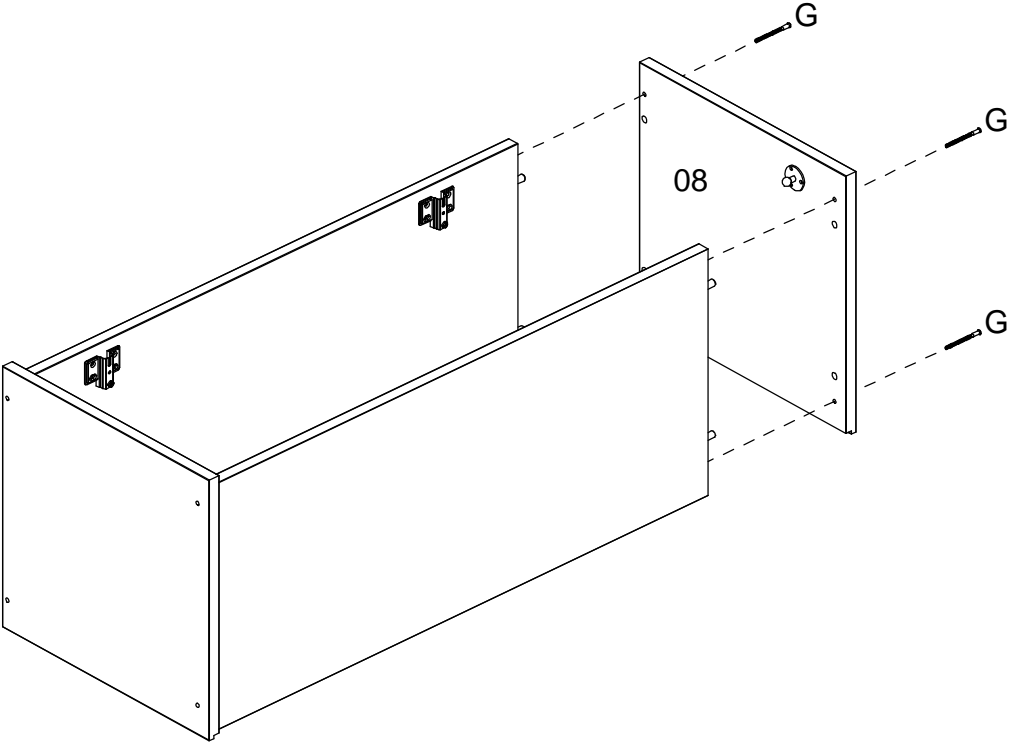

08

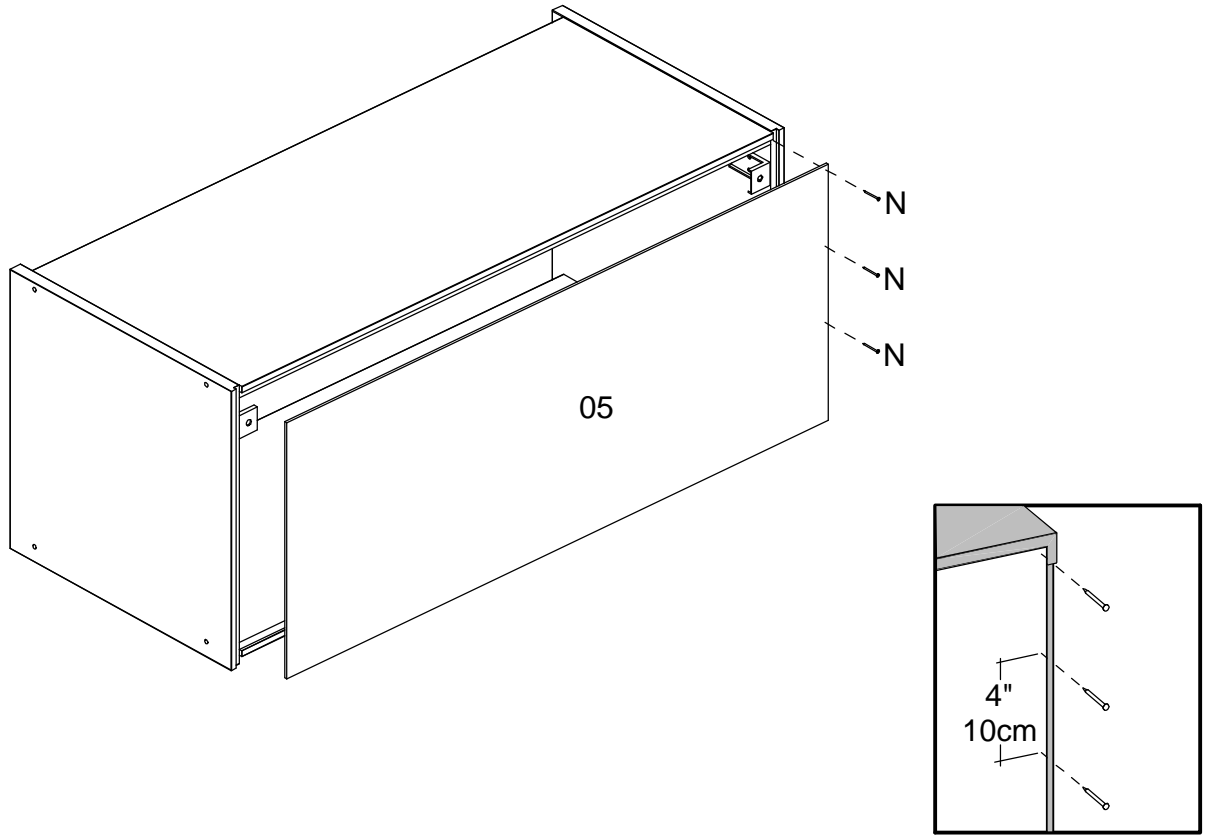

09

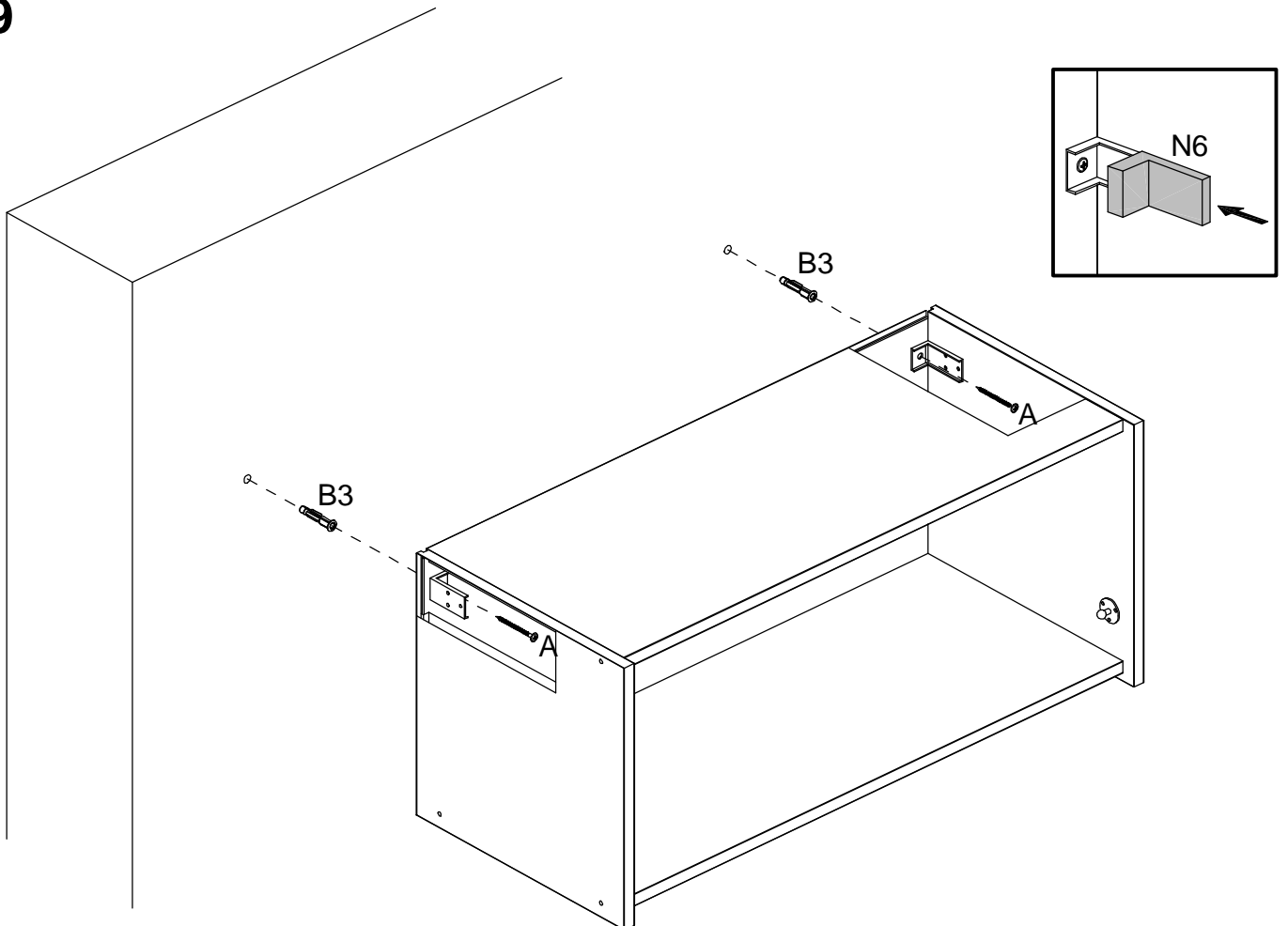

10

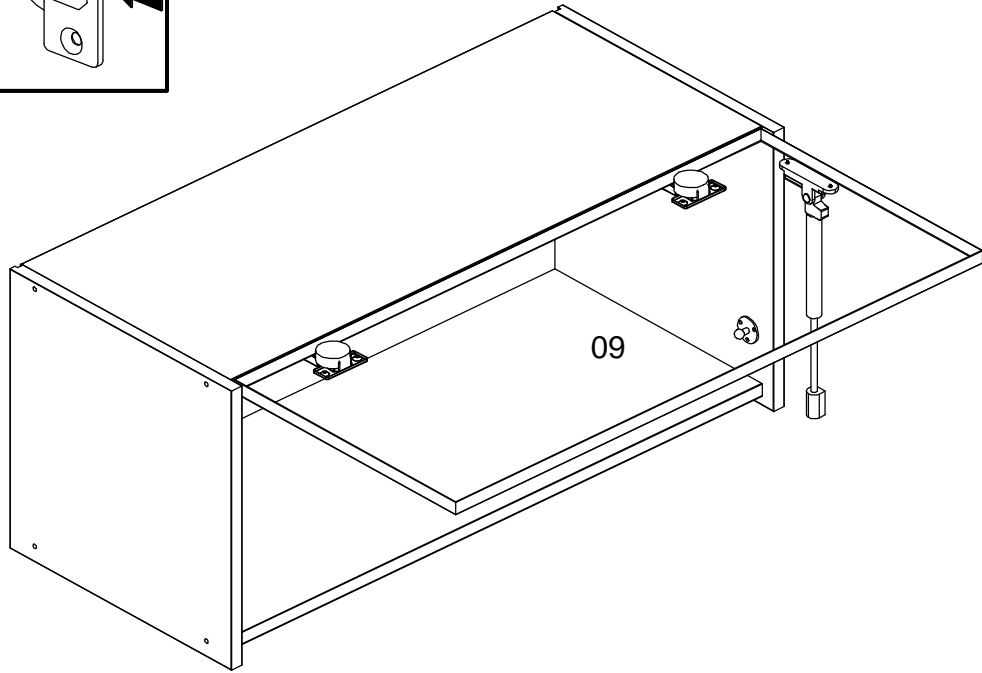
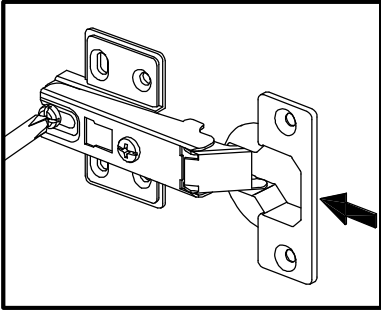

11

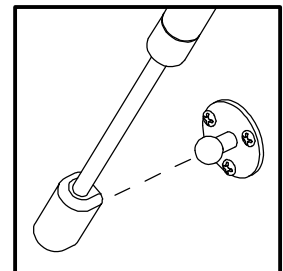
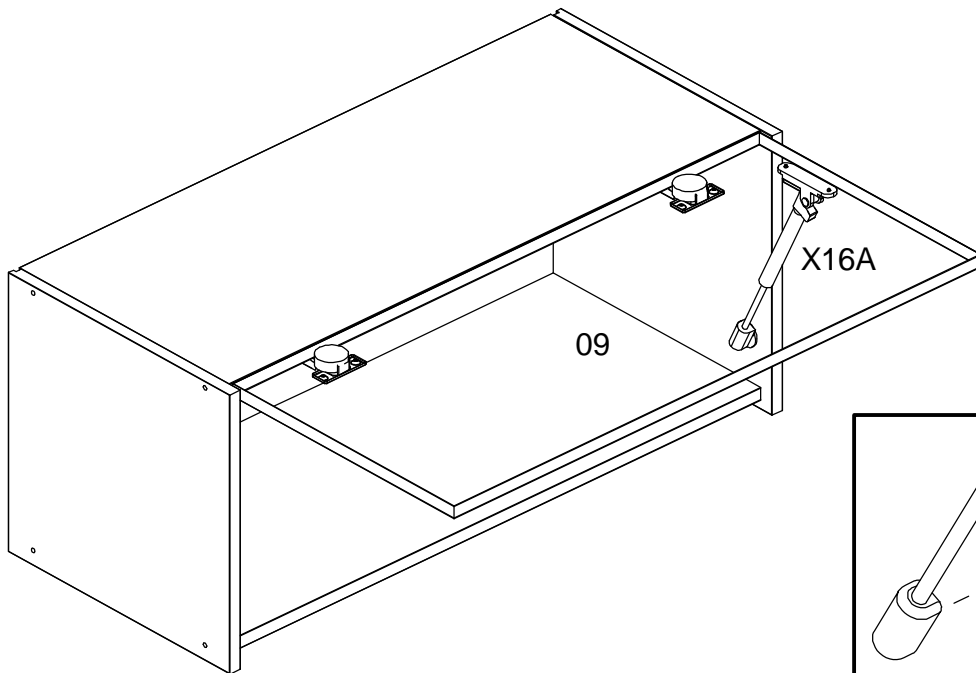



12

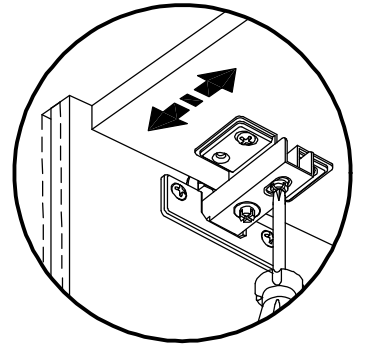
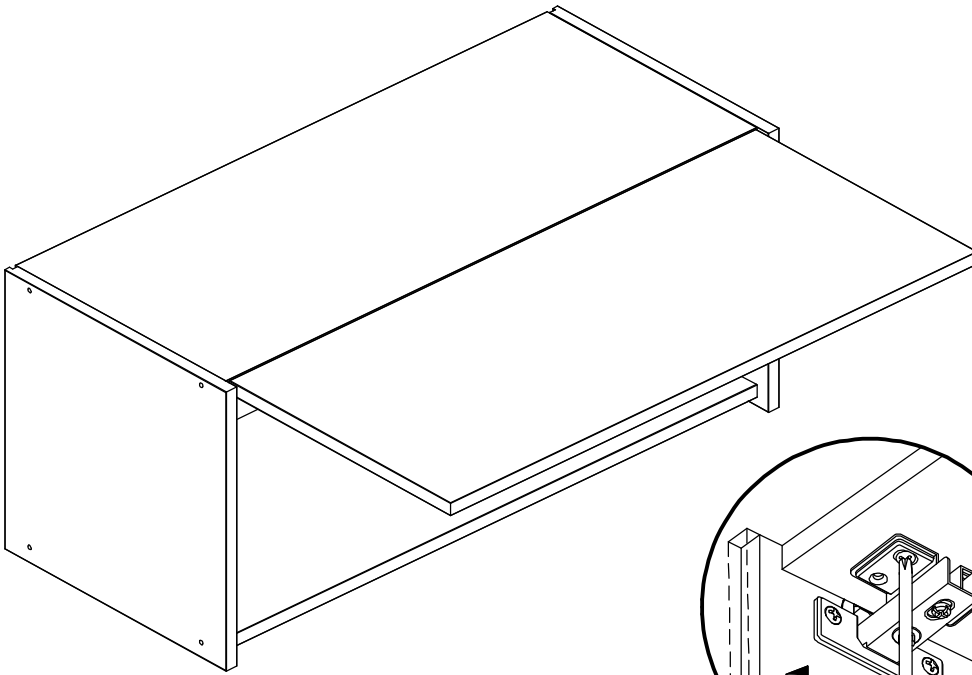

Depth Adjustment  
Regulagem Profundidade  
Ajuste Profundidad

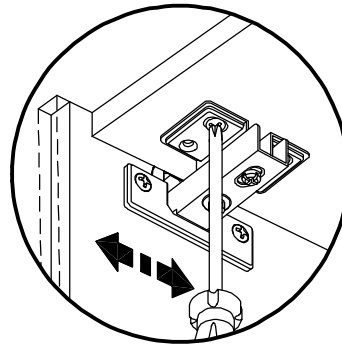

Horizontal Adjustment  
Regulagem Horizontal  
Ajuste Horizontal

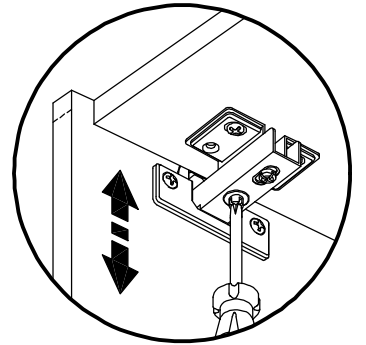

Vertical Adjustment  
Regulagem Vertical  
Ajuste Vertical

13

