

ASSEMBLY INSTRUCTIONS MANUAL DE MONTAGEM / INSTRUCCIONES DE ARMADO

CANELONE WALL CABINET 2 DOORS 31 1/2"

AEREO 2 PORTAS 800MM CANELONE

ARMARIO DE PARED 2 PUERTAS 800MM CANELONE

Reference
Referência
Referencia

220368

Revised
Revisão
Revisión

00



ENGLISH
PORTUGUÊS
ESPAÑOL

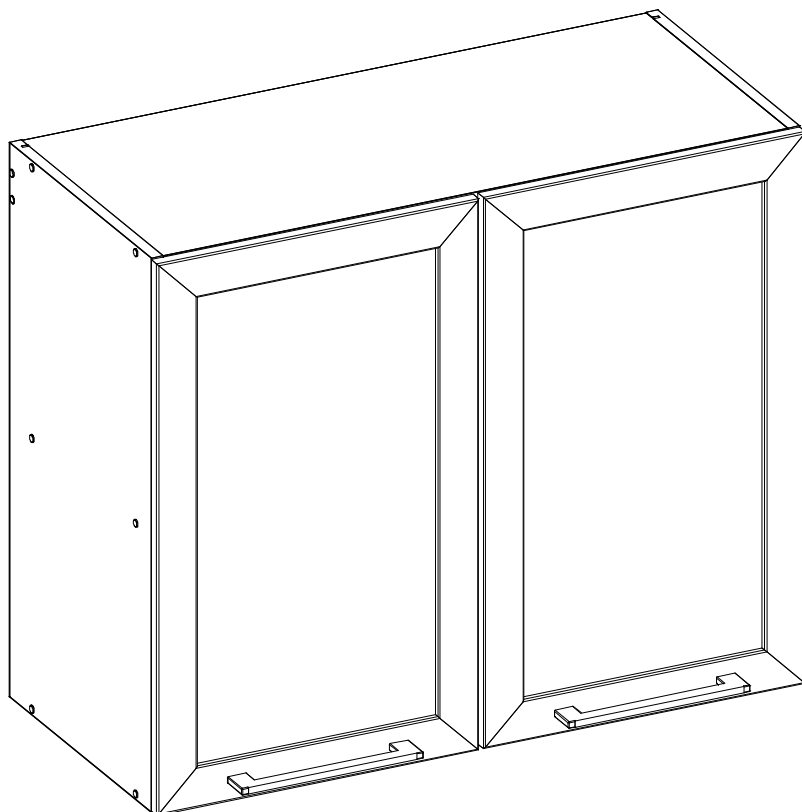

MAXIMUM RECOMMENDED WEIGHT
BEING THIS EVENLY DISTRIBUTED.

PESO MÁXIMO RECOMENDADO SENDO
ESTE DISTRIBUÍDO UNIFORMEMENTE.

PESO MÁXIMO RECOMENDADO SIENDO
ESTE UNIFORMEMENTE DISTRIBUIDO.

	LB	KG
F	22	10

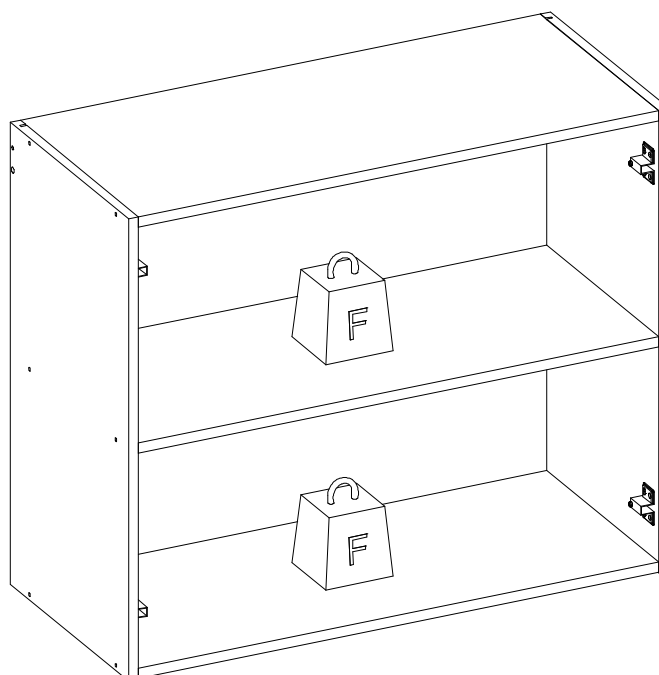

Nº	Measures_Inches	Medidas_cm	Qty./Qtd.
01	30 3/8 x 13 3/4 x 5/8	77.0 x 35.0 x 1.5	1
02	30 3/8 x 13 x 5/8	77.0 x 33.1 x 1.5	1
03	30 3/8 x 13 3/4 x 5/8	77.0 x 35.0 x 1.5	1
04	26 3/8 x 13 3/4 x 5/8	67.0 x 35.0 x 1.5	1
05	2 3/4 x 30 3/8 x 5/8	7.0 x 77.0 x 1.5	1
06	26 3/8 x 13 3/4 x 5/8	67.0 x 35.0 x 1.5	1
07	30 7/8 x 12 7/8 x 1/8	78.4 x 32.6 x 0.3	2
41	26 1/4 x 15 5/8 x 5/8	66.6 x 39.7 x 1.5	2

PARTS IDENTIFICATION IDENTIFICAÇÃO DAS PEÇAS / IDENTIFICACIÓN DE LAS PIEZAS

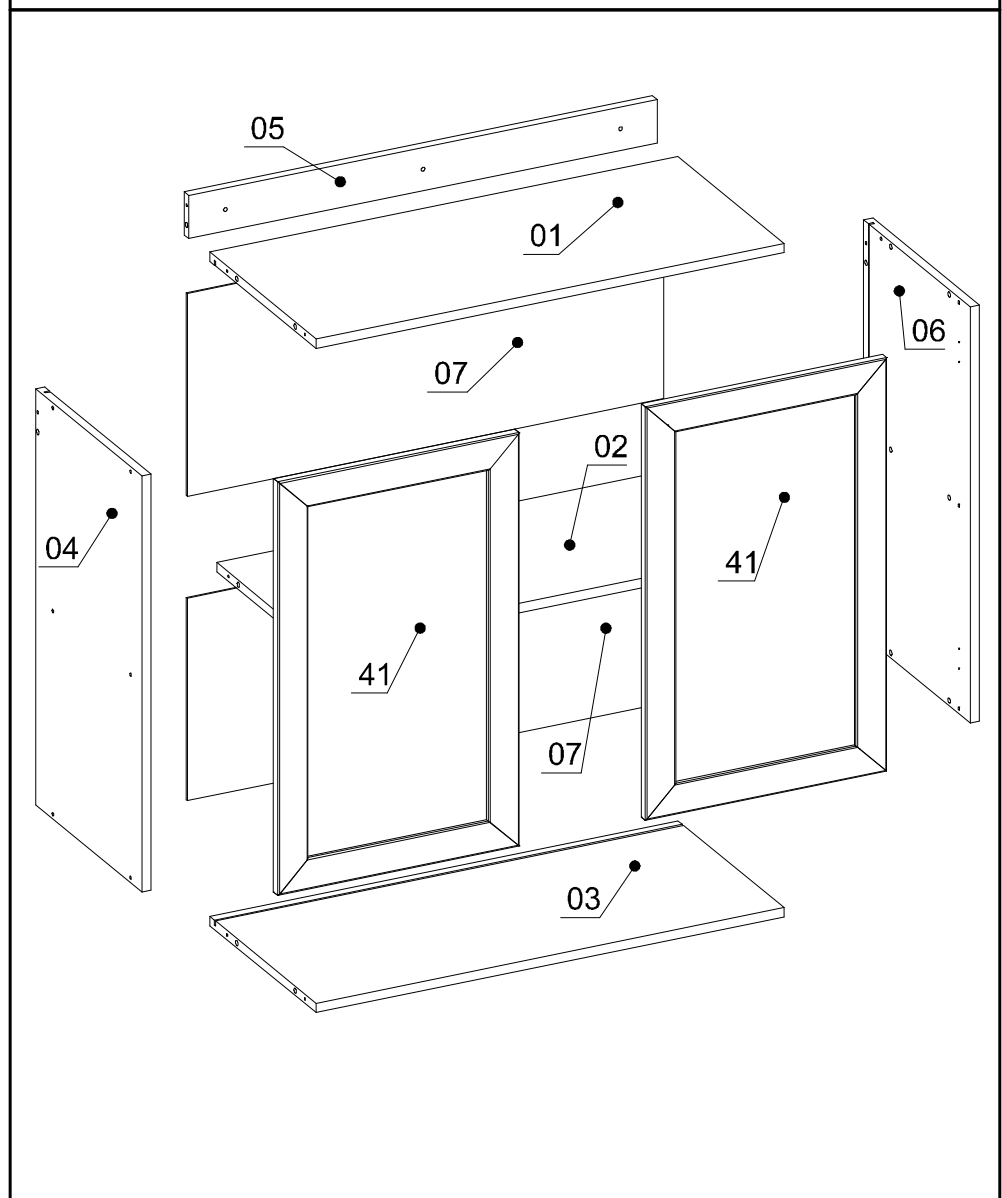

YOU WILL NEED / VOCÊ VAI PRECISAR DE / USTED NECESITARÁ

Tools not supplied / Ferramentas não fornecidas / Herramientas no incluidas

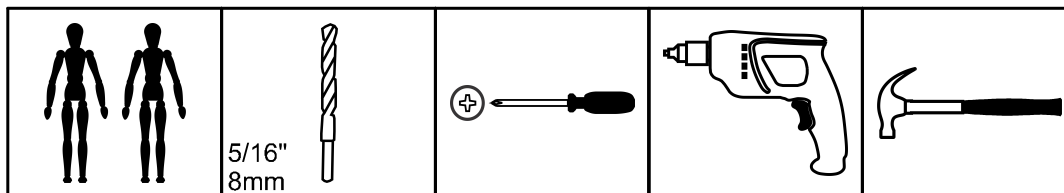

2 People
2 Pessoas
2 Personas

5/16"
8mm
Drill bit
Broca
Taladro

Screwdriver Phillips
Chave Phillips
Destornillador cruz

Drill machine
Furadeira
Taladro

Hammer
Martelo
Martillo











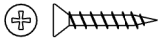
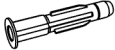

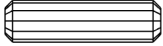
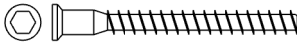

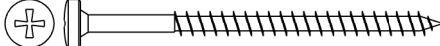
The separation of the accessories before you start the assembly will facilitate the same. In case of doubt on the size of the screws and bolts, use the ruler to bottom of page 3.

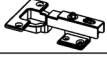
A separação dos acessórios antes de iniciar a montagem facilitará a mesma. Em caso de dúvida no tamanho dos parafusos e cavilhas, utilize a régua ao final da página 3.

La separación de los accesorios antes de comenzar el armado facilitará el mismo. En caso de duda sobre el tamaño de los tornillos y taquetes, utilice la regla al pie de página 3.

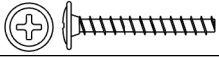
IDENTIFICATION OF ACCESSORIES IDENTIFICAÇÃO DOS ACESSÓRIOS/ IDENTIFICACIÓN DE ACCESORIOS

A8		Flat head screw / Parafuso chato / Tornillo de cabeza plana	3,5x20 mm	6
B3		Bushing / Bucha expansiva / Tapón	8x50 mm	3
C1		Metal claw / Garra de metal / Garra metal	-	4
E		Wooden dowel / Cavilha / Taquete	8x30 mm	14
G		Structural screw / Parafuso estrutural / Tornillo estructural	5,0x50 mm	14
H		Allen key / Chave allen / Liave allen	3 mm	1
I		Structural screw cover/Tampa parafuso estrutural/Tapa tornillo estructural	-	14
i4		Pan head screw / Parafuso panela / Tornillo de pan	5,0x70 mm	3
K11		Silicone stop / Batente de silicone / Tope de silicona	8 mm	2
M17		Metal hinge straight / Dobradiça reta / Bisagra recta	35 mm	4
N		Nail / Prego / Clavo	10x10	4
o1		Triangular support / Suporte triangular / Soporte triangular	-	6
S		Pan head screw / Parafuso panela / Tornillo de pan	3,5x14 mm	24
T		Flanged head screw / Parafuso flangeado / Tornillo de cabeza flangeada	3,5x25 mm	4
X19		Handle / Puxador Citrino / Tirador	192 mm	2
Z		Plastic hole plugs / Tapa furo plástico / Tapones plásticos	8 mm	2

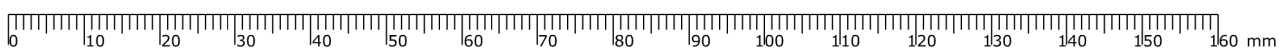

PRE-ASSEMBLE
PRÉ-MONTAGEM / PRE ARMADO

01

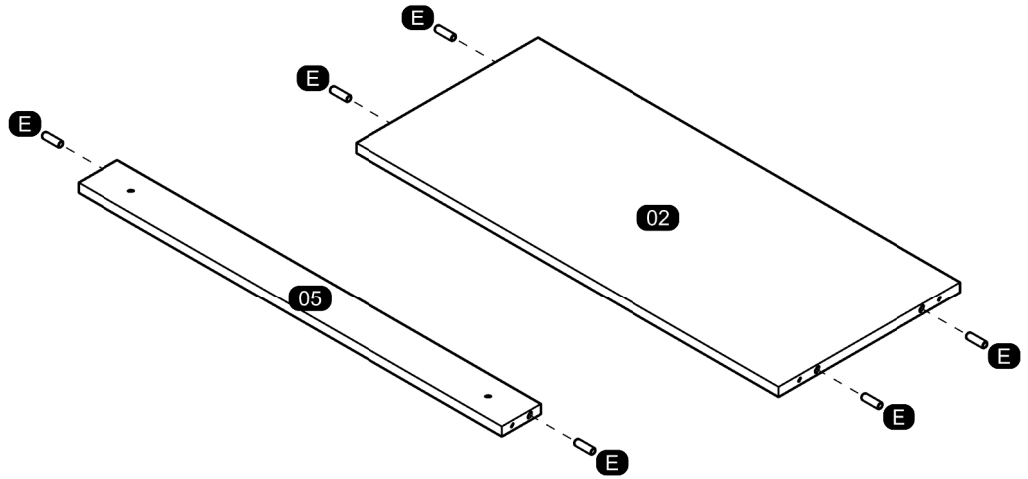
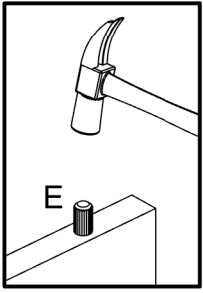

02

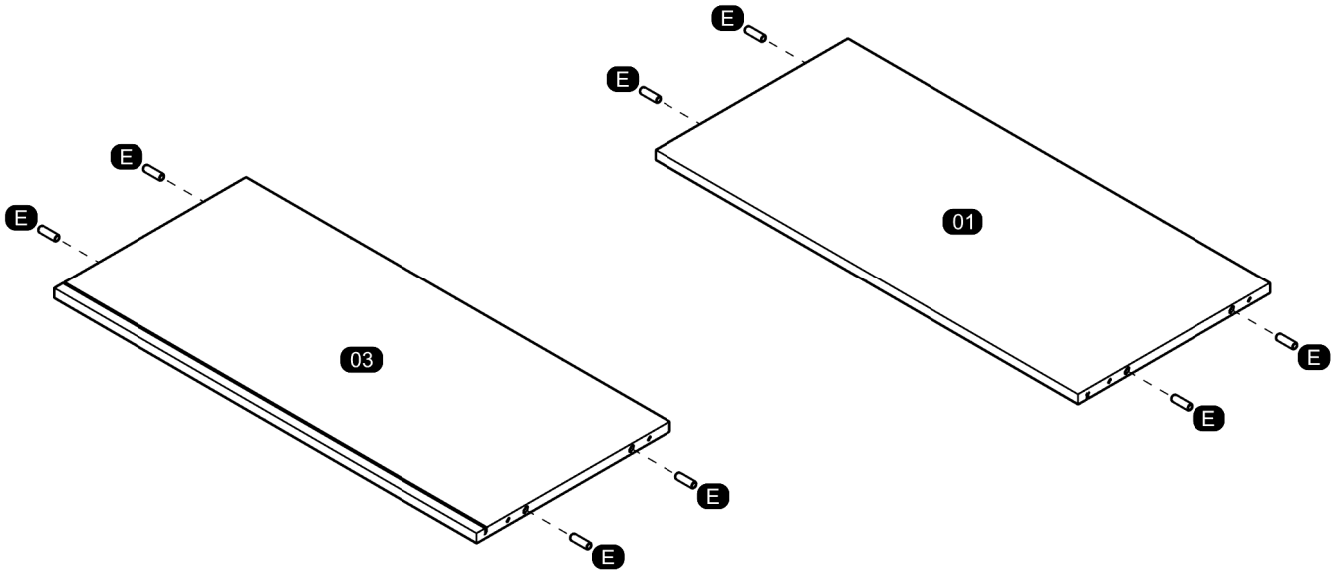

03

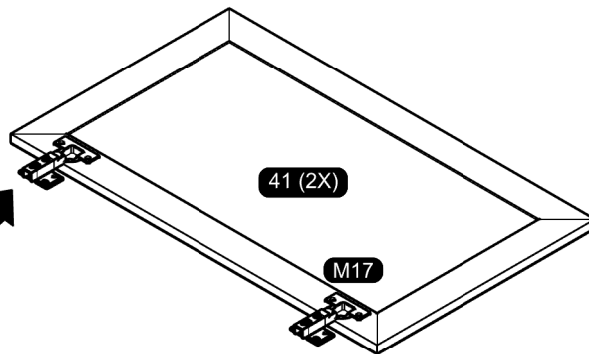
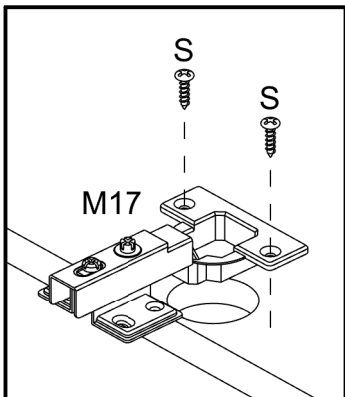

ASSEMBLY
MONTAGEM / ARMADO

04

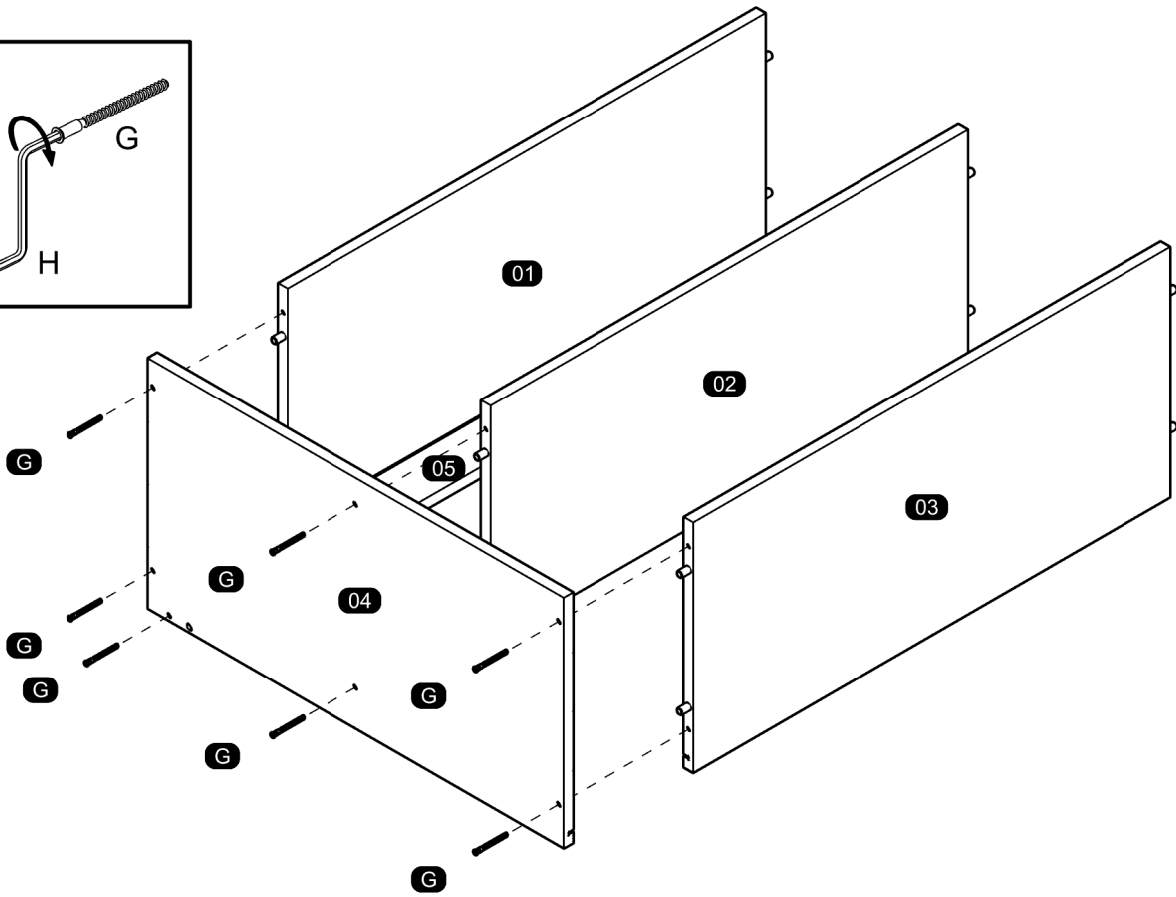
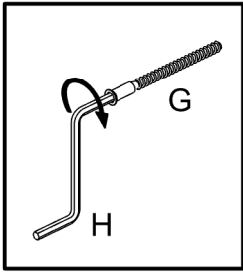

05

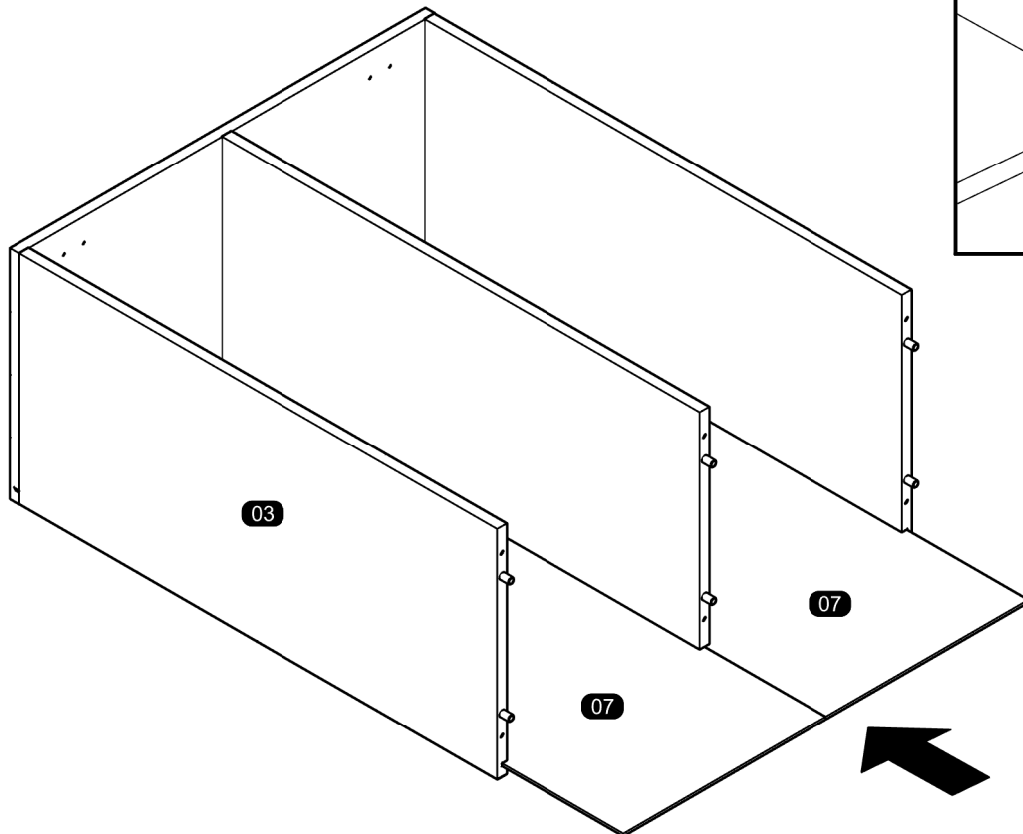
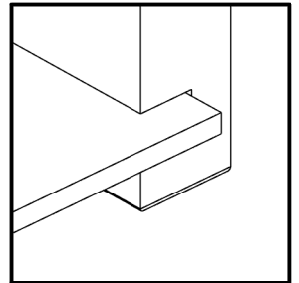

06

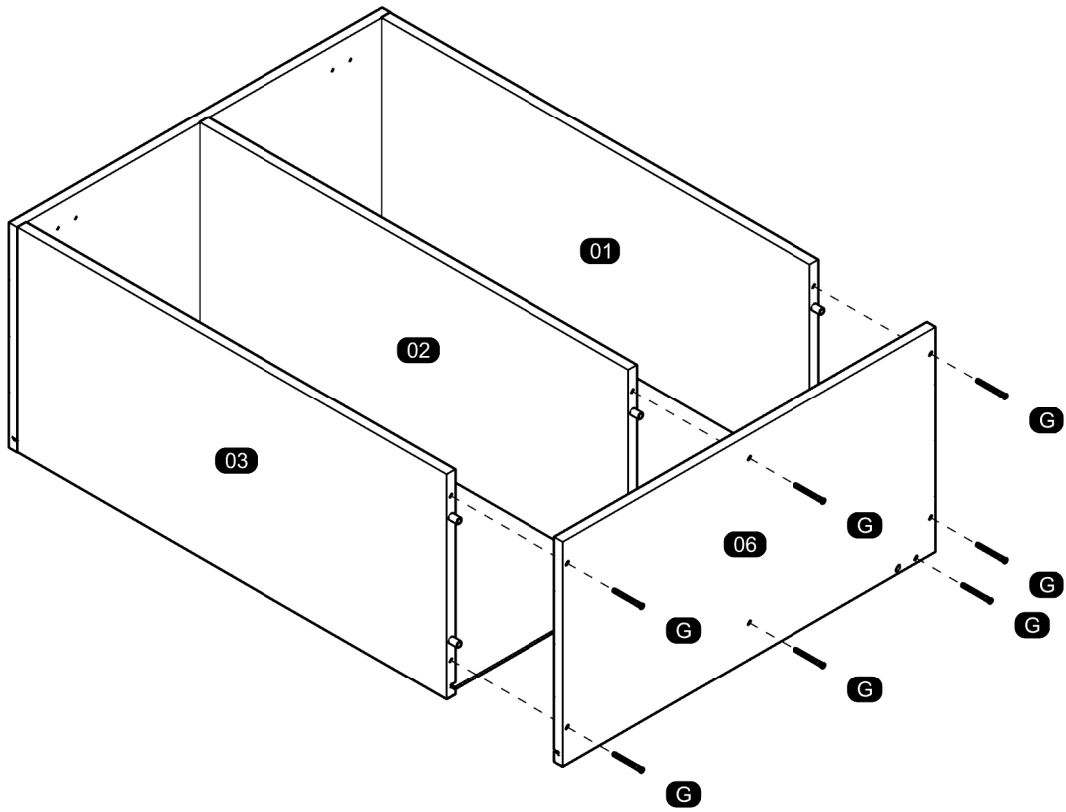

07

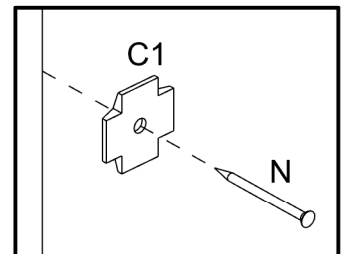
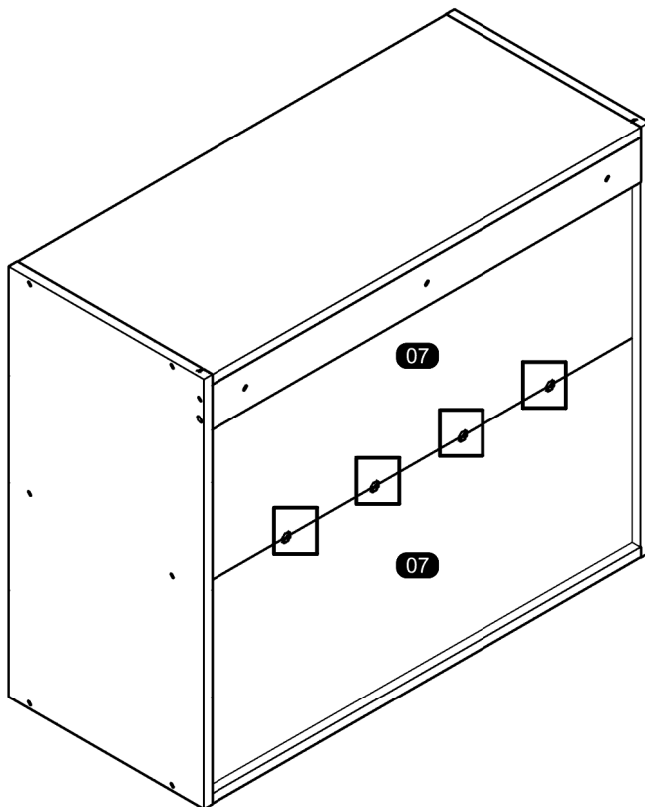

08

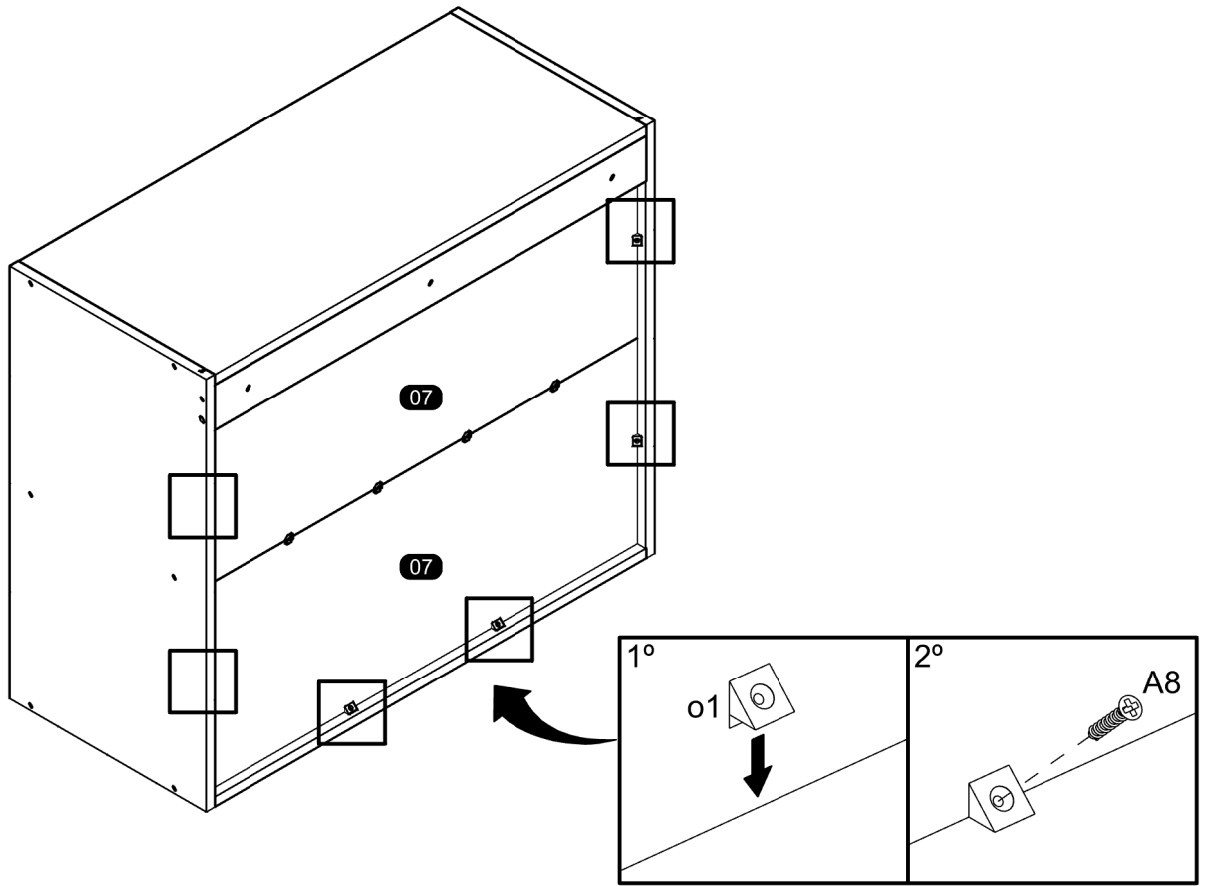

09

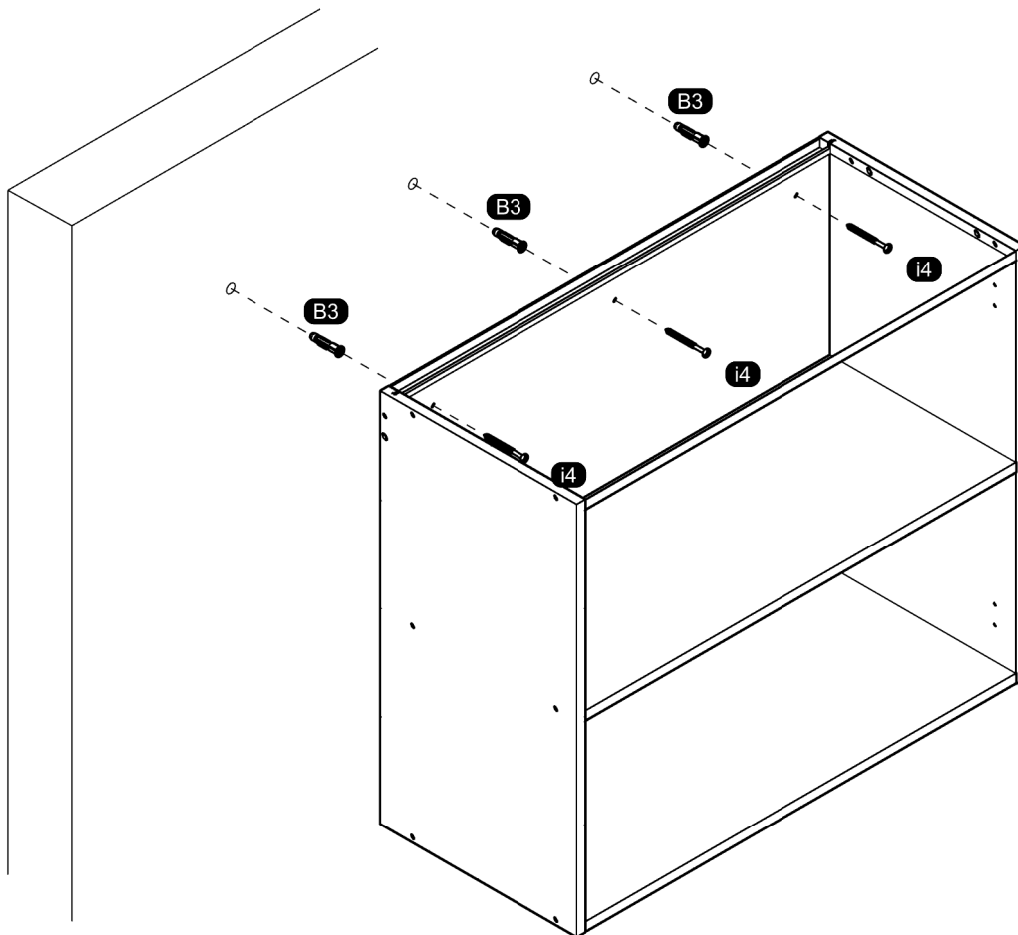

10

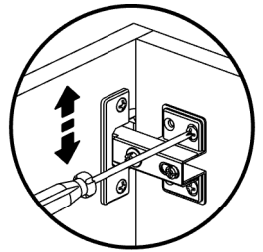
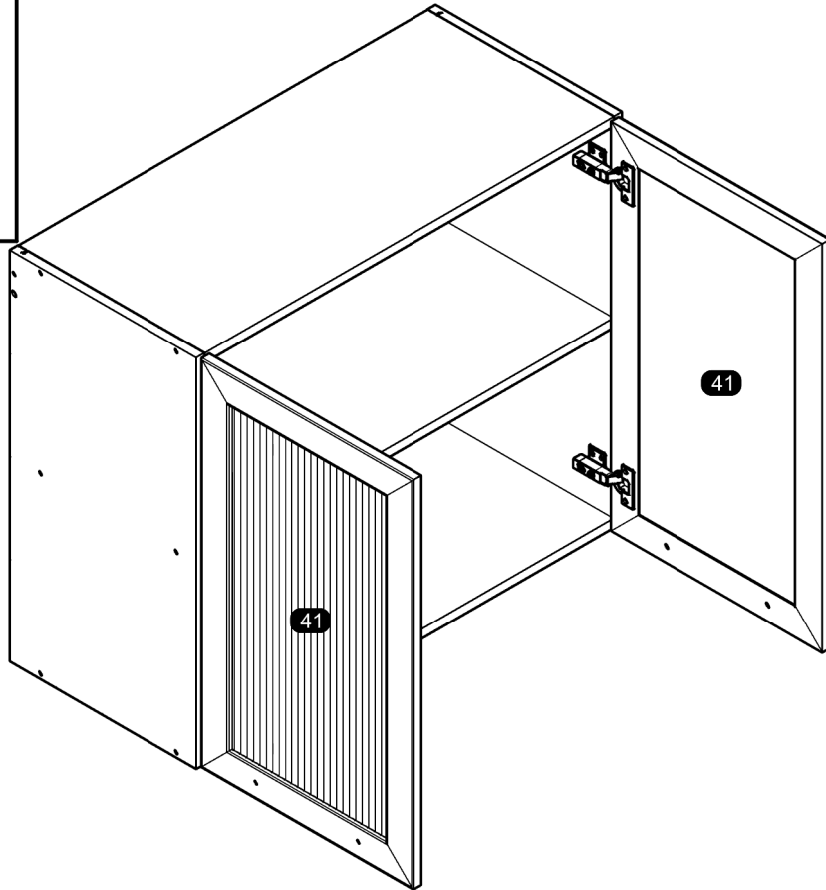
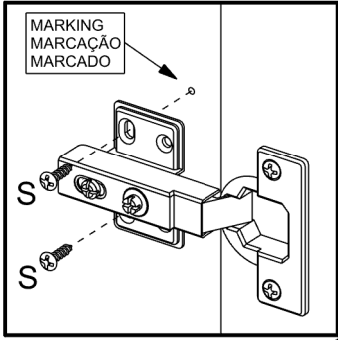

Vertical Adjustment
Regulagem Vertical
Ajuste Vertical

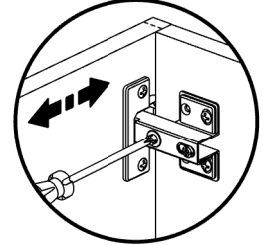

Horizontal Adjustment
Regulagem Horizontal
Ajuste Horizontal

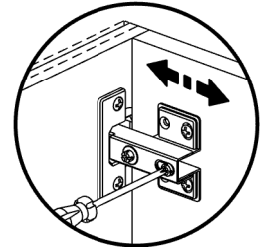

Depth Adjustment
Regulagem Profundidade
Ajuste Profundidad

11

