

ASSEMBLY INSTRUCTIONS MANUAL DE MONTAGEM / INSTRUCCIONES DE ARMADO

CAMPANELE BASE CABINET 2 DOORS 3 DRAWERS 47 1/4"

BALCÃO 2 PORTAS 3 GAVETAS 1200MM CAMPANELE

GABINETE 2 PUERTAS 3 CAJONES 1200MM CAMPANELE

Reference
Referência
Referencia

200039

Revised
Revisão
Revisión

03



ENGLISH
PORTUGUÊS
ESPAÑOL

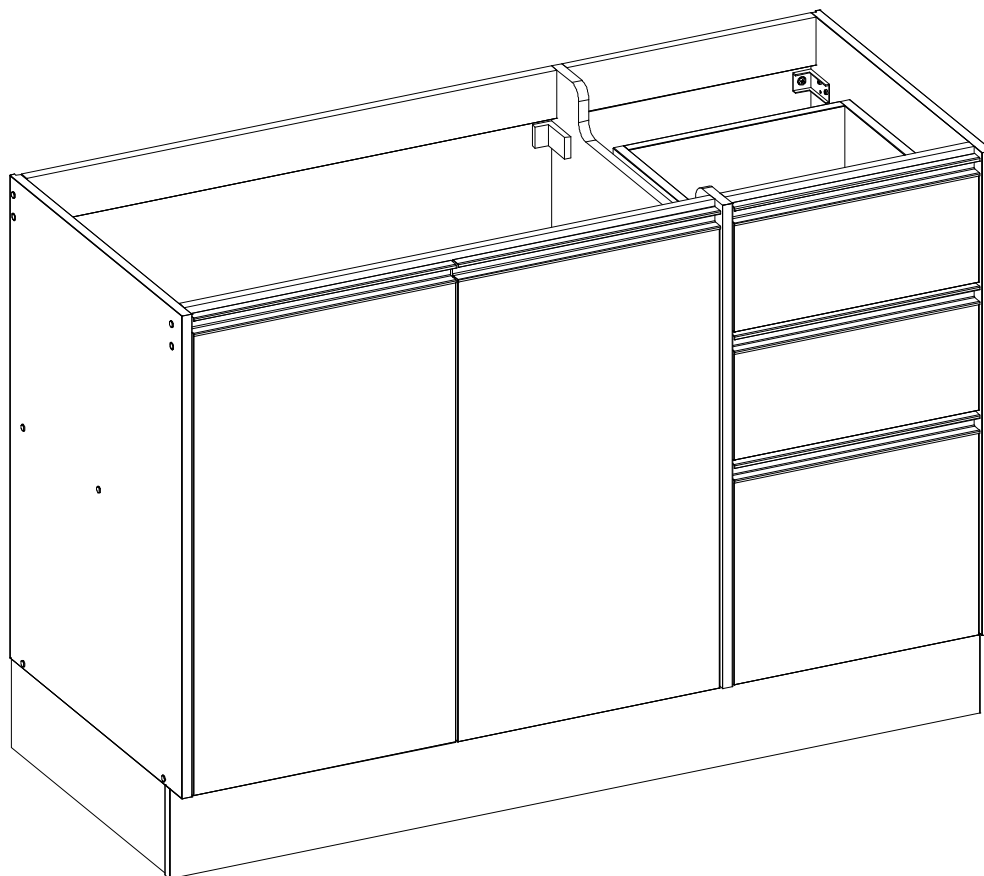

MAXIMUM RECOMMENDED WEIGHT
BEING THIS EVENLY DISTRIBUTED.

PESO MÁXIMO RECOMENDADO SENDO
ESTE DISTRIBUÍDO UNIFORMEMENTE.

PESO MÁXIMO RECOMENDADO SIENDO
ESTE UNIFORMEMENTE DISTRIBUIDO.

| | LB | KG |
|---|----|----|
| – | | |
| D | 11 | 5 |
| F | 22 | 10 |

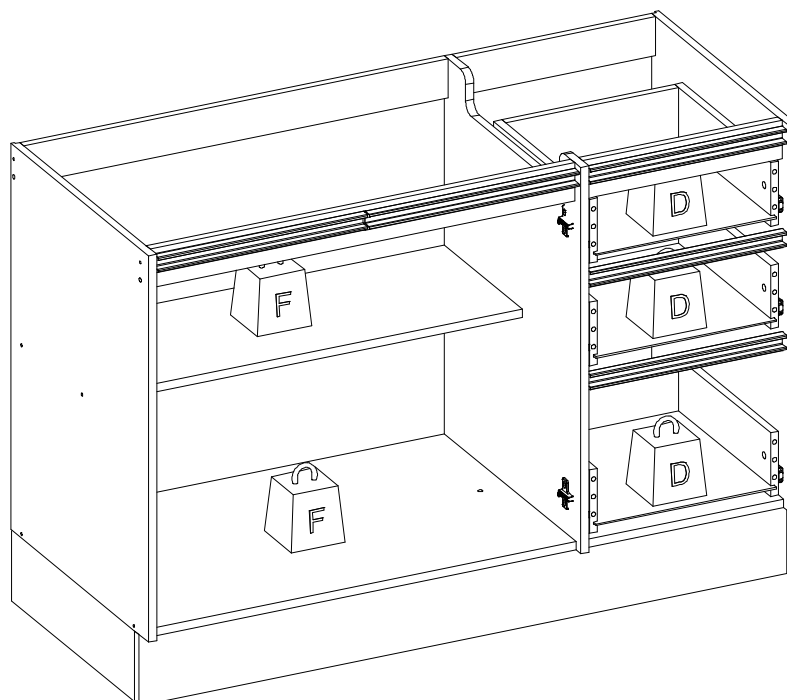

| Nº | Measures_Inches | Medidas_cm | Qty./Qtd. |
|----|-----------------------|--------------------|-----------|
| 01 | 30 7/8 x 2 3/4 x 5/8 | 78.5 x 7.0 x 1.5 | 2 |
| 03 | 14 1/2 x 2 3/4 x 5/8 | 36.9 x 7.0 x 1.5 | 2 |
| 19 | 31 1/2 x 13 1/2 x 1/8 | 80.0 x 34.2 x 0.3 | 2 |
| 20 | 26 7/8 x 15 1/8 x 1/8 | 68.4 x 38.3 x 0.3 | 1 |
| 24 | 47 1/4 x 5 1/8 x 5/8 | 119.9 x 13.0 x 1.5 | 1 |
| 25 | 18 1/8 x 5 1/8 x 5/8 | 45.9 x 13.0 x 1.5 | 2 |
| 27 | 11 3/8 x 30 7/8 x 5/8 | 29.0 x 78.5 x 1.5 | 1 |
| 28 | 19 3/8 x 30 7/8 x 5/8 | 49.3 x 78.5 x 1.5 | 1 |
| 29 | 19 3/8 x 14 1/2 x 5/8 | 49.3 x 36.9 x 1.5 | 1 |
| 30 | 20 1/8 x 27 1/2 x 5/8 | 51.0 x 70.0 x 1.5 | 1 |
| 31 | 19 7/8 x 27 1/2 x 5/8 | 50.6 x 70.0 x 1.5 | 1 |
| 32 | 20 1/8 x 27 1/2 x 5/8 | 51.0 x 70.0 x 1.5 | 1 |
| 33 | 26 3/8 x 15 1/4 x 5/8 | 67.0 x 38.8 x 1.5 | 2 |
| 34 | 14 1/4 x 6 1/4 x 5/8 | 36.3 x 15.8 x 1.5 | 2 |
| 35 | 14 1/4 x 11 3/4 x 5/8 | 36.3 x 29.7 x 1.5 | 1 |
| 36 | 12 5/8 x 4 1/2 x 5/8 | 32.0 x 11.5 x 1.5 | 3 |
| 37 | 13 7/8 x 13 1/8 x 1/8 | 35.4 x 33.4 x 0.3 | 3 |
| 96 | 14 x 4 1/2 x 5/8 | 35.5 x 11.5 x 1.5 | 3 |
| 97 | 14 x 4 1/2 x 5/8 | 35.5 x 11.5 x 1.5 | 3 |

PARTS IDENTIFICATION IDENTIFICAÇÃO DAS PEÇAS / IDENTIFICACIÓN DE LAS PIEZAS

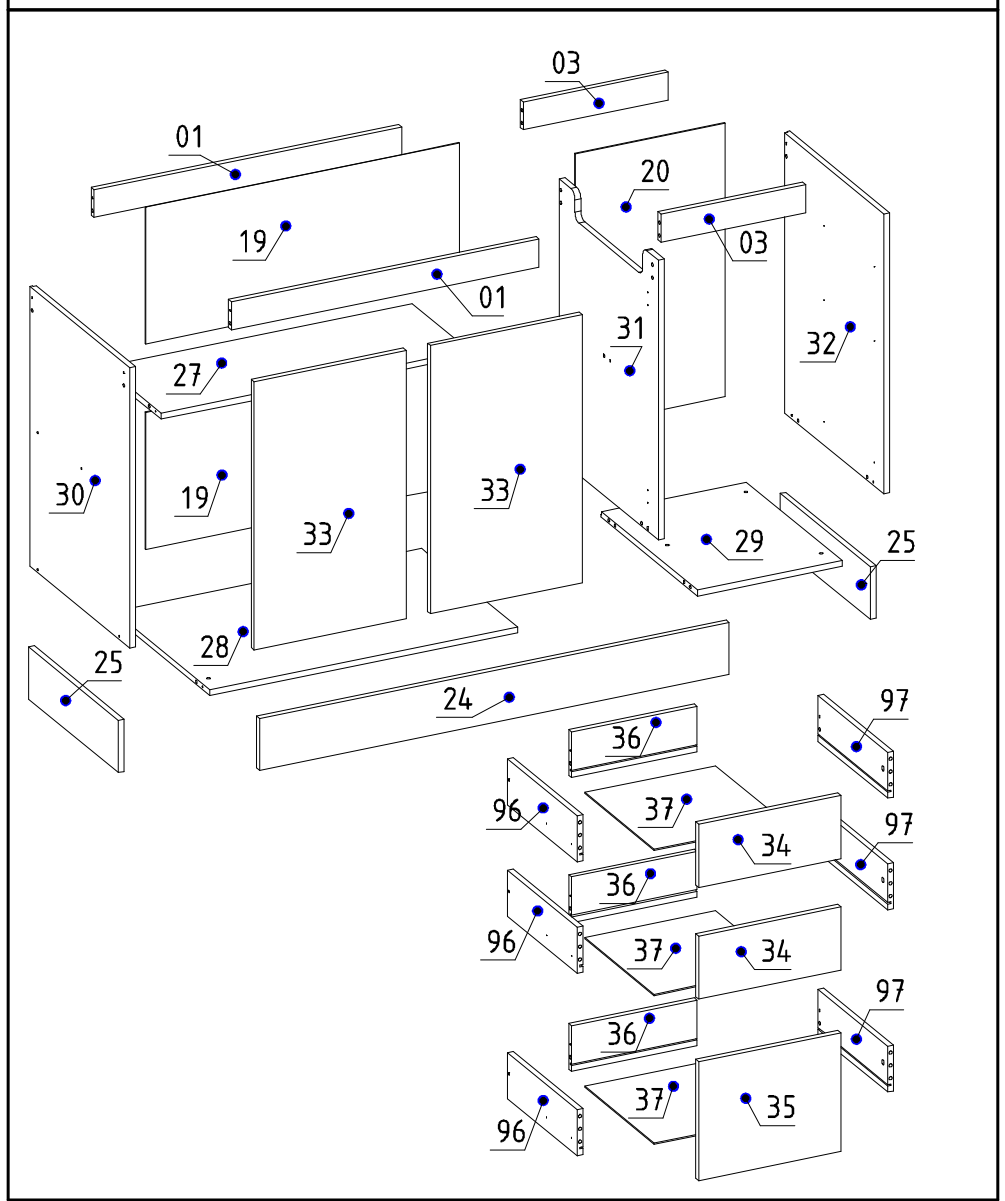

YOU WILL NEED / VOCÊ VAI PRECISAR DE / USTED NECESITARÁ

Tools not supplied / Ferramentas não fornecidas / Herramientas no incluidas

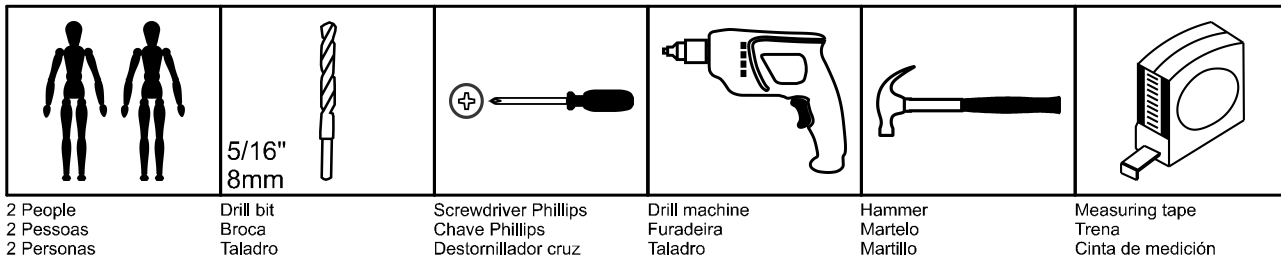









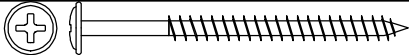

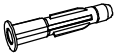



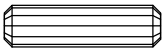
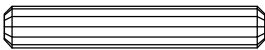
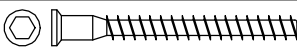

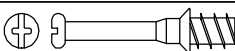

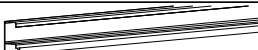
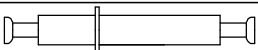

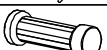

The separation of the accessories before you start the assembly will facilitate the same. In case of doubt on the size of the screws and bolts, use the ruler to bottom of page 3.

A separação dos acessórios antes de iniciar a montagem facilitará a mesma. Em caso de dúvida no tamanho dos parafusos e cavilhas, utilize a régua ao final da página 3.

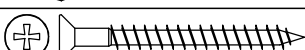
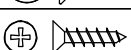
La separación de los accesorios antes de comenzar el armado facilitará el mismo. En caso de duda sobre el tamaño de los tornillos y taquetes, utilice la regla al pie de página 3.

IDENTIFICATION OF ACCESSORIES IDENTIFICAÇÃO DOS ACESSÓRIOS/ IDENTIFICACIÓN DE ACCESORIOS

| | | | | |
|-----|---|--|-----------|----|
| A |  | Flanged head screw / Parafuso flangeado / Tornillo de cabeza flangeada | 5,0x60 mm | 3 |
| A1 |  | Glue / Cola / Pegamento | 13 g | 1 |
| B3 |  | Bushing / Bucha expansiva / Tapón | 8x50 mm | 3 |
| C1 |  | Metal claw / Garra de metal / Garra metal | - | 8 |
| D5 |  | Hinge shim / Calço dobradiça / Bisagra de calce | - | 4 |
| D6 |  | Metal hinge super high / Dobradiça super alta / Bisagra alta | 26 mm | 4 |
| E |  | Wooden dowel / Cavilha / Taquete | 8x30 mm | 30 |
| F |  | Wooden dowel / Cavilha / Taquete | 8x50 mm | 4 |
| G |  | Structural screw / Parafuso estrutural / Tornillo estructural | 5,0x50 mm | 12 |
| H |  | Allen key / Chave allen / Liave allen | 3 mm | 1 |
| I |  | Structural screw cover/Tampa parafuso estrutural/Tapa tornillo estructural | - | 10 |
| J |  | Simple minifix screw / Haste minifix simples / Tornillo minifix simple | - | 6 |
| J26 |  | Handle / Puxador Perfil / Tirador | 363 mm | 3 |
| J27 |  | Handle / Puxador Perfil / Tirador | 388 mm | 2 |
| K |  | Double minifix screw / Haste minifix dupla / Tornillo minifix doble | 60mm | 4 |
| L |  | Drum lock / Tambor minifix / Tambor minifix | 12 mm | 14 |
| L1 |  | Flat head screw / Parafuso chato / Tornillo de cabeza plana | 7,0x40 mm | 6 |
| L3 |  | Plastic Foot / Sapata / Pie Plástico | - | 6 |
| L17 |  | Telescopic slide / Corrediça telescópica / Corredera telescópica | 350 mm | 6 |
| M |  | Bore patch adhesive / Tapa furo adesivo / Tapones adhesivo | - | 9 |
| N4 |  | Loop / Presilha / Presilla | - | 6 |
| N5 |  | Support "L" / Suporte "L" / Soporte "L" | - | 3 |
| N6 |  | Cover / Capa / Cubierta | - | 2 |
| O |  | Flat head screw / Parafuso chato / Tornillo de cabeza plana | 4,5x45 mm | 6 |
| P5 |  | Flat head screw / Parafuso chato especial / Tornillo de cabeza plana | 3,5x14 mm | 24 |
| S |  | Pan head screw / Parafuso panela / Tornillo de pan | 3,5x14 mm | 43 |
| X6 |  | Nail / Pregó / Clavo | 10 x 7 | 48 |
| Z |  | Plastic hole plugs / Tapa furo plástico / Tapones plásticos | 8 mm | 4 |

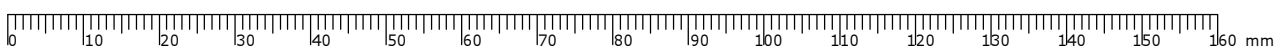

PRE-ASSEMBLE
PRÉ-MONTAGE / PRE ARMADO

01

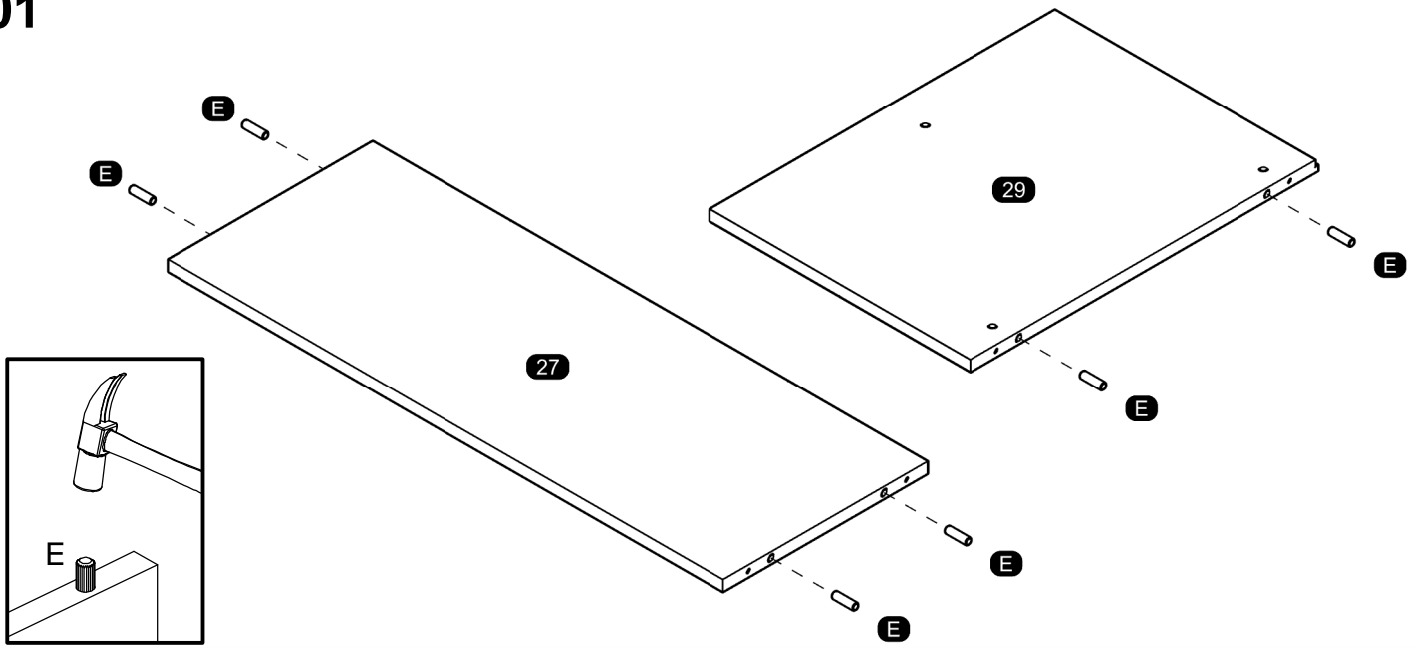

02

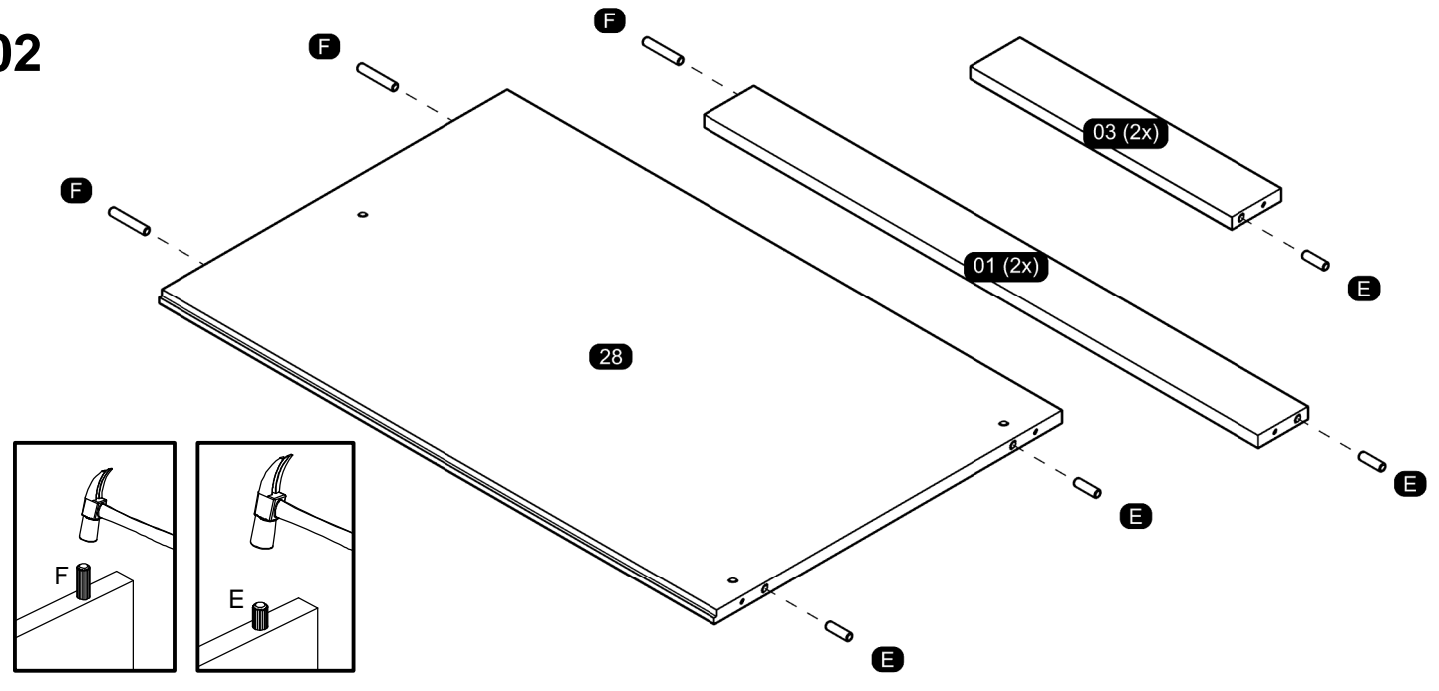

03

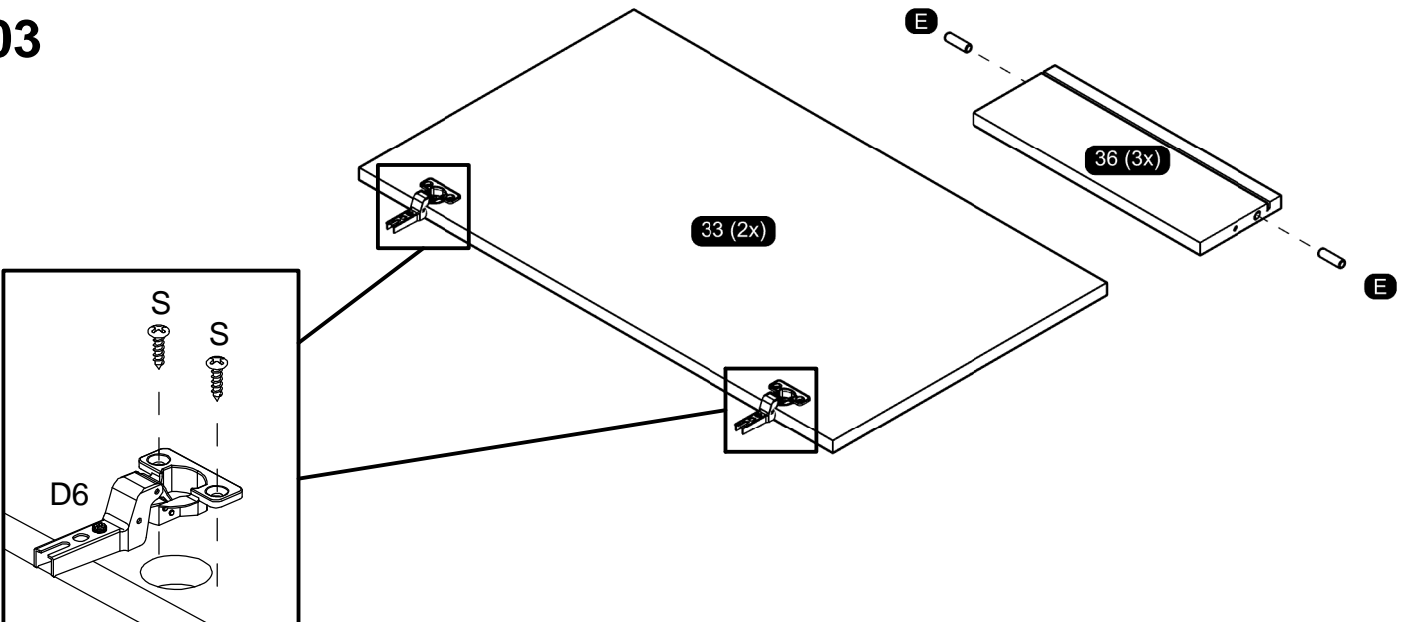

04

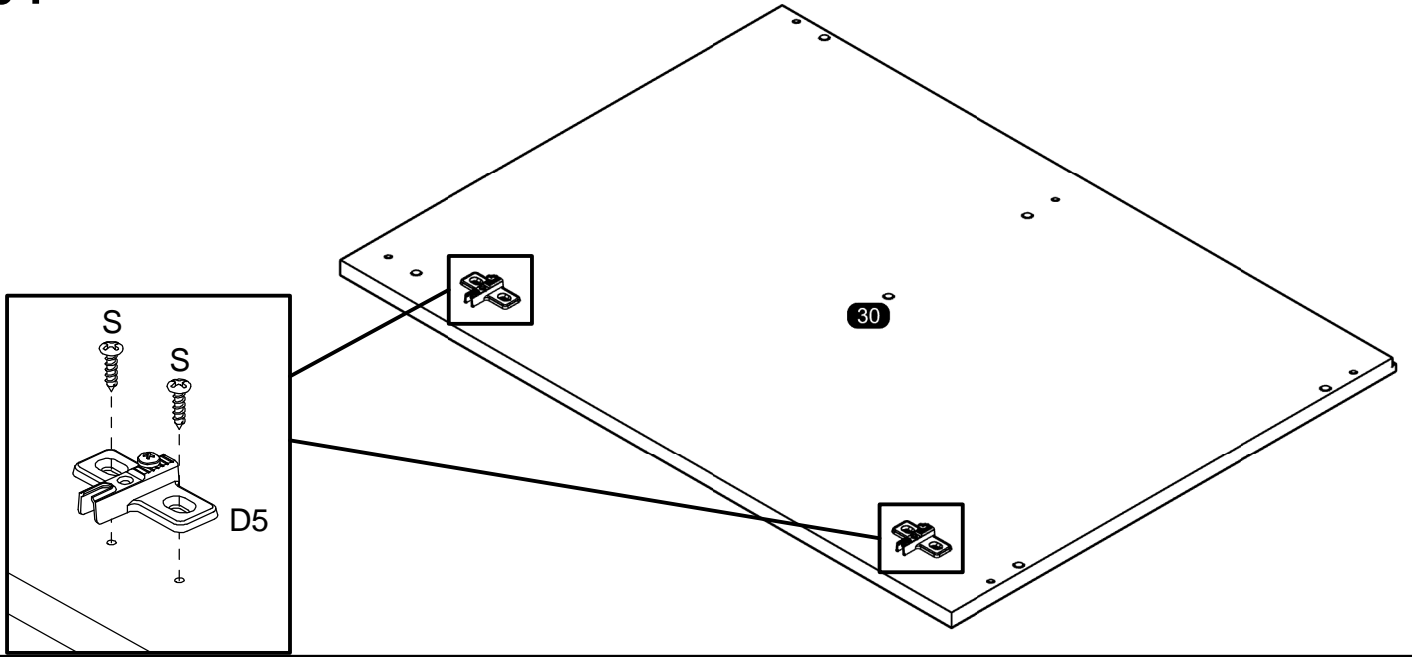

05

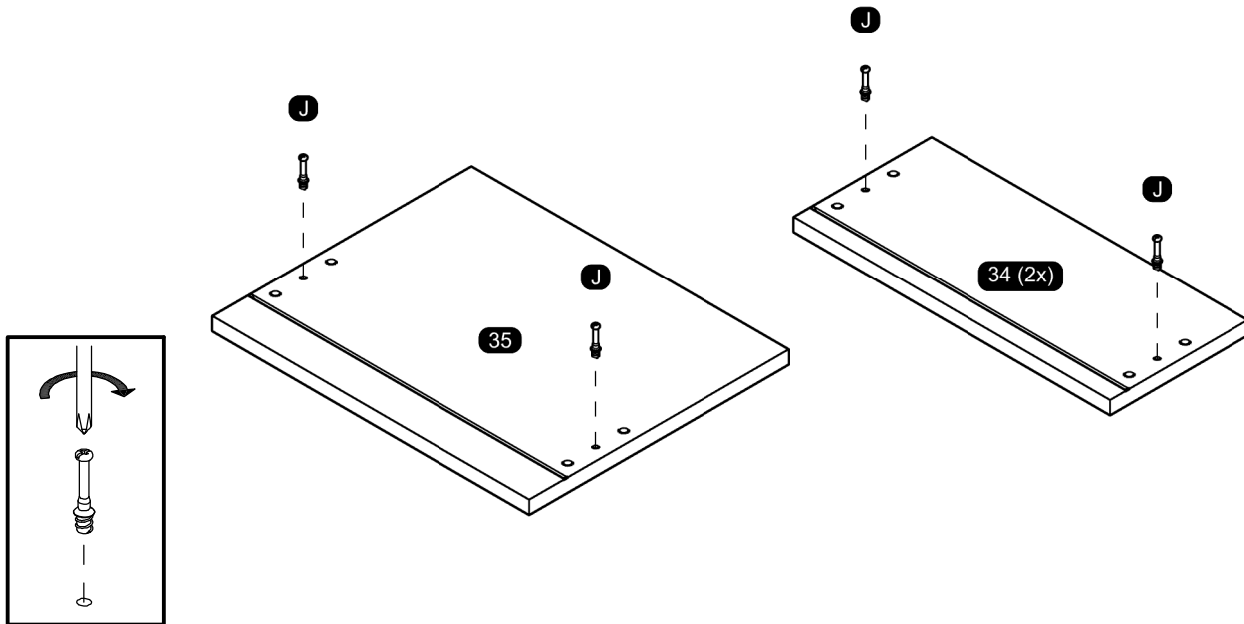

06

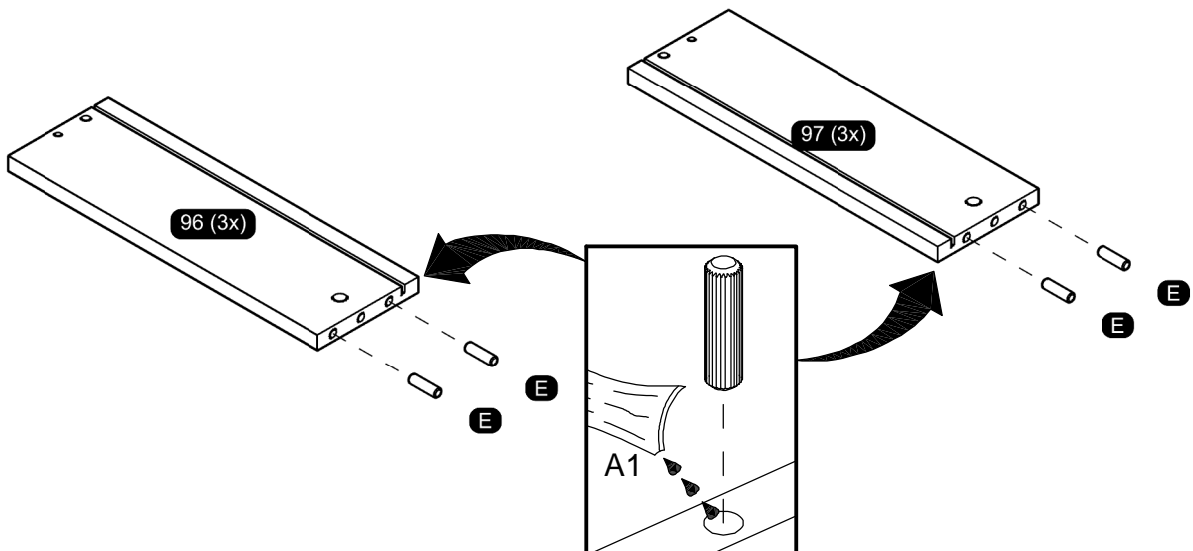

07

SEPARATE THE TWO PARTS OF THE METAL SLIDE TO THE ASSEMBLY FOLLOWING THE INSTRUCTIONS BELOW.
SEPARAR AS DUAS PARTES DA CORREDIÇA METÁLICA PARA A MONTAGEM SEGUINDO AS INSTRUÇÕES ABAIXO.
SEPARAR LAS DOS PARTES DE LA CORREDERA DE METAL PARA EL ARMADO Y SEGUIR LAS INSTRUCCIONES ABAJO.

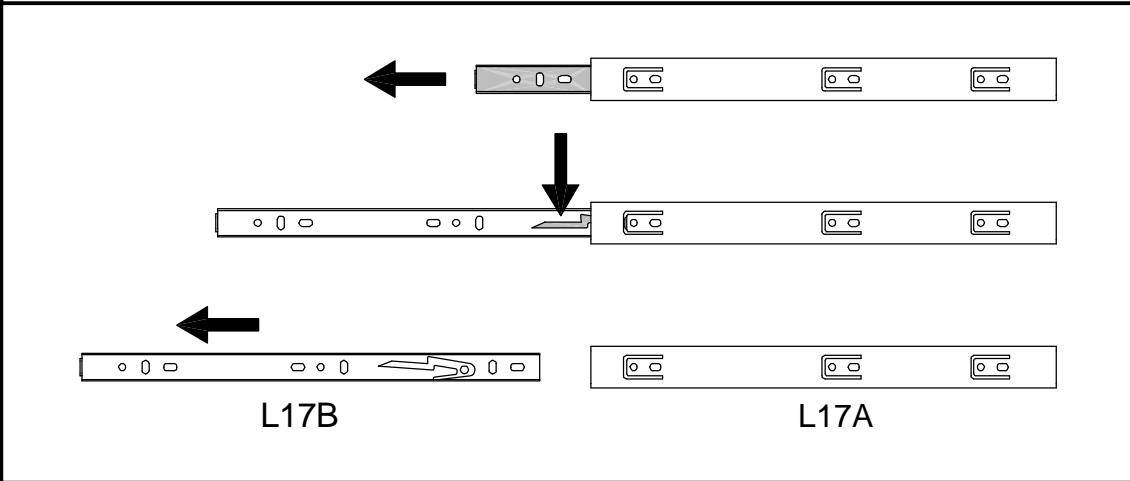

08

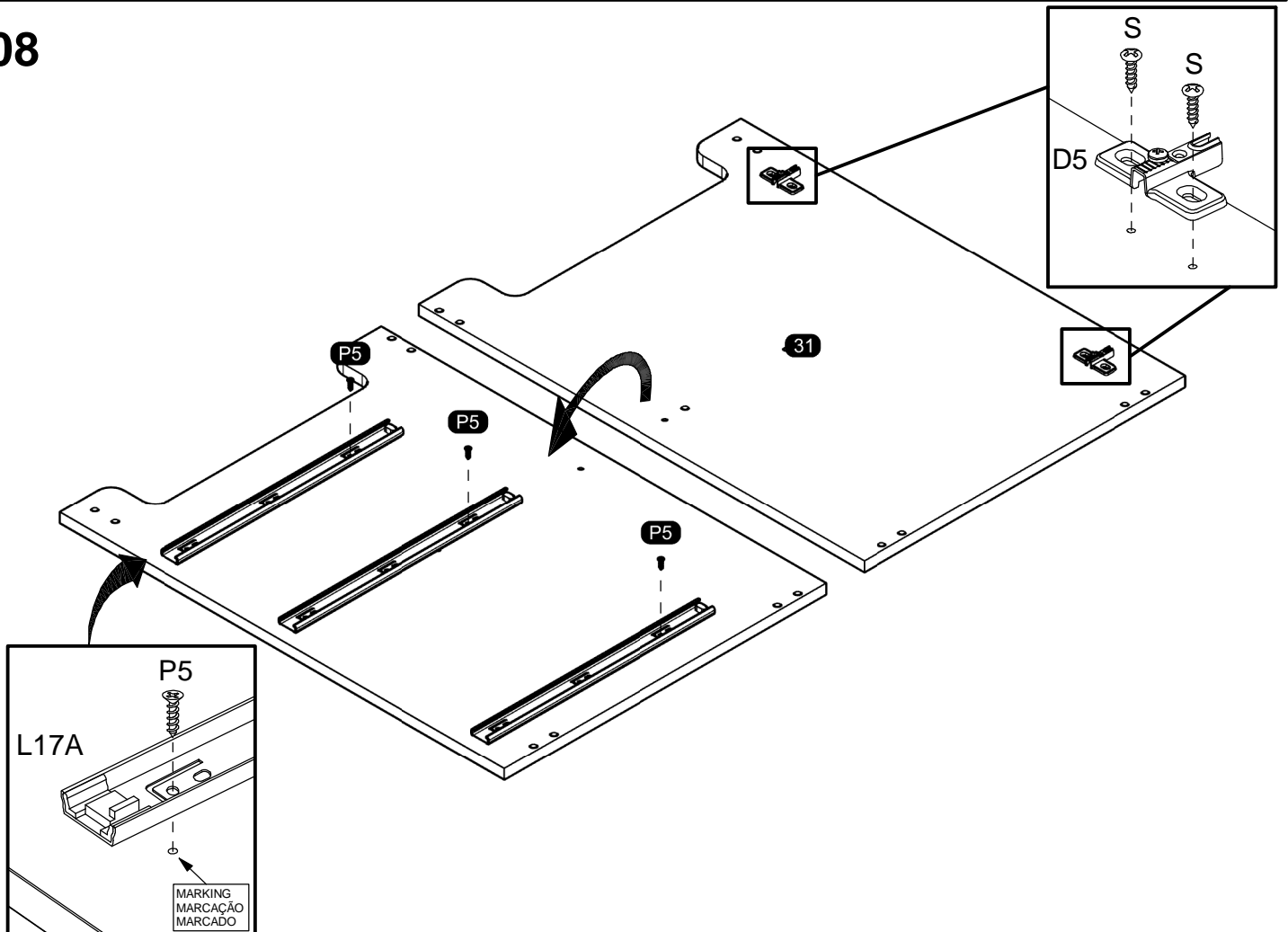

09

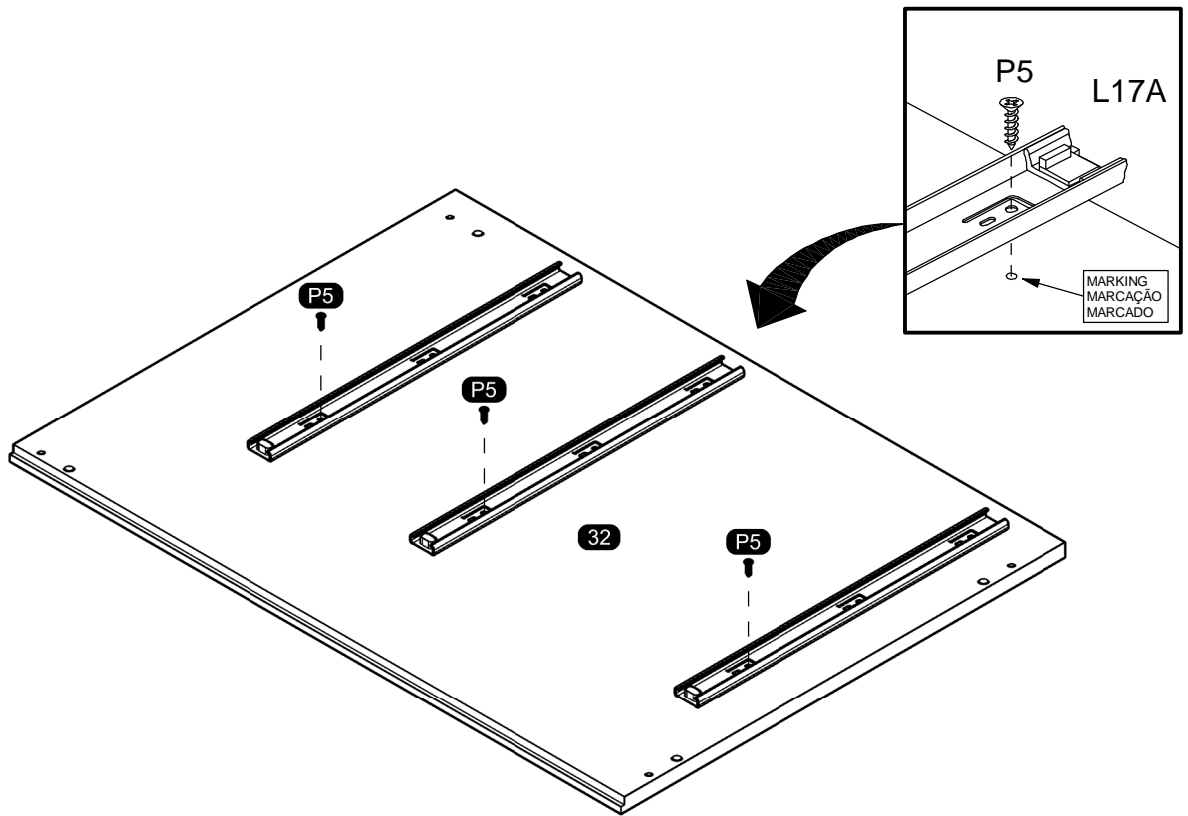

10

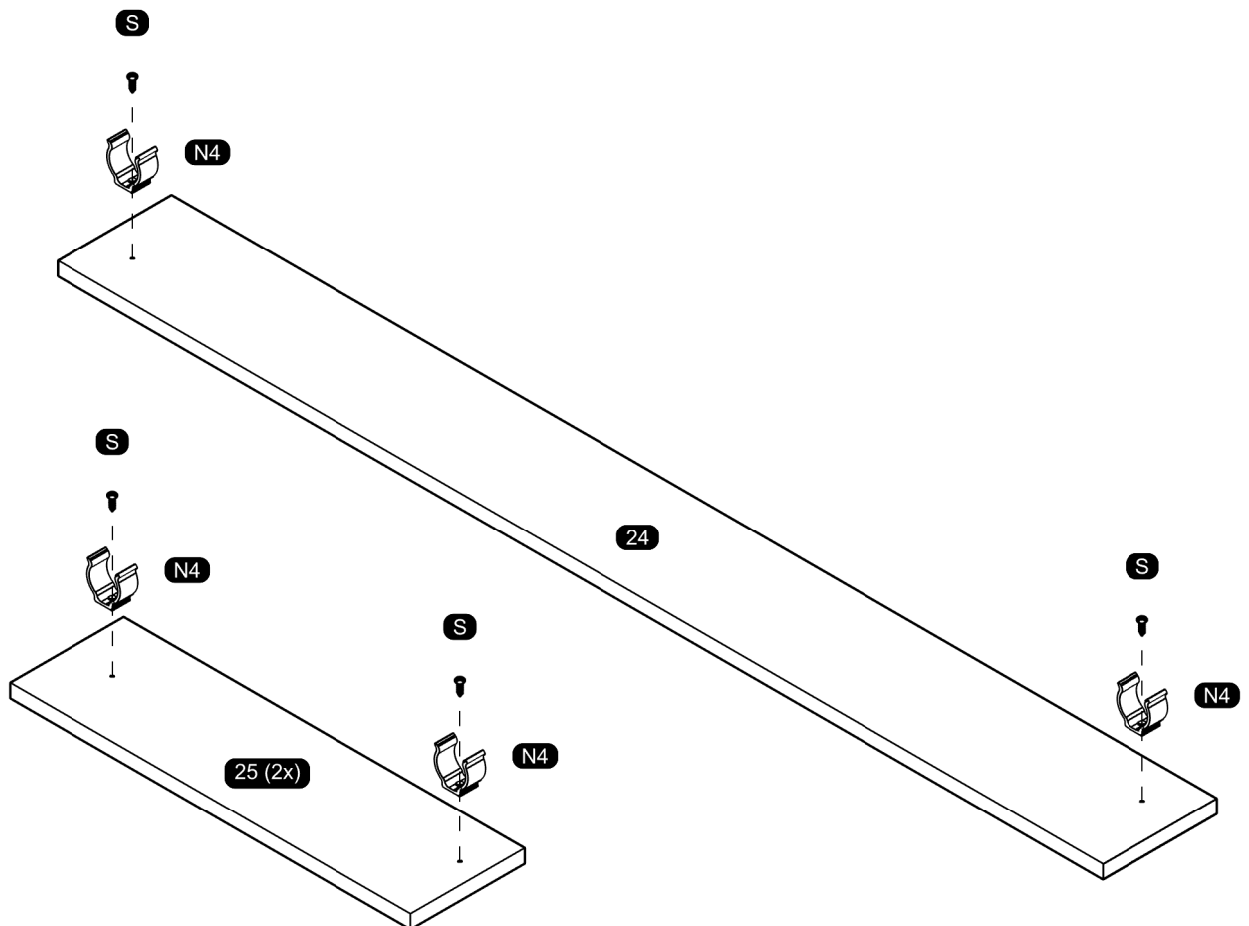

ASSEMBLY
MONTAGEM / ARMADO

11

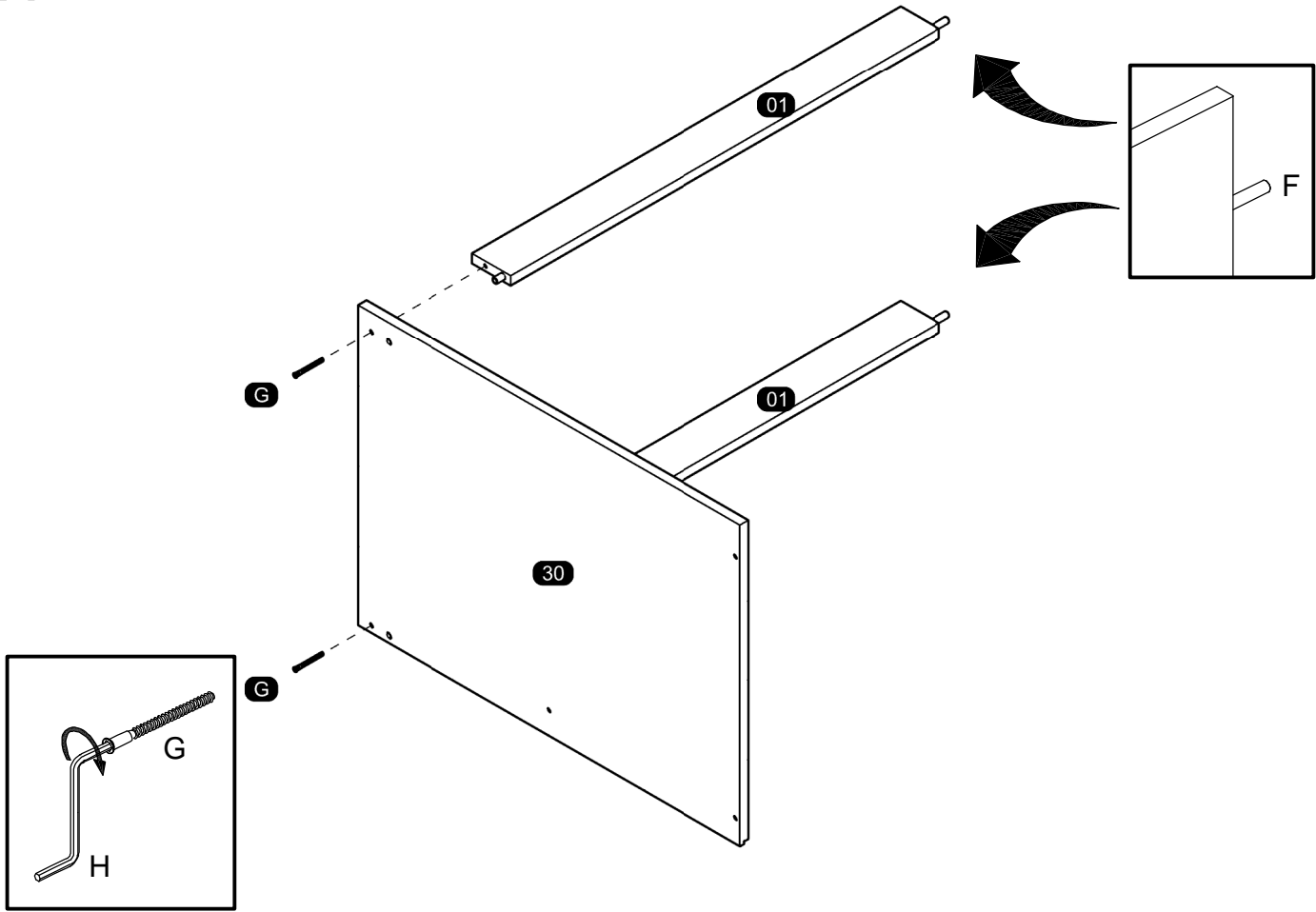

12

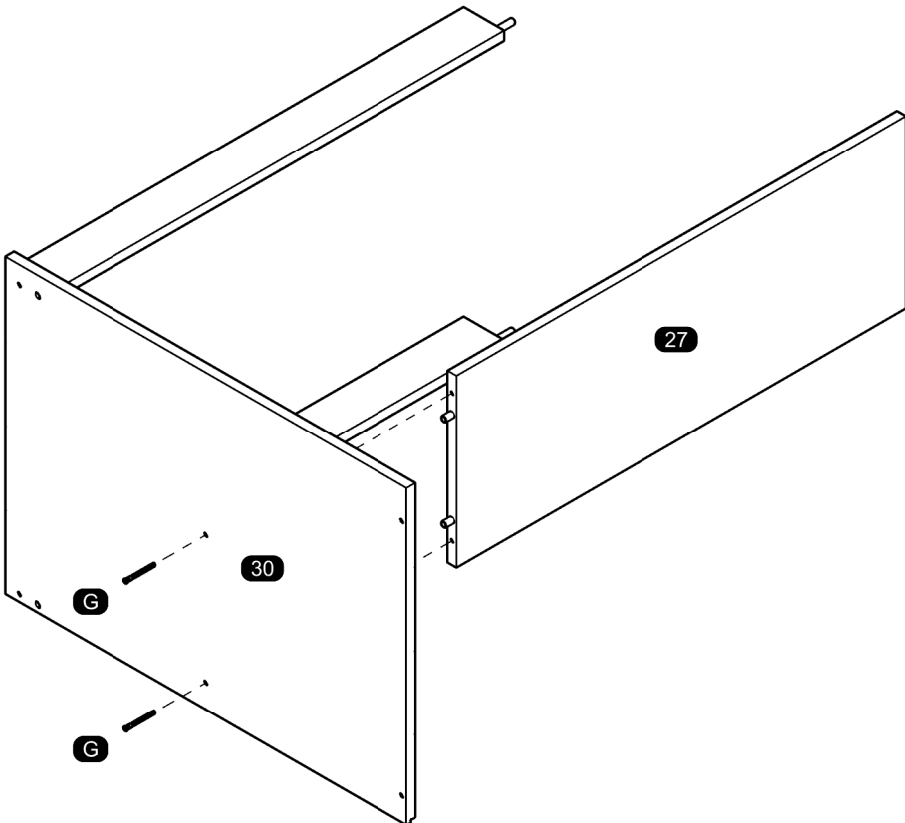

13

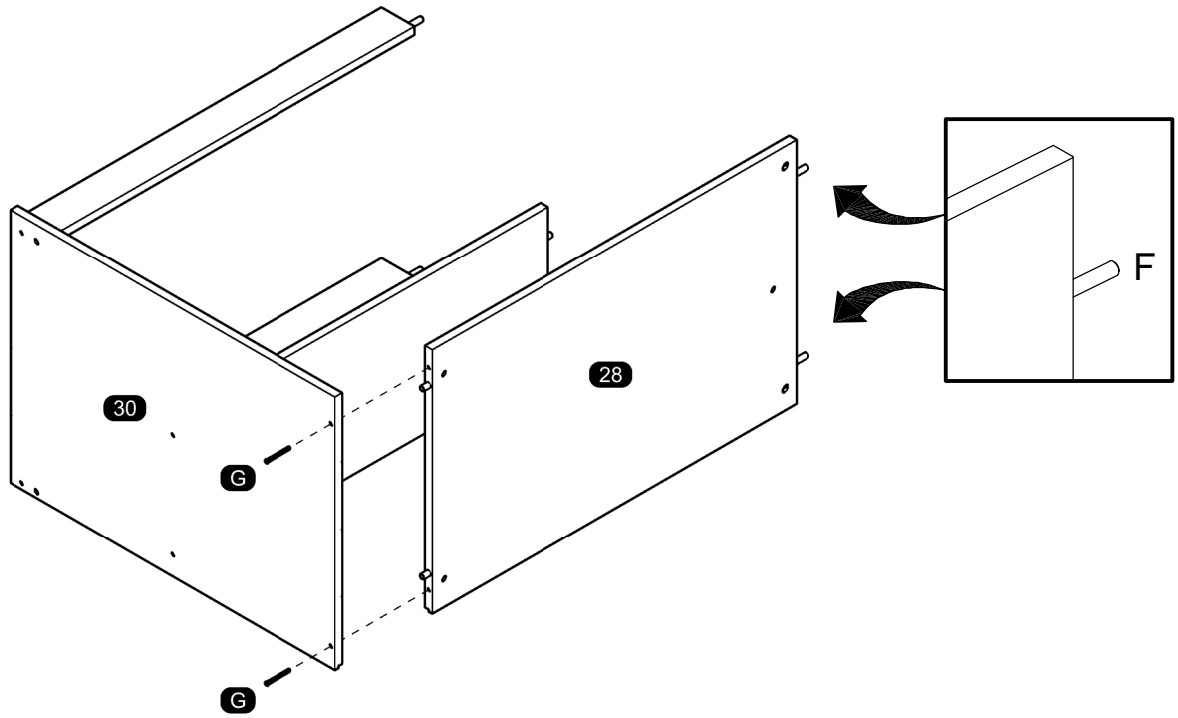

14

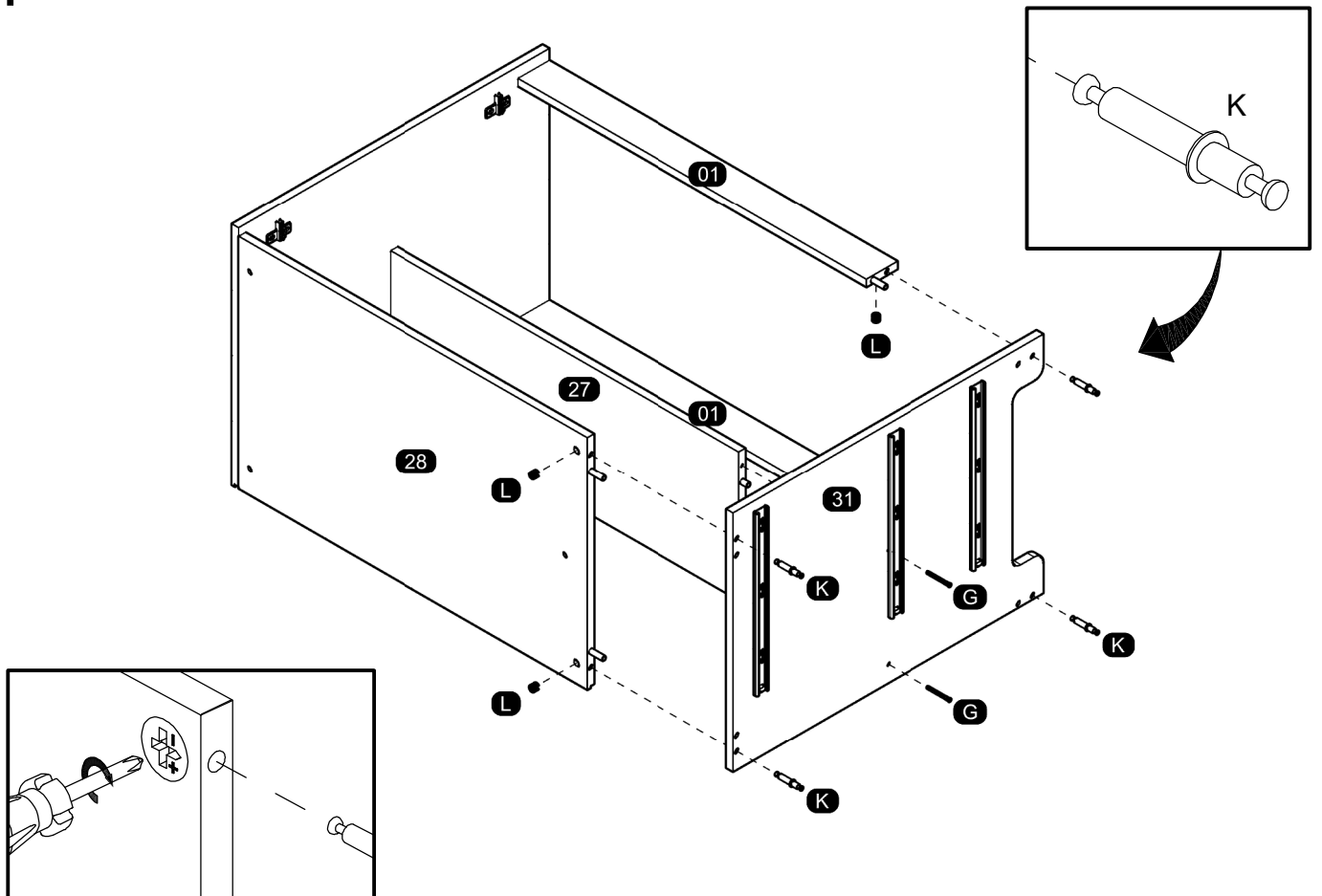

15

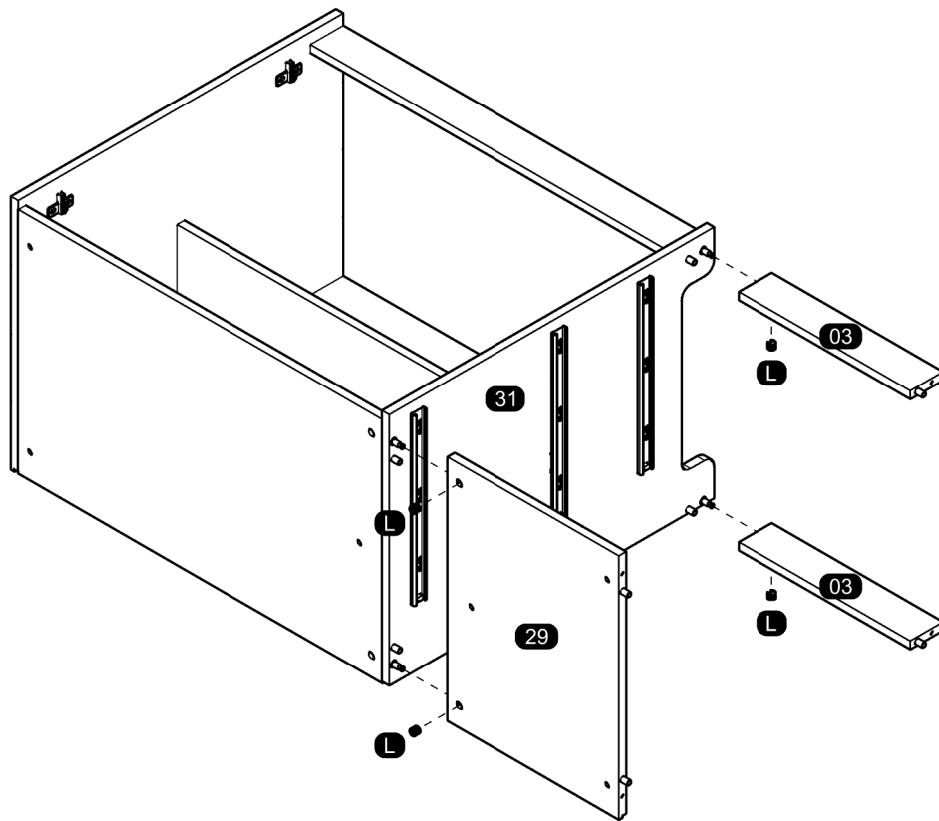

16

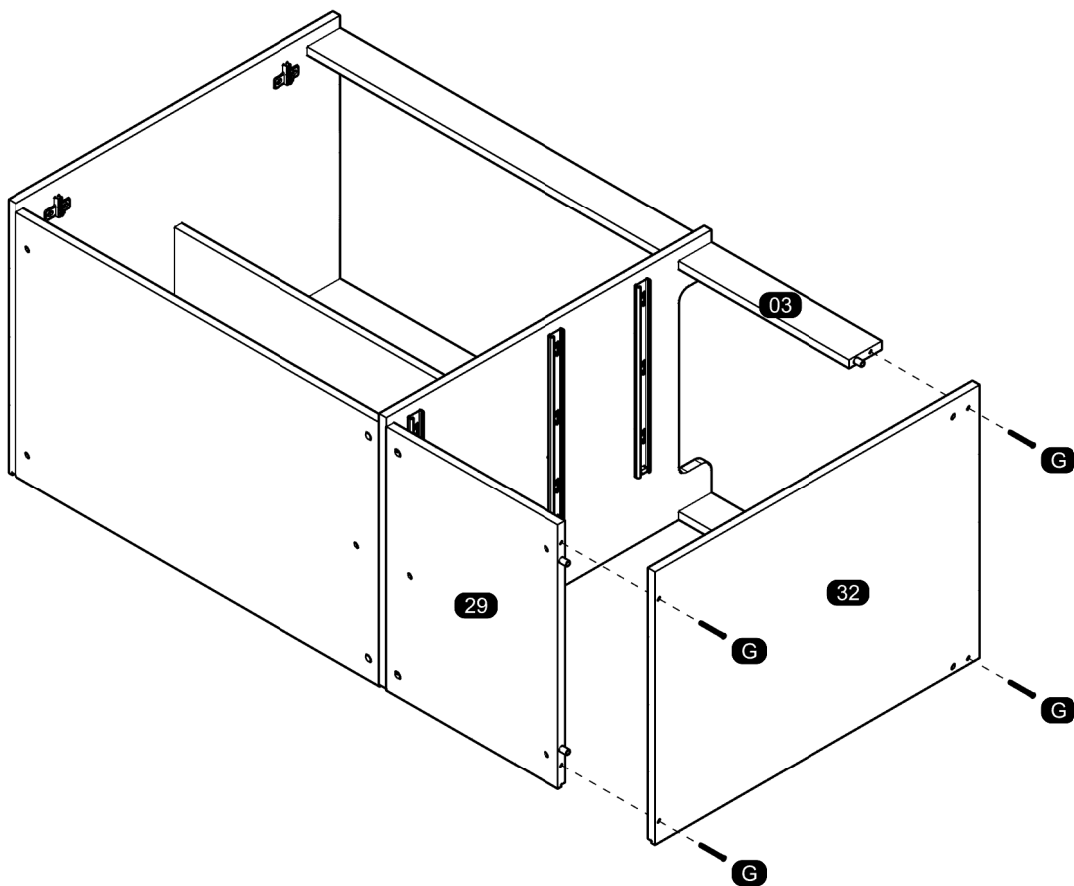

17

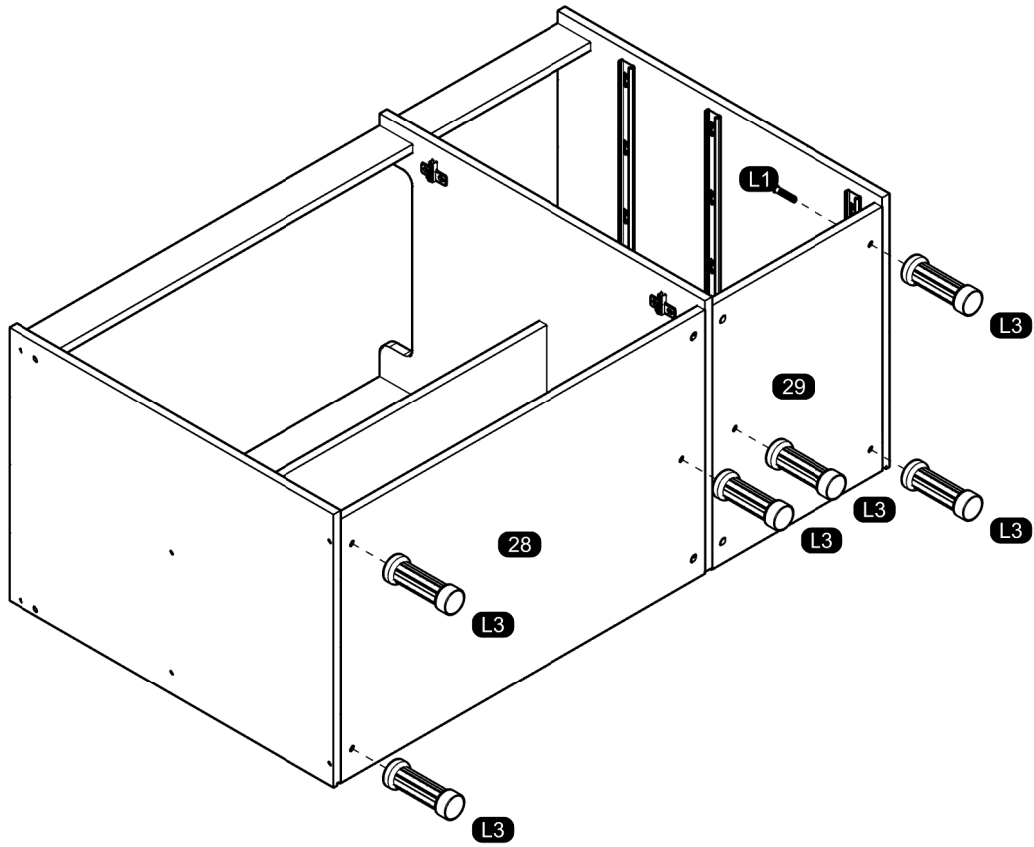

18

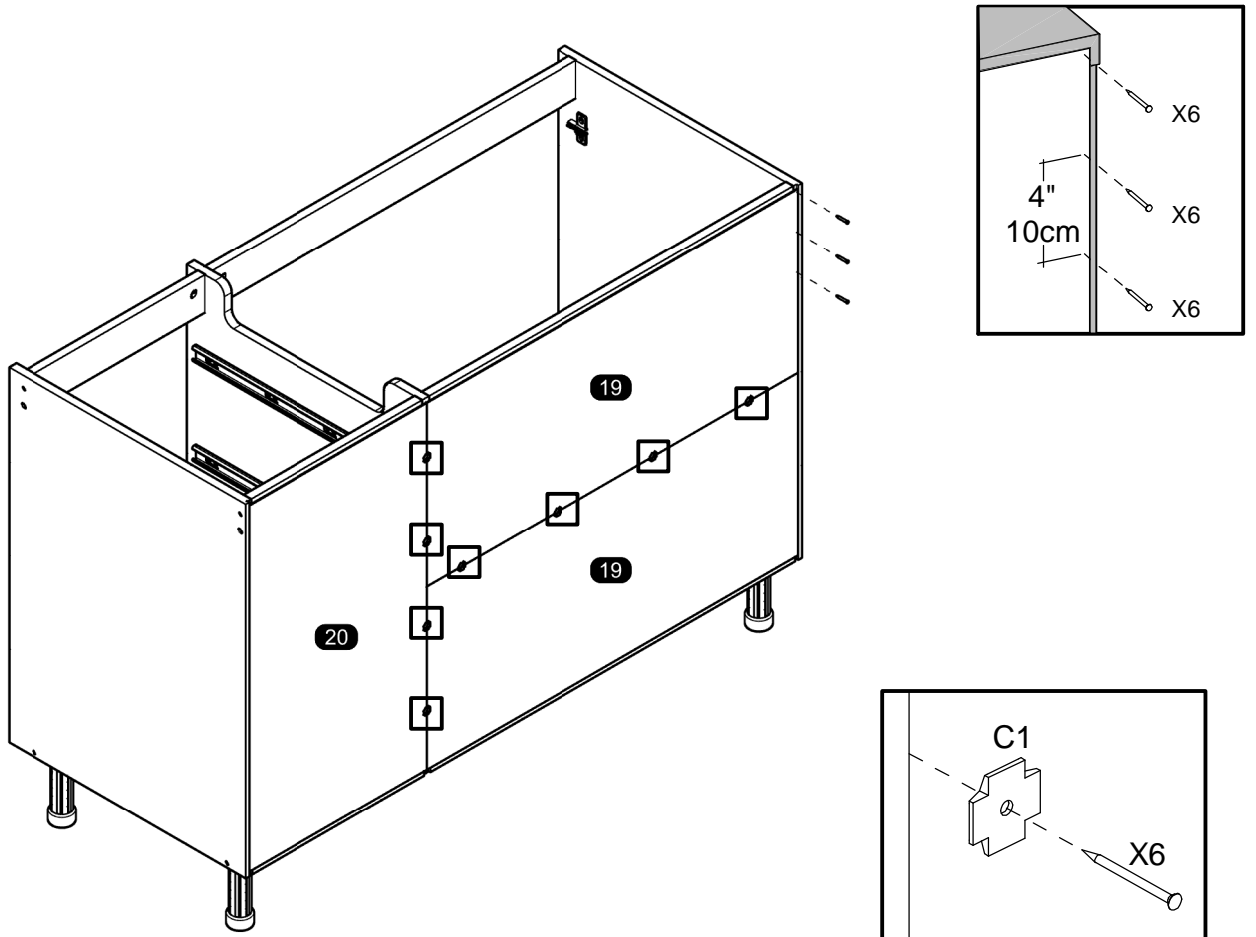

19

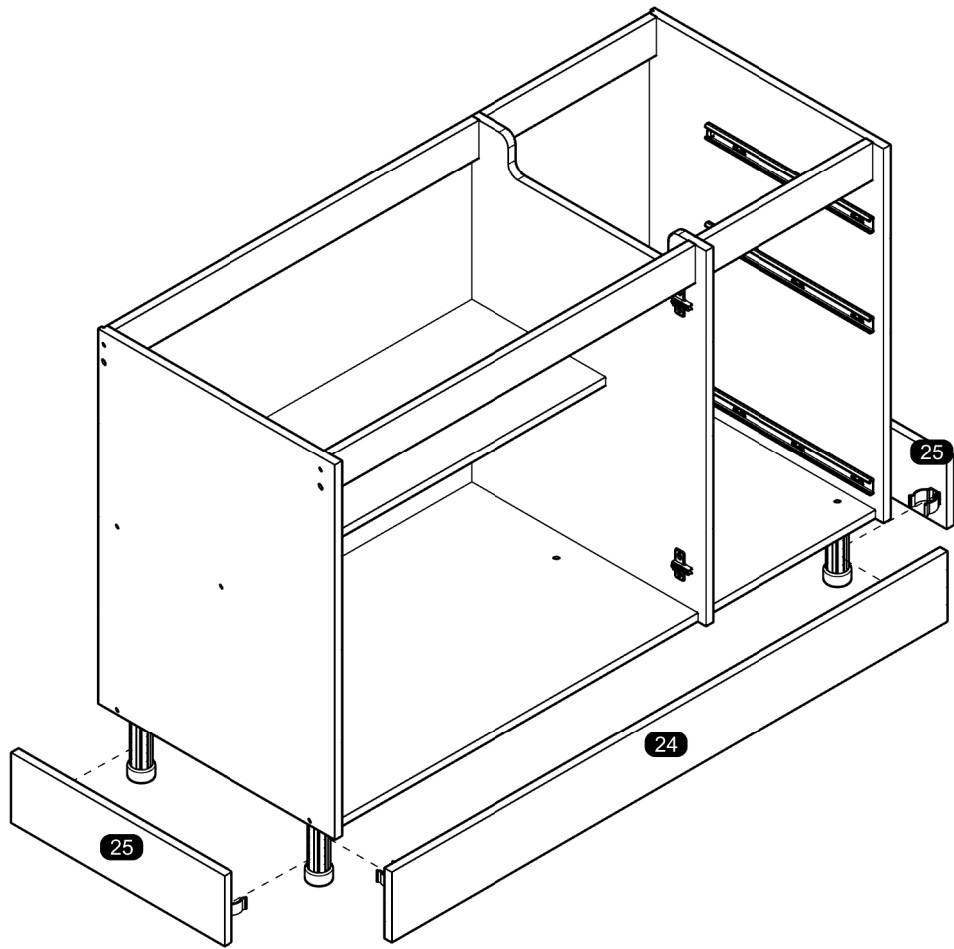

20

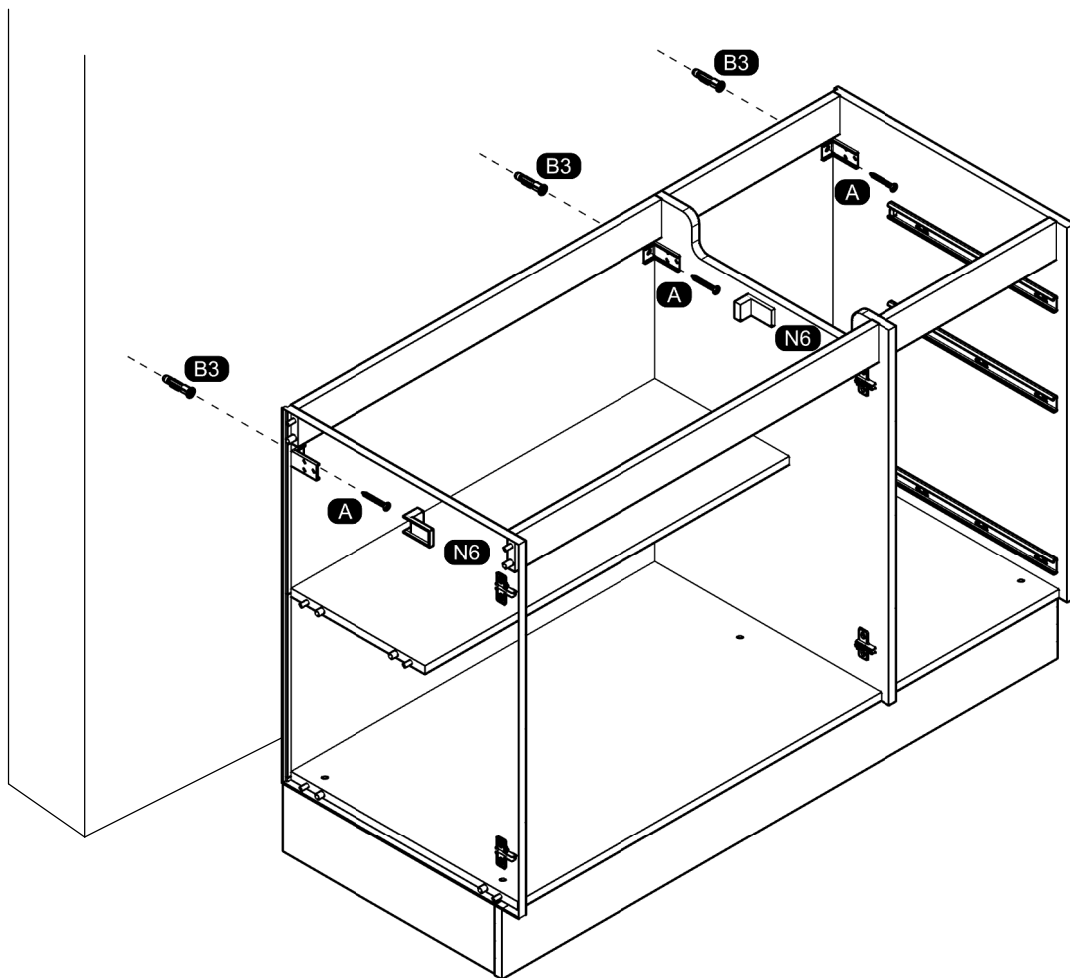

21

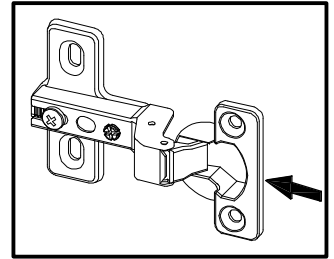
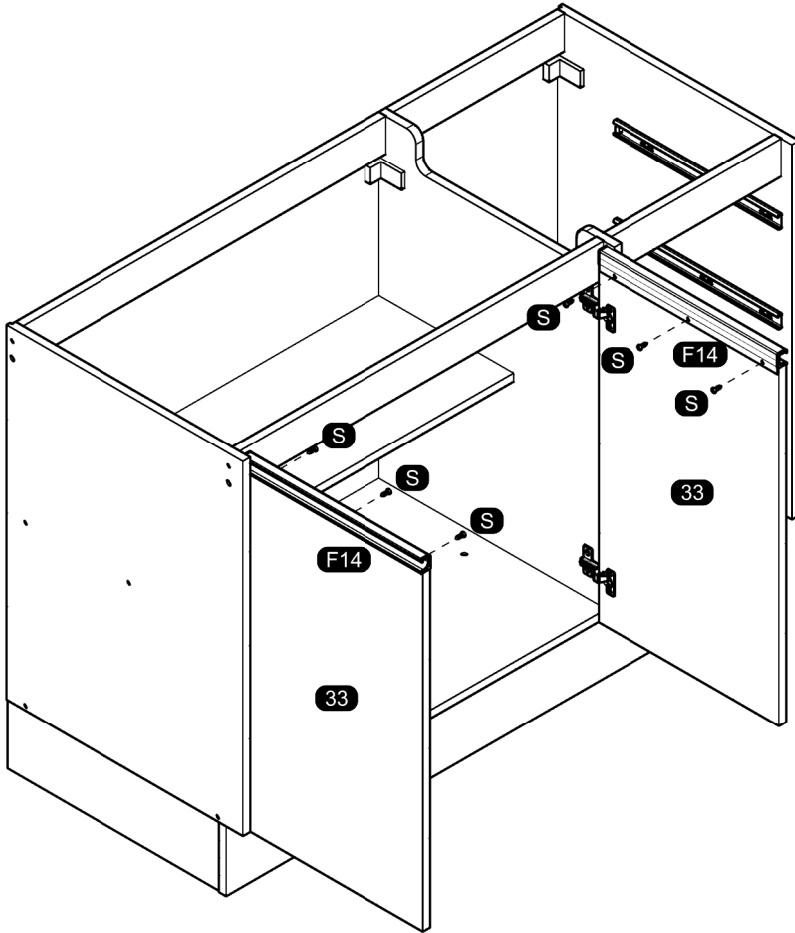

22

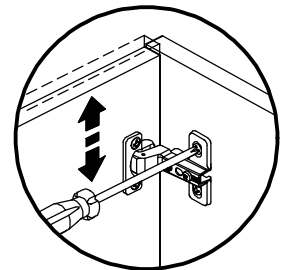
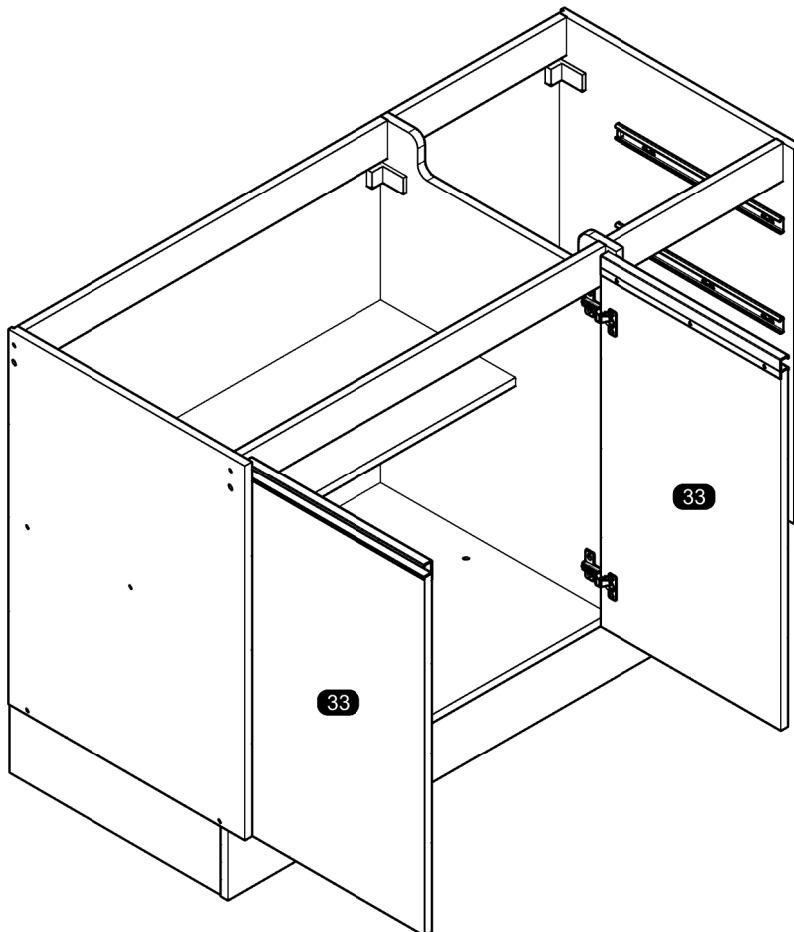

Regulagem Vertical

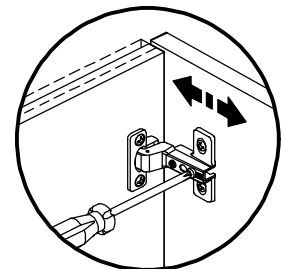

Regulagem Profundidade

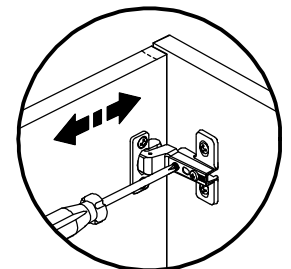

Regulagem Horizontal

23

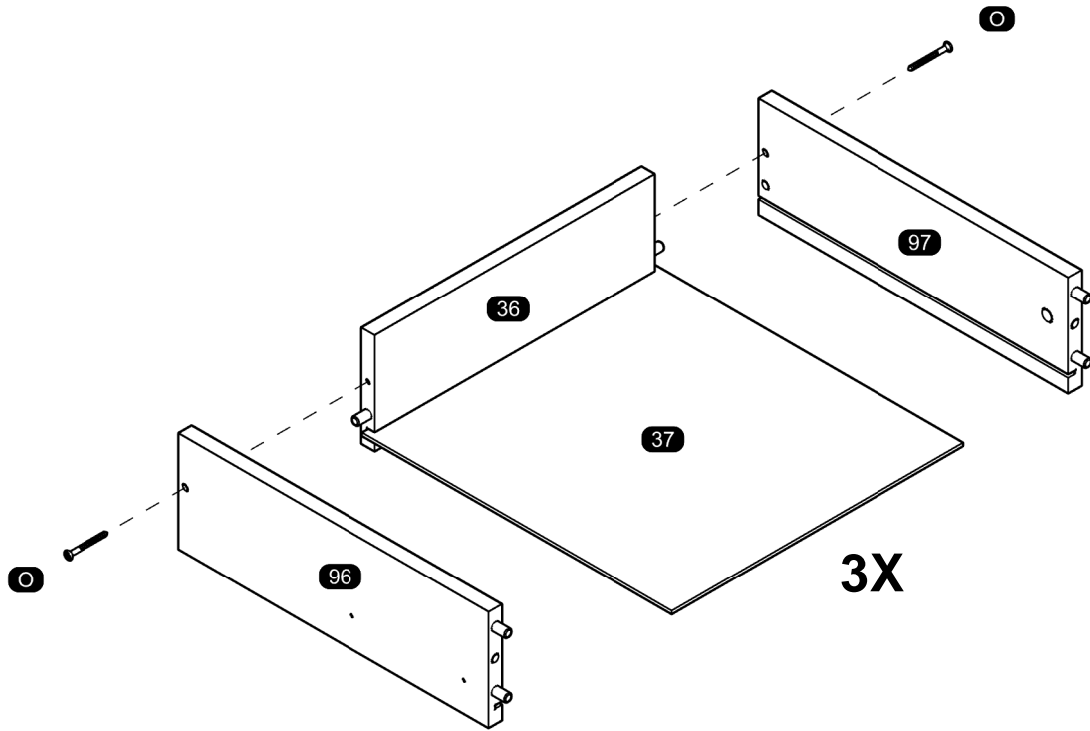

24

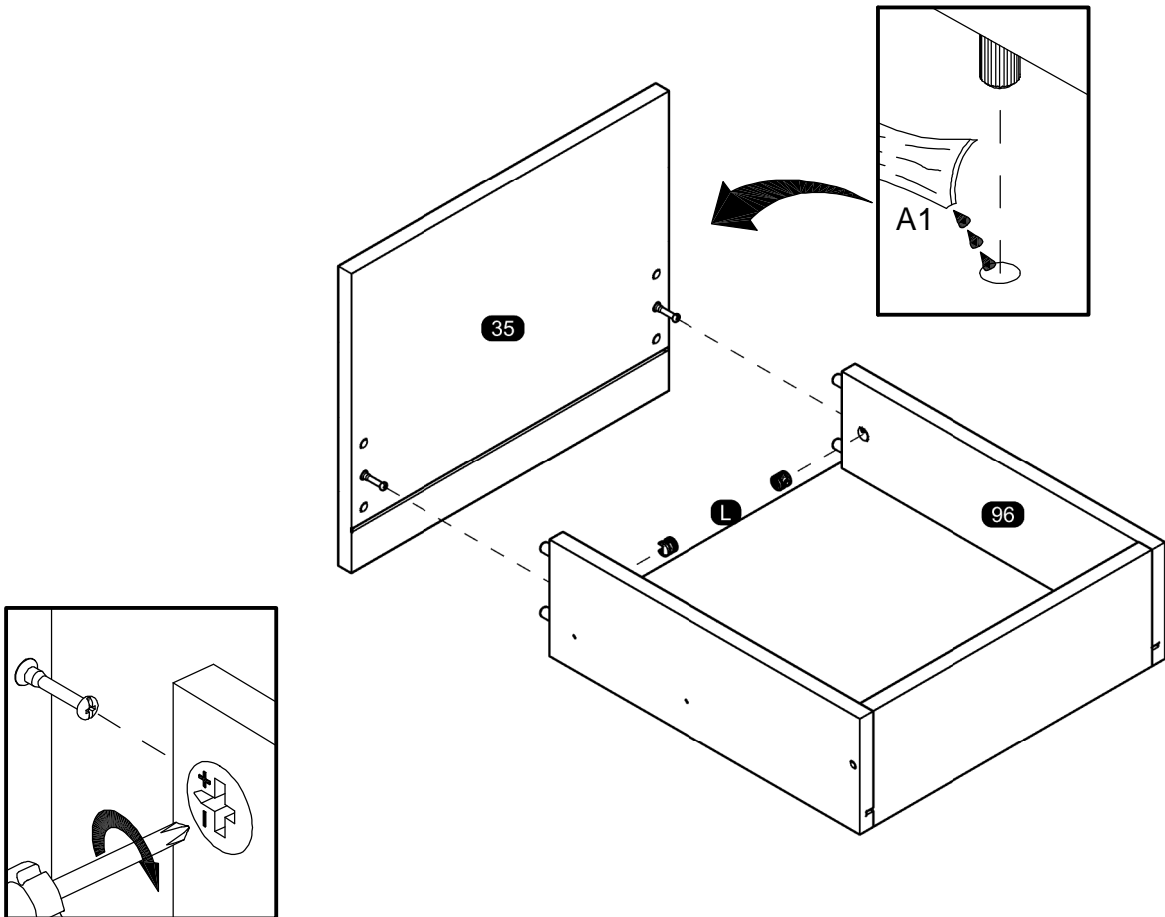

25

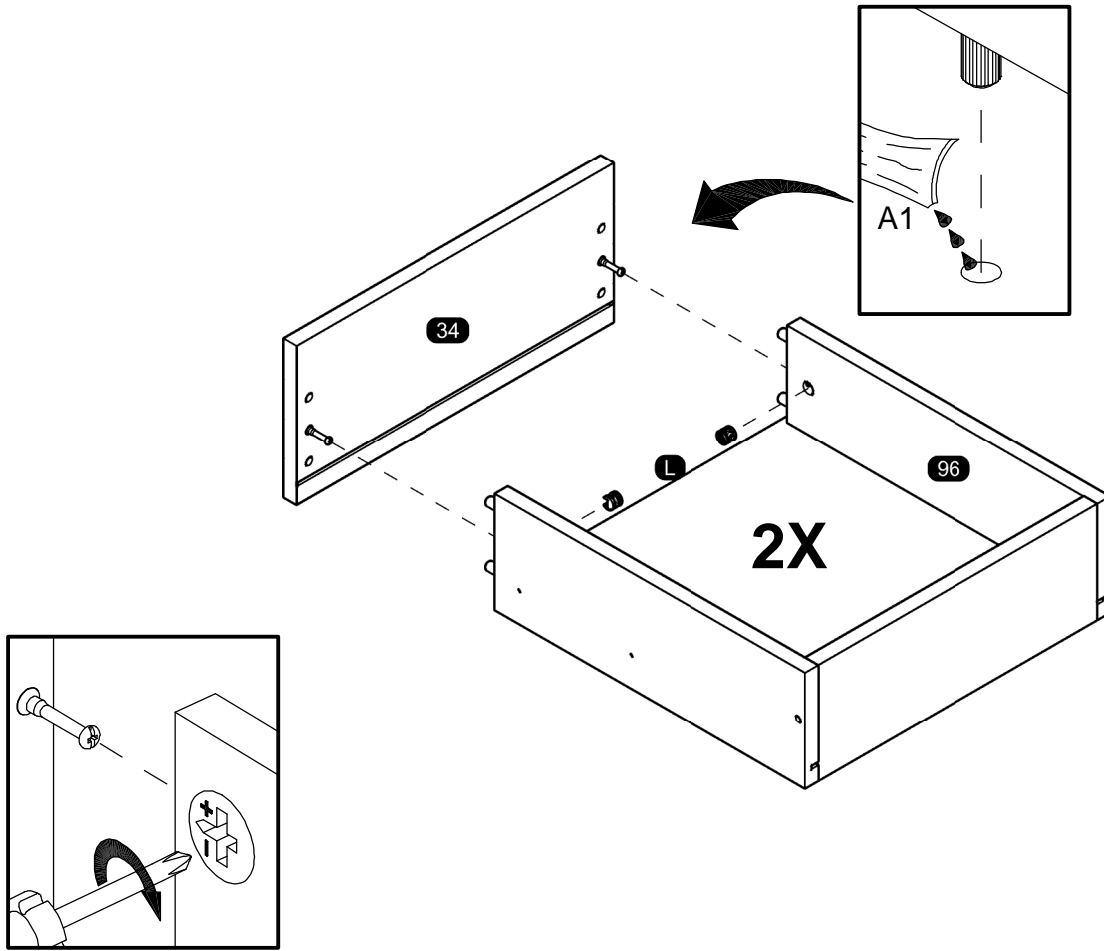

26

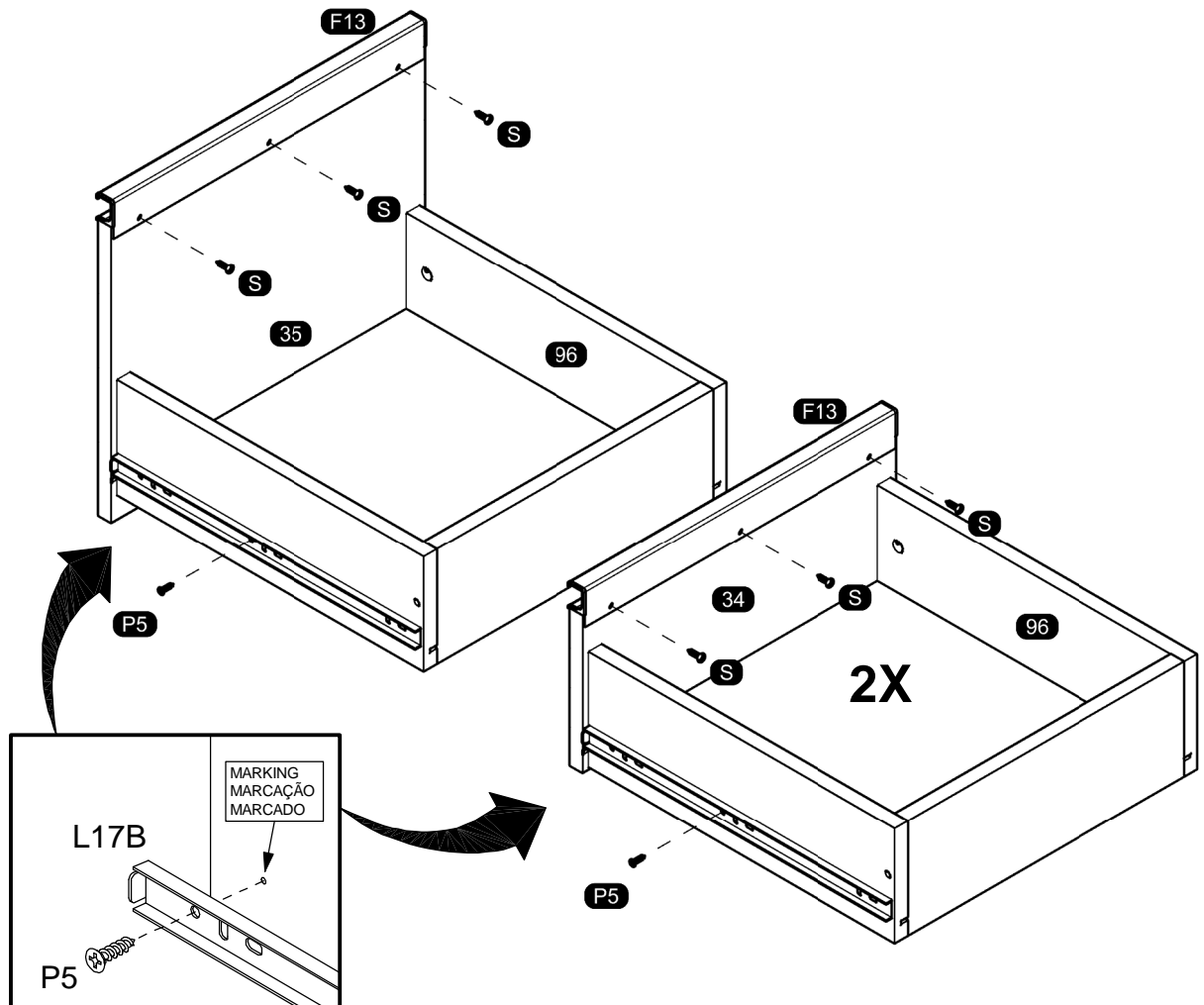

27

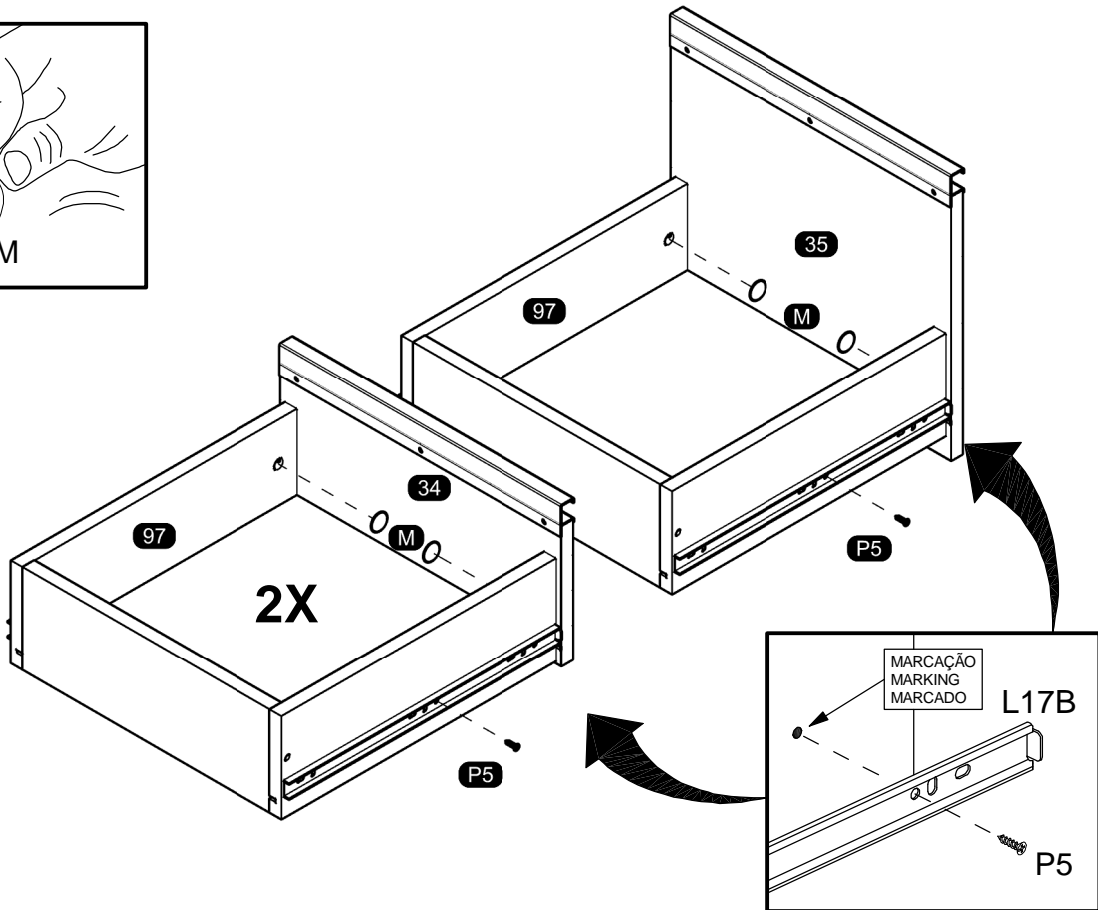
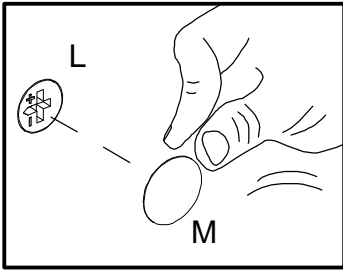

28

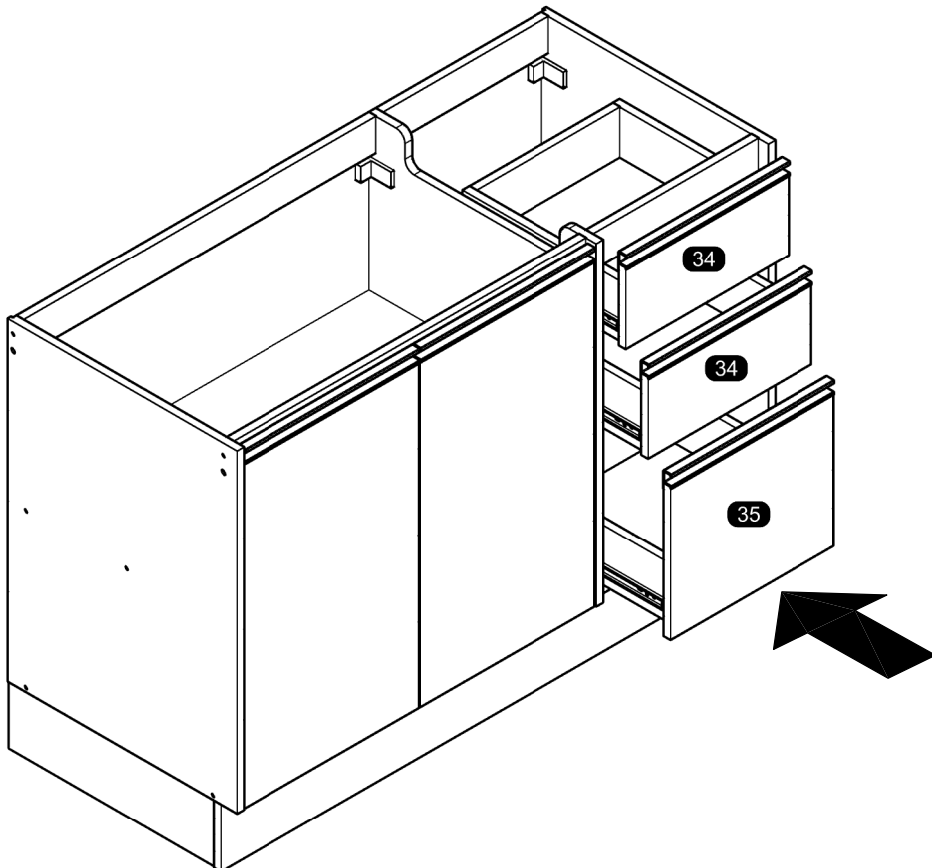

At the end of the assembly, insert the screw cover / hole plugs in the apparent holes.
Ao final da montagem, insira a(s) tampa(s) de parafuso / tapa furos nos furos que ficarem aparentes.
Al final del conjunto, coloque la tapa tornillo / tapón plástico en los agujeros que se hagan evidentes.

ASSEMBLY INSTRUCTIONS MANUAL DE MONTAGEM / INSTRUCCIONES DE ARMADO

CAMPANELE WALL CABINET 3 DOORS 45 1/4"
AÉREO 3 PORTAS 1200MM CAMPANELE
ARMARIO DE PAREDE 3 PUERTAS 1200MM CAMPANELE

Reference 200042 | Revise 02
Referência 200042 | Revisão 02
Referencia 200042 | Revisión 02

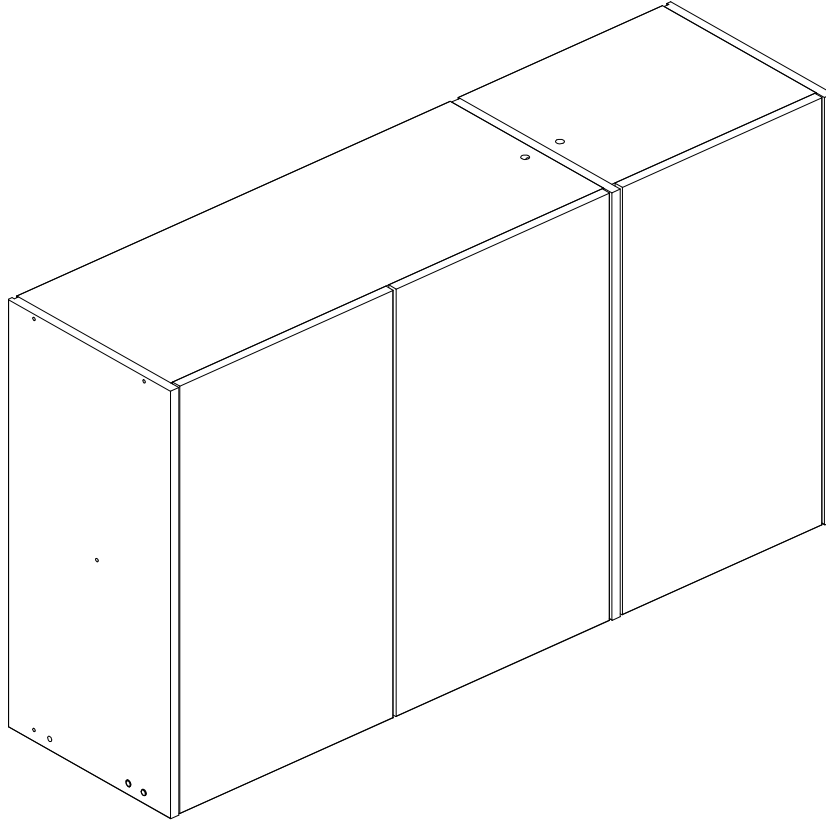

YOU WILL NEED / VOCÊ VAI PRECISAR DE / USTED NECESITARÁ

Tools not supplied / Ferramentas não fornecidas / Herramientas no incluidas

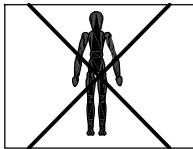

1 Person
1 Pessoa
1 Persona

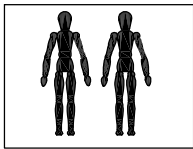

2 People
2 Pessoas
2 Personas

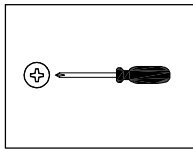

Screwdriver Phillips
Chave Phillips
Destornillador cruz

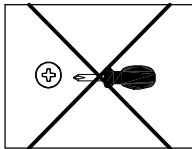

Small screwdriver Phillips
Chave Phillips Menor
Destornillador cruz menor

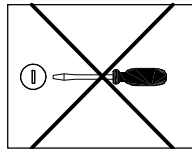

Screwdriver slotted
Chave fenda
Destornillador plano

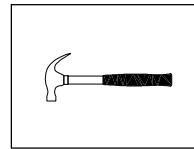

Hammer
Martelo
Martillo

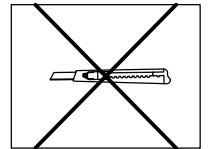

Styler
Estilete
Estilete

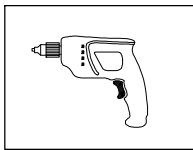

Drill machine
Furadeira
Taladro

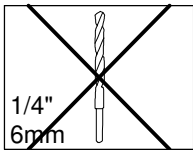

Drill bit
Broca
Taladro

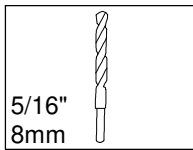

Drill bit
Broca
Taladro

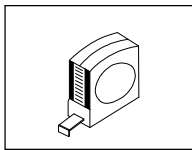

Measuring tape
Trena
Cinta de medición

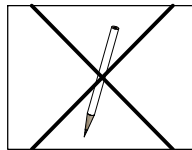

Pencil
Lápis
Lápis

NOTES: The separation of the accessories before you start the assembly will facilitate the same. In case of doubt on the size of the screws and bolts, use the ruler to bottom of page 3.

NOTAS: A separação dos acessórios antes de iniciar a montagem facilitará a mesma. Em caso de dúvida no tamanho dos parafusos e cavilhas, utilize a régua ao final da página 3.

NOTAS: La separación de los accesorios antes de comenzar el armado facilitará el mismo. En caso de duda sobre el tamaño de los tornillos y taquetes, utilice la regla al pie de página 3.

MAXIMUM RECOMMENDED WEIGHT
BEING THIS EVENLY DISTRIBUTED

PESO MÁXIMO RECOMENDADO SENDO
ESTE DISTRIBUÍDO UNIFORMEMENTE

PESO MÁXIMO RECOMENDADO SIENDO
ESTE UNIFORMEMENTE DISTRIBUIDO

| | LB | KG |
|----------|----|----|
| A | 22 | 10 |
| B | 11 | 5 |

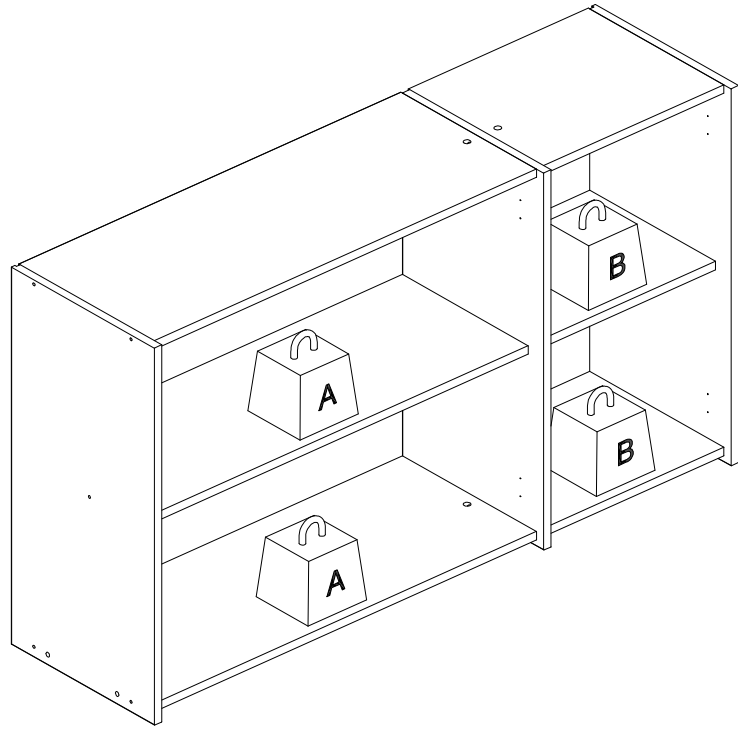





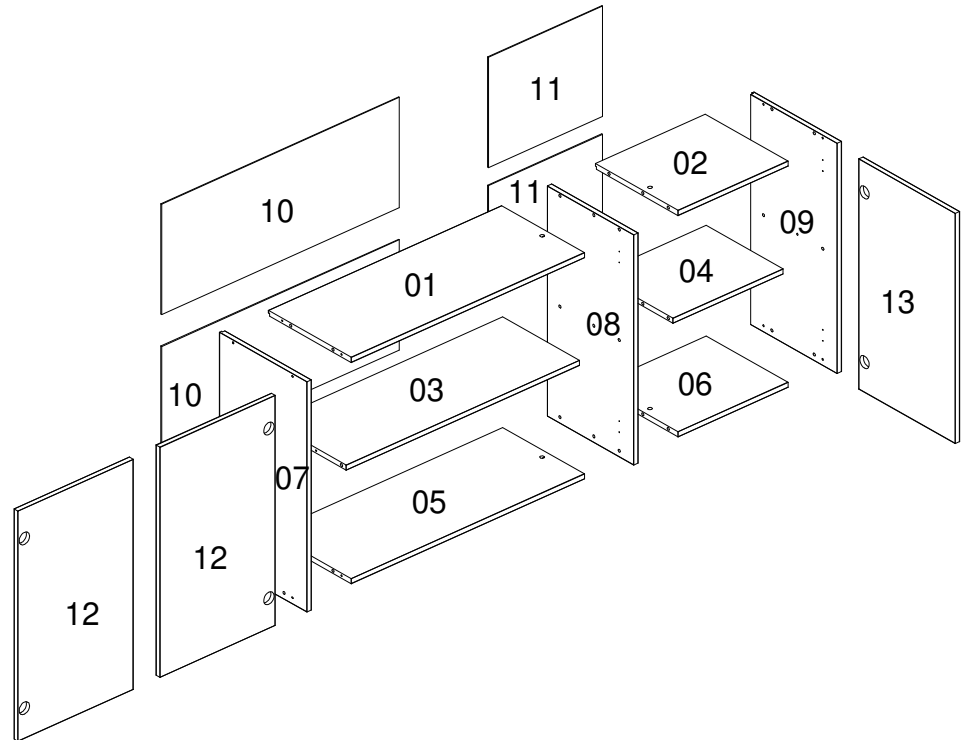



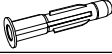



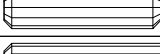
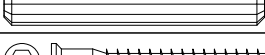
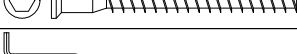

| Nº | Measures Inches | Medidas cm | Qty./Qtd. |
|----|-----------------------|-------------------|-----------|
| 01 | 30 7/8 x 12 3/8 x 5/8 | 78,5 x 31,3 x 1,5 | 1 |
| 02 | 14 5/8 x 12 3/8 x 5/8 | 37 x 31,3 x 1,5 | 1 |
| 03 | 30 7/8 x 11 3/8 x 5/8 | 78,5 x 29 x 1,5 | 1 |
| 04 | 14 5/8 x 11 3/8 x 5/8 | 37 x 29 x 1,5 | 1 |
| 05 | 30 7/8 x 12 3/8 x 5/8 | 78,5 x 31,3 x 1,5 | 1 |
| 06 | 14 5/8 x 12 3/8 x 5/8 | 37 x 31,3 x 1,5 | 1 |
| 07 | 26 3/8 x 13 x 5/8 | 67 x 33 x 1,5 | 1 |
| 08 | 26 3/8 x 12 7/8 x 5/8 | 67 x 32,6 x 1,5 | 1 |
| 09 | 26 3/8 x 13 x 5/8 | 67 x 33 x 1,5 | 1 |
| 10 | 31 1/2 x 12 5/8 x 1/8 | 80 x 32,1 x 0,3 | 2 |
| 11 | 15 1/8 x 12 5/8 x 1/8 | 38,4 x 32,1 x 0,3 | 2 |
| 12 | 15 1/4 x 26 3/8 x 5/8 | 38,8 x 67 x 1,5 | 2 |
| 13 | 14 1/4 x 26 3/8 x 5/8 | 36,4 x 67 x 1,5 | 1 |

PARTS IDENTIFICATION
IDENTIFICAÇÃO DAS PEÇAS / IDENTIFICACIÓN DE LAS PIEZAS



IDENTIFICATION OF ACCESSORIES IDENTIFICAÇÃO DOS ACESSÓRIOS/ IDENTIFICACIÓN DE ACCESORIOS

| | | | | |
|----|---|--|-----------|----|
| A |  | Flanged head screw / Parafuso flangeado / Tornillo de cabeza flangeada | 5,0x60 mm | 3 |
| B3 |  | Bushing / Bucha expansiva / Tapón | 8x50 mm | 3 |
| C1 |  | Metal claw / Garra de metal / Garra metal | - | 10 |
| D5 |  | Hinge shim / Calço dobradiça / Bisagra de calce | - | 6 |
| D6 |  | Metal hinge super high / Dobradiça super alta / Bisagra alta | 26 mm | 6 |
| E |  | Wooden dowel / Cavilha / Taquete | 8x30 mm | 12 |
| F |  | Wooden dowel / Cavilha / Taquete | 8x50 mm | 6 |
| G |  | Structural screw / Parafuso estrutural / Tornillo estructural | 5,0x50 mm | 10 |
| H |  | Allen key / Chave allen / Liave allen | 3 mm | 1 |
| I |  | Structural screw cover/Tampa parafuso estrutural/Tapa tornillo estructural | - | 10 |
| K |  | Double minifix screw / Haste minifix dupla / Tornillo minifix doble | 60mm | 3 |
| L |  | Drum lock / Tambor minifix / Tambor minifix | 12 mm | 6 |
| M |  | Bore patch adhesive / Tapa furo adesivo / Tapones adhesivo | - | 4 |
| N |  | Nail / Prego / Clavo | 10x10 | 46 |
| N5 |  | Support "L" / Suporte "L" / Soporte "L" | - | 3 |
| N6 |  | Cover / Capa / Cubierta | - | 3 |
| S |  | Pan head screw / Parafuso panela / Tornillo de pan | 3,5x14 mm | 30 |
| Z |  | Plastic hole plugs / Tapa furo plástico / Tapones plásticos | 8 mm | 4 |



PRE-ASSEMBLE
PRÉ-MONTAGE / PRE ARMADO

01

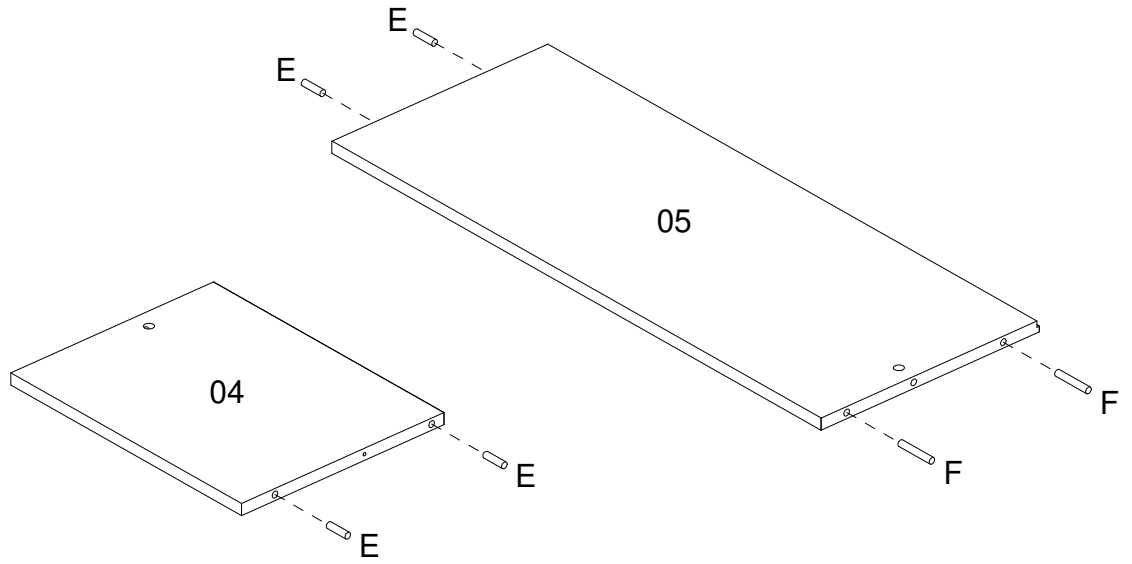
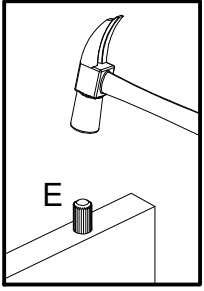

02

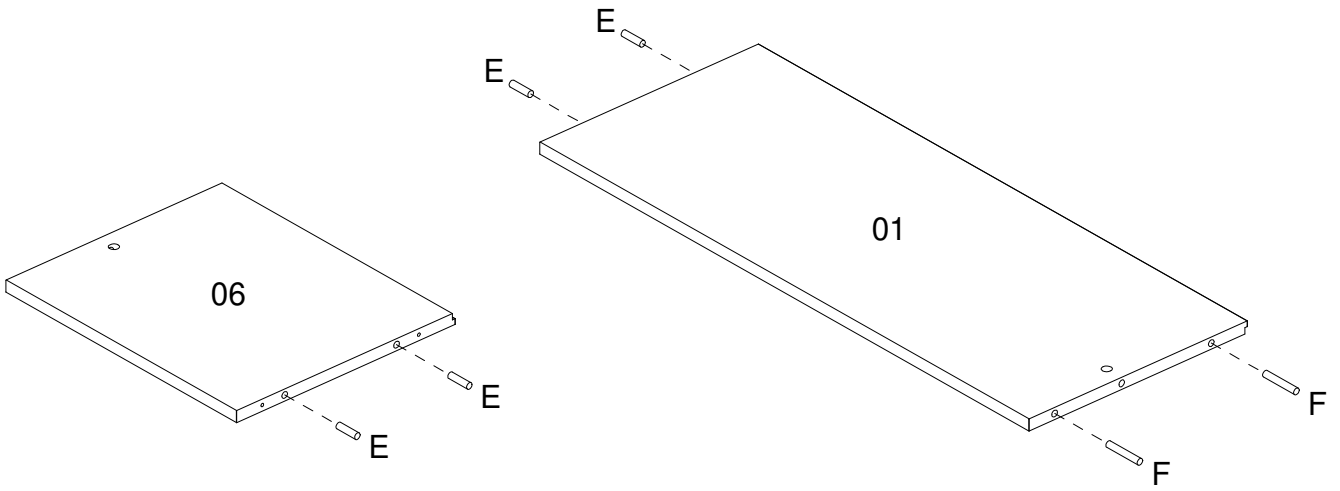

03

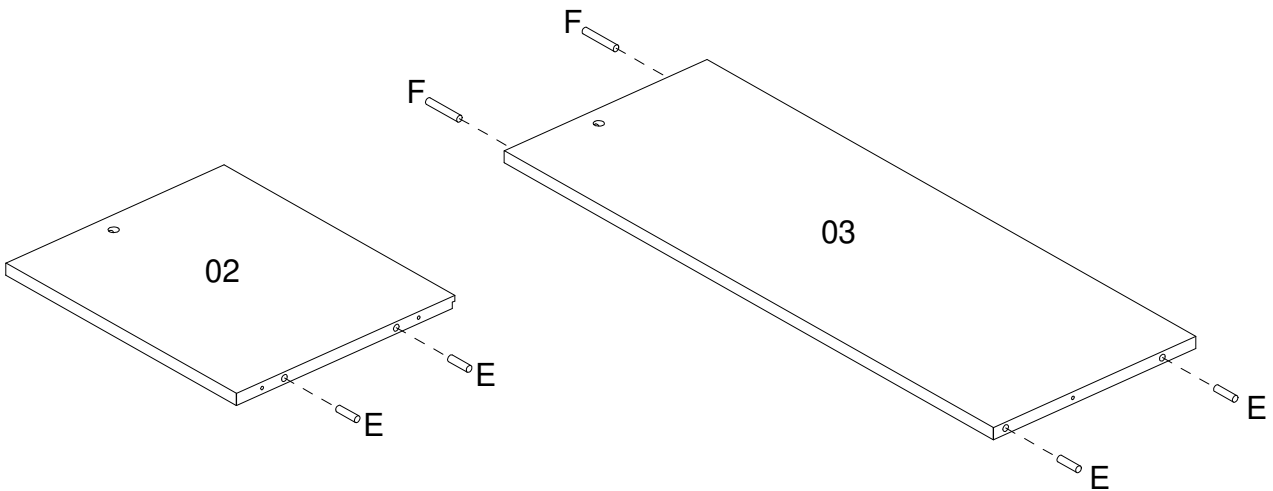

04

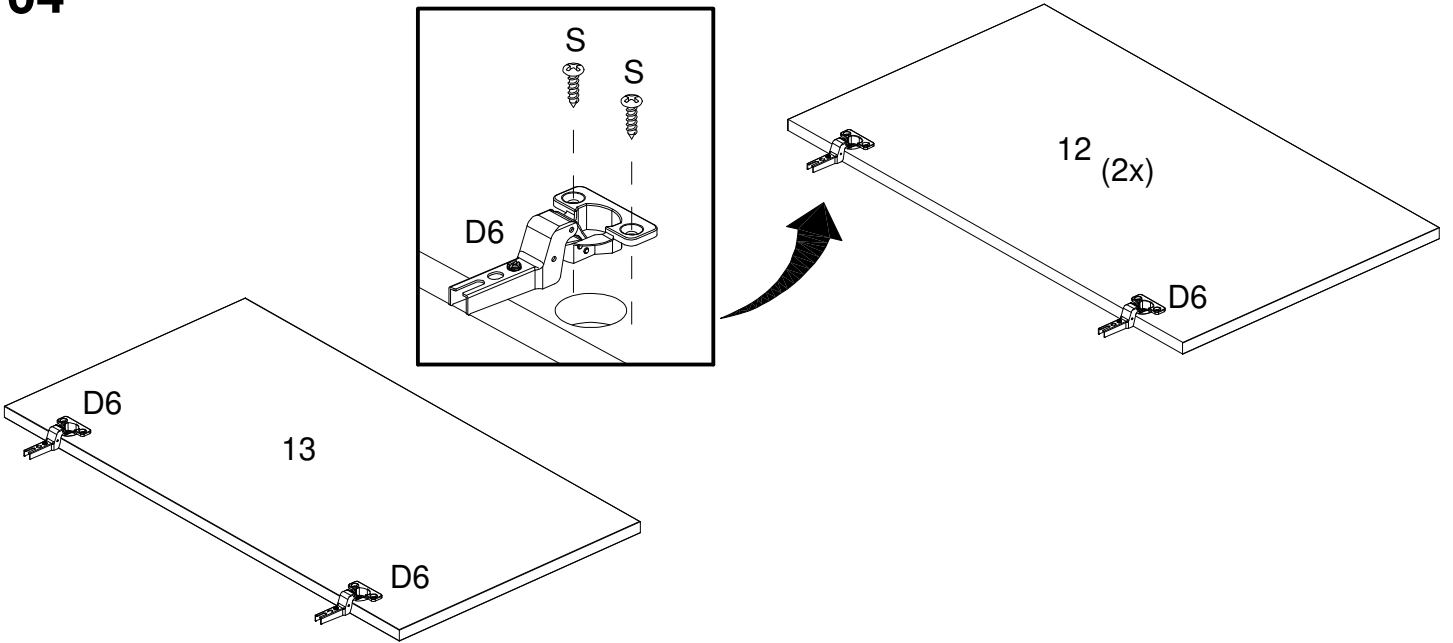

05

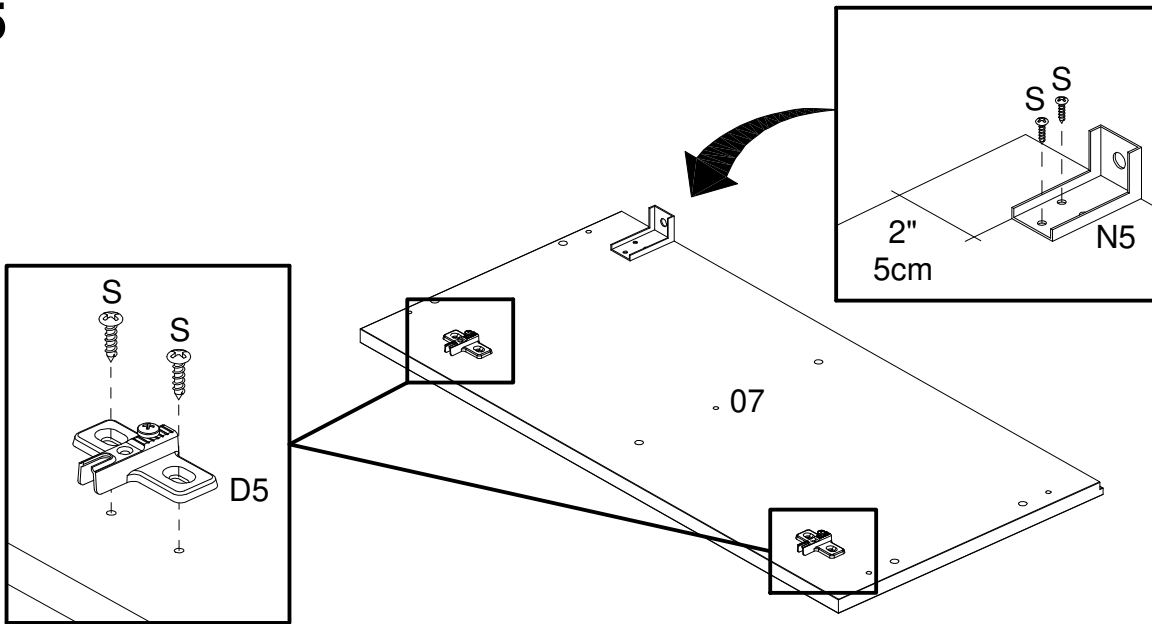

06

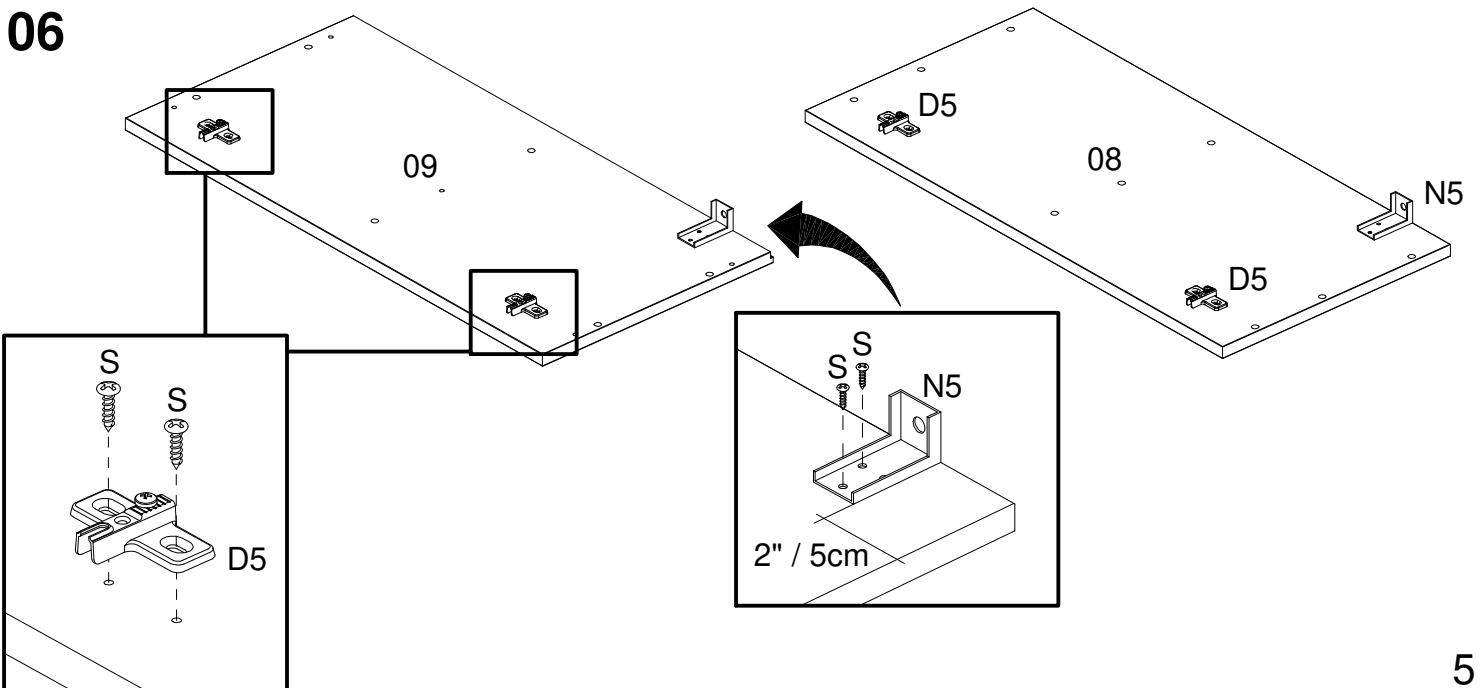

ASSEMBLY
MONTAGEM / ARMADO

07

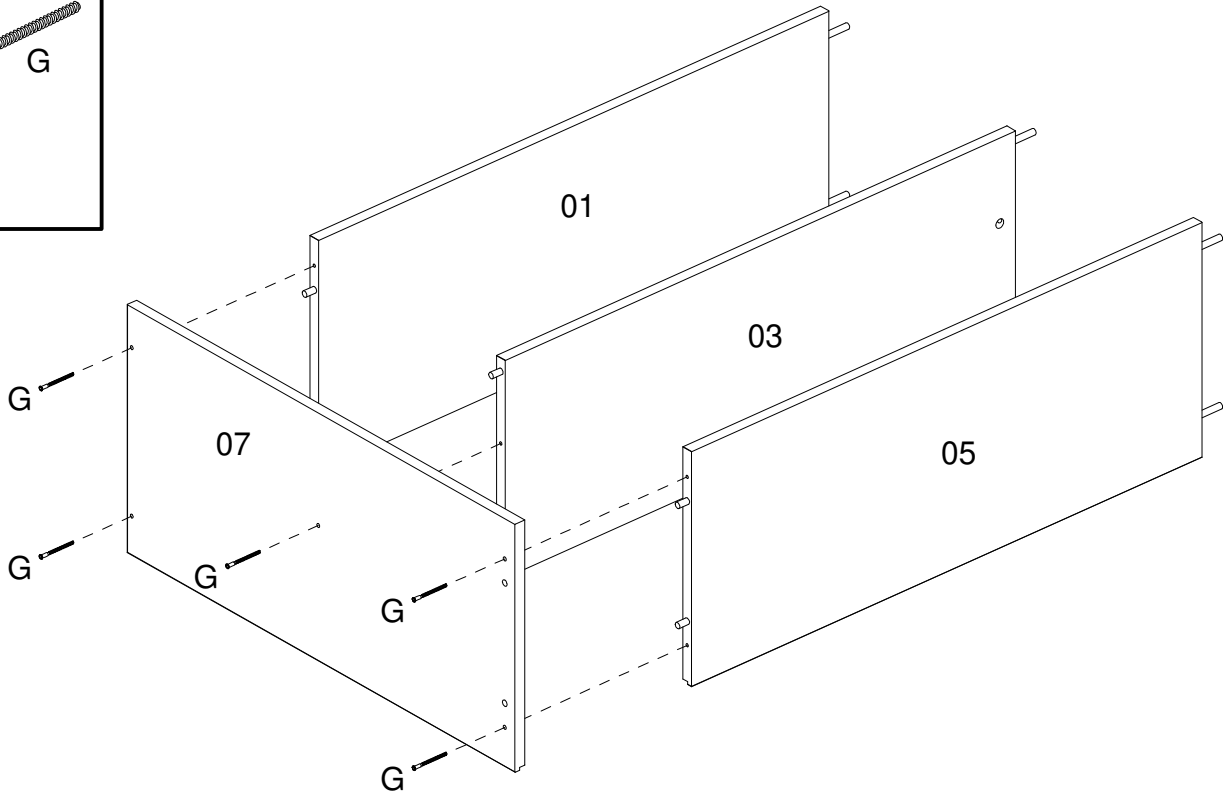
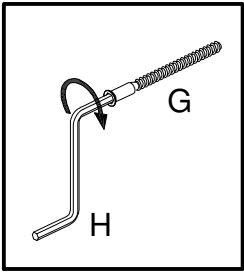

08

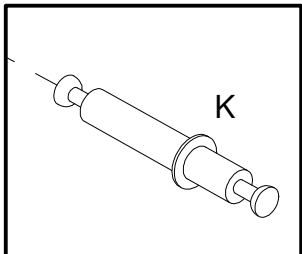
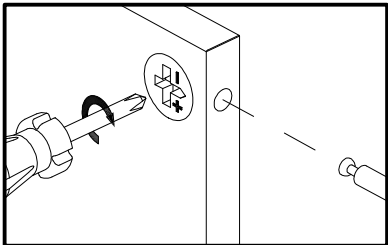
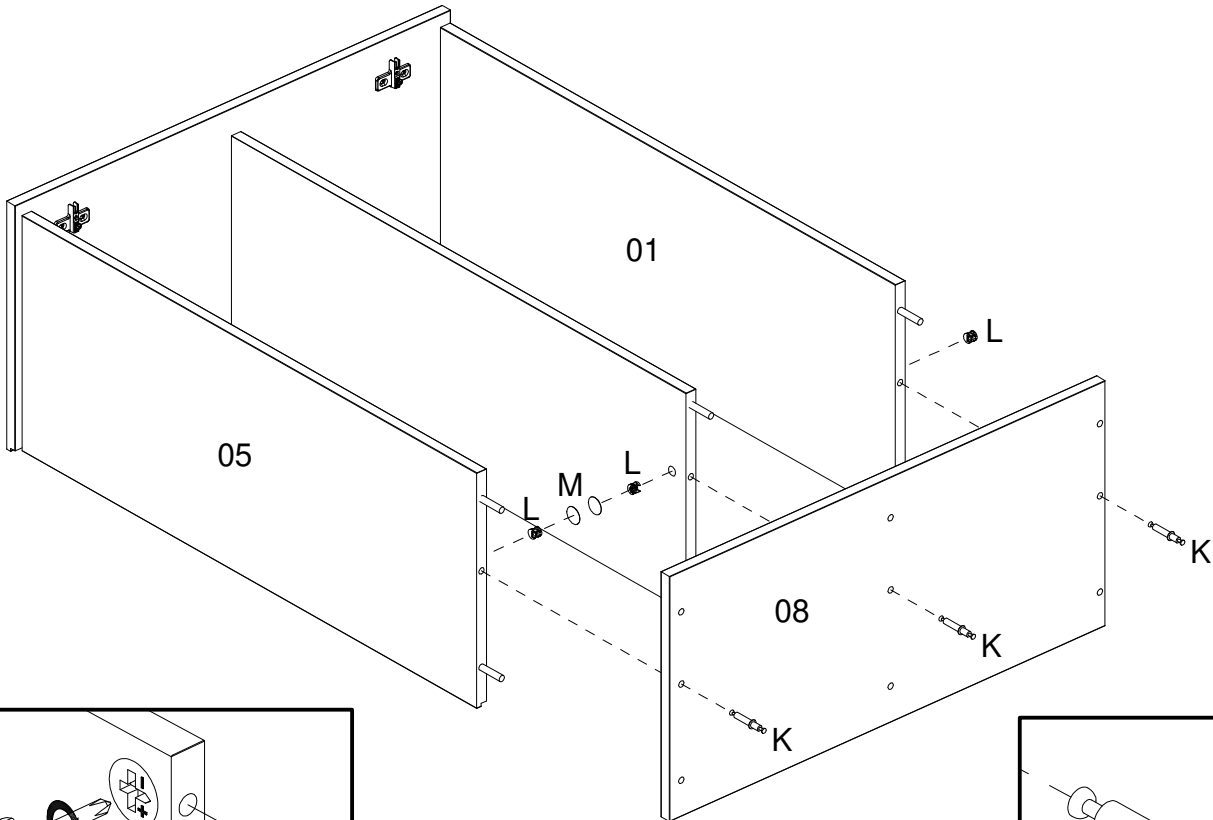

09

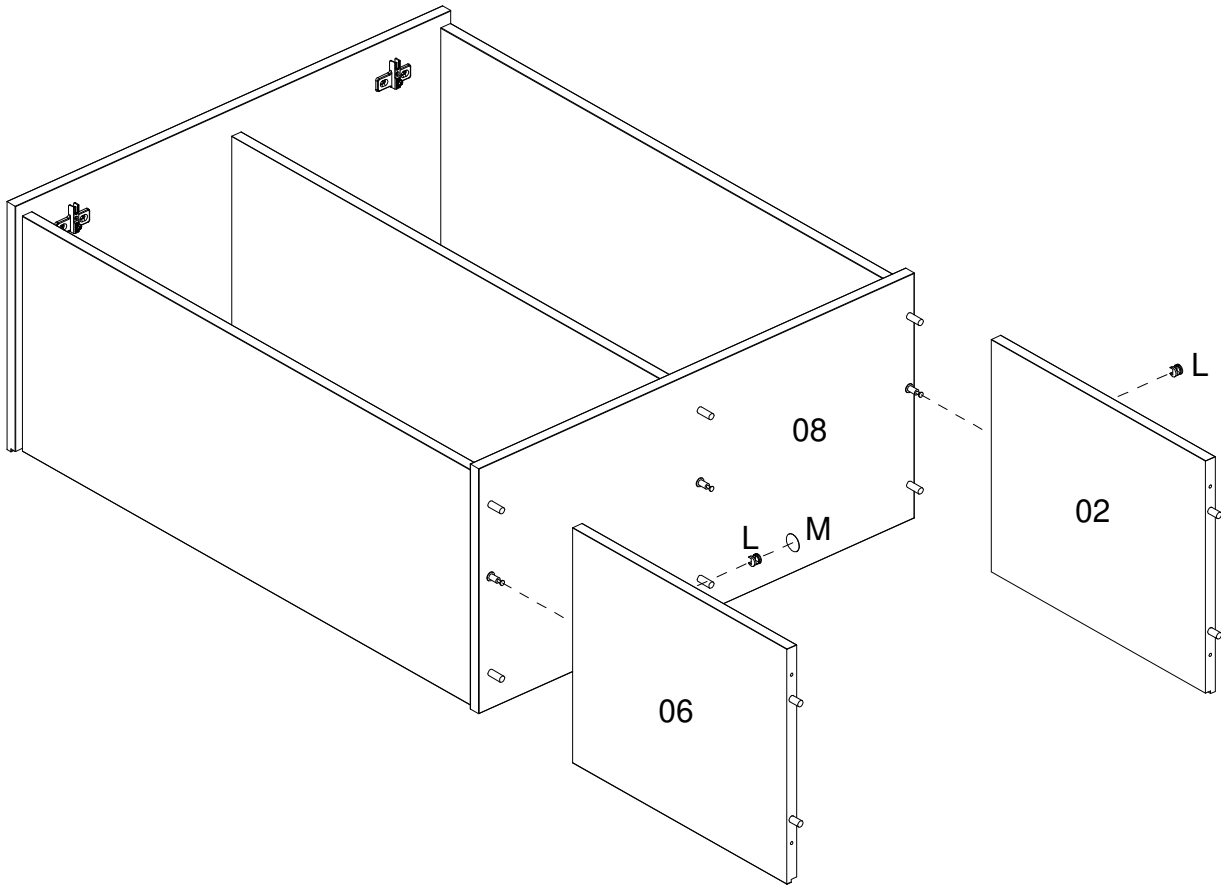

10

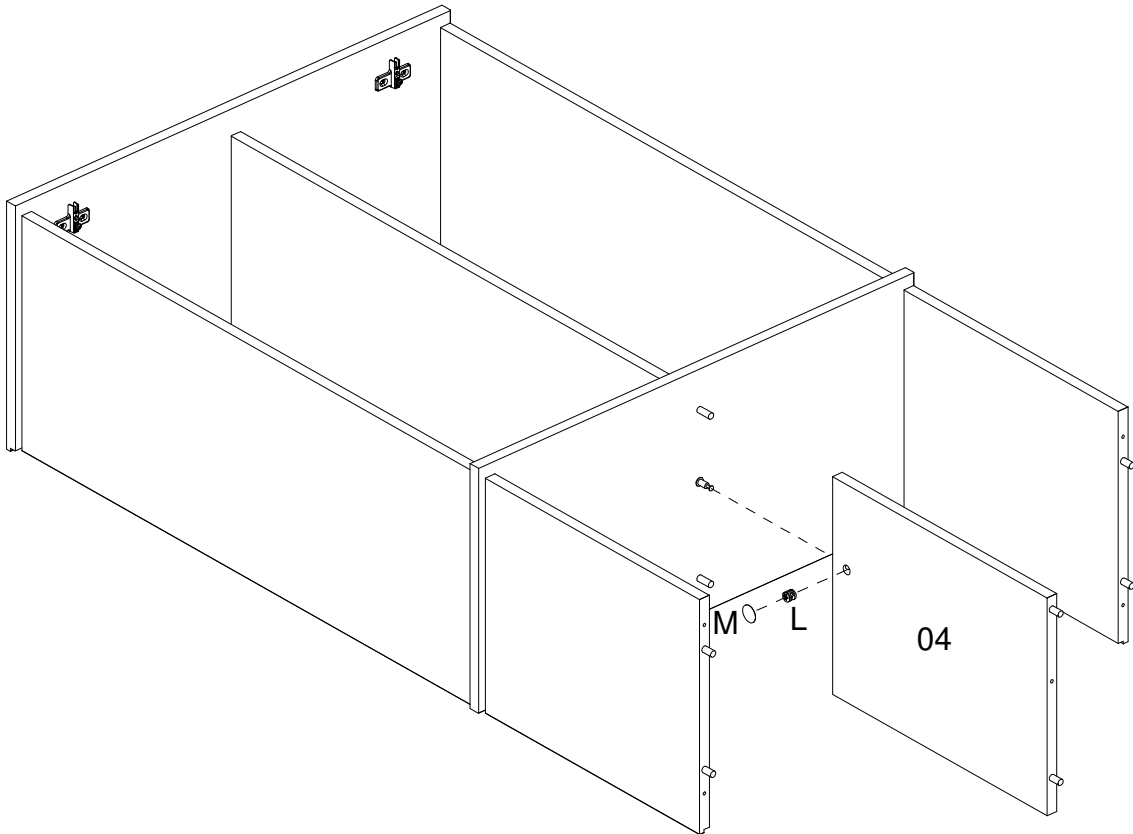

11

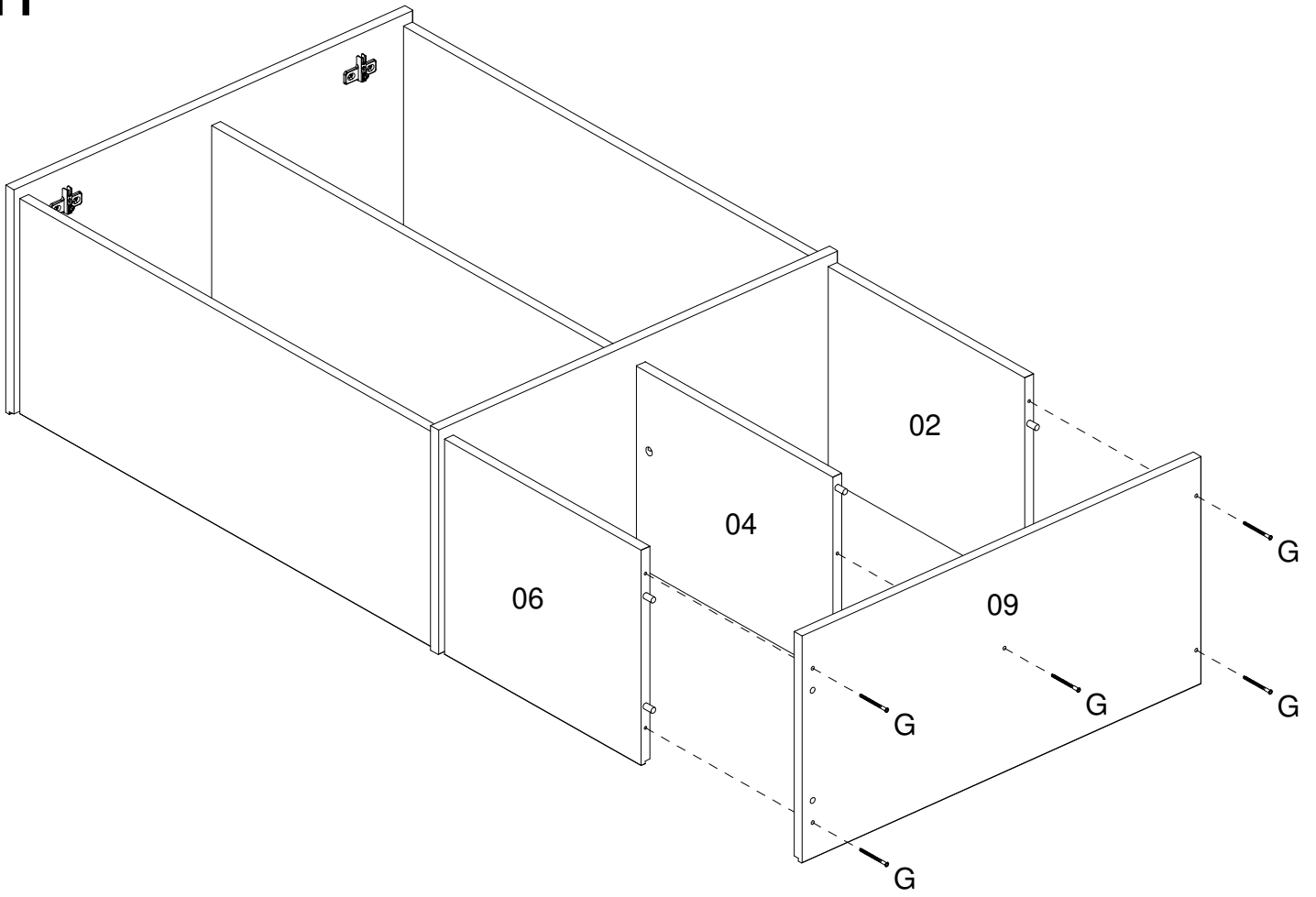

12

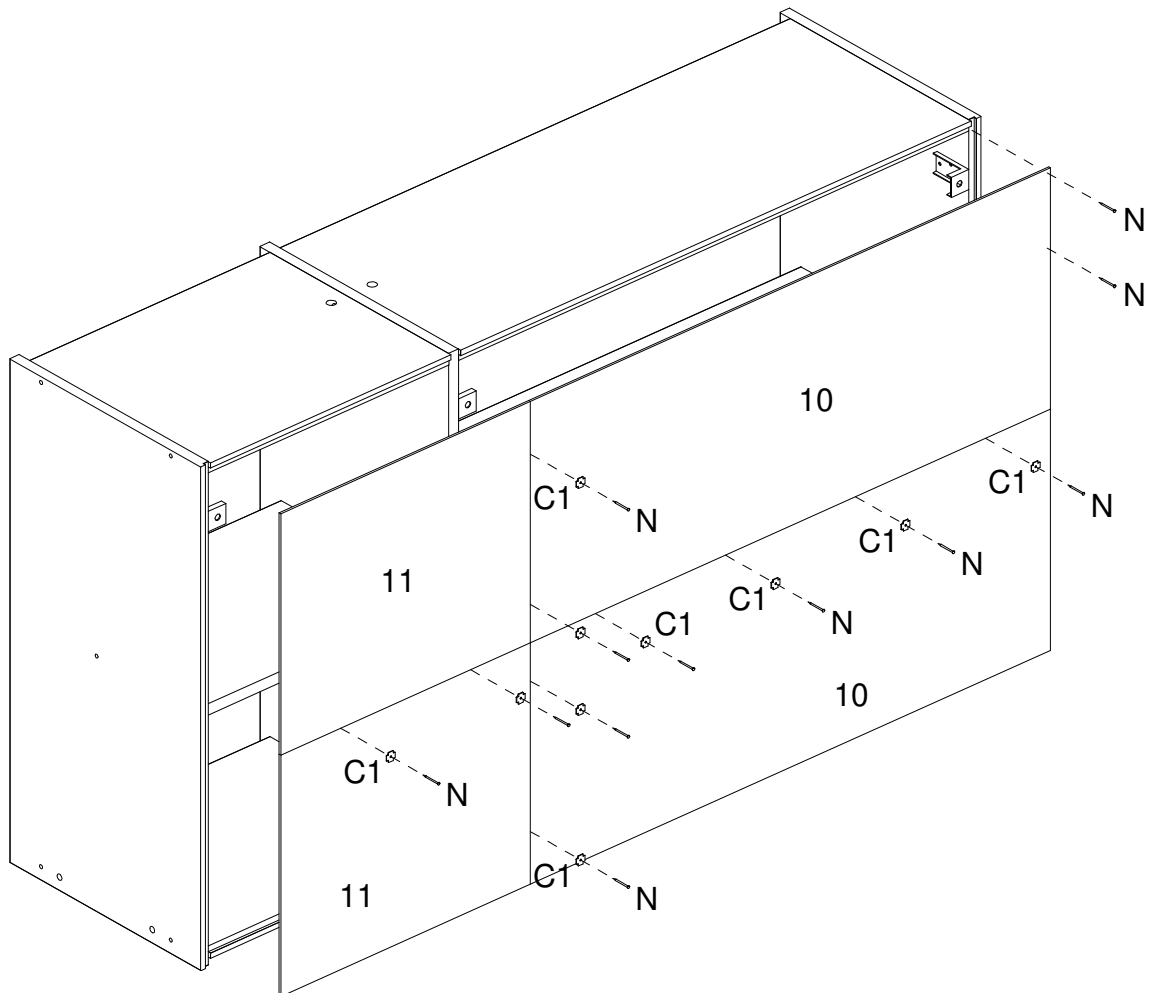

13

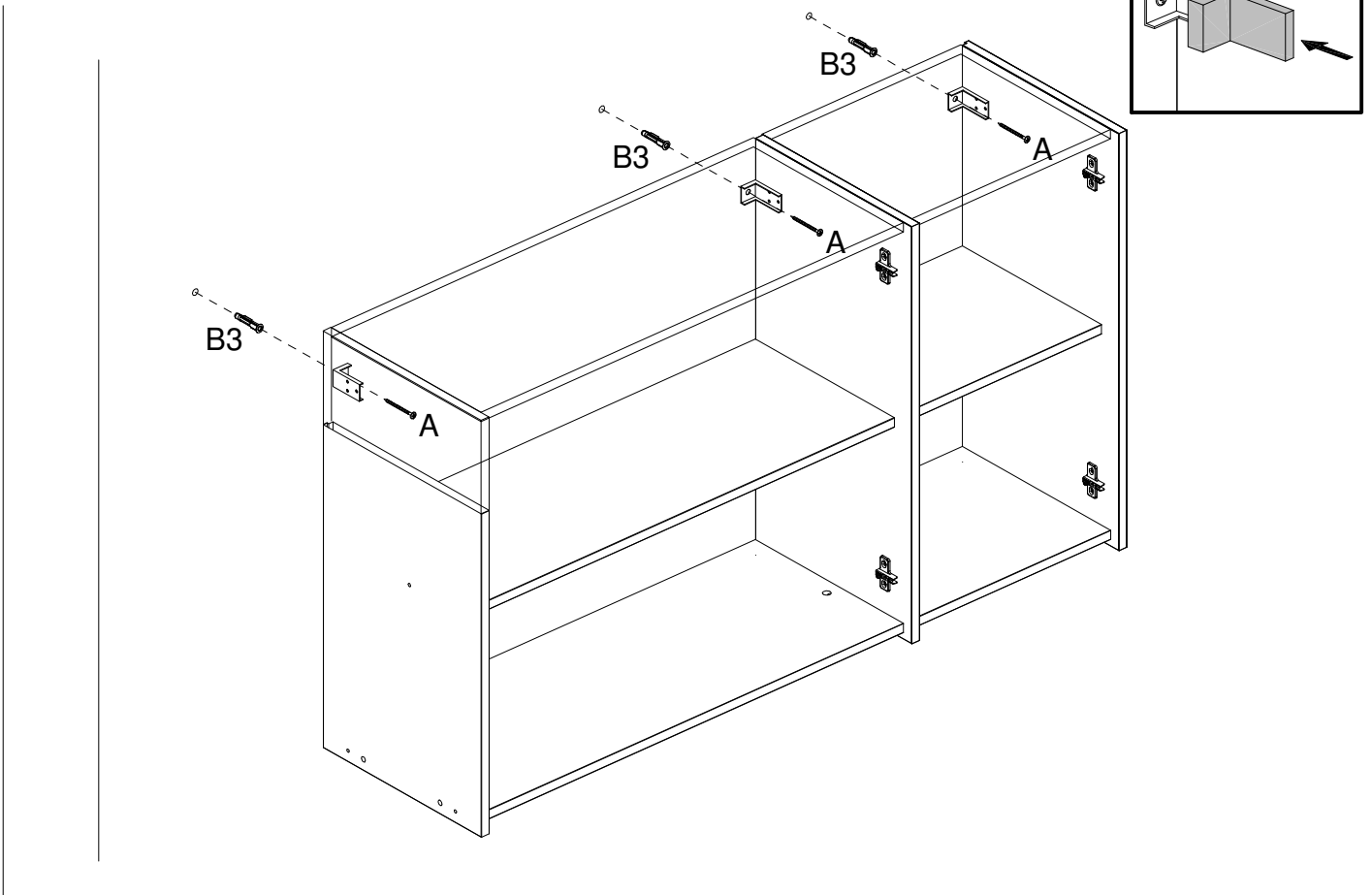

14

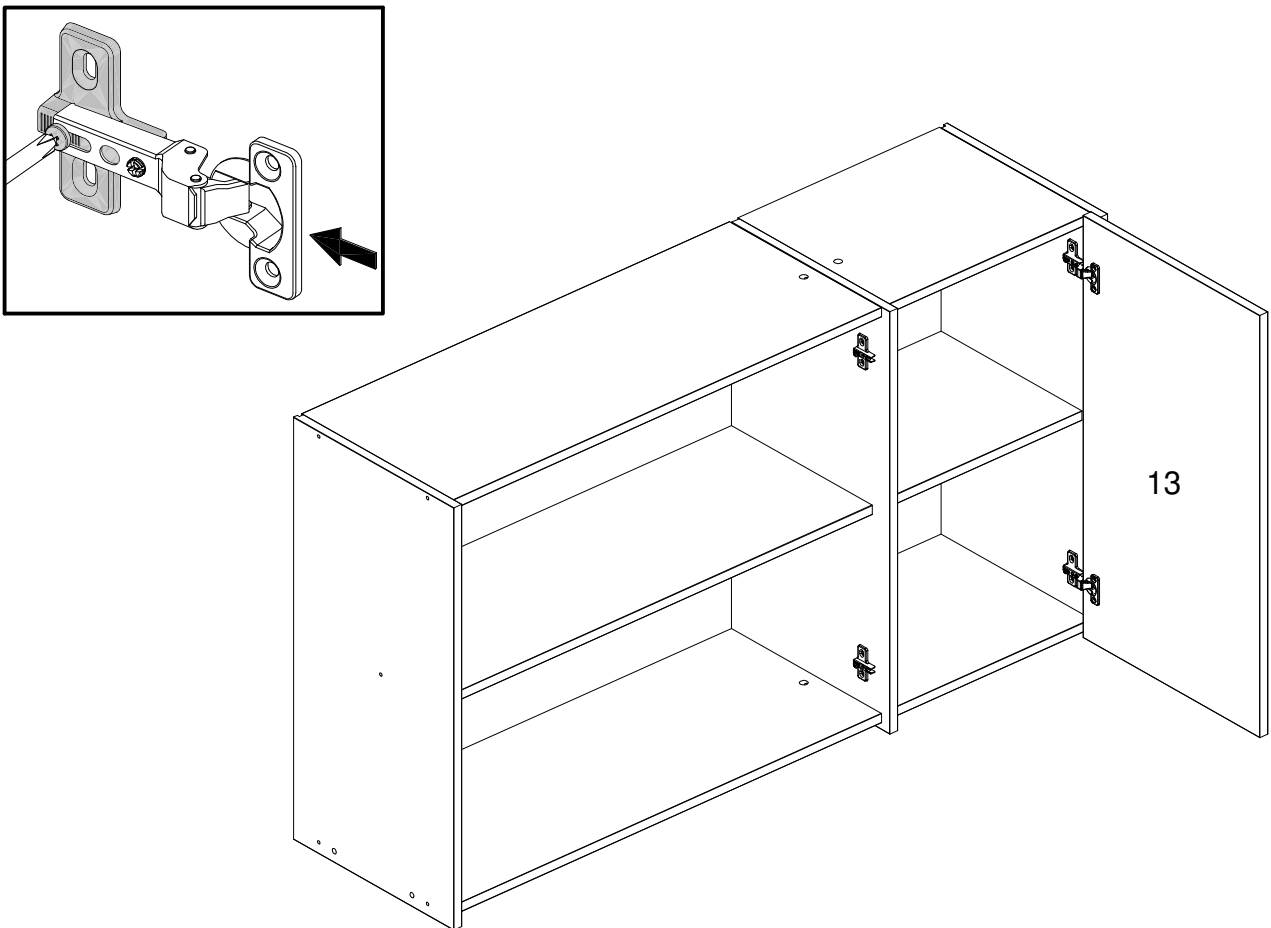

15

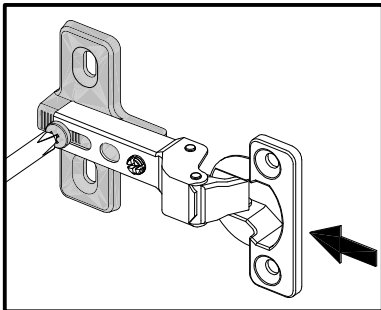
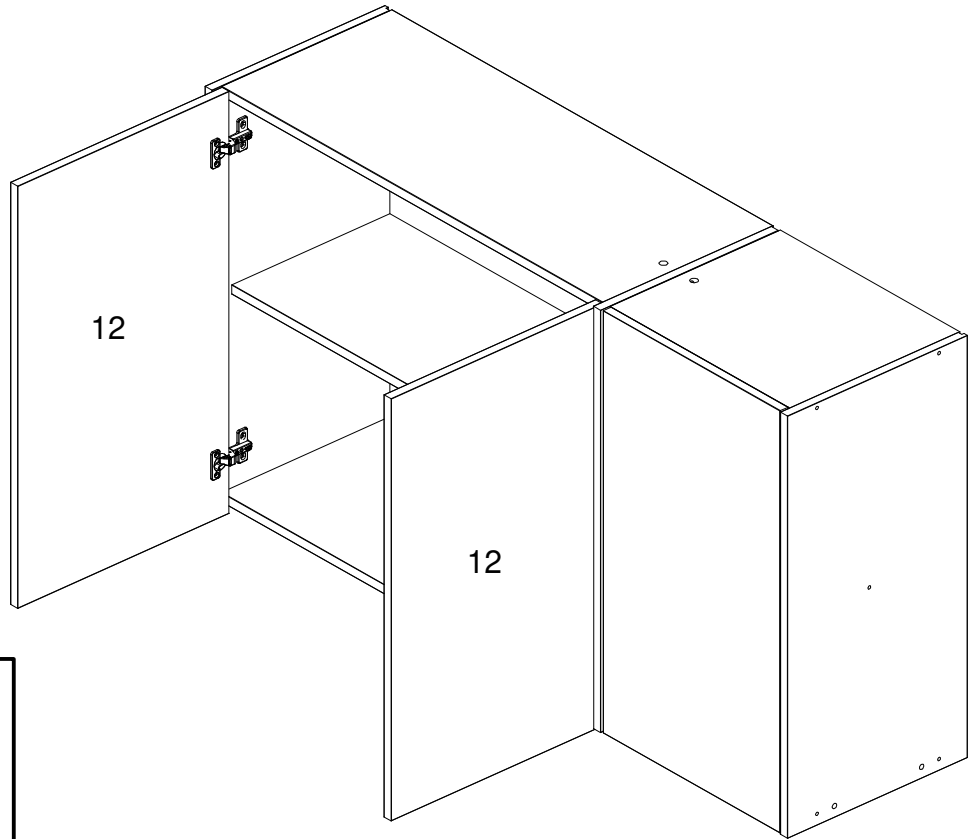

16

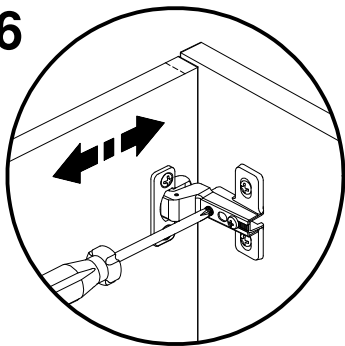

Horizontal Adjustment
Regulagem Horizontal
Ajuste Horizontal

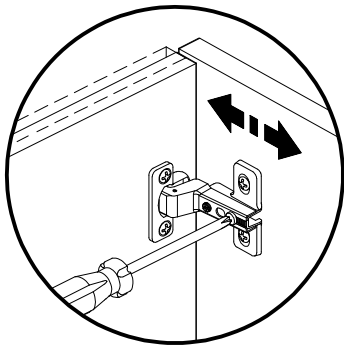

Depth Adjustment
Regulagem Profundidade
Ajuste Profundidad

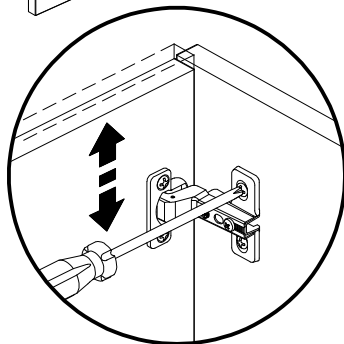

Vertical Adjustment
Regulagem Vertical
Ajuste Vertical

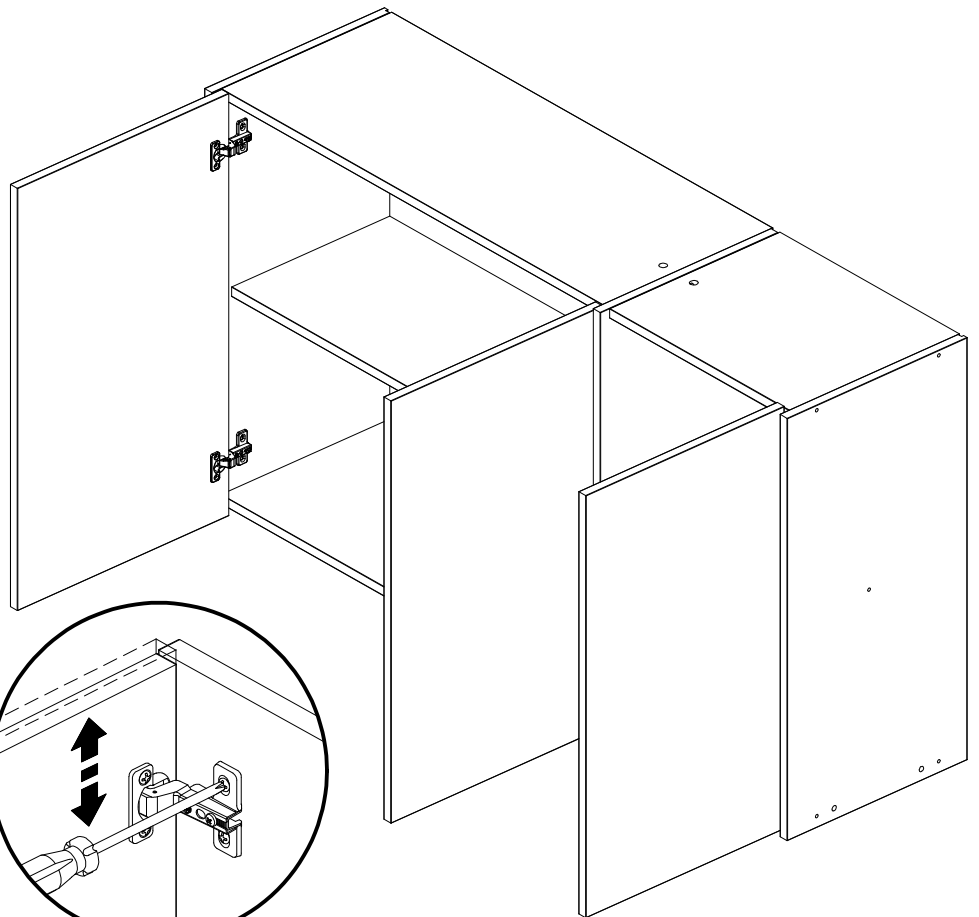

ASSEMBLY INSTRUCTIONS MANUAL DE MONTAGEM / INSTRUCCIONES DE ARMADO

CAMPANELE WALL CABINET 1 FLAP DOOR 30 3/16"
AEREO 1 PORTA BASCULANTE 766MM CAMPANELE
ARMARIO DE PARED 1 PUERTA HORIZONTAL 766 MM CAMPANELE

Reference 190381 | Revise
Referência 200043 | Revisão 05
Referencia

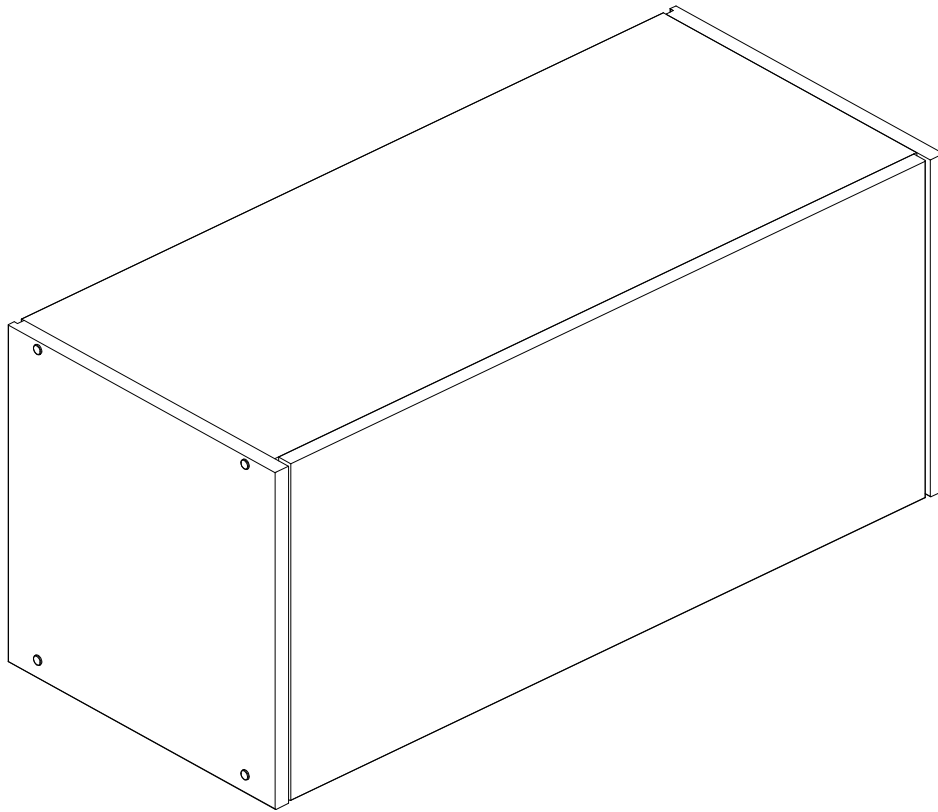

YOU WILL NEED / VOCÊ VAI PRECISAR DE / USTED NECESITARÁ

Tools not supplied / Ferramentas não fornecidas / Herramientas no incluidas

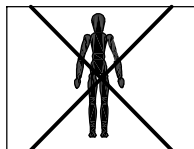

1 Person
1 Pessoa
1 Persona

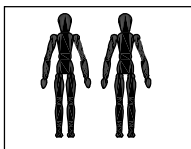

2 People
2 Pessoas
2 Personas

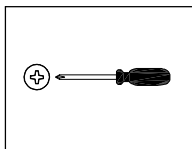

Screwdriver Phillips
Chave Phillips
Destornillador cruz

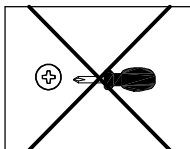

Small screwdriver Phillips
Chave Phillips Menor
Destornillador cruz menor

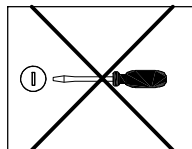

Screwdriver slotted
Chave fenda
Destornillador plano

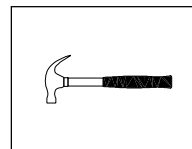

Hammer
Martelo
Martillo

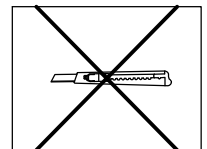

Stylet
Estilete
Estilete

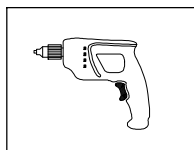

Drill machine
Furadeira
Taladro

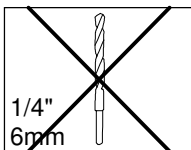

Drill bit
Broca
Taladro

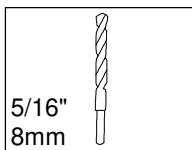

Drill bit
Broca
Taladro

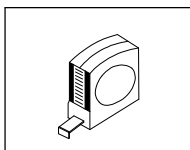

Measuring tape
Trena
Cinta de medición

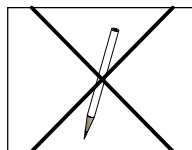

Pencil
Lápis
Lápis

NOTES: The separation of the accessories before you start the assembly will facilitate the same. In case of doubt on the size of the screws and bolts, use the ruler to bottom of page 3.

NOTAS: A separação dos acessórios antes de iniciar a montagem facilitará a mesma. Em caso de dúvida no tamanho dos parafusos e cavilhas, utilize a régua ao final da página 3.

NOTAS: La separación de los accesorios antes de comenzar el armado facilitará el mismo. En caso de duda sobre el tamaño de los tornillos y taquetes, utilice la regla al pie de página 3.

MAXIMUM RECOMMENDED WEIGHT
BEING THIS EVENLY DISTRIBUTED

PESO MÁXIMO RECOMENDADO SENDO
ESTE DISTRIBUÍDO UNIFORMEMENTE

PESO MÁXIMO RECOMENDADO SIENDO
ESTE UNIFORMEMENTE DISTRIBUIDO

| | LB | KG |
|----------|----|----|
| A | 22 | 10 |

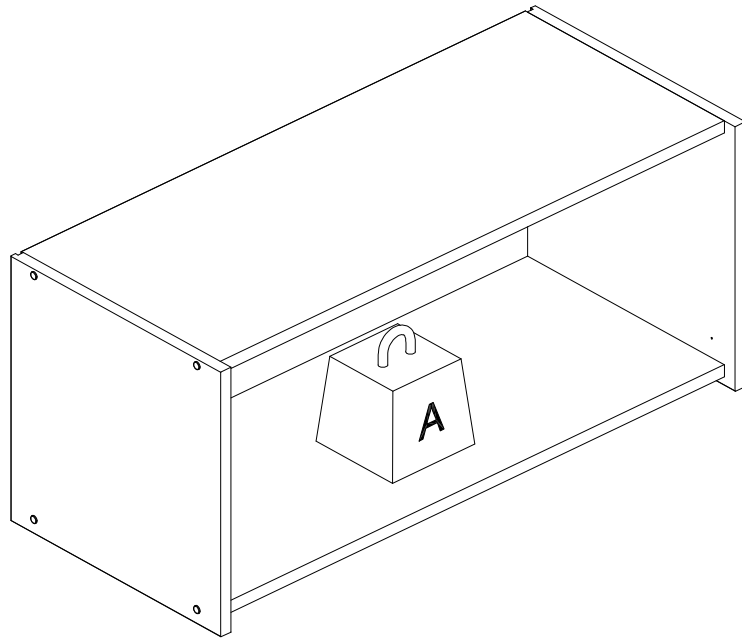





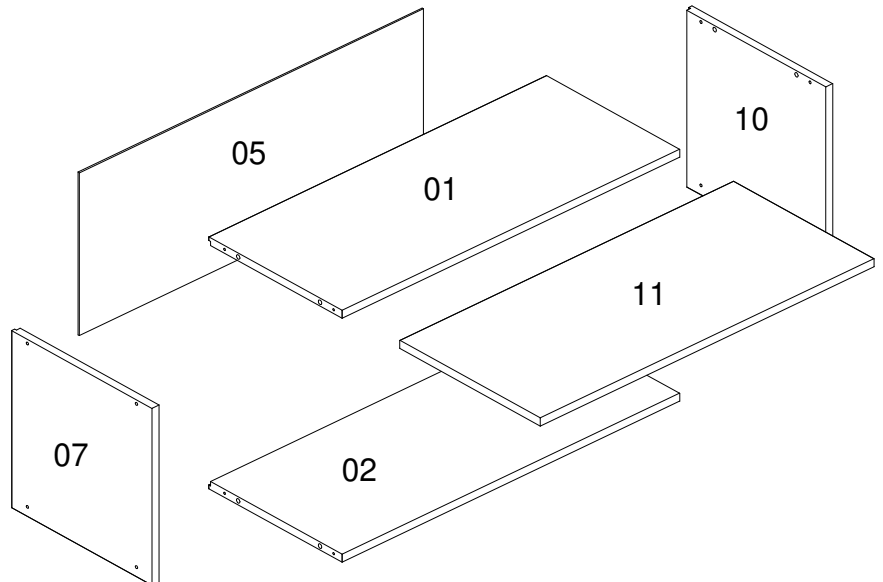



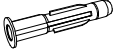
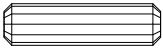
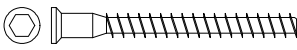

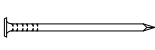
| Nº | Measures Inches | Medidas cm | Qty./Qtd. |
|----|-----------------------|-------------------|-----------|
| 01 | 12 3/8 x 29 x 5/8 | 31,3 x 73,6 x 1,5 | 1 |
| 02 | 12 3/8 x 29 x 5/8 | 31,3 x 73,6 x 1,5 | 1 |
| 05 | 29 1/2 x 11 7/8 x 1/8 | 75 x 30,3 x 0,3 | 1 |
| 07 | 13 x 13 x 5/8 | 33 x 33 x 1,5 | 1 |
| 10 | 13 x 13 x 5/8 | 33 x 33 x 1,5 | 1 |
| 11 | 28 3/4 x 13 x 5/8 | 73 x 33 x 1,5 | 1 |

PARTS IDENTIFICATION
IDENTIFICAÇÃO DAS PEÇAS / IDENTIFICACIÓN DE LAS PIEZAS



IDENTIFICATION OF ACCESSORIES IDENTIFICAÇÃO DOS ACESSÓRIOS/ IDENTIFICACIÓN DE ACCESORIOS

| | | | | |
|-----|---|--|-----------|----|
| A |  | Flanged head screw / Parafuso flangeado / Tornillo de cabeza flangeada | 5,0x60 mm | 2 |
| B3 |  | Bushing / Bucha expansiva / Tapón | 8x50 mm | 2 |
| E |  | Wooden dowel / Cavilha / Taquete | 8x30 mm | 8 |
| G |  | Structural screw / Parafuso estrutural / Tornillo estructural | 5,0x50 mm | 8 |
| H |  | Allen key / Chave allen / Liave allen | 3 mm | 1 |
| I |  | Structural screw cover/Tampa parafuso estrutural/Tapa tornillo estructural | - | 8 |
| N |  | Nail / Prego / Clavo | 10x10 | 20 |
| N5 |  | Support "L" / Suporte "L" / Soporte "L" | - | 2 |
| N6 |  | Cover / Capa / Cubierta | - | 2 |
| S |  | Pan head screw / Parafuso panela / Tornillo de pan | 3,5x14 mm | 16 |
| S7A |  | Gas piston / Pistão a gás / Pistón de gas | - | 1 |
| S7B |  | Side support piston / Suporte pistão lateral / Soporte pistón lateral | - | 1 |
| S7C |  | Door support piston / Suporte pistão porta / Soporte pistón puerta | - | 1 |
| S7D |  | Pan head screw / Parafuso panela / Tornillo de pan | 3,5x12 mm | 5 |
| Z13 |  | Metal hinge straight / Dobradiça reta / Bisagra recta | 35 mm | 2 |



PRE-ASSEMBLE
PRÉ-MONTAGEM / PRE ARMADO

01

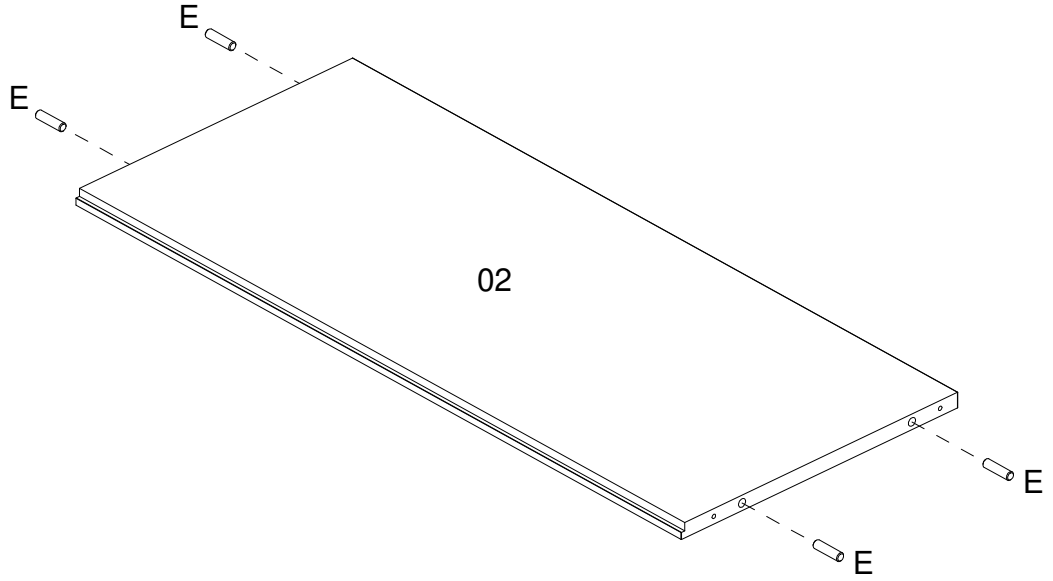
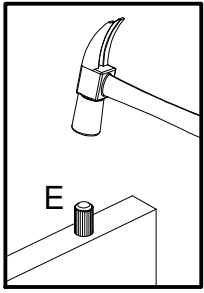

02

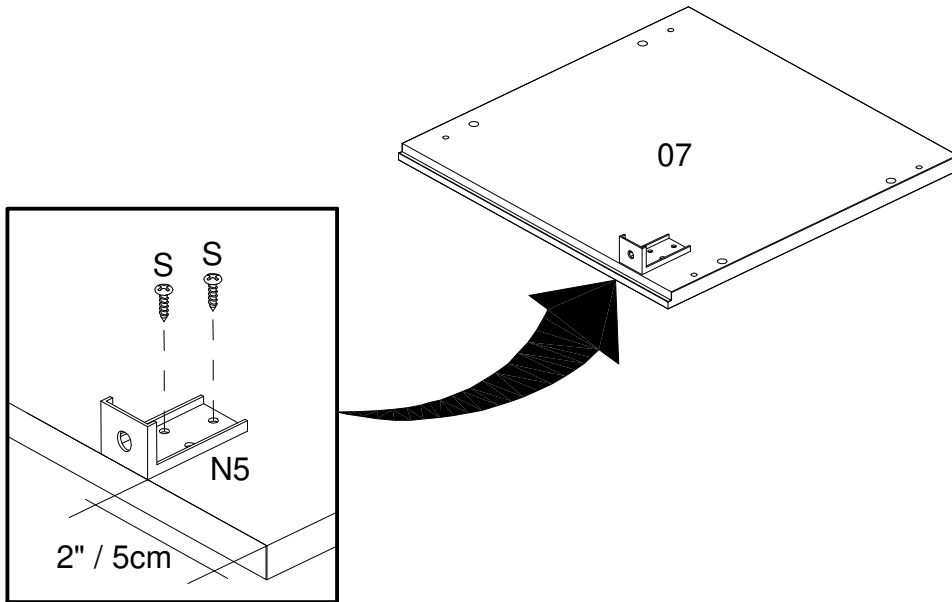

03

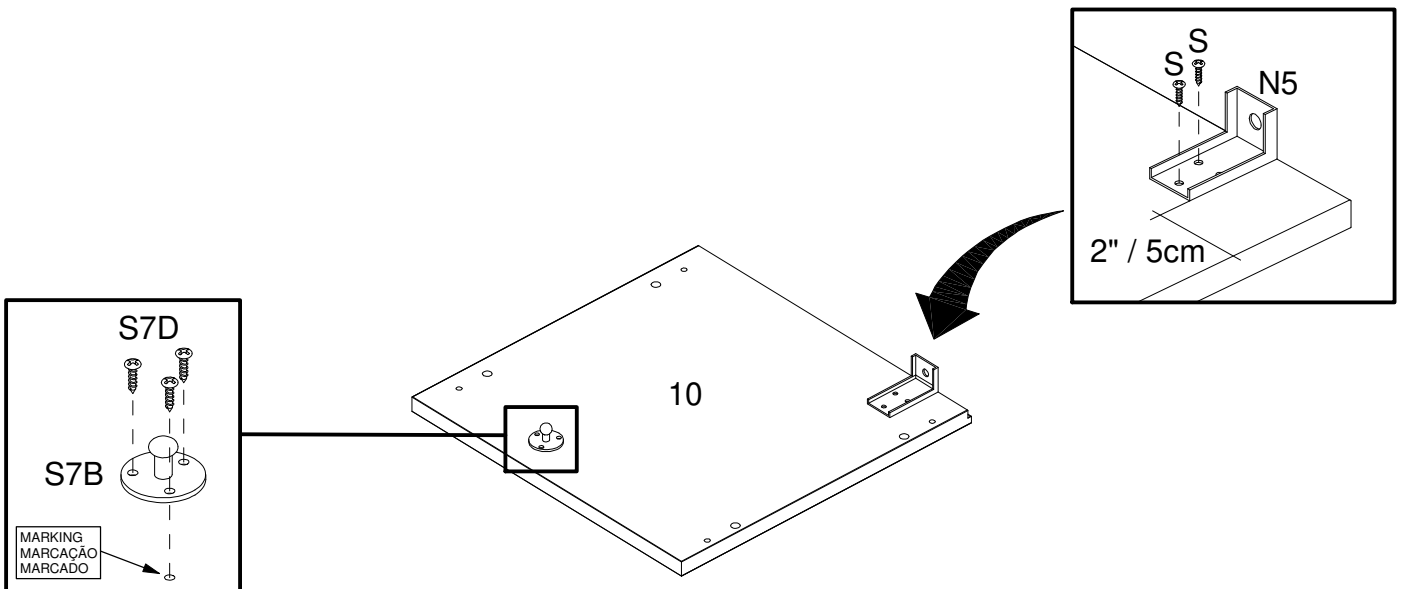

04

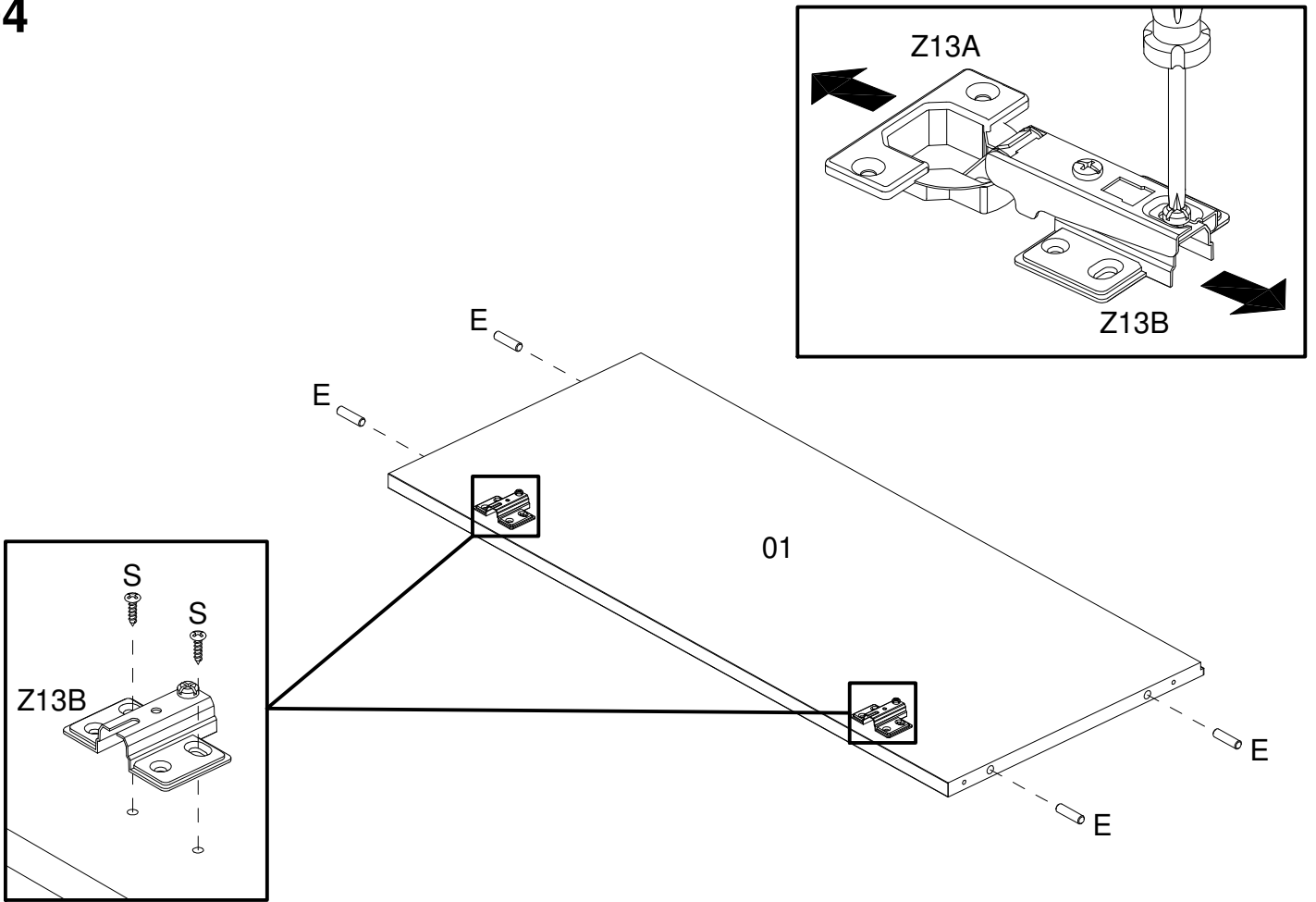

05

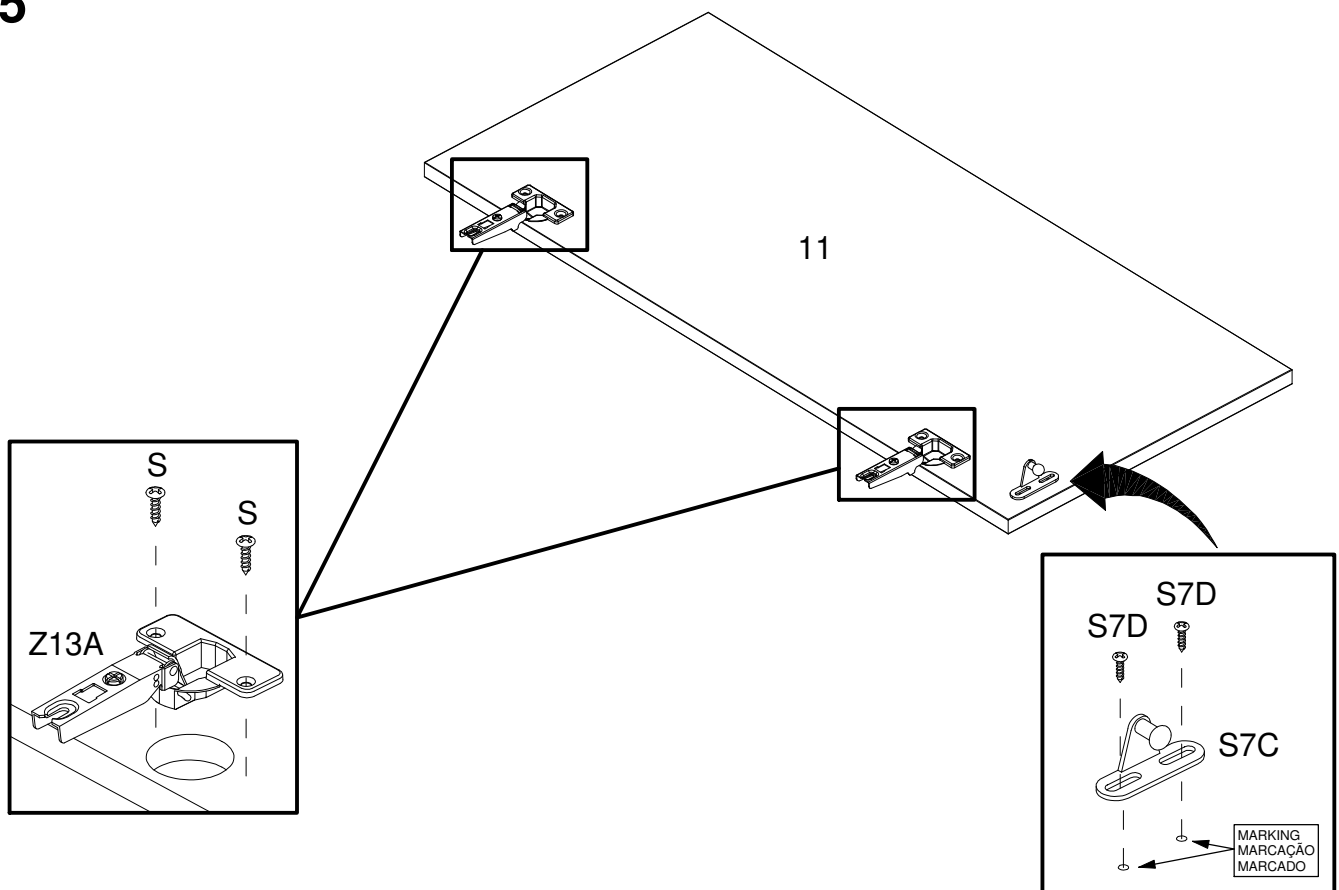

ASSEMBLY
MONTAGEM / ARMADO

06

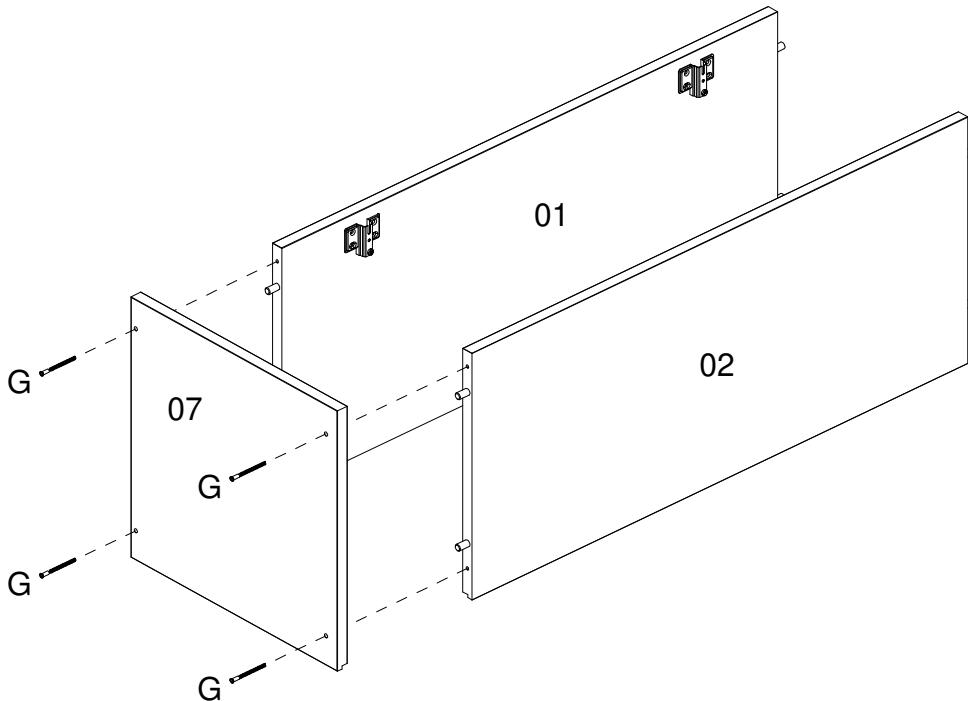
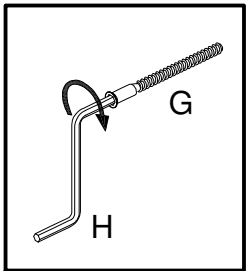

07

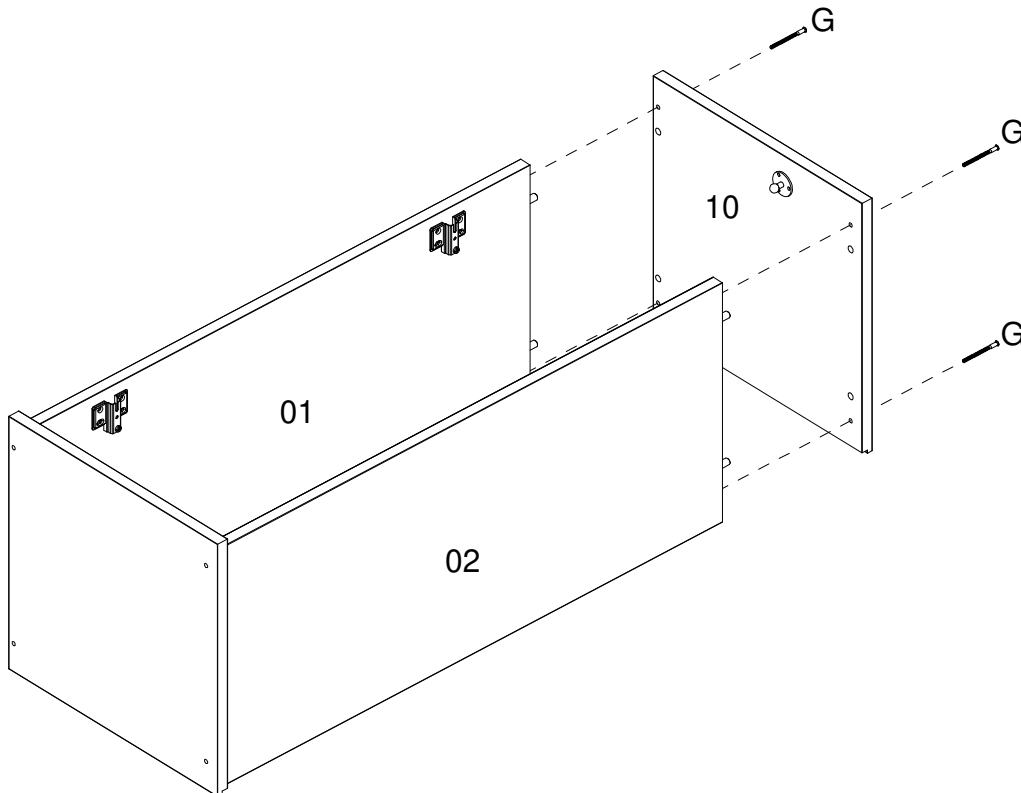

08

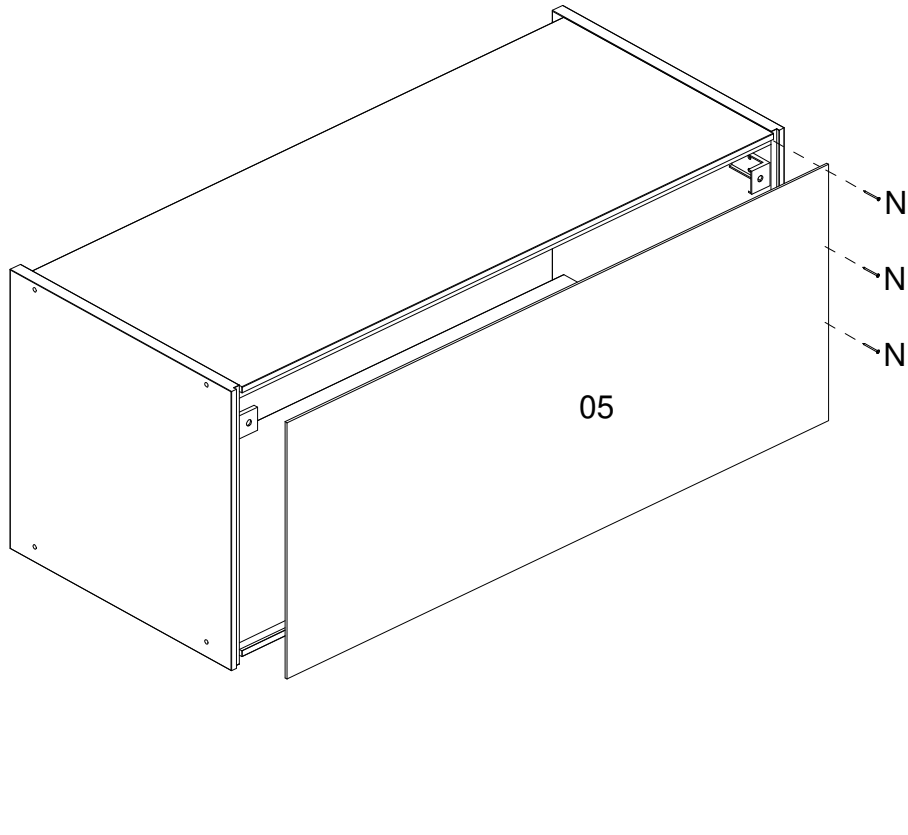

09

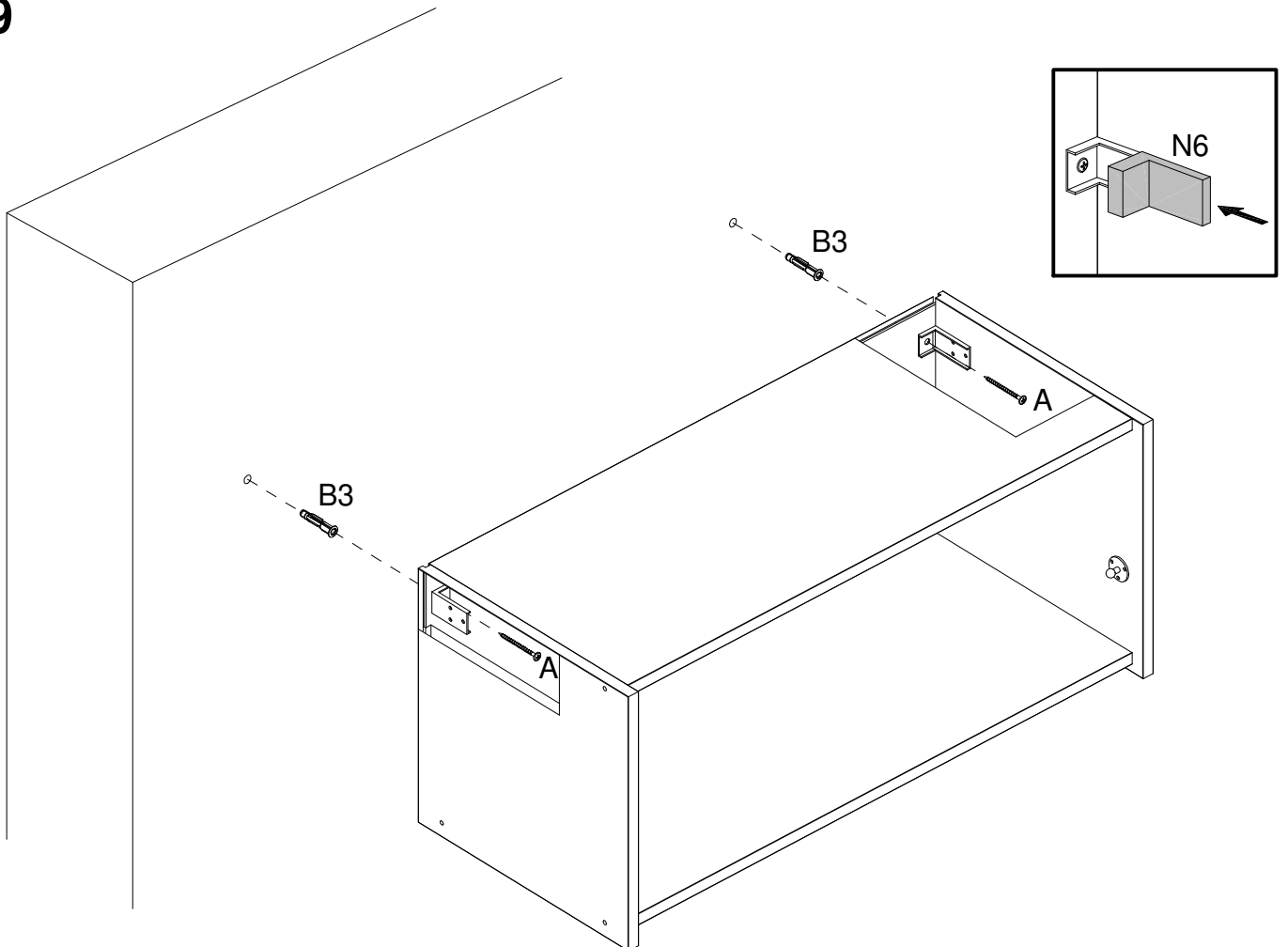

10

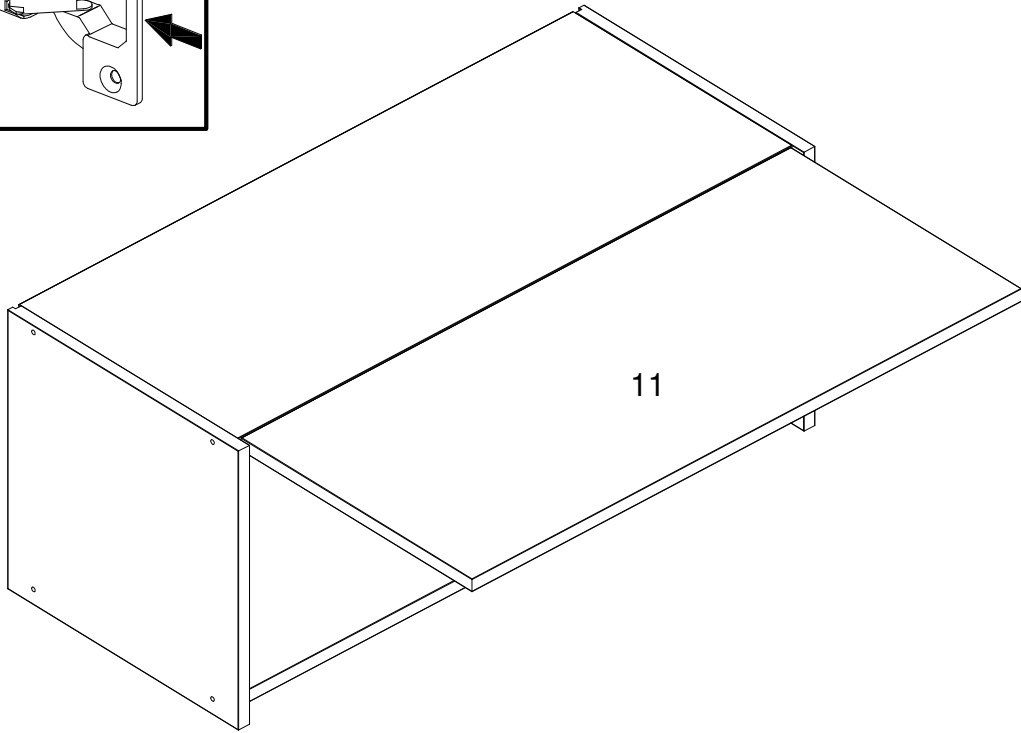
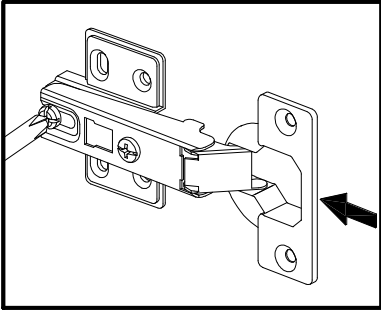

11

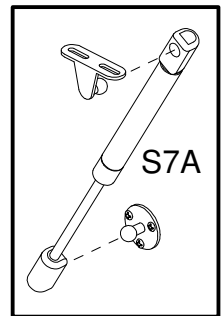
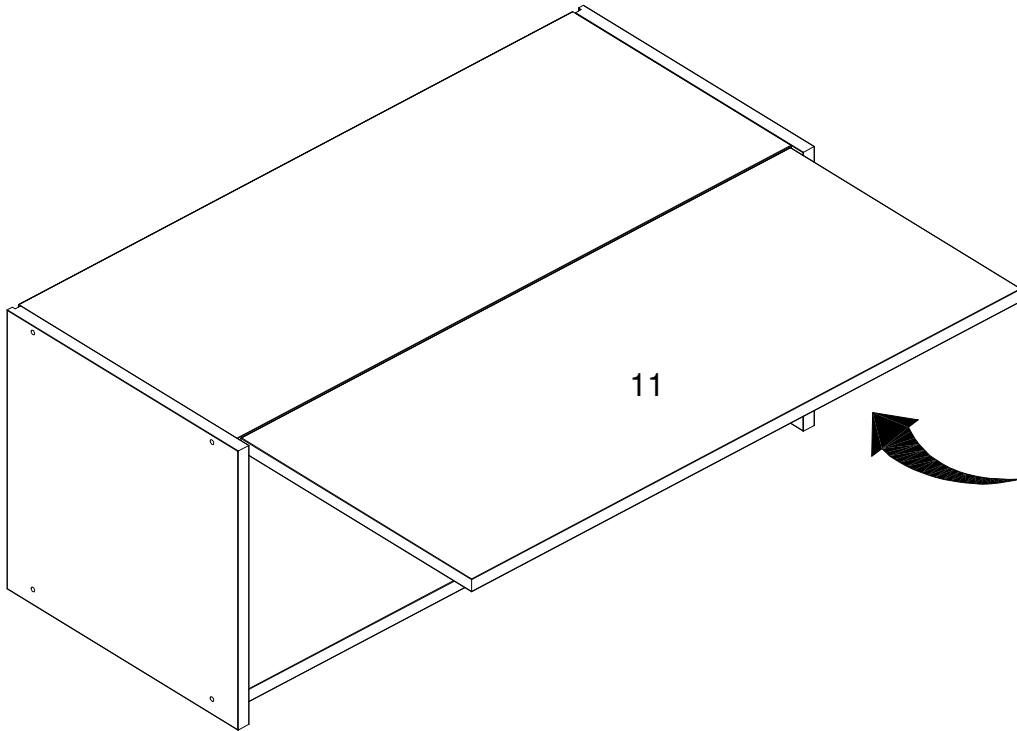

12

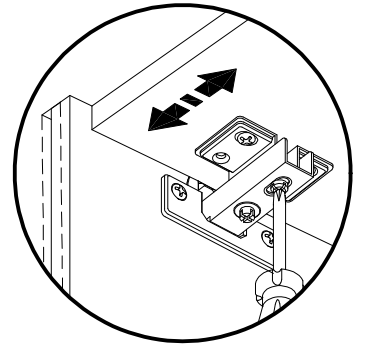
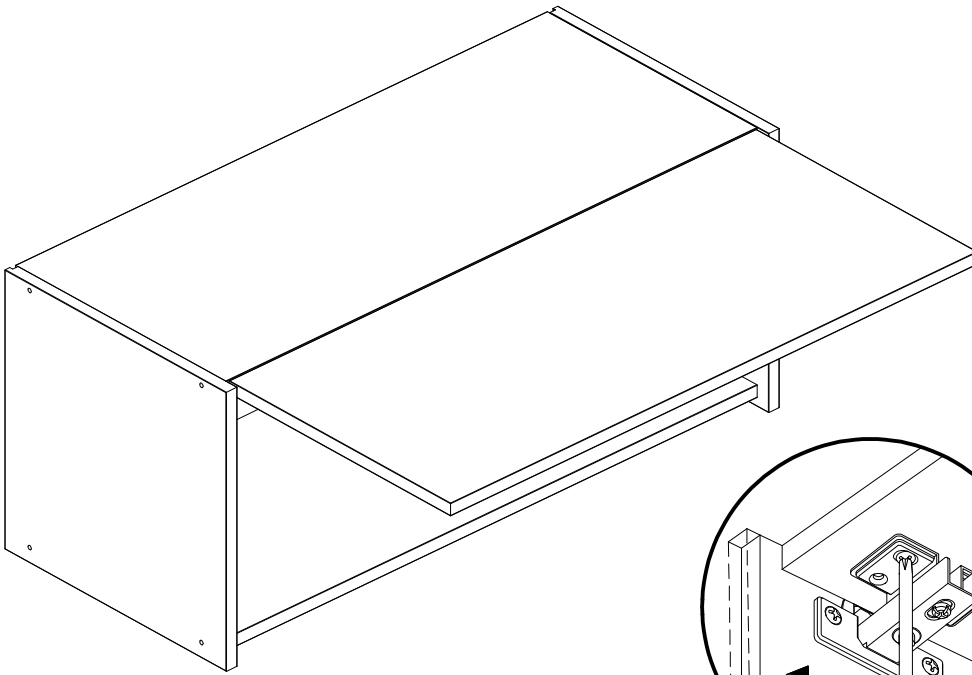

Depth Adjustment
Regulagem Profundidade
Ajuste Profundidad

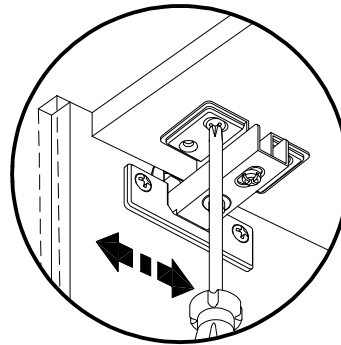

Horizontal Adjustment
Regulagem Horizontal
Ajuste Horizontal

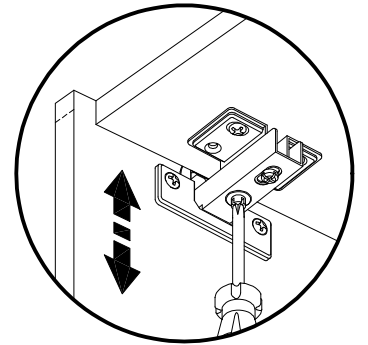

Vertical Adjustment
Regulagem Vertical
Ajuste Vertical

13

