

ASSEMBLY INSTRUCTIONS MANUAL DE MONTAGEM / INSTRUCCIONES DE ARMADO

CANELONE WALL CABINET 1 FLAP DOOR 31 1/2"

AEREO 1 PORTA BASCULANTE 800MM CANELONE

ARMARIO DE PARED 1 PUERTA HORIZONTAL 800MM CANELONE

Reference
Referência
Referencia

220370

Revised
Revisão
Revisión

00



ENGLISH
PORTUGUÊS
ESPAÑOL

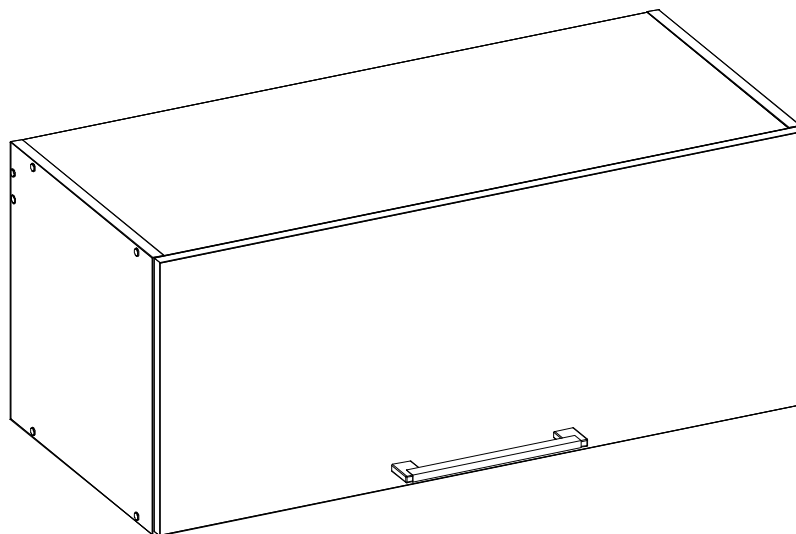

MAXIMUM RECOMMENDED WEIGHT
BEING THIS EVENLY DISTRIBUTED.

PESO MÁXIMO RECOMENDADO SENDO
ESTE DISTRIBUÍDO UNIFORMEMENTE.

PESO MÁXIMO RECOMENDADO SIENDO
ESTE UNIFORMEMENTE DISTRIBUIDO.

| | LB | KG |
|---|----|----|
| F | 22 | 10 |

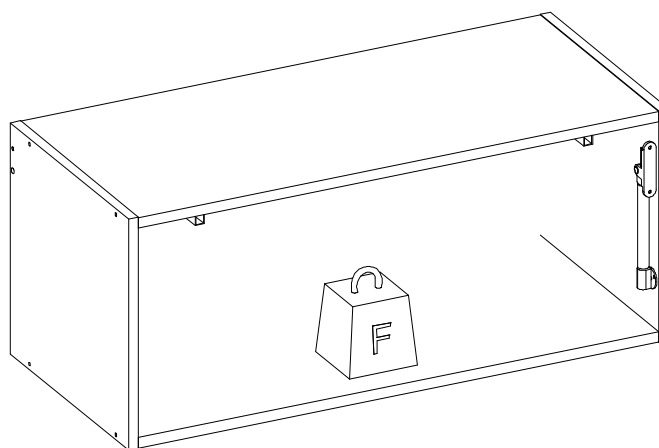

| Nº | Measures_Inches | Medidas_cm | Qty./Qtd. |
|----|-----------------------|-------------------|-----------|
| 01 | 30 3/8 x 13 3/4 x 5/8 | 77.0 x 35.0 x 1.5 | 1 |
| 02 | 30 3/8 x 13 3/4 x 5/8 | 77.0 x 35.0 x 1.5 | 1 |
| 03 | 13 1/4 x 13 3/4 x 5/8 | 33.5 x 35.0 x 1.5 | 1 |
| 04 | 13 1/4 x 13 3/4 x 5/8 | 33.5 x 35.0 x 1.5 | 1 |
| 05 | 30 3/8 x 2 3/4 x 5/8 | 77.0 x 7.0 x 1.5 | 1 |
| 07 | 30 7/8 x 12 1/2 x 1/8 | 78.4 x 31.8 x 0.3 | 1 |
| 08 | 13 x 31 3/8 x 5/8 | 33.0 x 79.6 x 1.5 | 1 |

PARTS IDENTIFICATION IDENTIFICAÇÃO DAS PEÇAS / IDENTIFICACIÓN DE LAS PIEZAS

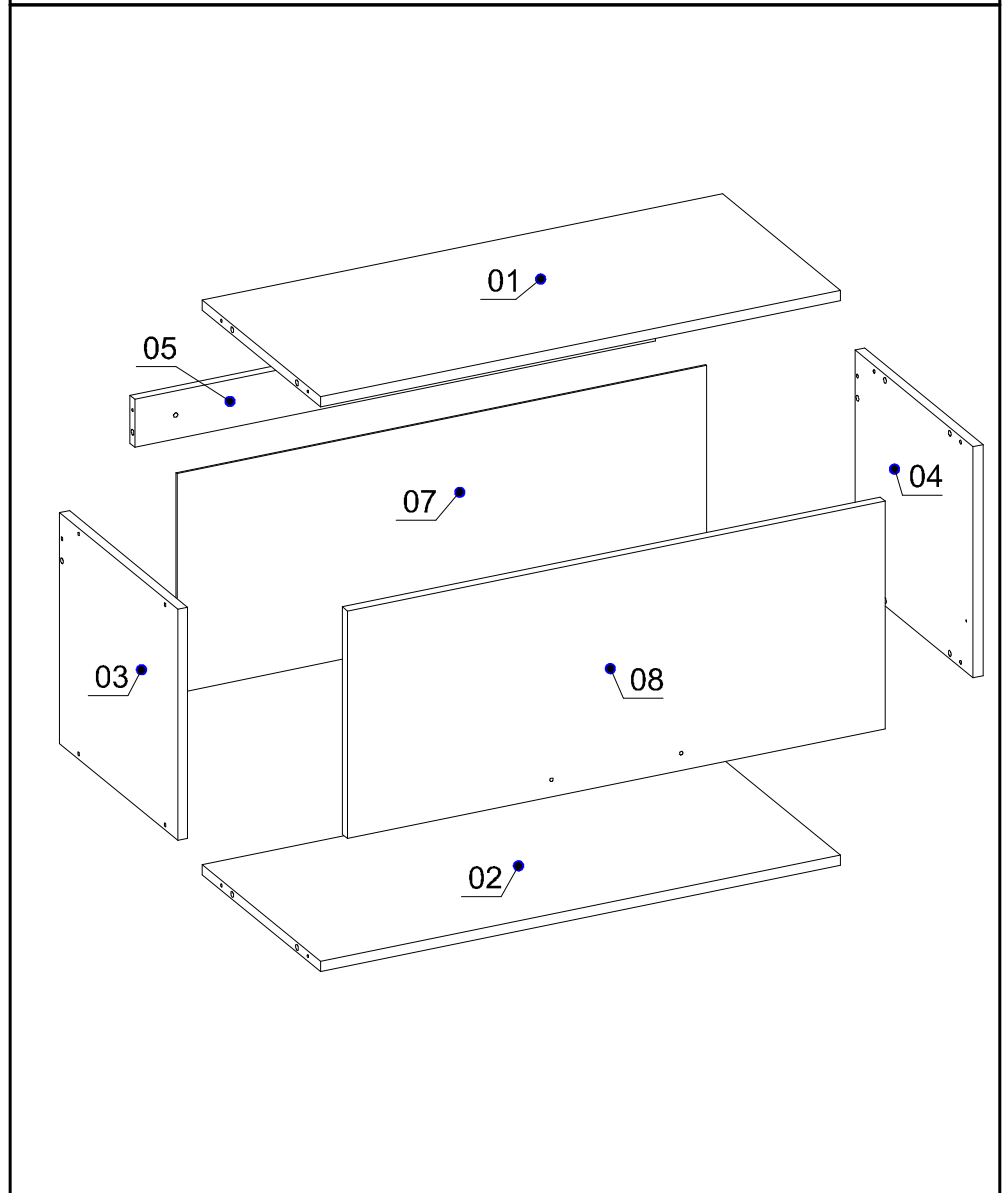

YOU WILL NEED / VOCÊ VAI PRECISAR DE / USTED NECESITARÁ

Tools not supplied / Ferramentas não fornecidas / Herramientas no incluidas

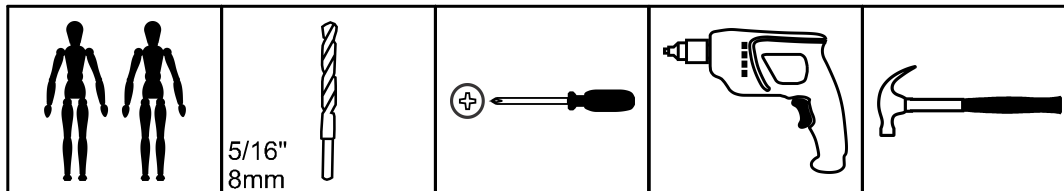

2 People
2 Pessoas
2 Personas

5/16"
8mm
Drill bit
Broca
Taladro

Screwdriver Phillips
Chave Phillips
Destornillador cruz

Drill machine
Furadeira
Taladro

Hammer
Martelo
Martillo











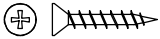
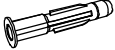
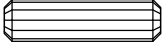
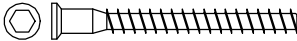

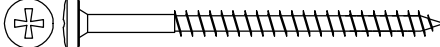

The separation of the accessories before you start the assembly will facilitate the same. In case of doubt on the size of the screws and bolts, use the ruler to bottom of page 3.

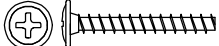
A separação dos acessórios antes de iniciar a montagem facilitará a mesma. Em caso de dúvida no tamanho dos parafusos e cavilhas, utilize a régua ao final da página 3.

La separación de los accesorios antes de comenzar el armado facilitará el mismo. En caso de duda sobre el tamaño de los tornillos y taquetes, utilice la regla al pie de página 3.

IDENTIFICATION OF ACCESSORIES IDENTIFICAÇÃO DOS ACESSÓRIOS/ IDENTIFICACIÓN DE ACCESORIOS

| | | | | |
|------|---|--|-----------|----|
| A8 |  | Flat head screw / Parafuso chato / Tornillo de cabeza plana | 3,5x20 mm | 4 |
| B3 |  | Bushing / Bucha expansiva / Tapón | 8x50 mm | 3 |
| E |  | Wooden dowel / Cavilha / Taquete | 8x30 mm | 10 |
| G |  | Structural screw / Parafuso estrutural / Tornillo estructural | 5,0x50 mm | 10 |
| H |  | Allen key / Chave allen / Liave allen | 3 mm | 1 |
| I |  | Structural screw cover/Tampa parafuso estrutural/Tapa tornillo estructural | - | 10 |
| i4 |  | Pan head screw / Parafuso panela / Tornillo de pan | 5,0x70 mm | 3 |
| K11 |  | Silicone stop / Batente de silicone / Tope de silicona | 8 mm | 1 |
| o1 |  | Triangular support / Suporte triangular / Soporte triangular | - | 4 |
| S |  | Pan head screw / Parafuso panela / Tornillo de pan | 3,5x14 mm | 12 |
| T |  | Flanged head screw / Parafuso flangeado / Tornillo de cabeza flangeada | 3,5x25 mm | 2 |
| X16A |  | Gas piston / Pistão a gás / Pistón de gas | - | 1 |
| X16B |  | Side support piston / Suporte pistão lateral / Soporte pistón lateral | - | 1 |
| X16C |  | Pan head screw / Parafuso panela / Tornillo de pan | 3,5x14 mm | 5 |
| X19 |  | Handle / Puxador Citrino / Tirador | 192 mm | 1 |
| Z |  | Plastic hole plugs / Tapa furo plástico / Tapones plásticos | 8 mm | 2 |
| Z13 |  | Metal hinge straight / Dobradiça reta / Bisagra recta | 35 mm | 2 |



PRE-ASSEMBLE
PRÉ-MONTAGEM / PRE ARMADO

01

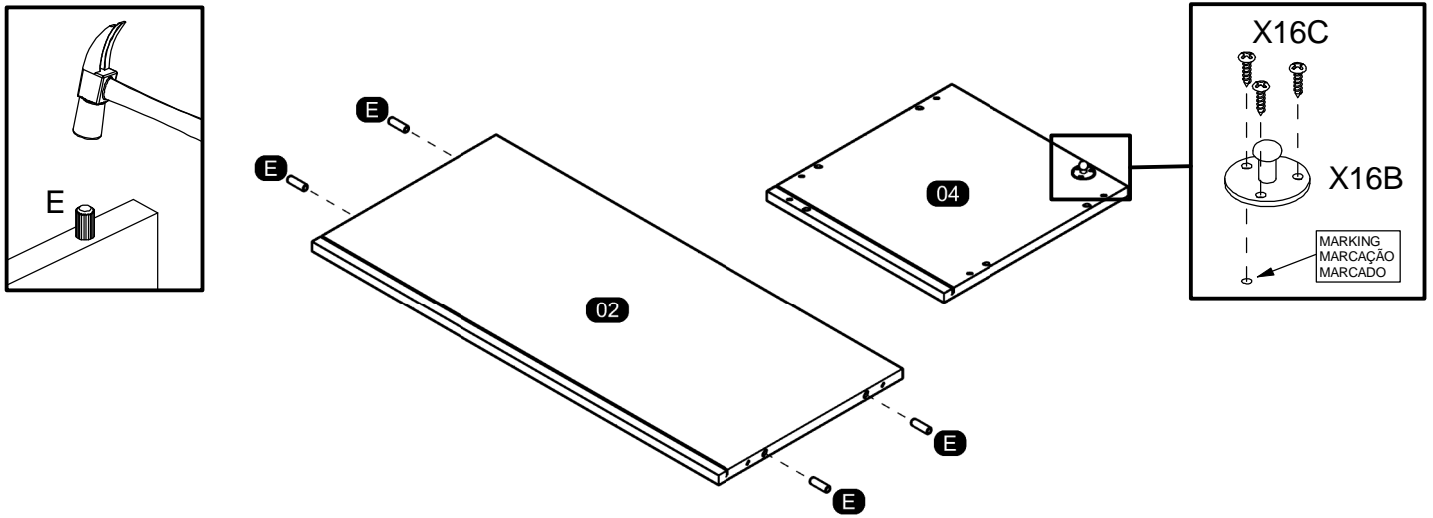

02

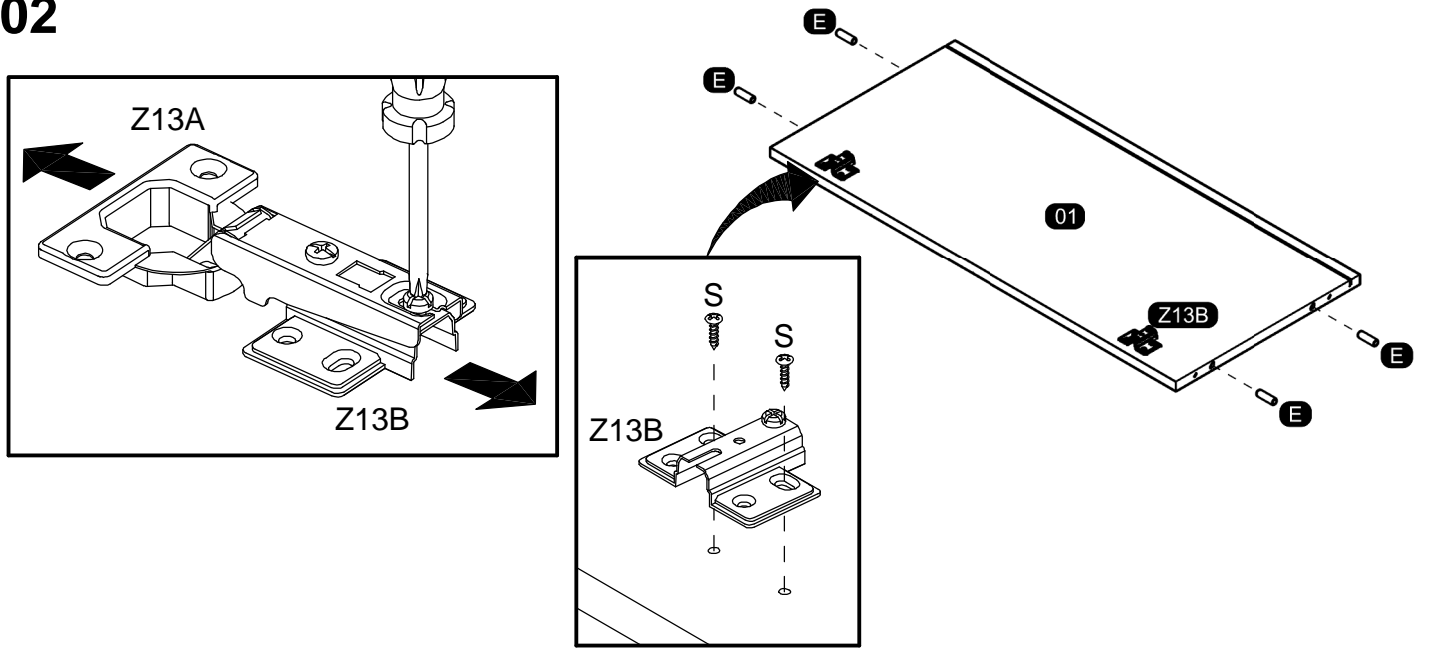

03

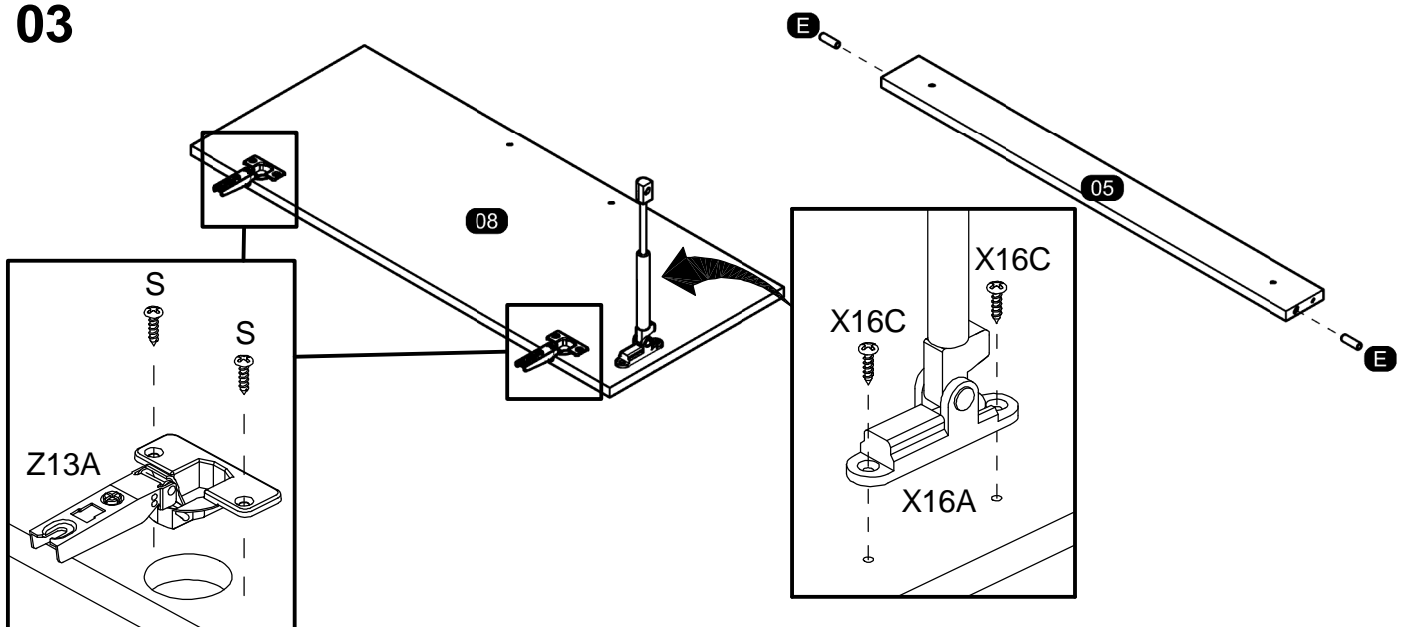

ASSEMBLY
MONTAGEM / ARMADO

04

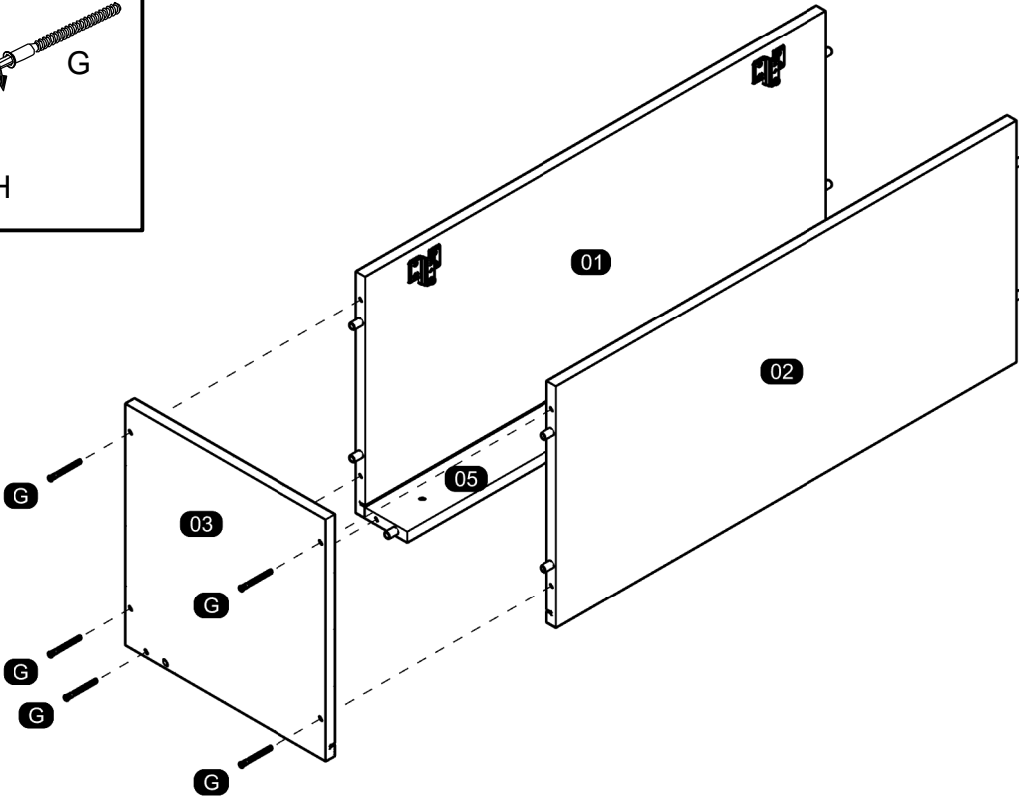
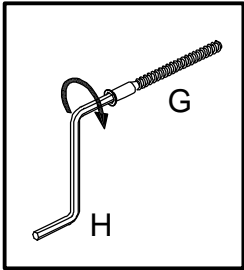

05

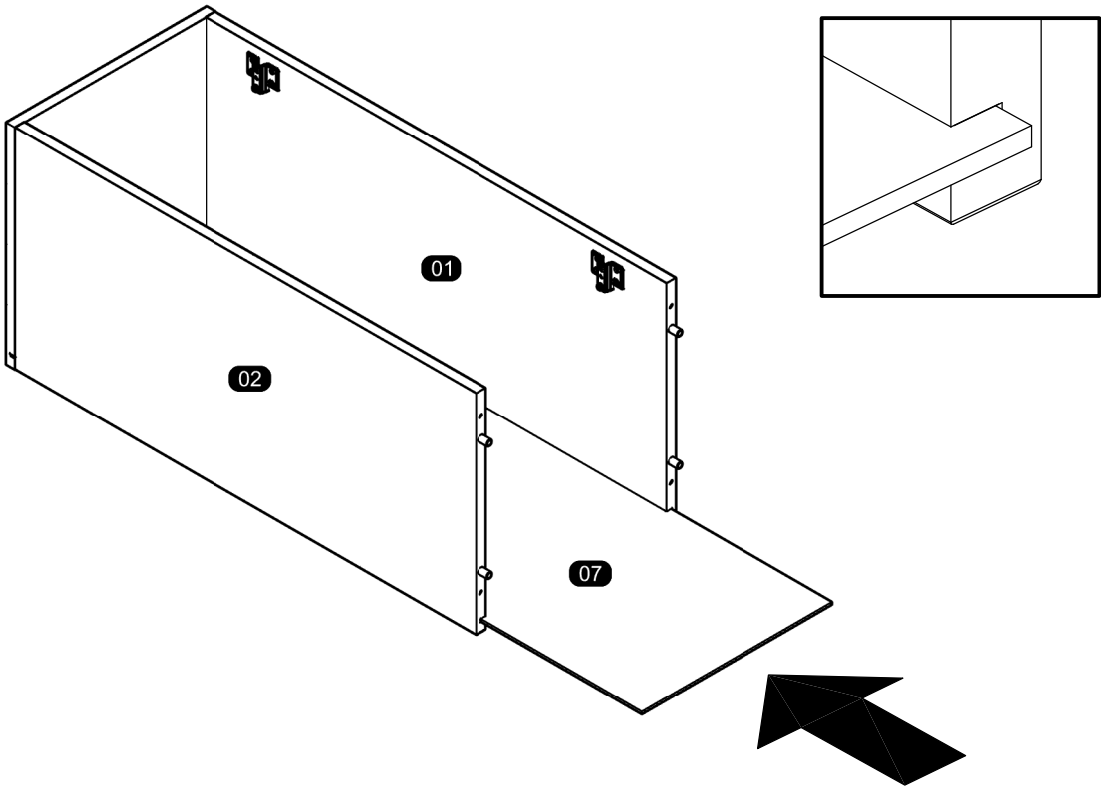

06

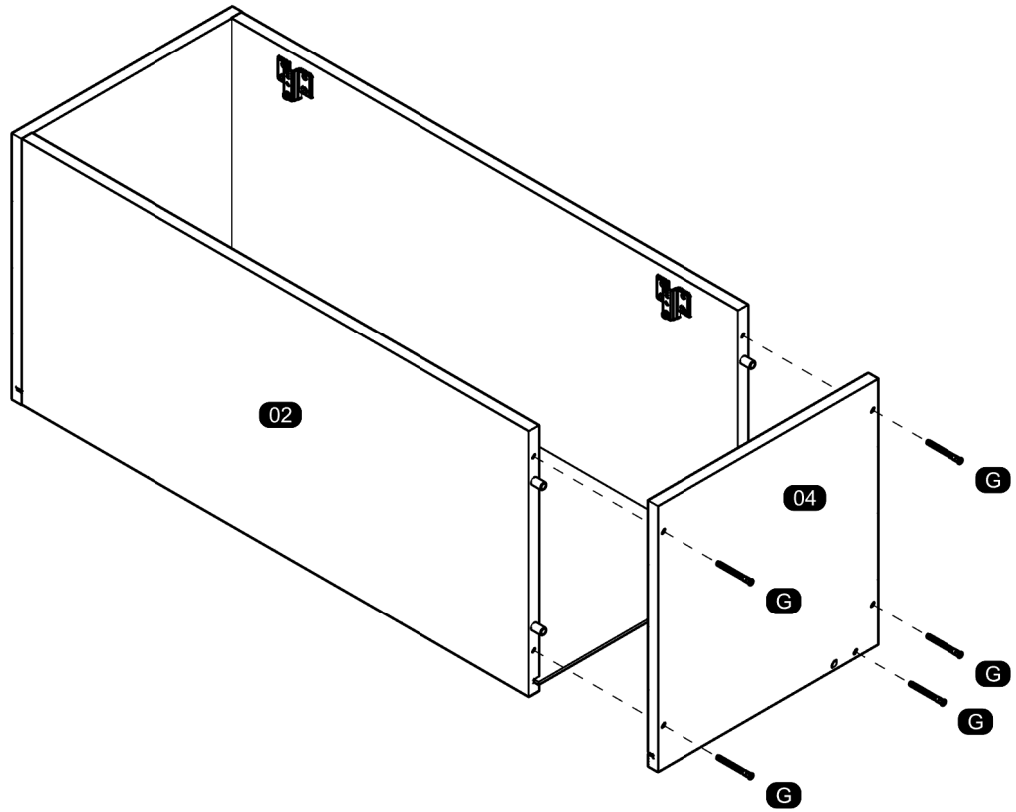

07

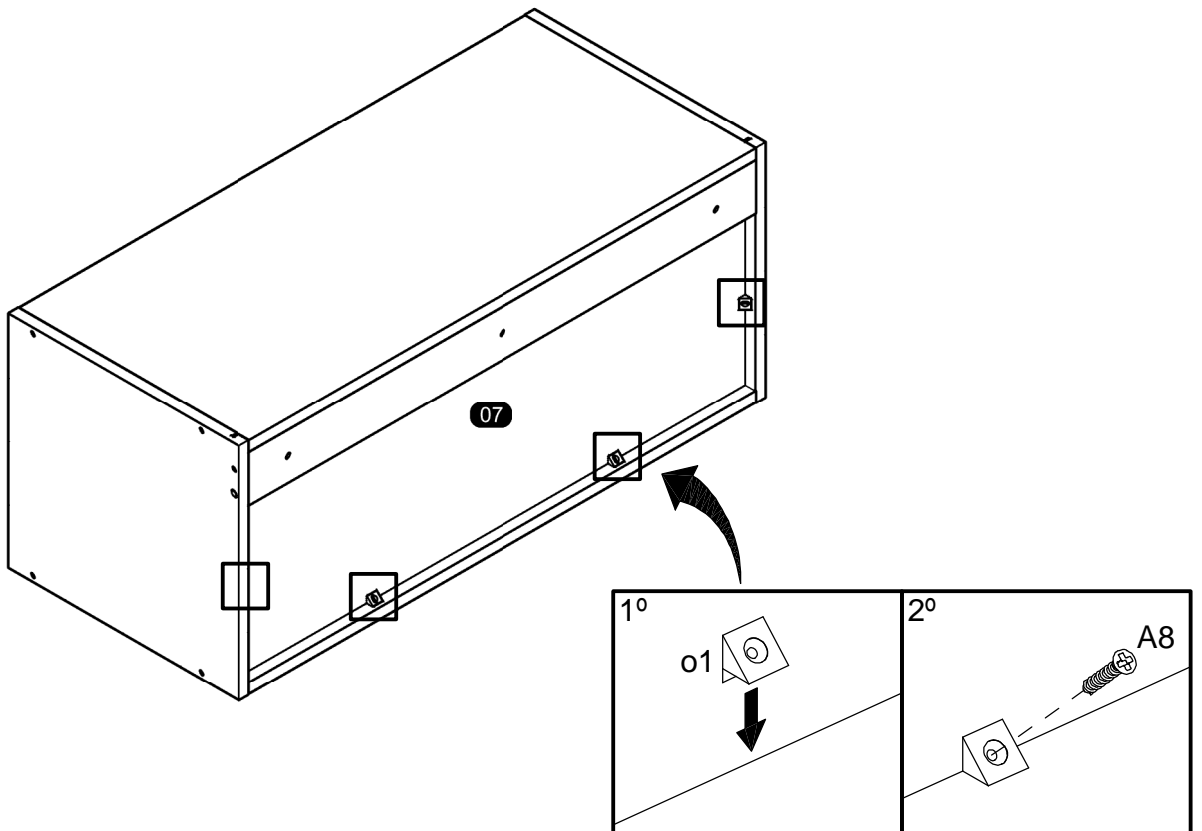

08

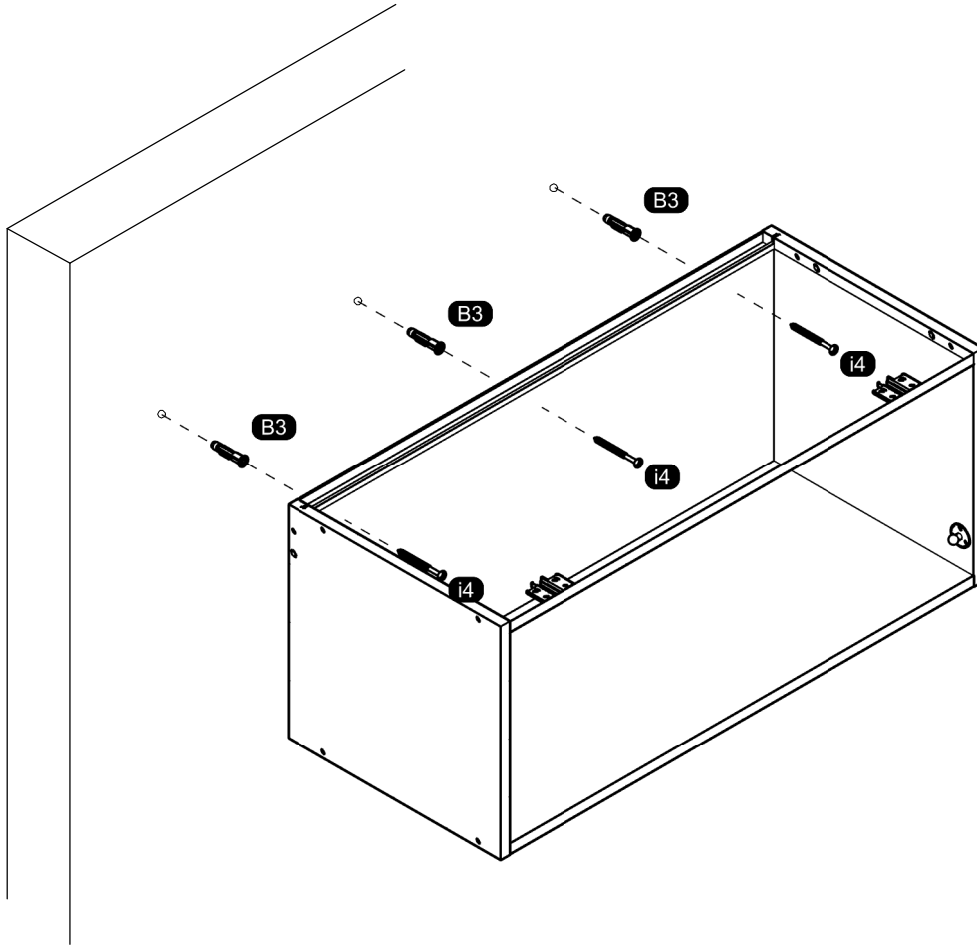

09

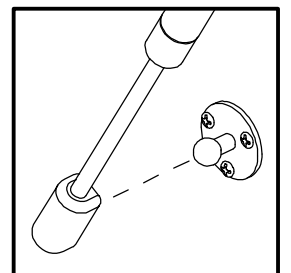
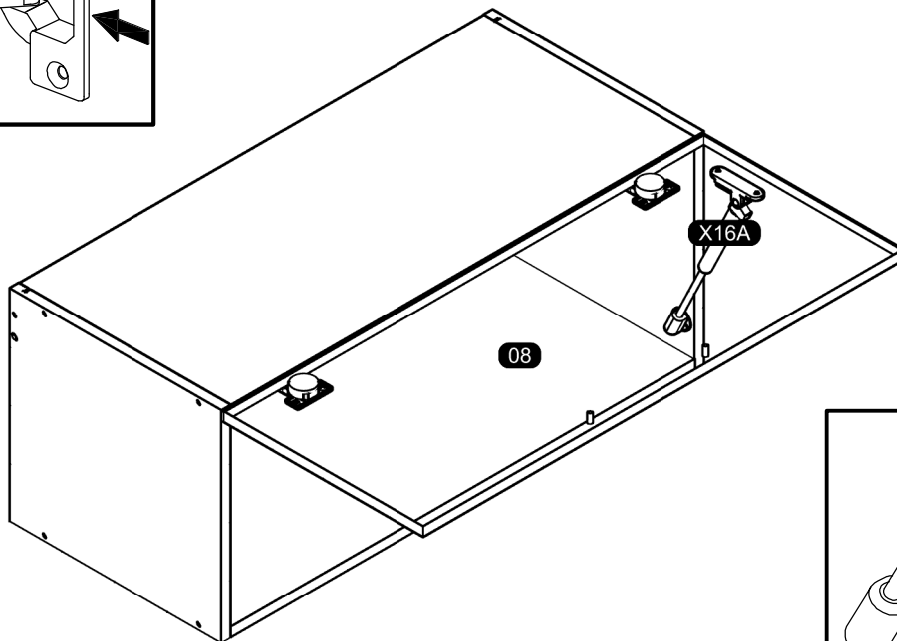
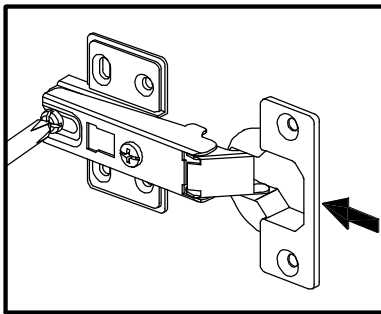

10

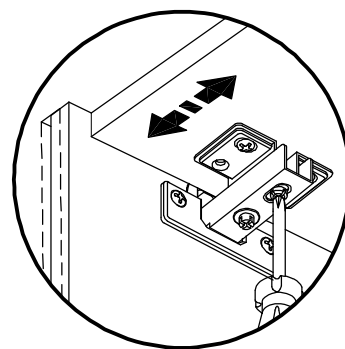
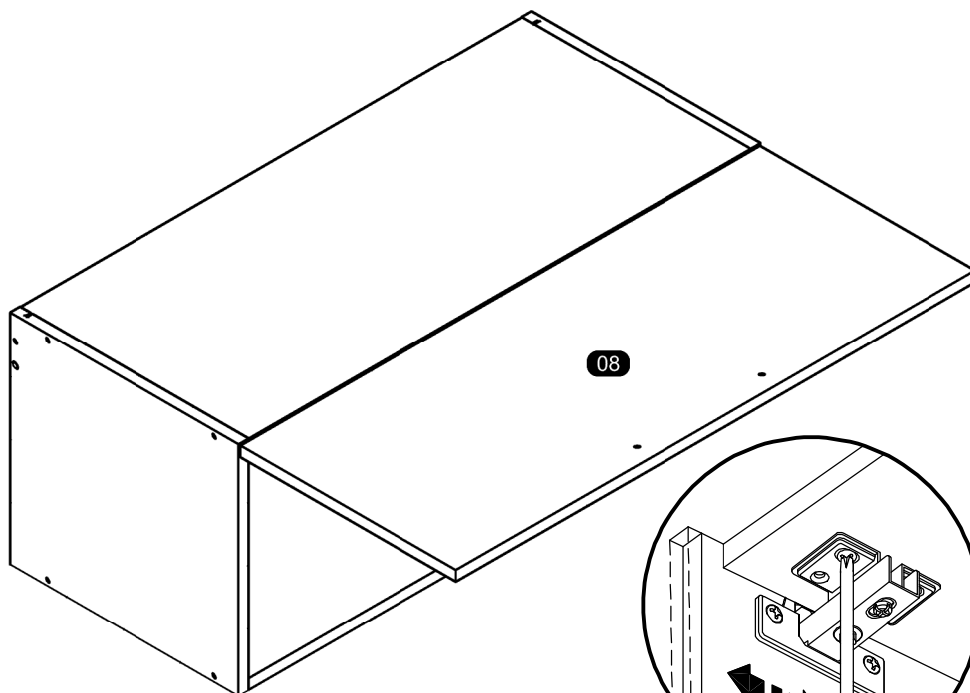

Depth Adjustment
Regulagem Profundidade
Ajuste Profundidade

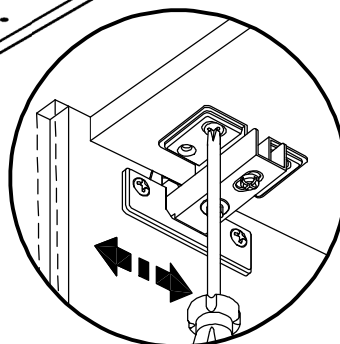

Horizontal Adjustment
Regulagem Horizontal
Ajuste Horizontal

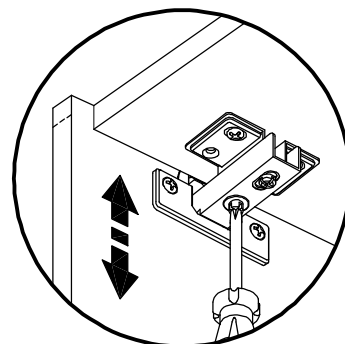

Vertical Adjustment
Regulagem Vertical
Ajuste Vertical

11

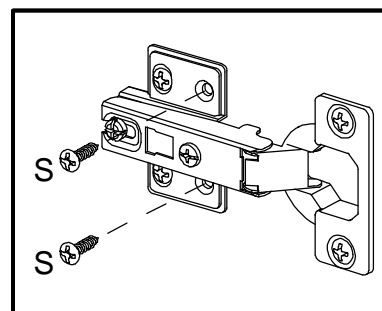
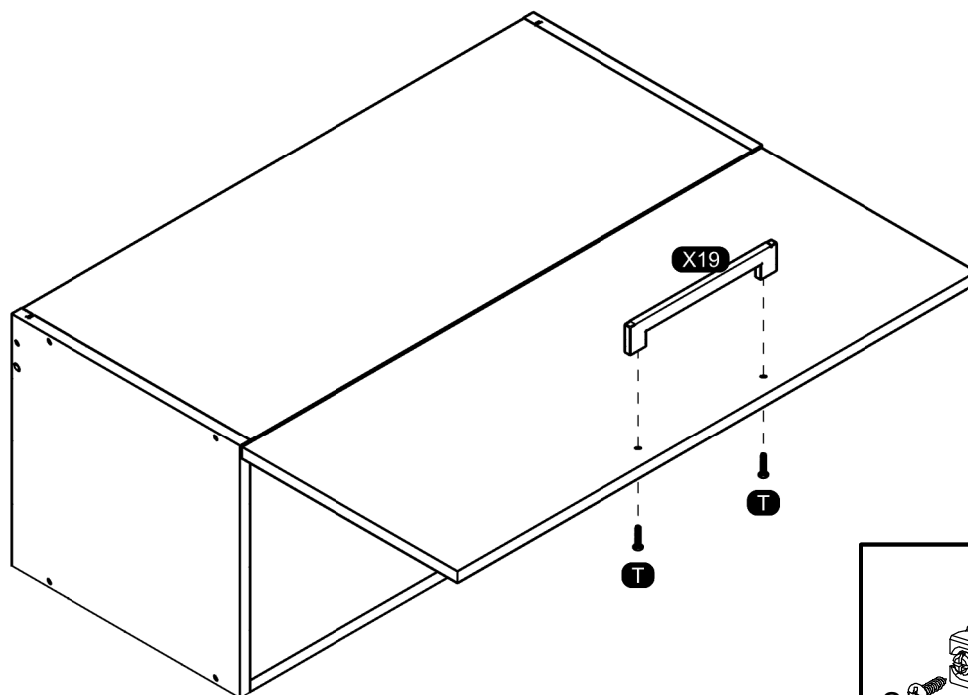

ASSEMBLY INSTRUCTIONS MANUAL DE MONTAGEM / INSTRUCCIONES DE ARMADO

CANELONE WALL CABINET 3 DOORS 47 1/4"

AEREO 3 PORTAS 1200MM CANELONE

ARMARIO DE PARED 3 PUERTAS 1200MM CANELONE

Reference
Referência
Referencia

220366

Revised
Revisão
Revisión

00



ENGLISH
PORTUGUÊS
ESPAÑOL

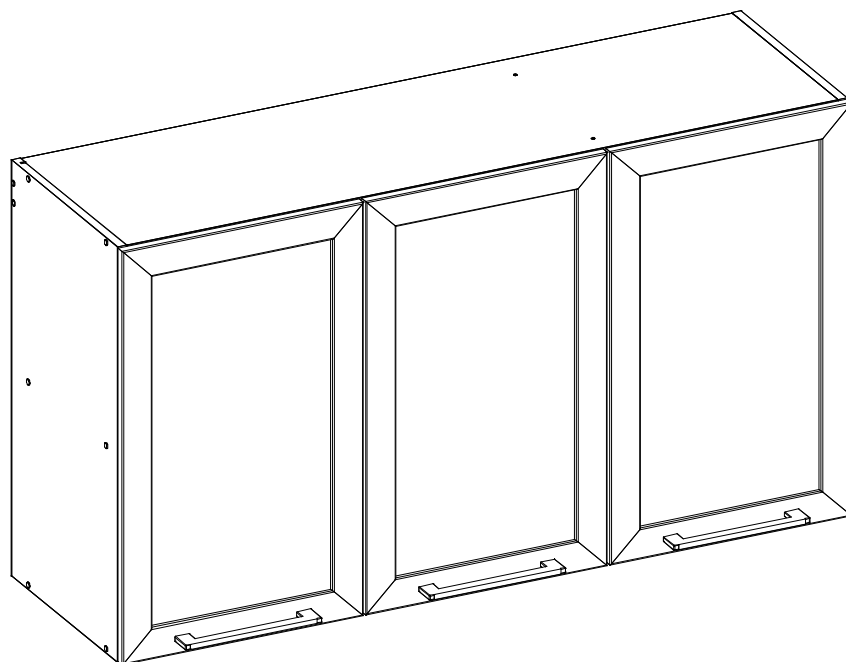

MAXIMUM RECOMMENDED WEIGHT
BEING THIS EVENLY DISTRIBUTED.

PESO MÁXIMO RECOMENDADO SENDO
ESTE DISTRIBUÍDO UNIFORMEMENTE.

PESO MÁXIMO RECOMENDADO SIENDO
ESTE UNIFORMEMENTE DISTRIBUIDO.

| | LB | KG |
|---|----|----|
| — | | |
| F | 22 | 10 |

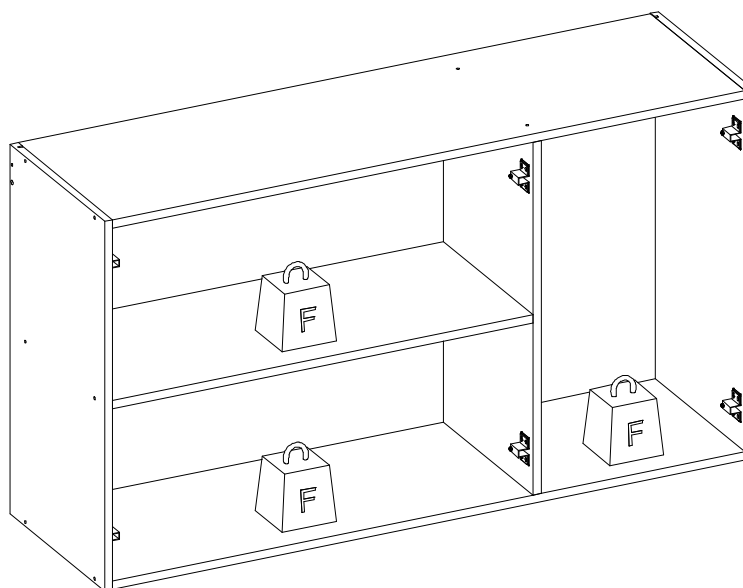

| Nº | Measures_Inches | Medidas_cm | Qty./Qtd. |
|----|-----------------------|--------------------|-----------|
| 01 | 46 1/8 x 13 3/4 x 5/8 | 117.0 x 35.0 x 1.5 | 1 |
| 02 | 30 5/8 x 13 x 5/8 | 77.8 x 33.1 x 1.5 | 1 |
| 03 | 25 1/8 x 13 x 5/8 | 63.9 x 33.1 x 1.5 | 1 |
| 04 | 46 1/8 x 13 3/4 x 5/8 | 117.0 x 35.0 x 1.5 | 1 |
| 05 | 26 3/8 x 13 3/4 x 5/8 | 67.0 x 35.0 x 1.5 | 1 |
| 06 | 26 3/8 x 13 3/4 x 5/8 | 67.0 x 35.0 x 1.5 | 1 |
| 07 | 2 3/4 x 46 1/8 x 5/8 | 7.0 x 117.0 x 1.5 | 1 |
| 08 | 25 3/4 x 15 3/8 x 1/8 | 65.3 x 39.1 x 0.3 | 1 |
| 09 | 31 1/8 x 12 7/8 x 1/8 | 79.2 x 32.6 x 0.3 | 2 |
| 40 | 26 1/4 x 15 5/8 x 5/8 | 66.6 x 39.7 x 1.5 | 3 |

PARTS IDENTIFICATION IDENTIFICAÇÃO DAS PEÇAS / IDENTIFICACIÓN DE LAS PIEZAS

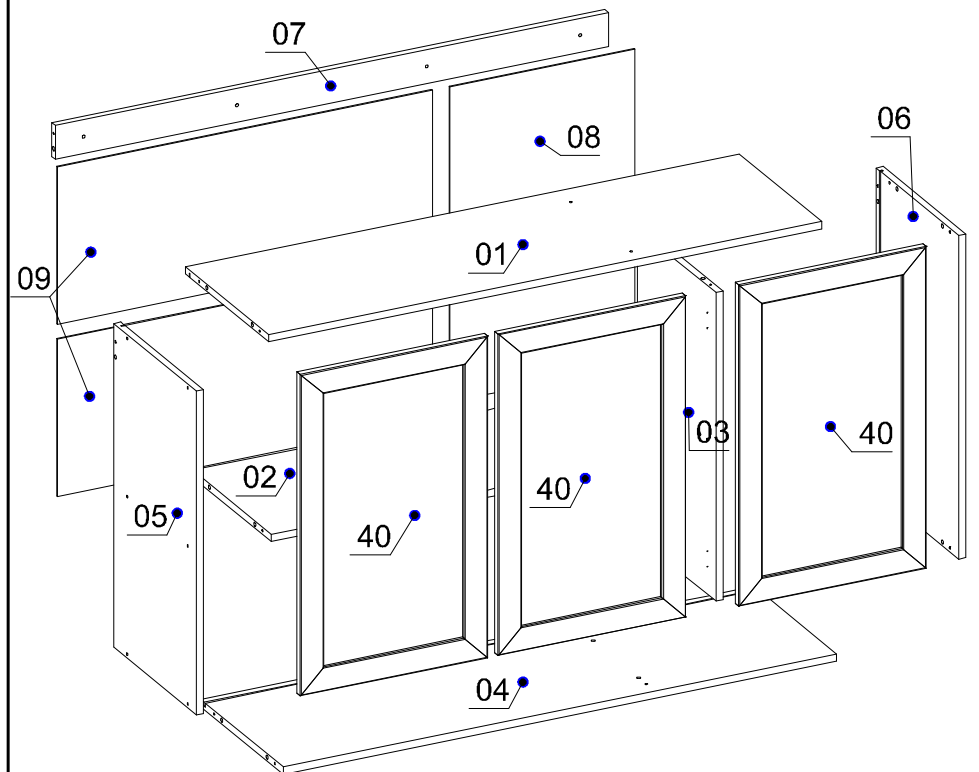

YOU WILL NEED / VOCÊ VAI PRECISAR DE / USTED NECESITARÁ

Tools not supplied / Ferramentas não fornecidas / Herramientas no incluidas

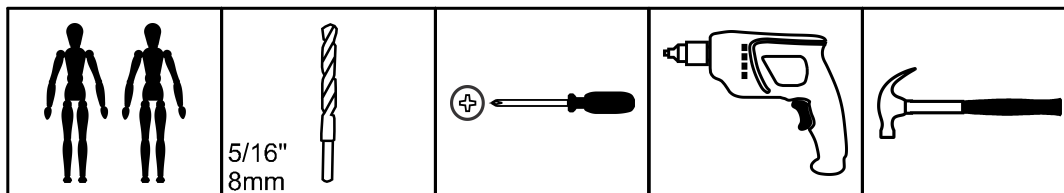

2 People
2 Pessoas
2 Personas

5/16"
8mm
Drill bit
Broca
Taladro

Screwdriver Phillips
Chave Phillips
Destornillador cruz

Drill machine
Furadeira
Taladro

Hammer
Martelo
Martillo











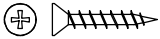
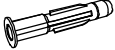

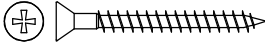
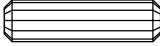
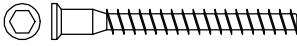

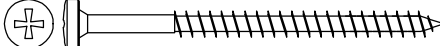
The separation of the accessories before you start the assembly will facilitate the same. In case of doubt on the size of the screws and bolts, use the ruler to bottom of page 3.

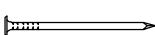
A separação dos acessórios antes de iniciar a montagem facilitará a mesma. Em caso de dúvida no tamanho dos parafusos e cavilhas, utilize a régua ao final da página 3.

La separación de los accesorios antes de comenzar el armado facilitará el mismo. En caso de duda sobre el tamaño de los tornillos y taquetes, utilice la regla al pie de página 3.

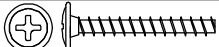
IDENTIFICATION OF ACCESSORIES IDENTIFICAÇÃO DOS ACESSÓRIOS/ IDENTIFICACIÓN DE ACCESORIOS

| | | | | |
|-----|---|--|-----------|----|
| A8 |  | Flat head screw / Parafuso chato / Tornillo de cabeza plana | 3,5x20 mm | 6 |
| B3 |  | Bushing / Bucha expansiva / Tapón | 8x50 mm | 3 |
| C1 |  | Metal claw / Garra de metal / Garra metal | - | 9 |
| D |  | Flat head screw / Parafuso chato / Tornillo de cabeza plana | 4,0x40 mm | 1 |
| E |  | Wooden dowel / Cavilha / Taquete | 8x30 mm | 18 |
| G |  | Structural screw / Parafuso estrutural / Tornillo estructural | 5,0x50 mm | 18 |
| H |  | Allen key / Chave allen / Liave allen | 3 mm | 1 |
| I |  | Structural screw cover/Tampa parafuso estrutural/Tapa tornillo estructural | - | 16 |
| i4 |  | Pan head screw / Parafuso panela / Tornillo de pan | 5,0x70 mm | 3 |
| K11 |  | Silicone stop / Batente de silicone / Tope de silicona | 8 mm | 3 |
| M17 |  | Metal hinge straight / Dobradiça reta / Bisagra recta | 35 mm | 4 |
| N |  | Nail / Pregó / Clavo | 10x10 | 9 |
| N17 |  | Metal hinge straight / Dobradiça curva / Bisagra recta | 35 mm | 2 |
| o1 |  | Triangular support / Suporte triangular / Soporte triangular | - | 6 |
| S |  | Pan head screw / Parafuso panela / Tornillo de pan | 3,5x14 mm | 36 |
| T |  | Flanged head screw / Parafuso flangeado / Tornillo de cabeza flangeada | 3,5x25 mm | 6 |
| X19 |  | Handle / Puxador Citrino / Tirador | 192 mm | 3 |
| Z |  | Plastic hole plugs / Tapa furo plástico / Tapones plásticos | 8 mm | 2 |

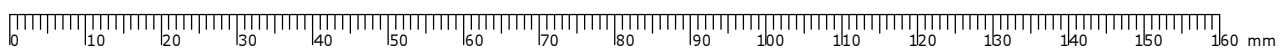

PRE-ASSEMBLE
PRÉ-MONTAGEM / PRE ARMADO

01

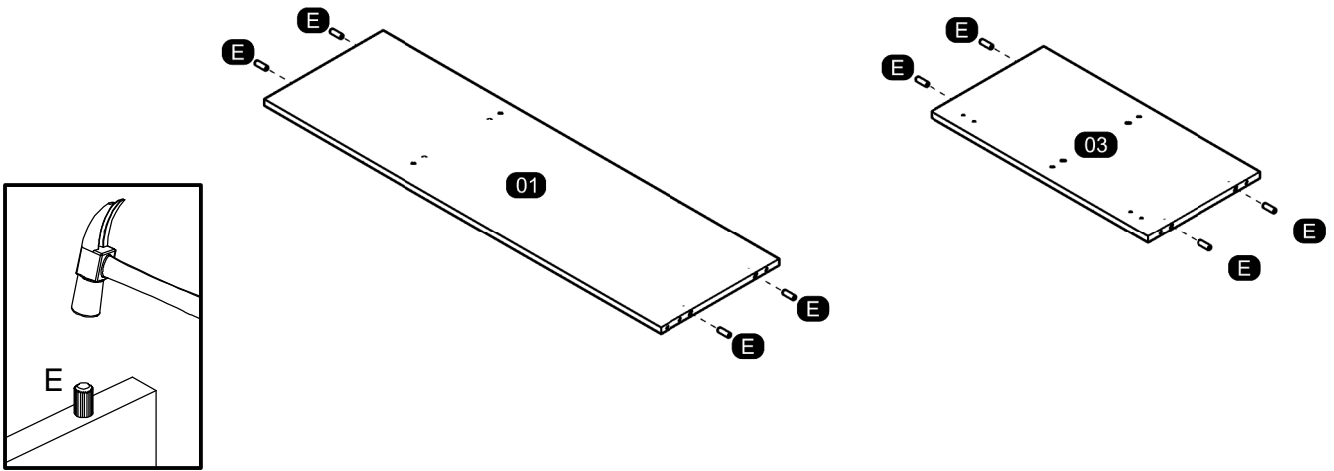

02

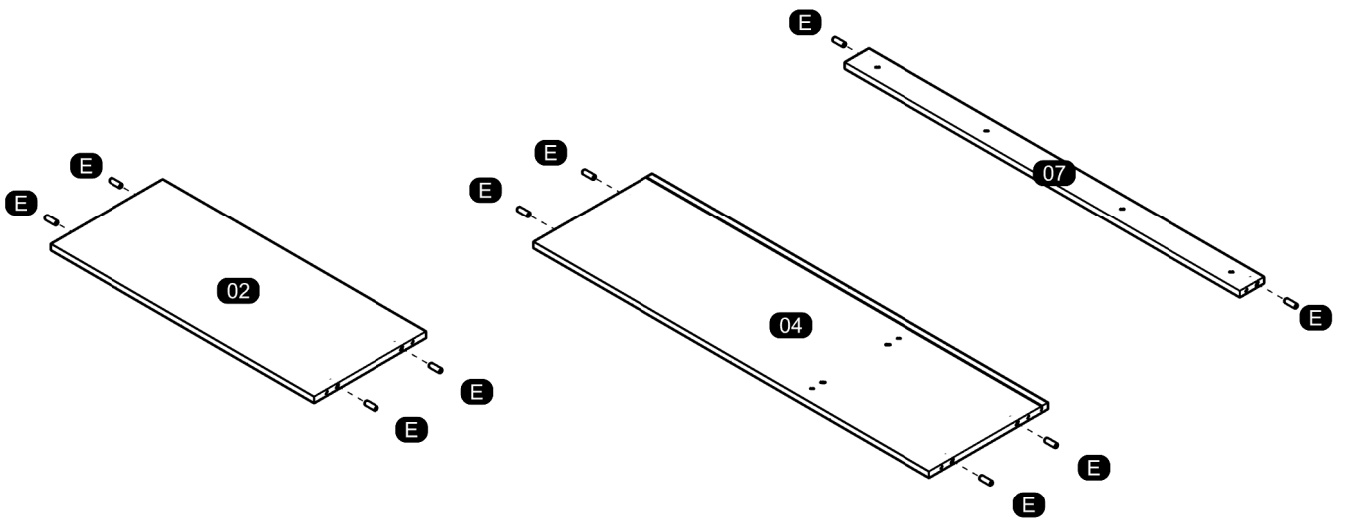

03

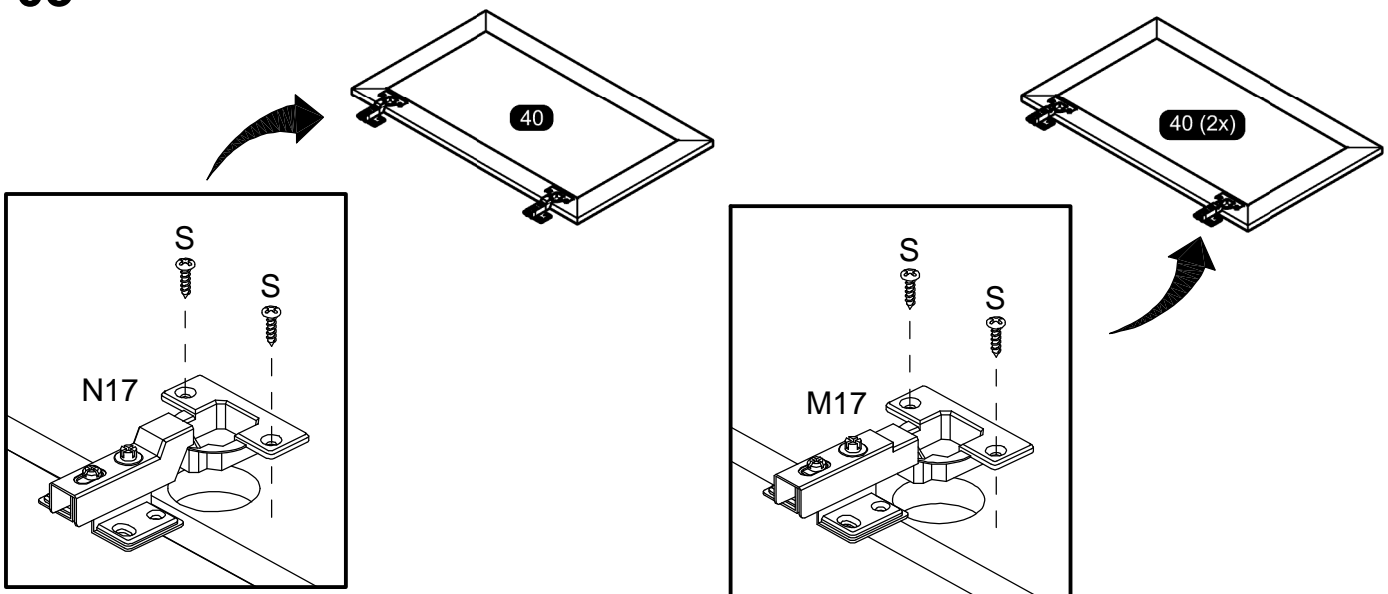

ASSEMBLY
MONTAGEM / ARMADO

04

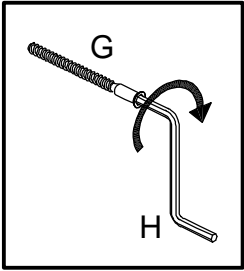
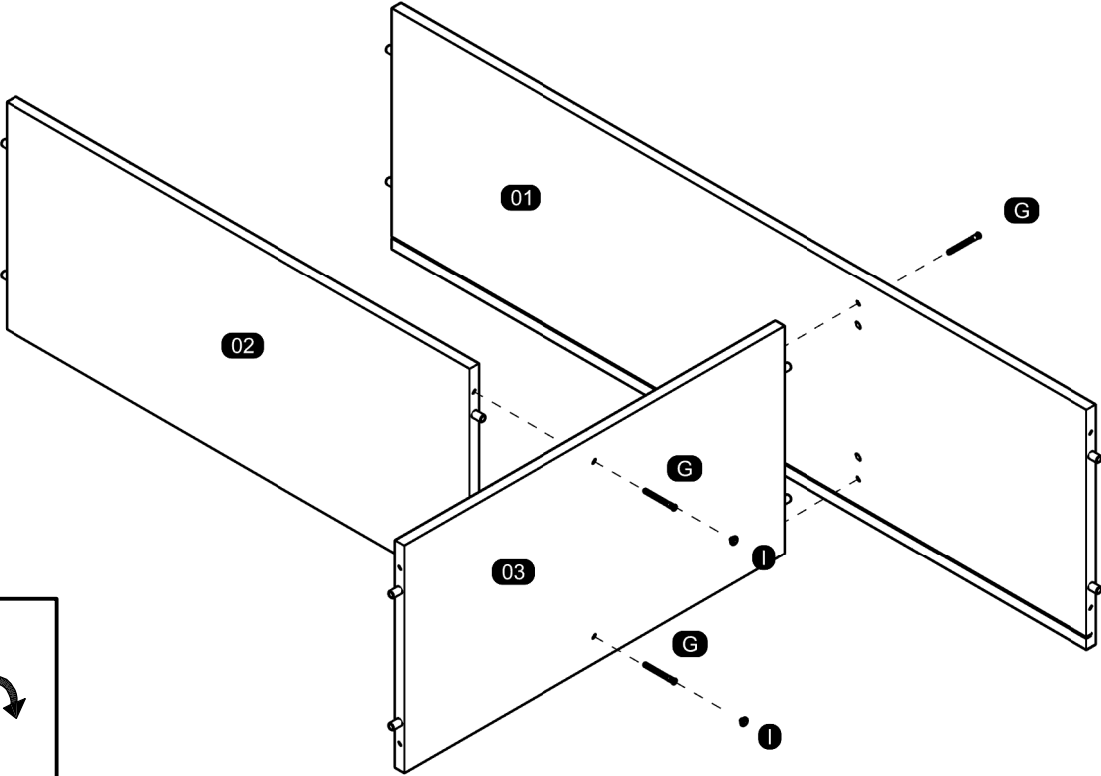

05

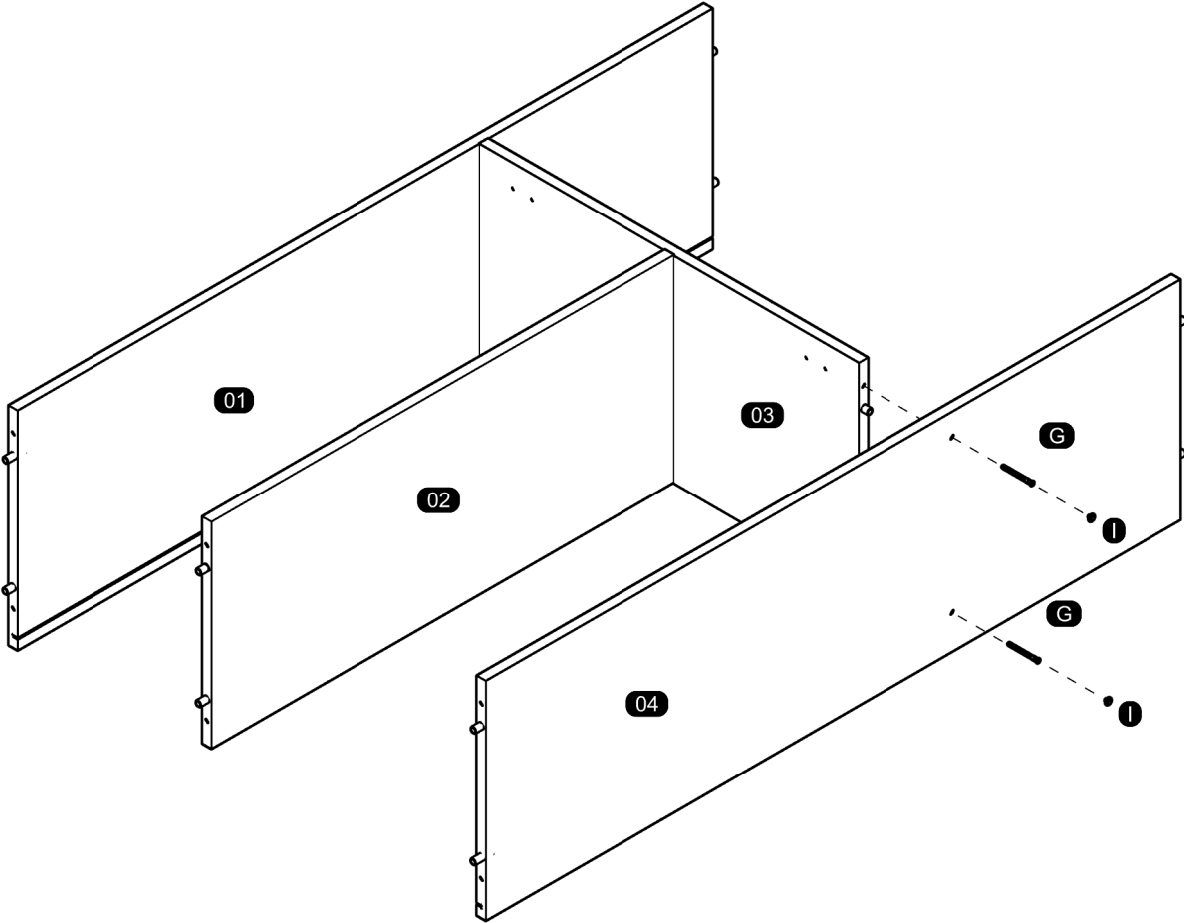

06

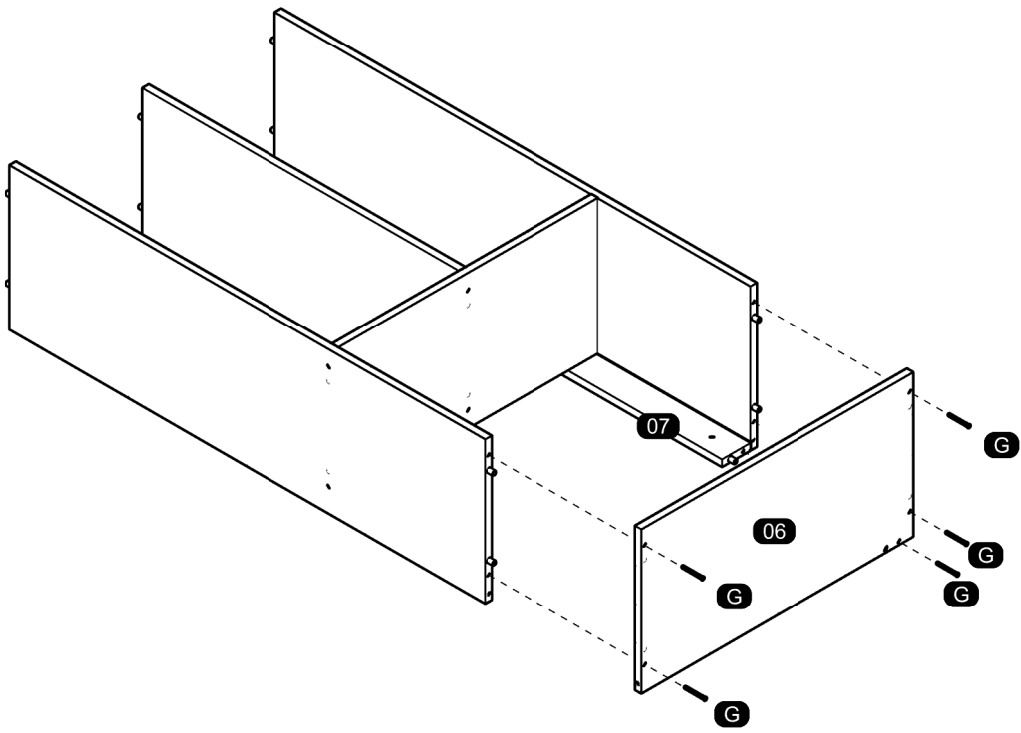

07

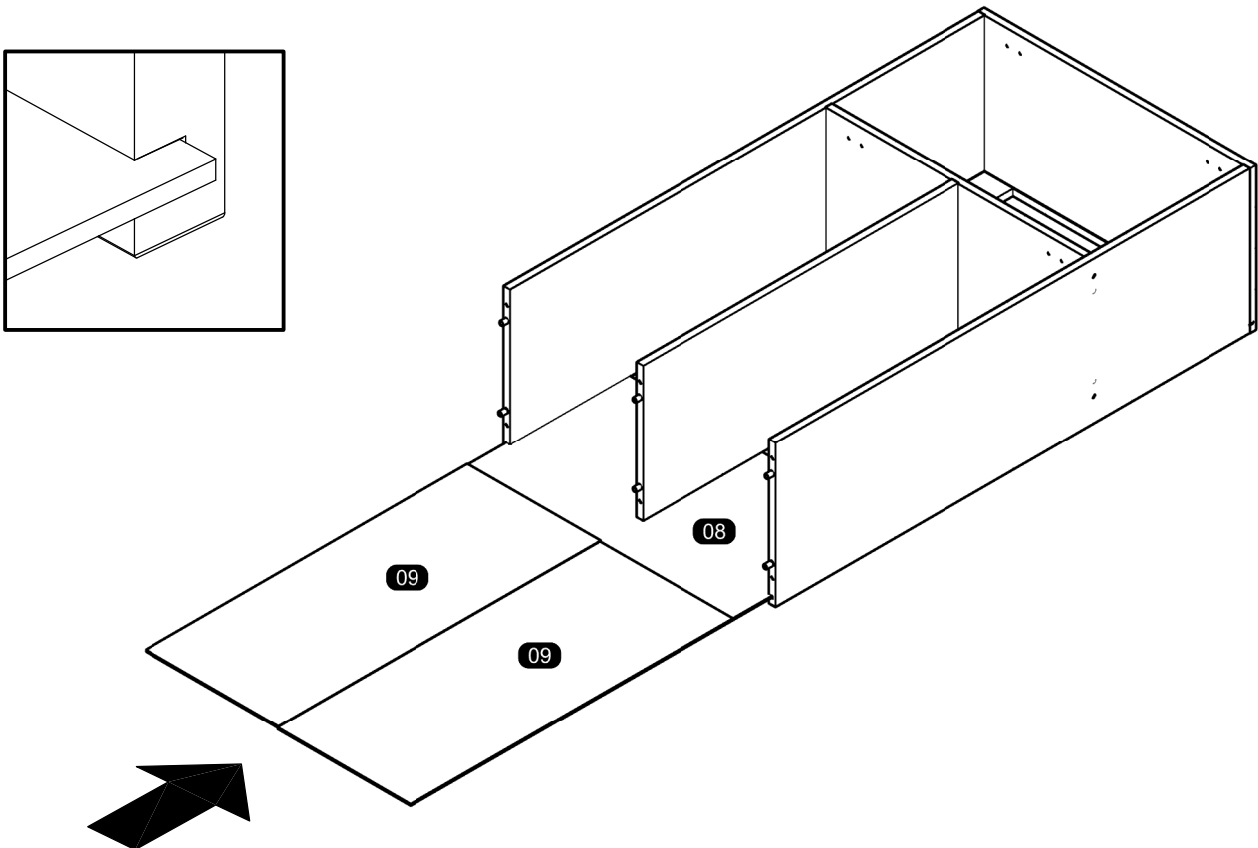

08

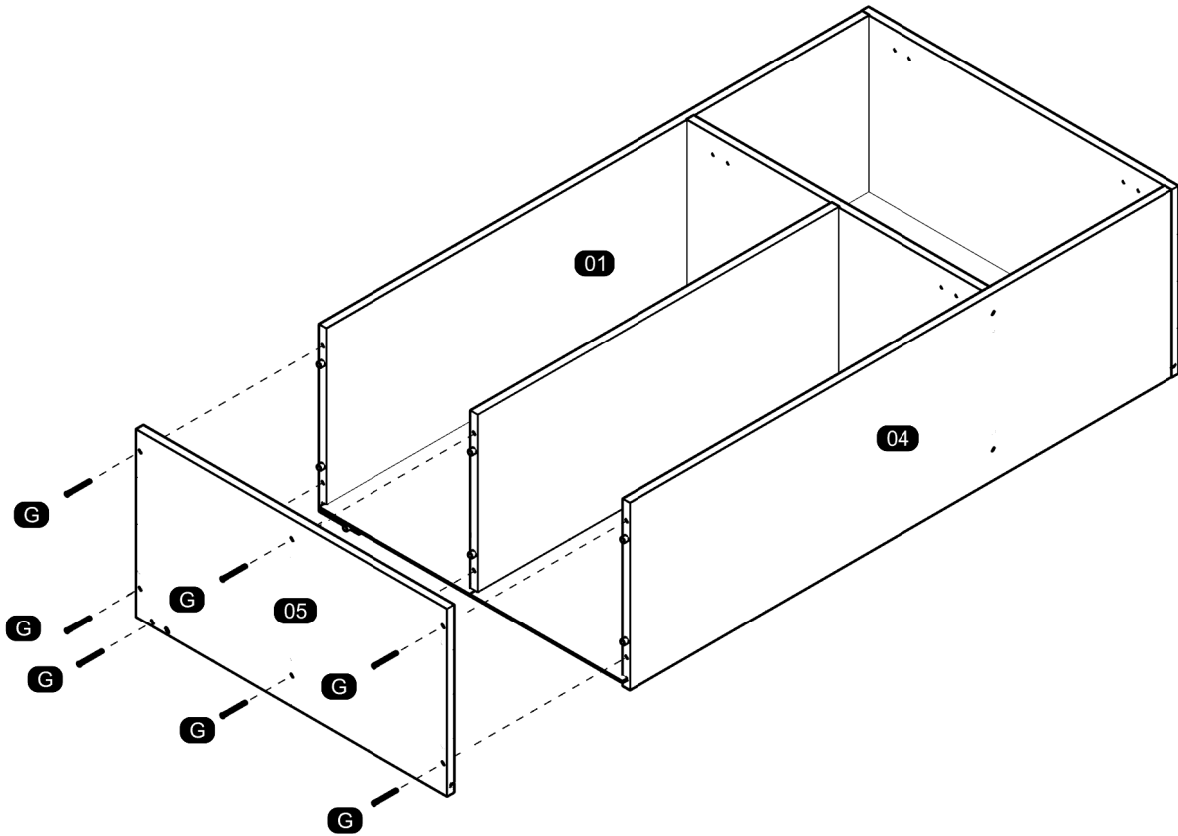

09

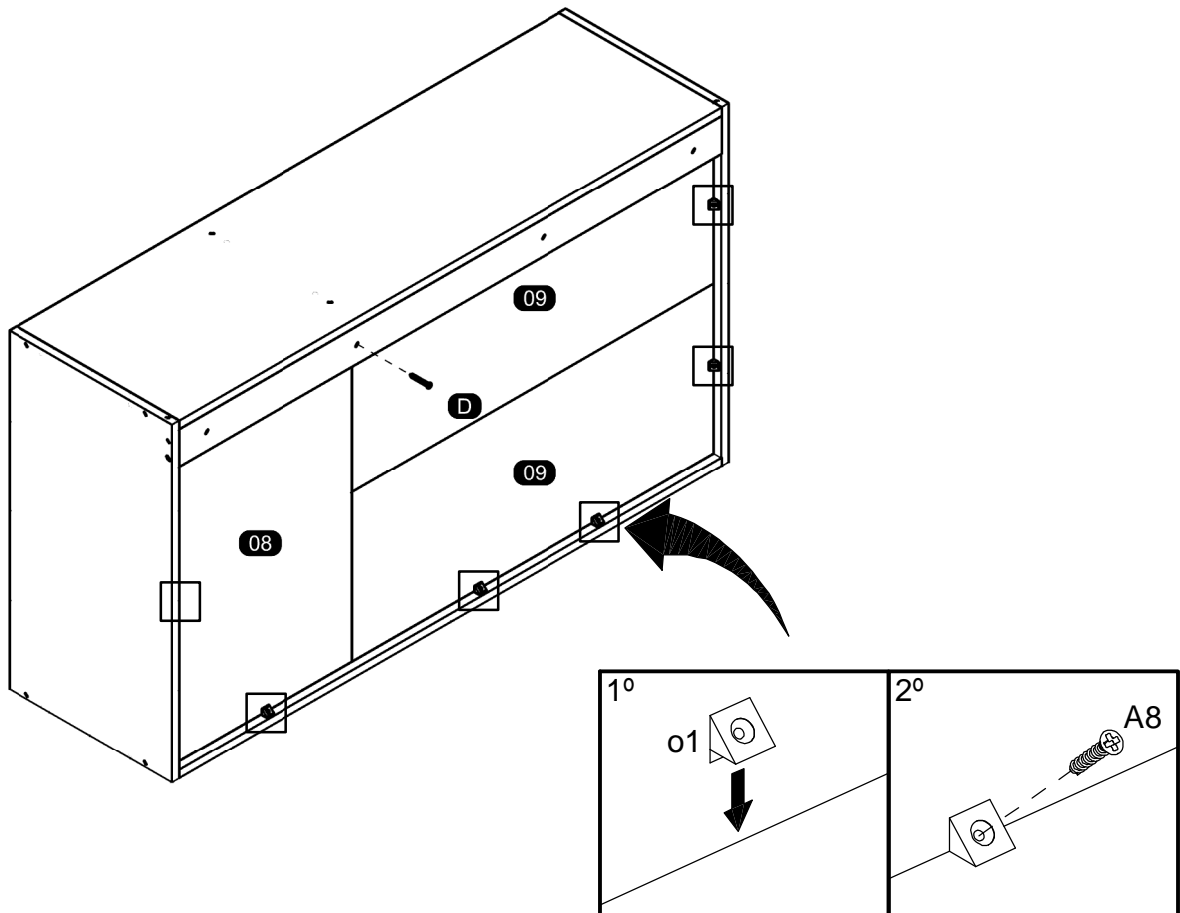

10

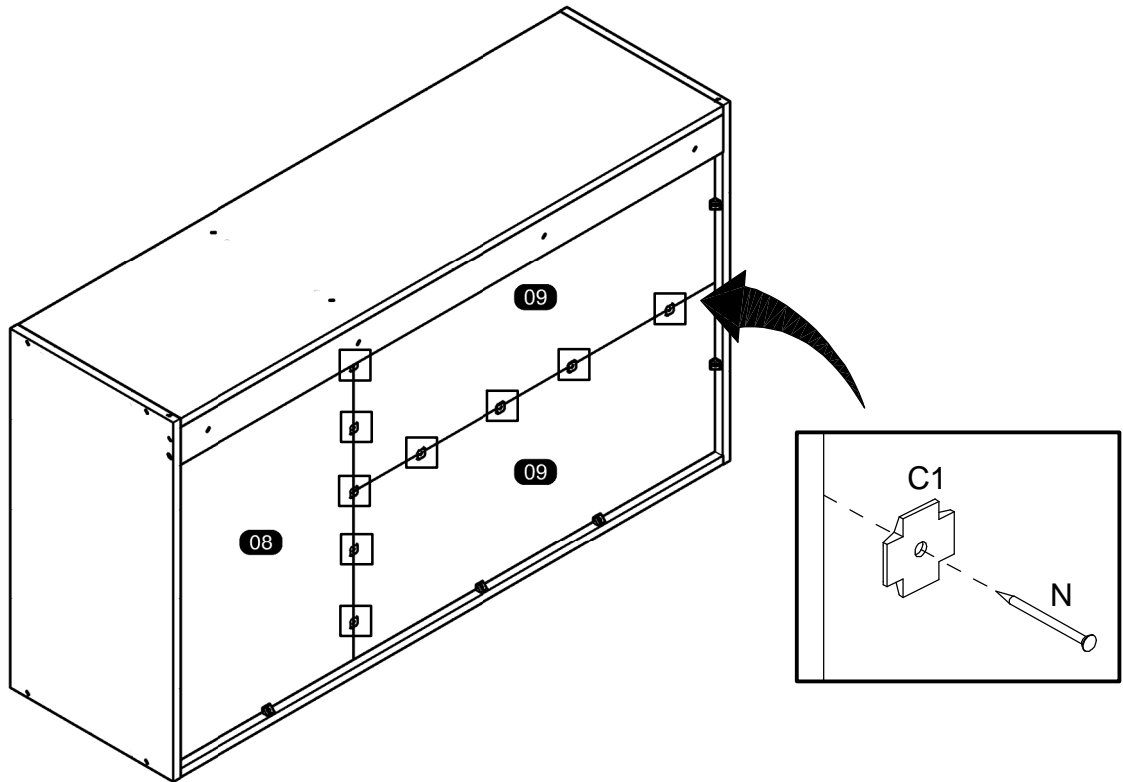

11

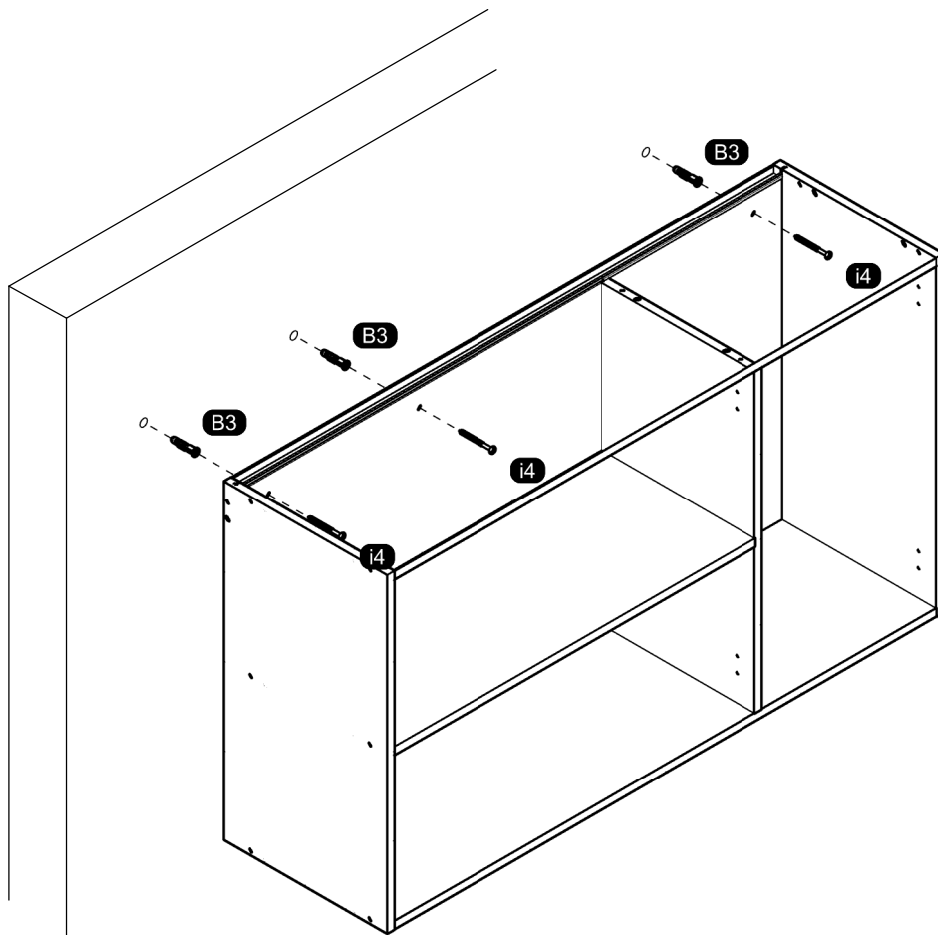

12

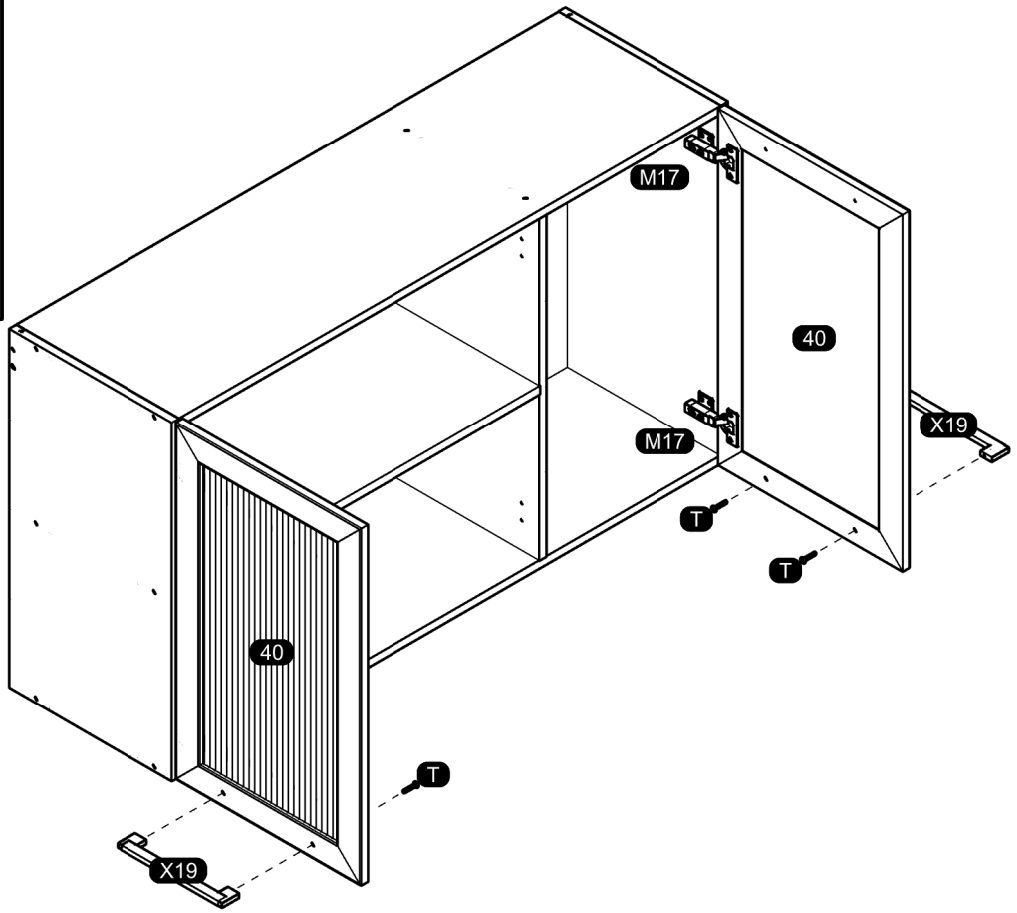
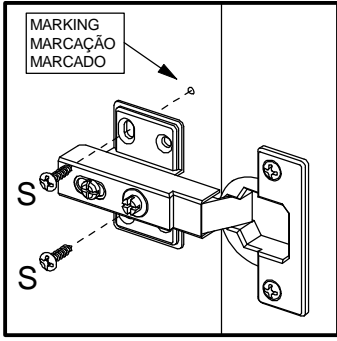

13

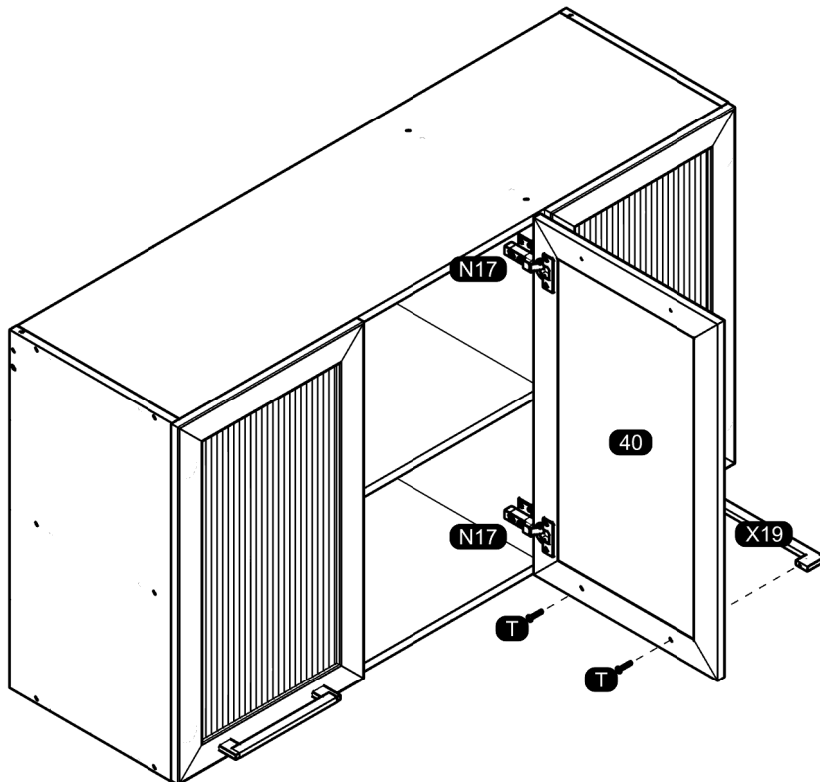

14

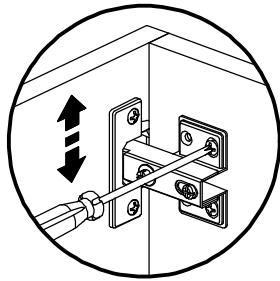

Vertical Adjustment
Regulagem Vertical
Ajuste Vertical

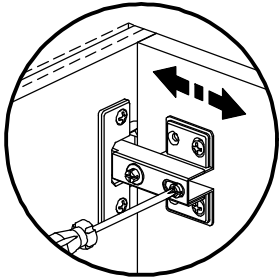

Depth Adjustment
Regulagem Profundidade
Ajuste Profundidad

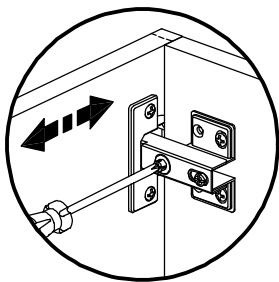

Horizontal Adjustment
Regulagem Horizontal
Ajuste Horizontal

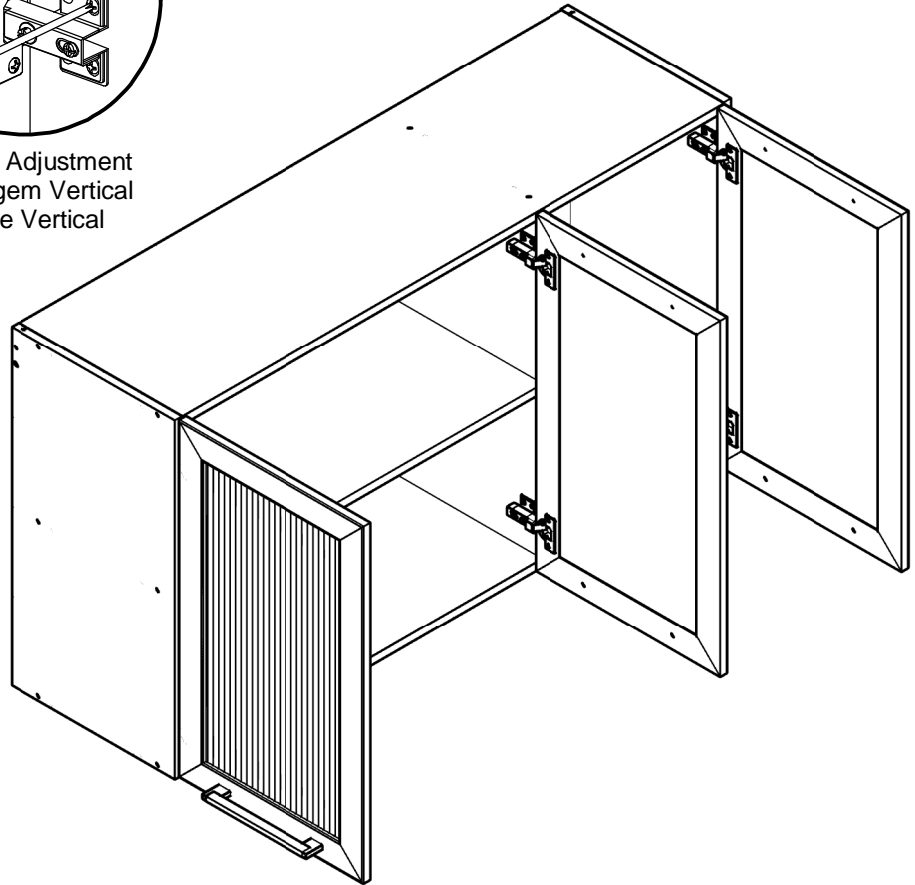

15

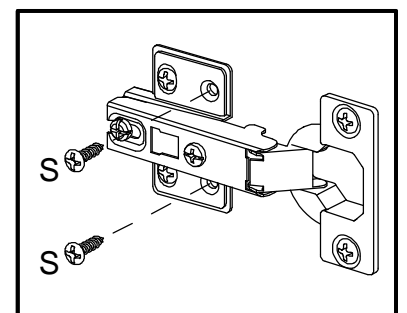
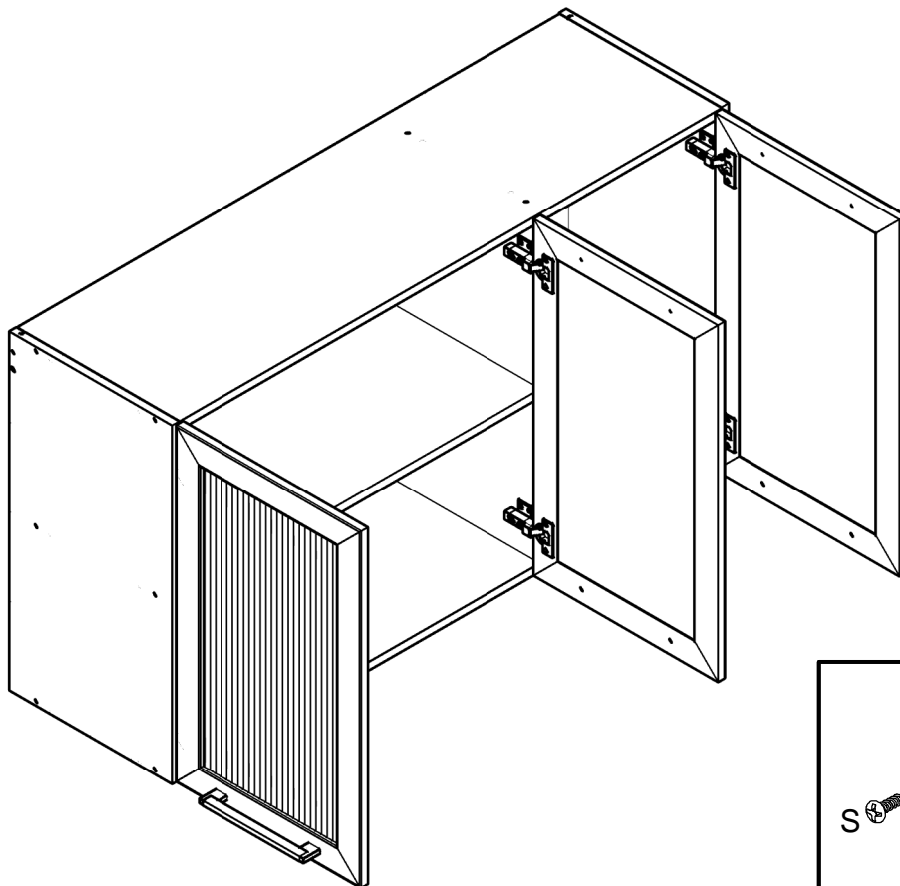

ASSEMBLY INSTRUCTIONS MANUAL DE MONTAGEM / INSTRUCCIONES DE ARMADO

CANELONE PANTRY CABINET 1 DOOR 16"
PANELEIRO 1 PORTA 400MM CANELONE
DESPENSERO 1 PUERTA 400MM CANELONE

Reference
Referência
Referencia

220374

Revisé
Revisão
Revisión

00



ENGLISH
PORTUGUÊS
ESPAÑOL

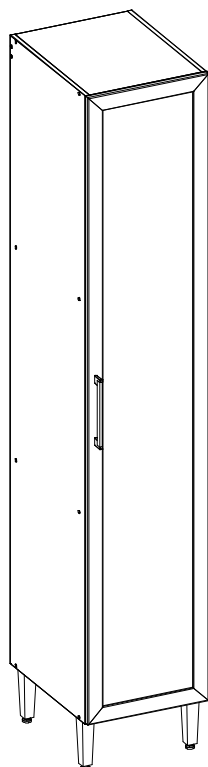

NOTES: THIS PRODUCT CAN BE ASSEMBLED WITH DOOR TO RIGHT OR LEFT.
NOTAS: ESTE PRODUTO PODE SER MONTADO COM A PORTA PARA A SUA DIREITA OU ESQUERDA.
NOTAS: ESTE PRODUCTO SE PUEDE ARMAR CON LA PUERTA A LA DERECHA O IZQUIERDA.



MAXIMUM RECOMMENDED WEIGHT
BEING THIS EVENLY DISTRIBUTED.

PESO MÁXIMO RECOMENDADO SENDO
ESTE DISTRIBUÍDO UNIFORMEMENTE.

PESO MÁXIMO RECOMENDADO SIENDO
ESTE UNIFORMEMENTE DISTRIBUIDO.

| | LB | KG |
|---|----|----|
| – | | |
| D | 11 | 5 |
| F | 22 | 10 |

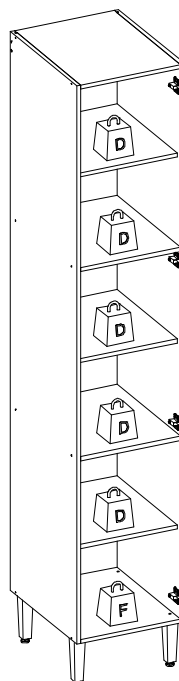

| Nº | Measures_Inches | Medidas_cm | Qty./Qtd. |
|----|-----------------------|--------------------|-----------|
| 01 | 14 5/8 x 19 1/4 x 5/8 | 37.0 x 49.0 x 1.5 | 1 |
| 02 | 14 5/8 x 17 1/2 x 5/8 | 37.0 x 44.5 x 1.5 | 3 |
| 03 | 14 5/8 x 18 1/2 x 5/8 | 37.0 x 47.1 x 1.5 | 2 |
| 04 | 14 5/8 x 19 1/4 x 5/8 | 37.0 x 49.0 x 1.5 | 1 |
| 05 | 79 5/8 x 19 1/4 x 5/8 | 202.4 x 49.0 x 1.5 | 1 |
| 06 | 2 3/4 x 14 5/8 x 5/8 | 7.0 x 37.0 x 1.5 | 1 |
| 07 | 79 5/8 x 19 1/4 x 5/8 | 202.4 x 49.0 x 1.5 | 1 |
| 10 | 79 x 15 1/8 x 1/8 | 200.8 x 38.4 x 0.3 | 1 |
| 41 | 79 1/2 x 15 5/8 x 5/8 | 202.0 x 39.7 x 1.5 | 1 |

PARTS IDENTIFICATION IDENTIFICAÇÃO DAS PEÇAS / IDENTIFICACIÓN DE LAS PIEZAS

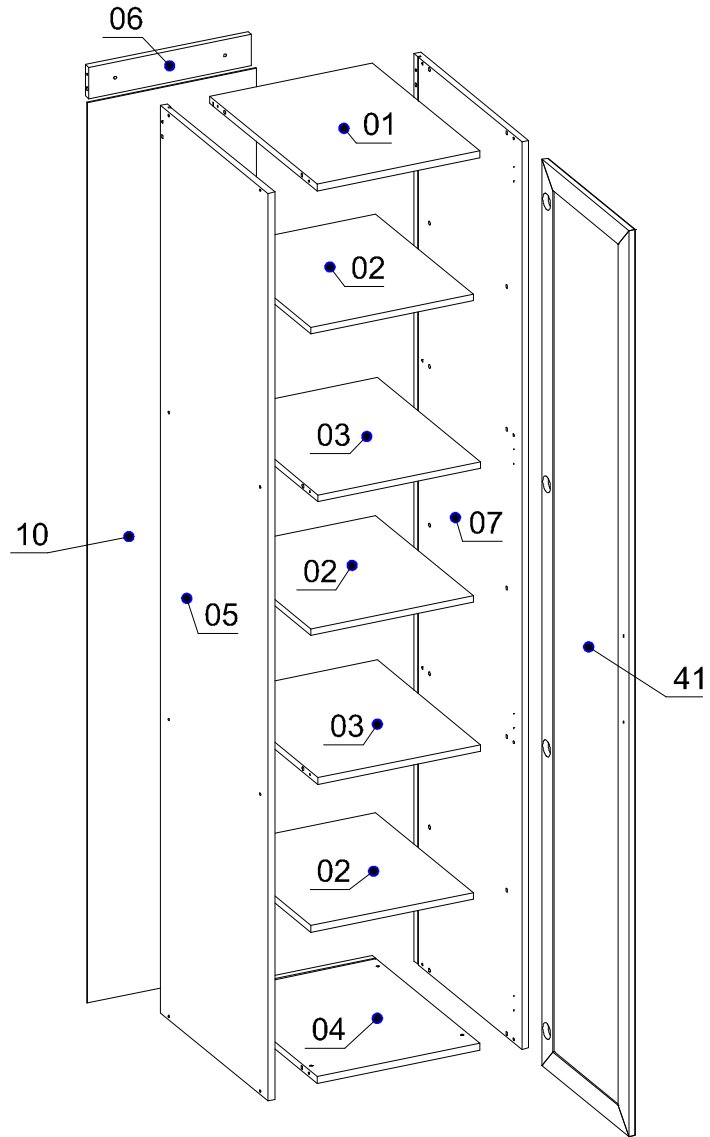

YOU WILL NEED / VOCÊ VAI PRECISAR DE / USTED NECESITARÁ

Tools not supplied / Ferramentas não fornecidas / Herramientas no incluidas

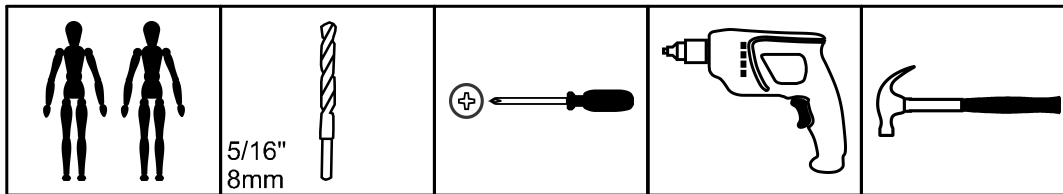

2 People
2 Pessoas
2 Personas

5/16"
8mm
Drill bit
Broca
Taladro

Screwdriver Phillips
Chave Phillips
Destornillador cruz

Drill machine
Furadeira
Taladro

Hammer
Martelo
Martillo











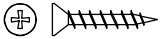
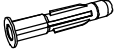
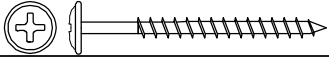
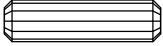

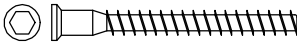

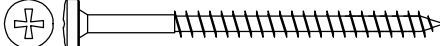
The separation of the accessories before you start the assembly will facilitate the same. In case of doubt on the size of the screws and bolts, use the ruler to bottom of page 3.

A separação dos acessórios antes de iniciar a montagem facilitará a mesma. Em caso de dúvida no tamanho dos parafusos e cavilhas, utilize a régua ao final da página 3.

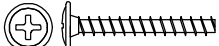
La separación de los accesorios antes de comenzar el armado facilitará el mismo. En caso de duda sobre el tamaño de los tornillos y taquetes, utilice la regla al pie de página 3.

IDENTIFICATION OF ACCESSORIES IDENTIFICAÇÃO DOS ACESSÓRIOS/ IDENTIFICACIÓN DE ACCESORIOS

| | | | | |
|-----|---|--|-----------|----|
| A8 |  | Flat head screw / Parafuso chato / Tornillo de cabeza plana | 3,5x20 mm | 5 |
| B3 |  | Bushing / Bucha expansiva / Tapón | 8x50 mm | 2 |
| C |  | Flanged head screw / Parafuso flangeado / Tornillo de cabeza flangeada | 4,5x45 mm | 4 |
| E |  | Wooden dowel / Cavilha / Taquete | 8x30 mm | 18 |
| E3 |  | Shelf bracket / Suporte de prateleira / Suporte de repisa | 8x7 mm | 12 |
| G |  | Structural screw / Parafuso estrutural / Tornillo estructural | 5,0x50 mm | 18 |
| H |  | Allen key / Chave allen / Liave allen | 3 mm | 1 |
| I |  | Structural screw cover/Tampa parafuso estrutural/Tapa tornillo estructural | - | 18 |
| i4 |  | Pan head screw / Parafuso panela / Tornillo de pan | 5,0x70 mm | 2 |
| K11 |  | Silicone stop / Batente de silicone / Tope de silicona | 8 mm | 2 |
| M17 |  | Metal hinge straight / Dobradiça reta / Bisagra recta | 35 mm | 4 |
| o1 |  | Triangular support / Suporte triangular / Soporte triangular | - | 5 |
| S |  | Pan head screw / Parafuso panela / Tornillo de pan | 3,5x14 mm | 24 |
| T |  | Flanged head screw / Parafuso flangeado / Tornillo de cabeza flangeada | 3,5x25 mm | 2 |
| X15 |  | Foot / Pé Cônico FP / Pie | 170 mm | 4 |
| X19 |  | Handle / Puxador Citrino / Tirador | 192 mm | 1 |
| Z |  | Plastic hole plugs / Tapa furo plástico / Tapones plásticos | 8 mm | 2 |



PRE-ASSEMBLE
PRÉ-MONTAGEM / PRE ARMADO

01

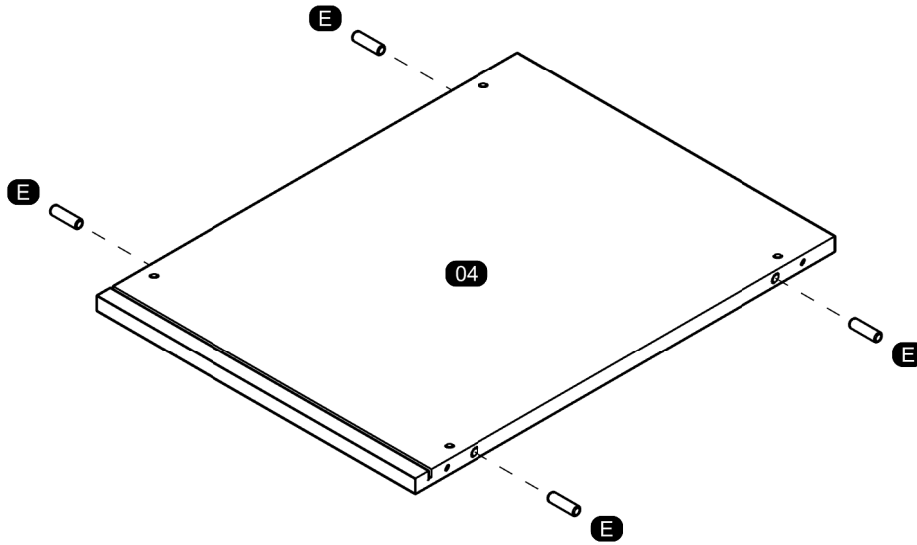
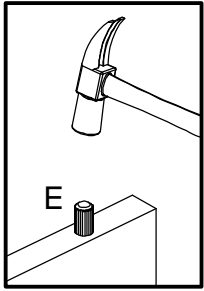

02

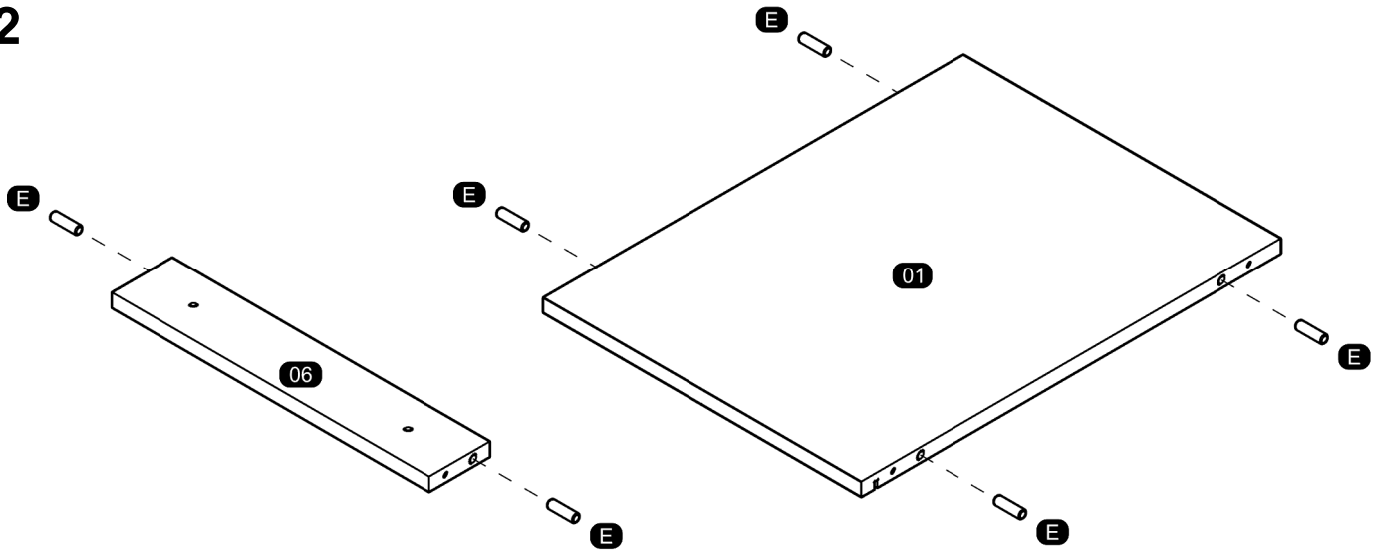

03

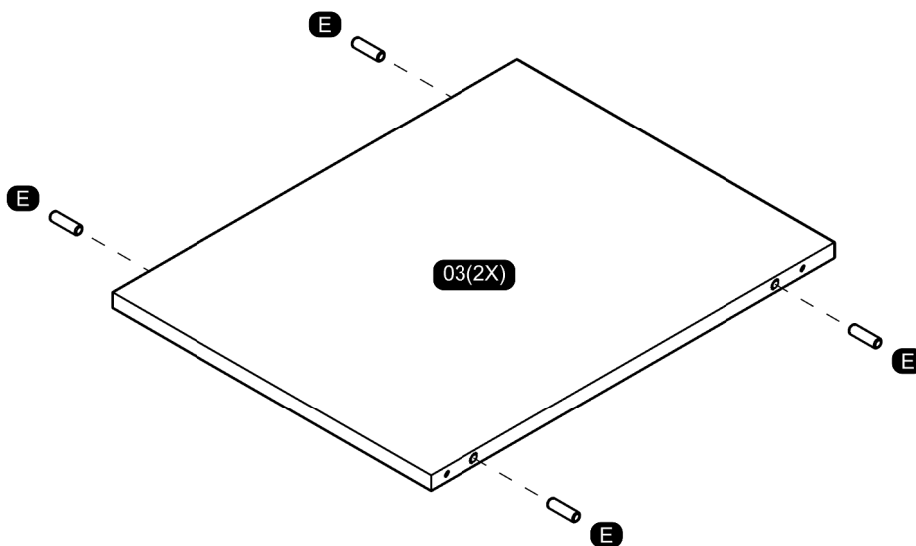

04

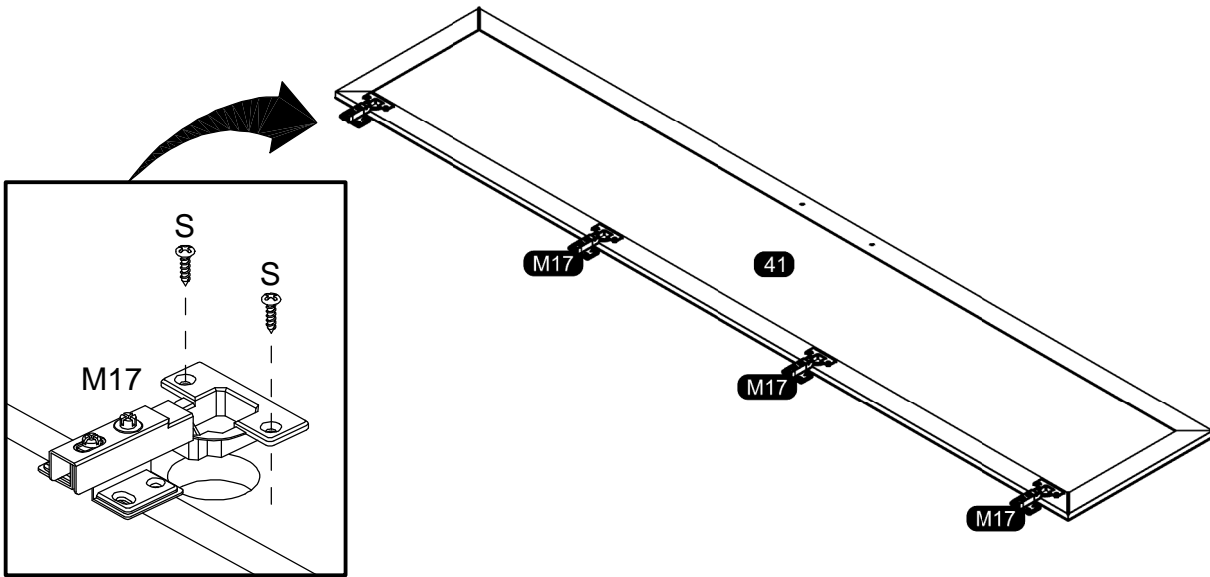

05

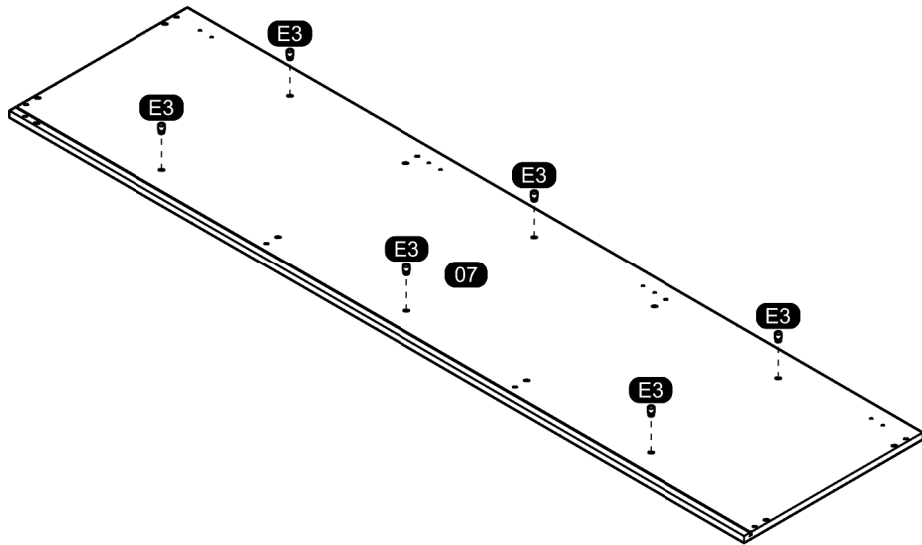

06

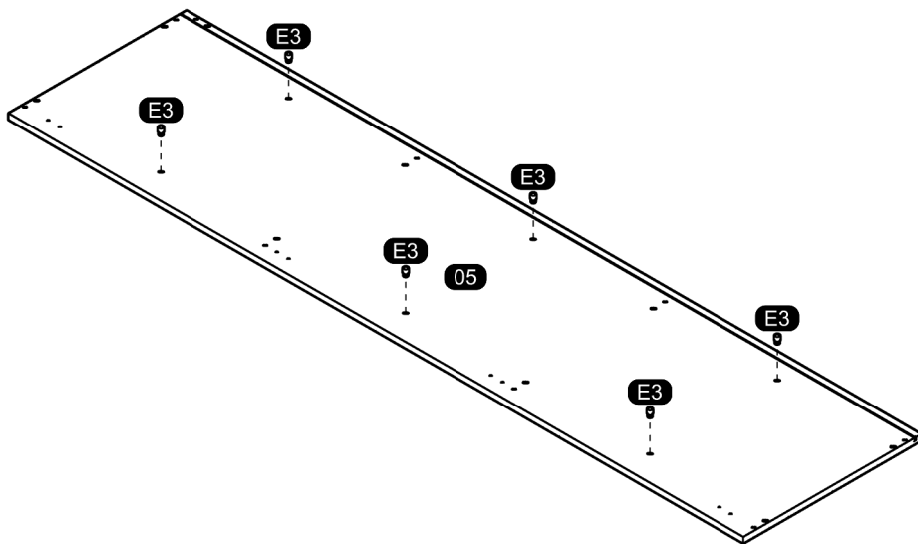

ASSEMBLY
MONTAGEM / ARMADO

07

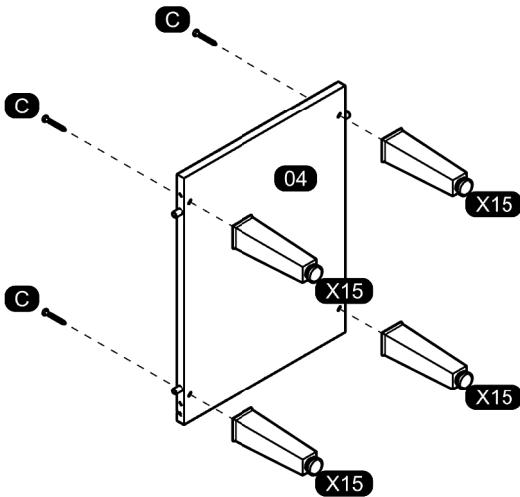

08

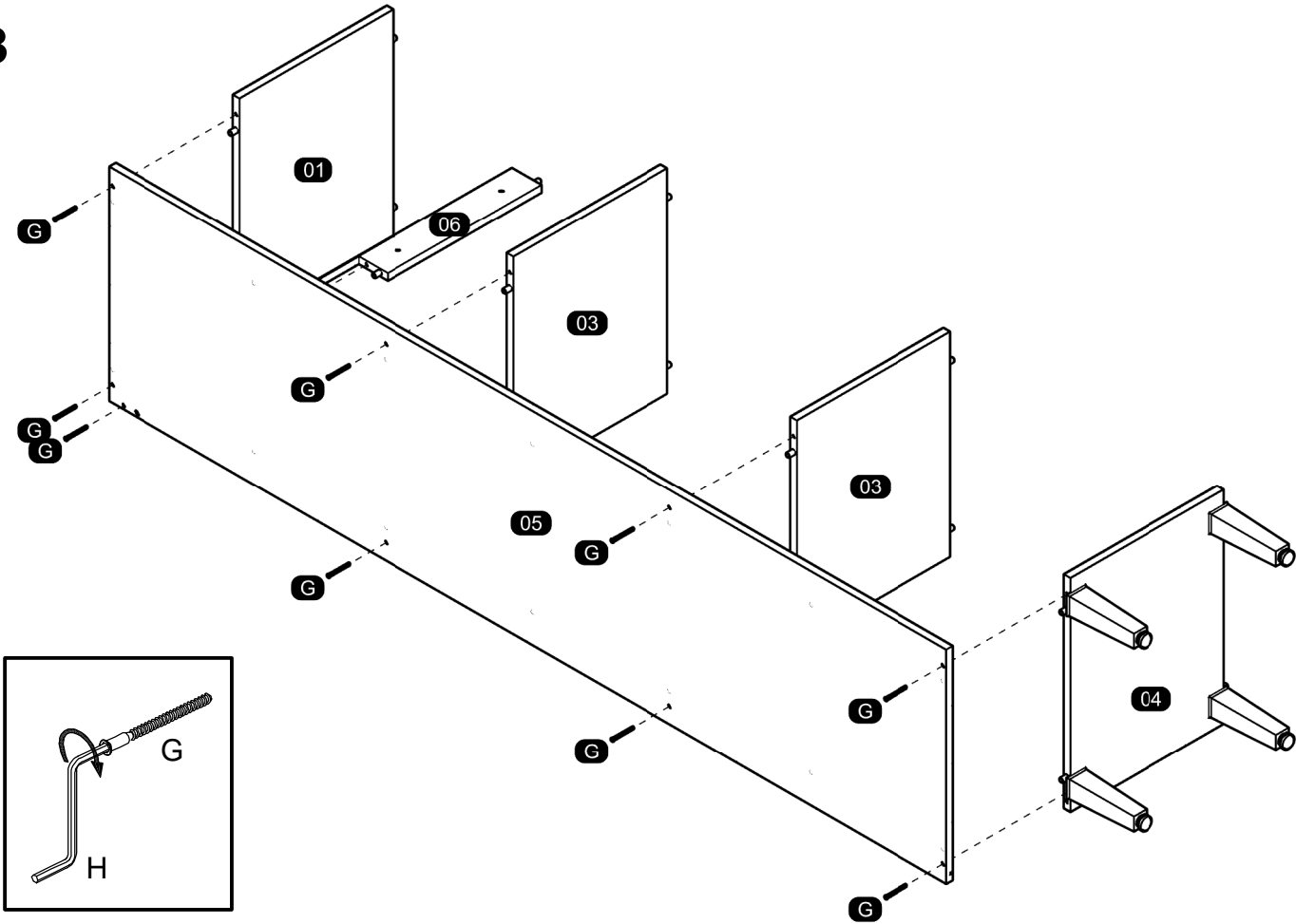

09

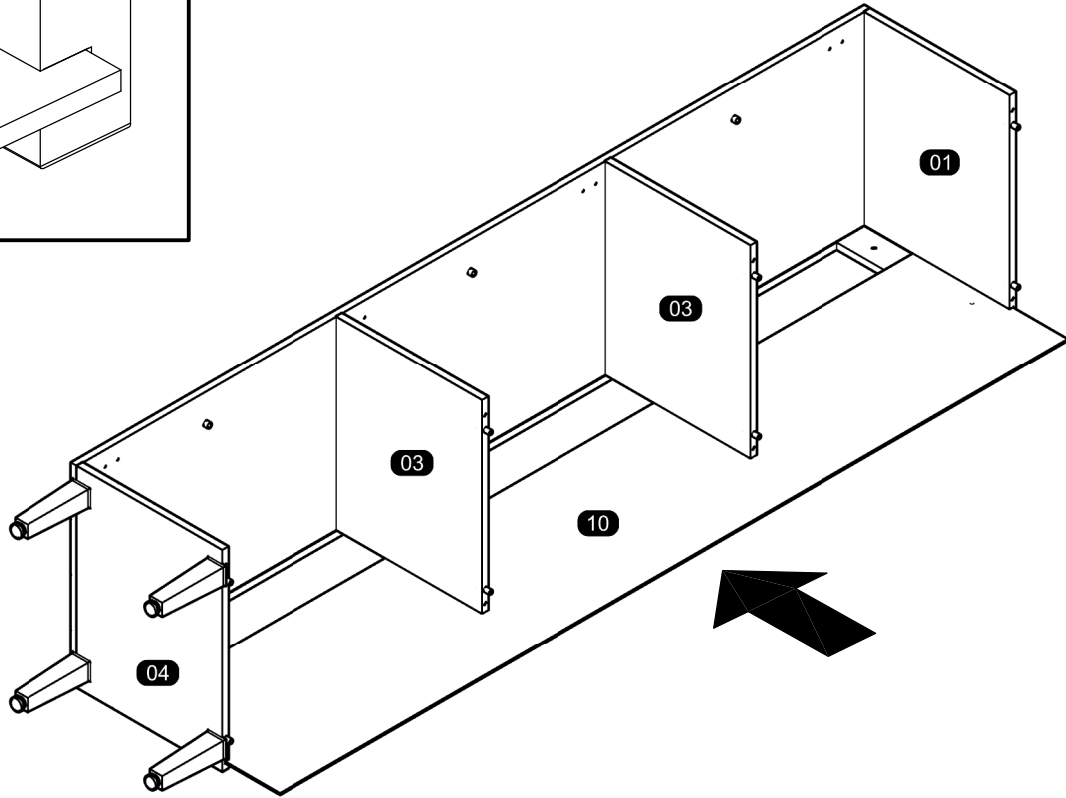
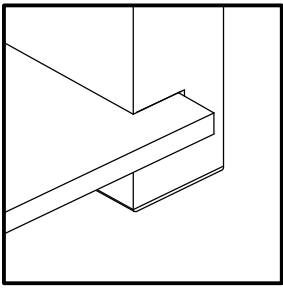

10

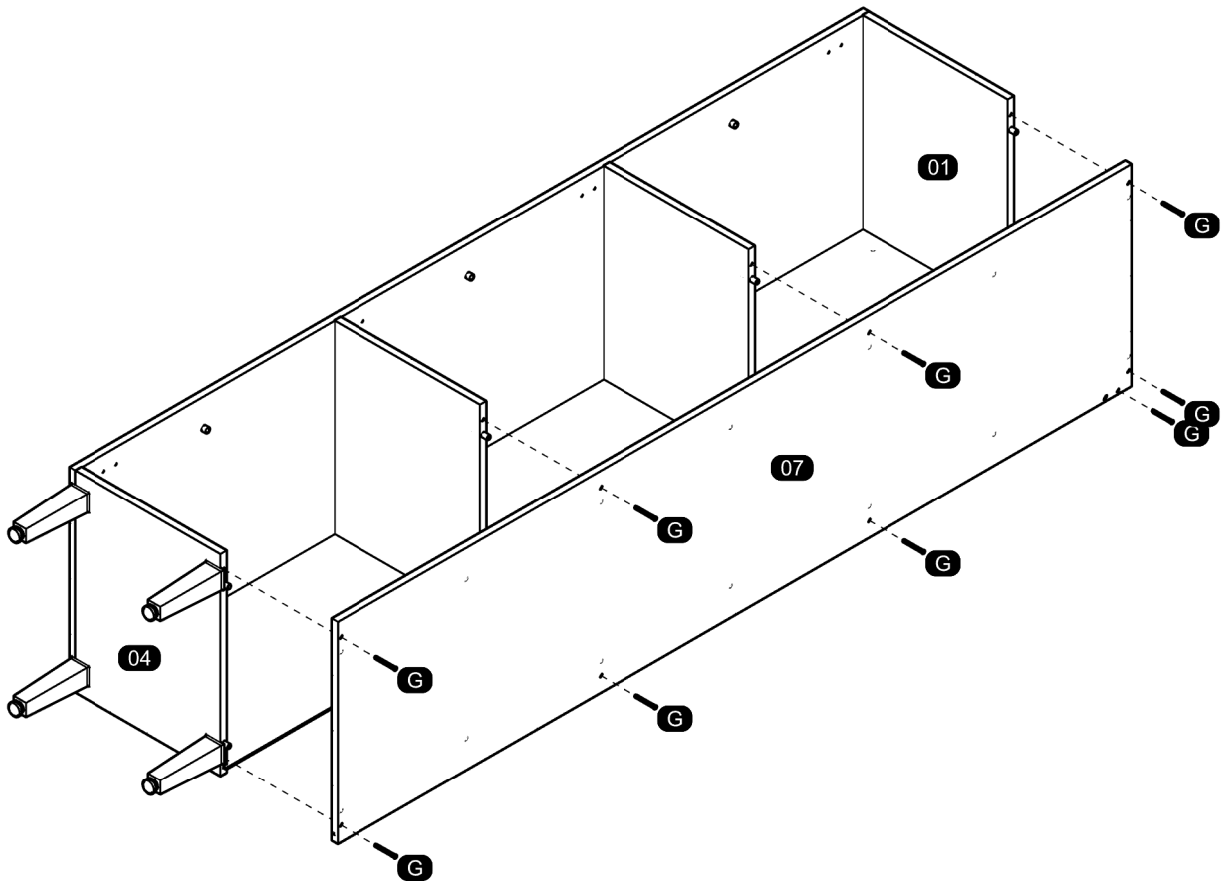

11

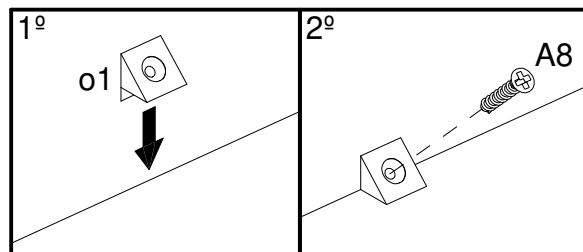
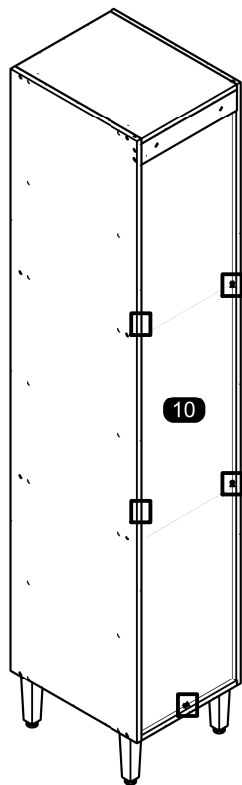

12

TO AVOID ANY INJURY THE FURNITURE MUST BE FIXED ON THE WALL. THANKS.
PARA EVITAR QUALQUER ACIDENTE, É OBRIGATÓRIO FIXAR O MÓVEL NA PAREDE. OBRIGADO!
PARA EVITAR CUALQUIER ACCIDENTE ES OBLIGATORIO ANCLAR EL MUEBLE EN LA PARED. GRACIAS.

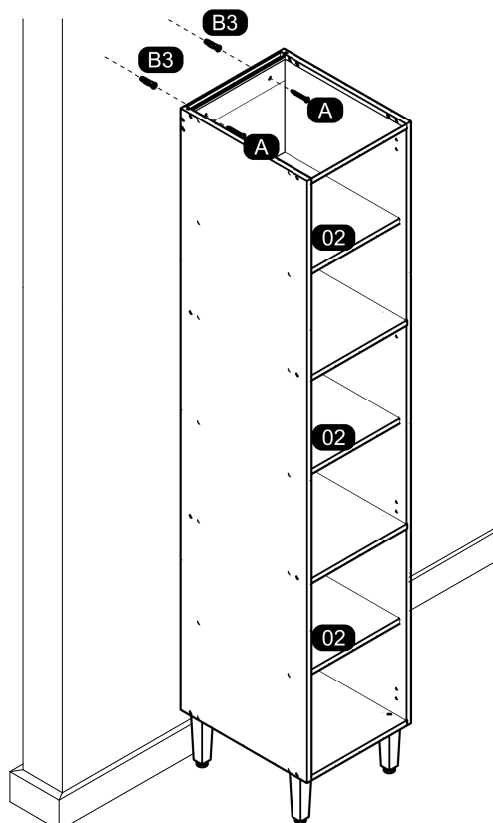

DOOR OPENING TO THE RIGHT
ABERTURA DA PORTA PARA DIREITA / APERTURA DE LA PUERTA A LA DERECHA

13

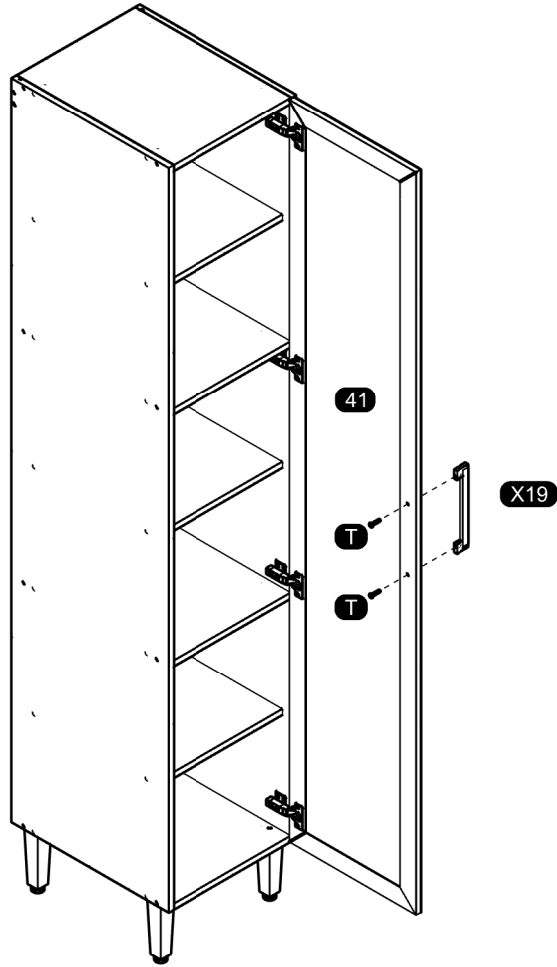
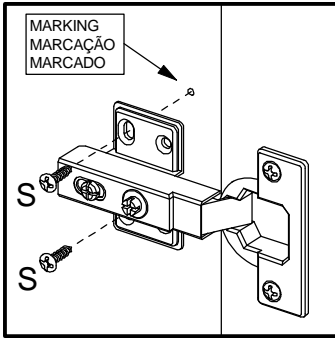

14

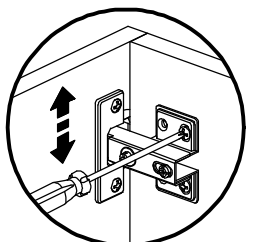
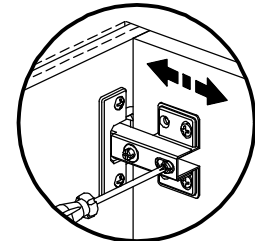
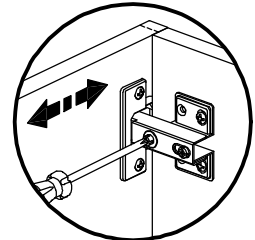
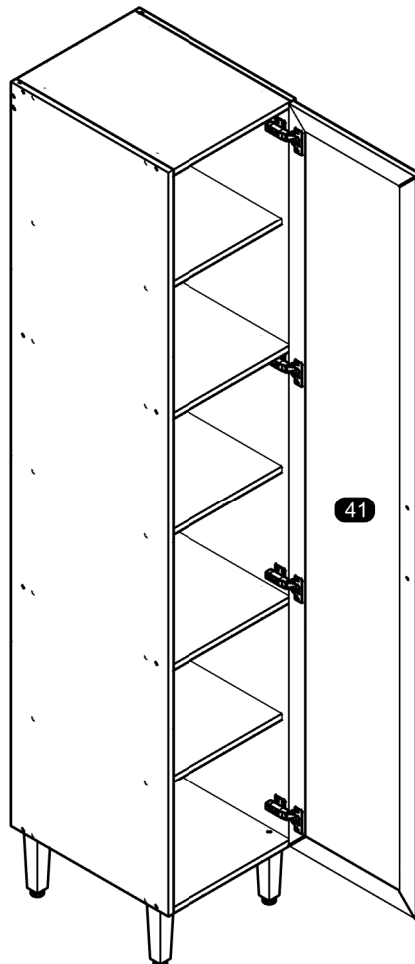
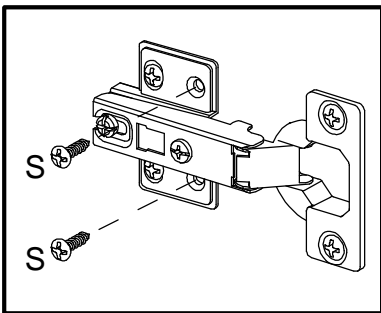

DOOR OPENING TO THE LEFT
ABERTURA DA PORTA PARA ESQUERDA / APERTURA DE LA PUERTA A LA IZQUIERDA

15

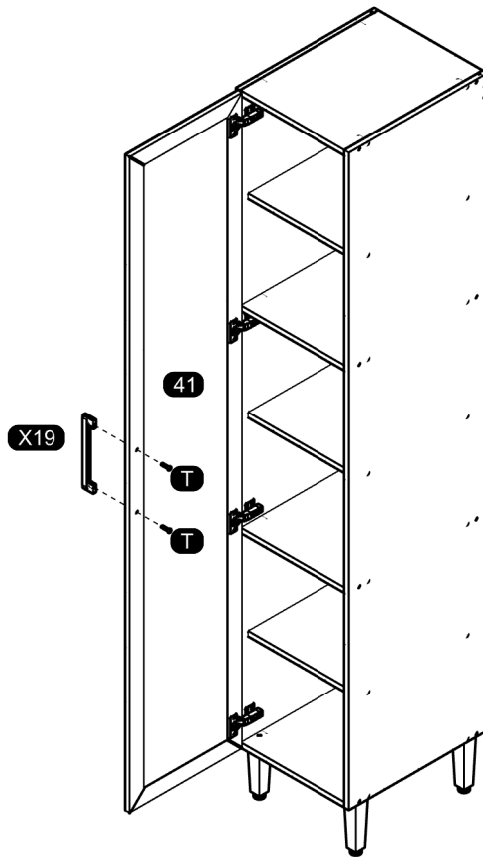
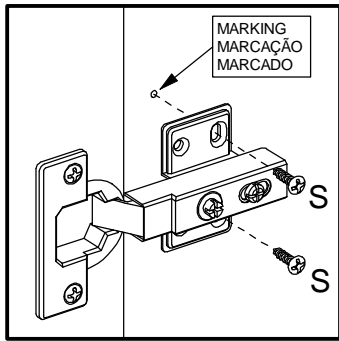

16

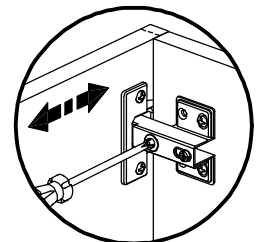
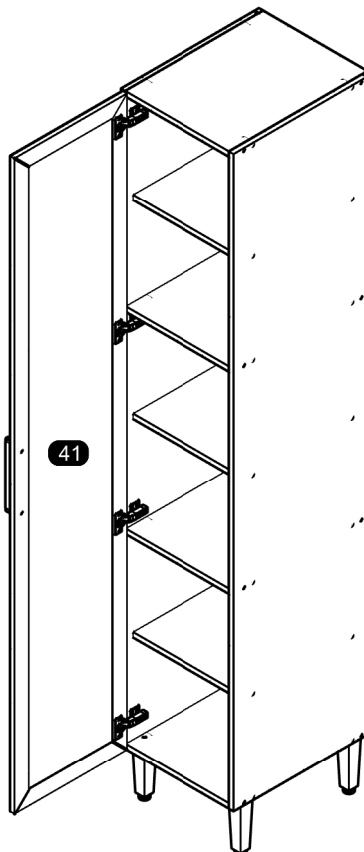
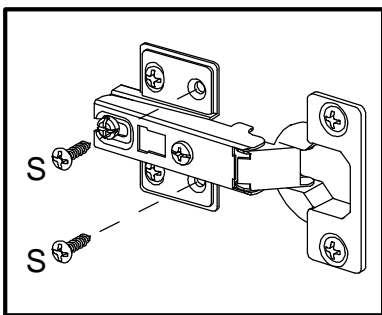

Horizontal Adjustment
Regulagem Horizontal
Ajuste Horizontal

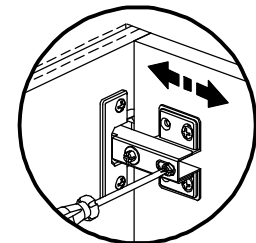

Depth Adjustment
Regulagem Profundidade
Ajuste Profundidad

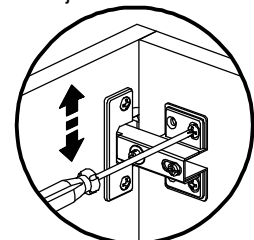

Vertical Adjustment
Regulagem Vertical
Ajuste Vertical

ASSEMBLY INSTRUCTIONS MANUAL DE MONTAGEM / INSTRUCCIONES DE ARMADO

CANELONE BASE CABINET 2 DOORS 3 DRAWERS 47 1/4"

BALCÃO 2 PORTAS 3 GAVETAS 1200MM CANELONE

GABINETE 2 PUERTAS 3 CAJONES 1200MM CANELONE

Reference
Referência
Referencia

220367

Revised
Revisão
Revisión

00



ENGLISH
PORTUGUÊS
ESPAÑOL

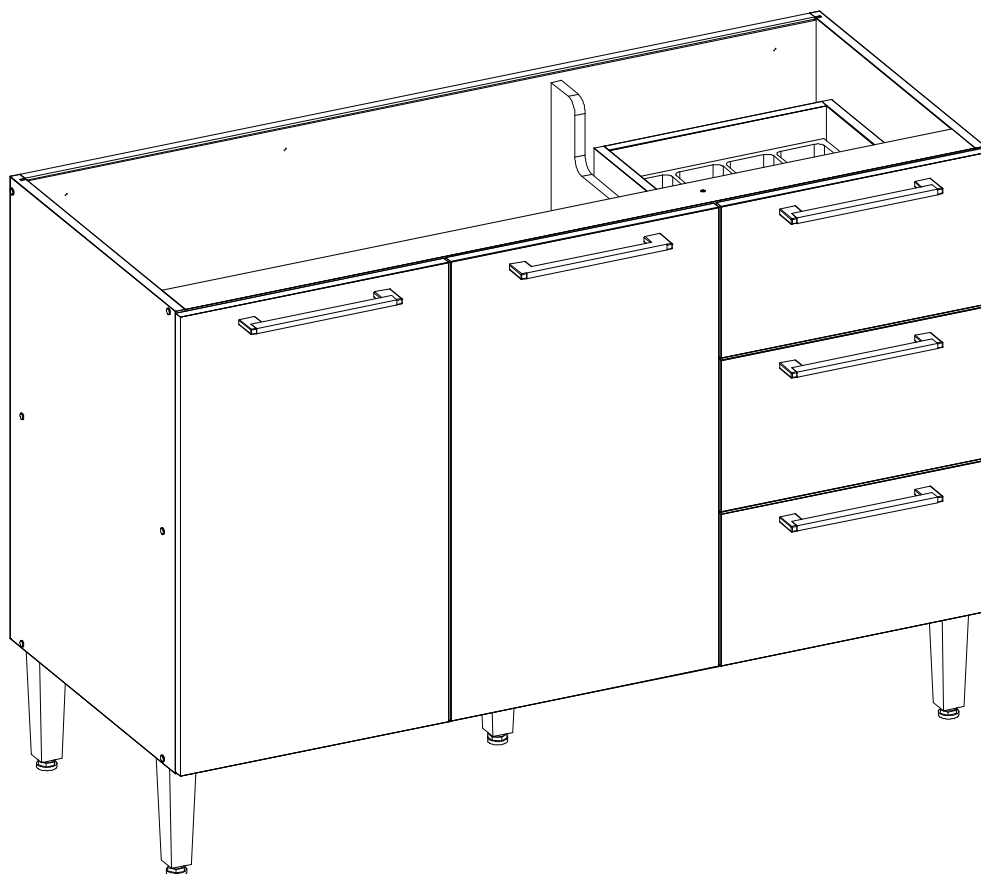

MAXIMUM RECOMMENDED WEIGHT
BEING THIS EVENLY DISTRIBUTED.

PESO MÁXIMO RECOMENDADO SENDO
ESTE DISTRIBUÍDO UNIFORMEMENTE.

PESO MÁXIMO RECOMENDADO SIENDO
ESTE UNIFORMEMENTE DISTRIBUIDO.

| | LB | KG |
|---|----|----|
| – | | |
| D | 11 | 5 |
| F | 22 | 10 |

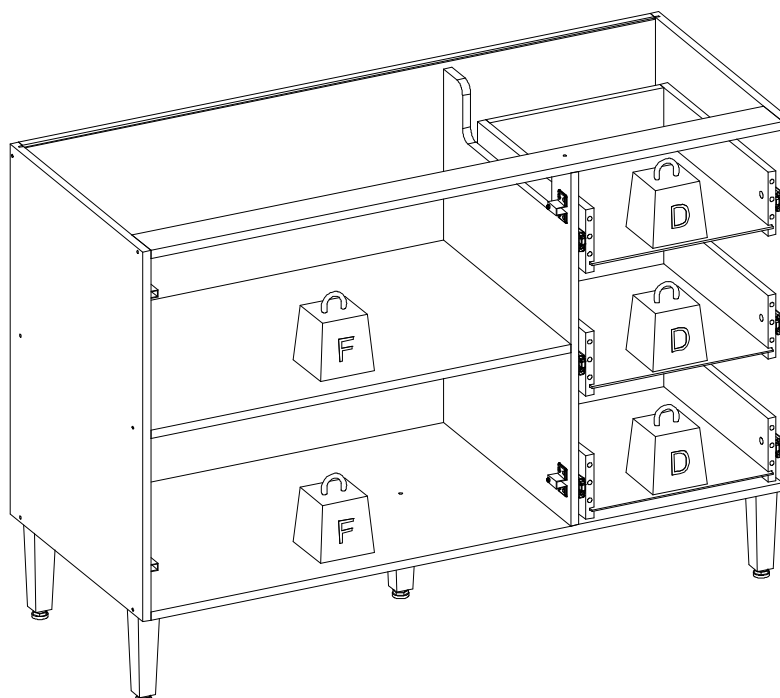

| Nº | Measures_Inches | Medidas_cm | Qty./Qtd. |
|----|-----------------------|--------------------|-----------|
| 01 | 46 x 2 3/4 x 5/8 | 116.9 x 7.0 x 1.5 | 1 |
| 02 | 46 x 2 3/8 x 5/8 | 116.9 x 6.0 x 1.5 | 1 |
| 03 | 30 5/8 x 18 1/2 x 5/8 | 77.7 x 47.1 x 1.5 | 1 |
| 04 | 26 3/8 x 19 1/4 x 5/8 | 67.0 x 49.0 x 1.5 | 1 |
| 05 | 46 x 19 1/4 x 5/8 | 116.9 x 49.0 x 1.5 | 1 |
| 06 | 25 1/4 x 18 1/2 x 5/8 | 64.0 x 47.1 x 1.5 | 1 |
| 07 | 26 3/8 x 19 1/4 x 5/8 | 67.0 x 49.0 x 1.5 | 1 |
| 08 | 12 5/8 x 4 1/2 x 5/8 | 32.2 x 11.5 x 1.5 | 3 |
| 09 | 15 3/4 x 13 1/4 x 1/8 | 39.9 x 33.6 x 0.3 | 3 |
| 10 | 46 5/8 x 13 x 1/8 | 118.3 x 32.9 x 0.3 | 2 |
| 11 | 26 1/4 x 15 5/8 x 5/8 | 66.6 x 39.7 x 1.5 | 1 |
| 12 | 26 1/4 x 15 5/8 x 5/8 | 66.6 x 39.7 x 1.5 | 1 |
| 13 | 8 5/8 x 15 5/8 x 5/8 | 22.0 x 39.7 x 1.5 | 3 |
| 88 | 15 3/4 x 4 1/2 x 5/8 | 40.0 x 11.5 x 1.5 | 3 |
| 89 | 15 3/4 x 4 1/2 x 5/8 | 40.0 x 11.5 x 1.5 | 3 |

PARTS IDENTIFICATION IDENTIFICAÇÃO DAS PEÇAS / IDENTIFICACIÓN DE LAS PIEZAS

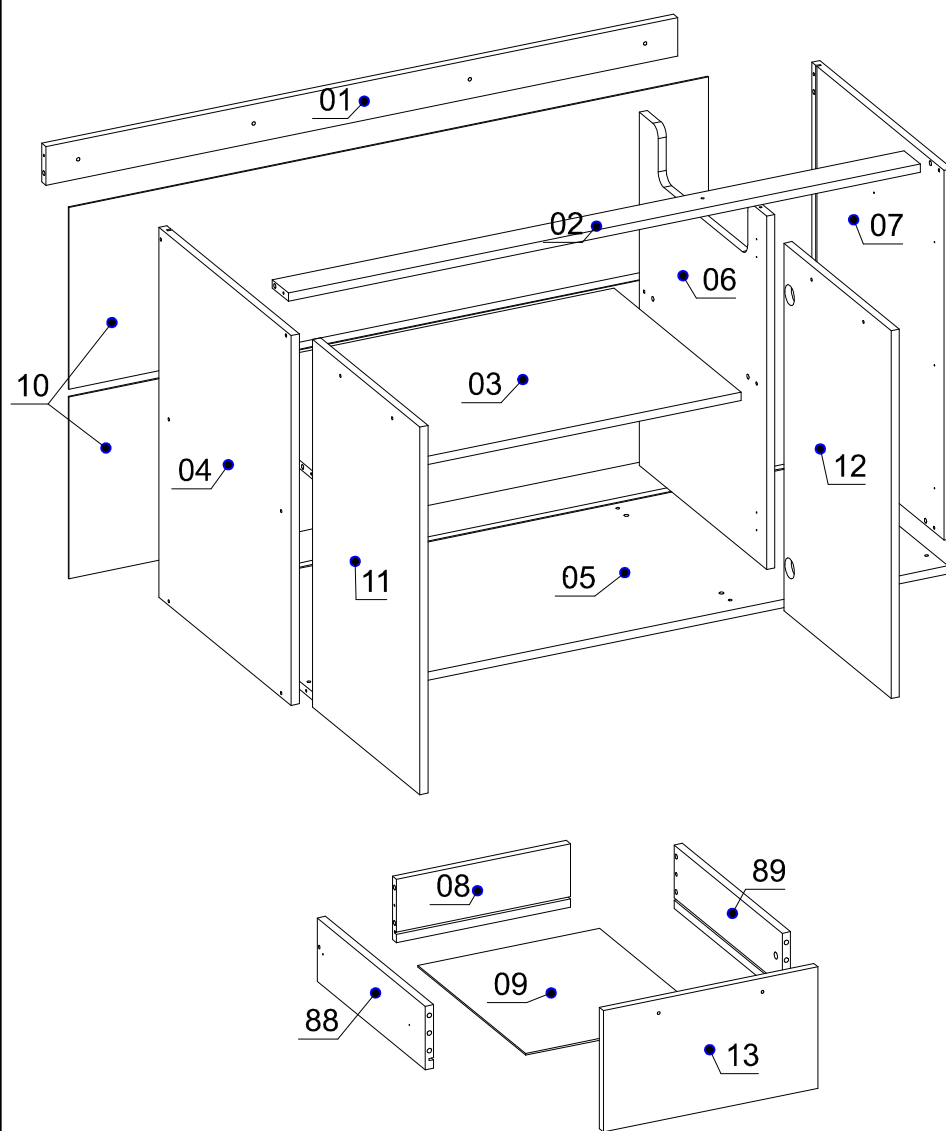

YOU WILL NEED / VOCÊ VAI PRECISAR DE / USTED NECESITARÁ

Tools not supplied / Ferramentas não fornecidas / Herramientas no incluidas

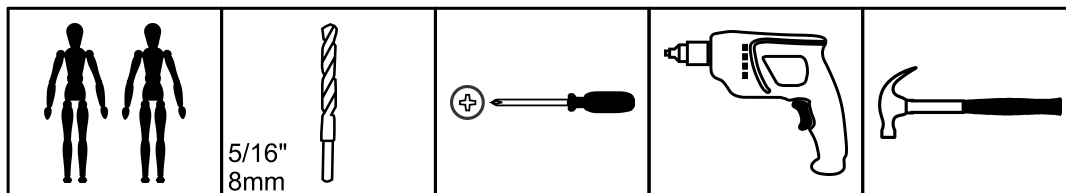

2 People
2 Pessoas
2 Personas

5/16"
8mm
Drill bit
Broca
Taladro

Screwdriver Phillips
Chave Phillips
Destornillador cruz

Drill machine
Furadeira
Taladro

Hammer
Martelo
Martillo











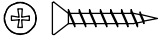
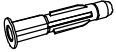
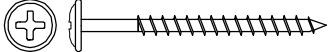

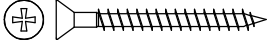
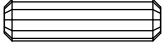
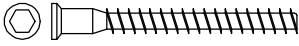

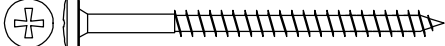
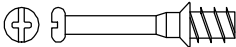

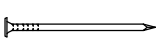

The separation of the accessories before you start the assembly will facilitate the same. In case of doubt on the size of the screws and bolts, use the ruler to bottom of page 3.

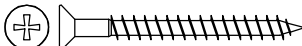
A separação dos acessórios antes de iniciar a montagem facilitará a mesma. Em caso de dúvida no tamanho dos parafusos e cavilhas, utilize a régua ao final da página 3.

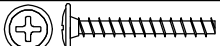
La separación de los accesorios antes de comenzar el armado facilitará el mismo. En caso de duda sobre el tamaño de los tornillos y taquetes, utilice la regla al pie de página 3.

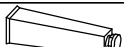
IDENTIFICATION OF ACCESSORIES IDENTIFICAÇÃO DOS ACESSÓRIOS/ IDENTIFICACIÓN DE ACCESORIOS

| | | | | |
|-----|---|--|-----------|----|
| A1 |  | Glue / Cola / Pegamento | 13 g | 1 |
| A8 |  | Flat head screw / Parafuso chato / Tornillo de cabeza plana | 3,5x20 mm | 6 |
| B3 |  | Bushing / Bucha expansiva / Tapón | 8x50 mm | 3 |
| C |  | Flanged head screw / Parafuso flangeado / Tornillo de cabeza flangeada | 4,5x45 mm | 5 |
| C1 |  | Metal claw / Garra de metal / Garra metal | - | 5 |
| D |  | Flat head screw / Parafuso chato / Tornillo de cabeza plana | 4,0x40 mm | 1 |
| E |  | Wooden dowel / Cavilha / Taquete | 8x30 mm | 38 |
| G |  | Structural screw / Parafuso estrutural / Tornillo estructural | 5,0x50 mm | 13 |
| H |  | Allen key / Chave allen / Llave allen | 3 mm | 1 |
| I |  | Structural screw cover/Tampa parafuso estrutural/Tapa tornillo estructural | - | 10 |
| i4 |  | Pan head screw / Parafuso panela / Tornillo de pan | 5,0x70 mm | 3 |
| J |  | Simple minifix screw / Haste minifix simples / Tornillo minifix simple | - | 6 |
| K11 |  | Silicone stop / Batente de silicone / Tope de silicona | 8 mm | 5 |
| L |  | Drum lock / Tambor minifix / Tambor minifix | 12 mm | 6 |
| M |  | Bore patch adhesive / Tapa furo adesivo / Tapones adhesivo | - | 6 |
| M17 |  | Metal hinge straight / Dobradiça reta / Bisagra recta | 35 mm | 2 |
| N |  | Nail / Prego / Clavo | 10x10 | 5 |
| N17 |  | Metal hinge straight / Dobradiça curva / Bisagra recta | 35 mm | 2 |
| O |  | Flat head screw / Parafuso chato / Tornillo de cabeza plana | 4,5x45 mm | 8 |
| o1 |  | Triangular support / Suporte triangular / Soporte triangular | - | 6 |
| S |  | Pan head screw / Parafuso panela / Tornillo de pan | 3,5x14 mm | 48 |
| T |  | Flanged head screw / Parafuso flangeado / Tornillo de cabeza flangeada | 3,5x25 mm | 10 |
| T7 |  | Cutlery divider / Divisor de Talheres / Divisor de cubiertos | 384x314mm | 1 |
| V3 |  | Telescopic slide / Corrediça telescópica / Corredera telescópica | 400 mm | 3 |
| X15 |  | Foot / Pé Cônico FP / Pie | 170 mm | 5 |
| X19 |  | Handle / Puxador Citrino / Tirador | 192 mm | 5 |
| Z |  | Plastic hole plugs / Tapa furo plástico / Tapones plásticos | 8 mm | 2 |

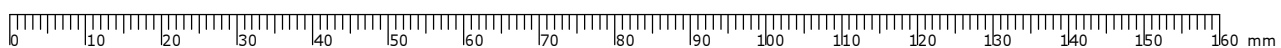

PRE-ASSEMBLE
PRÉ-MONTAGEM / PRE ARMADO

01

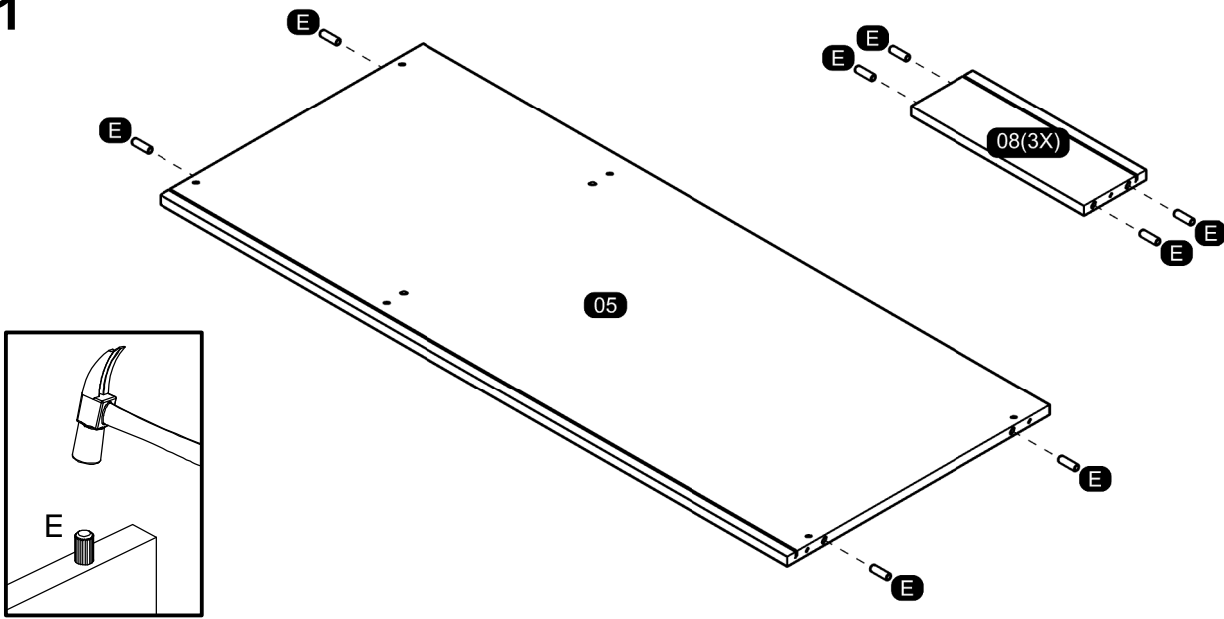

02

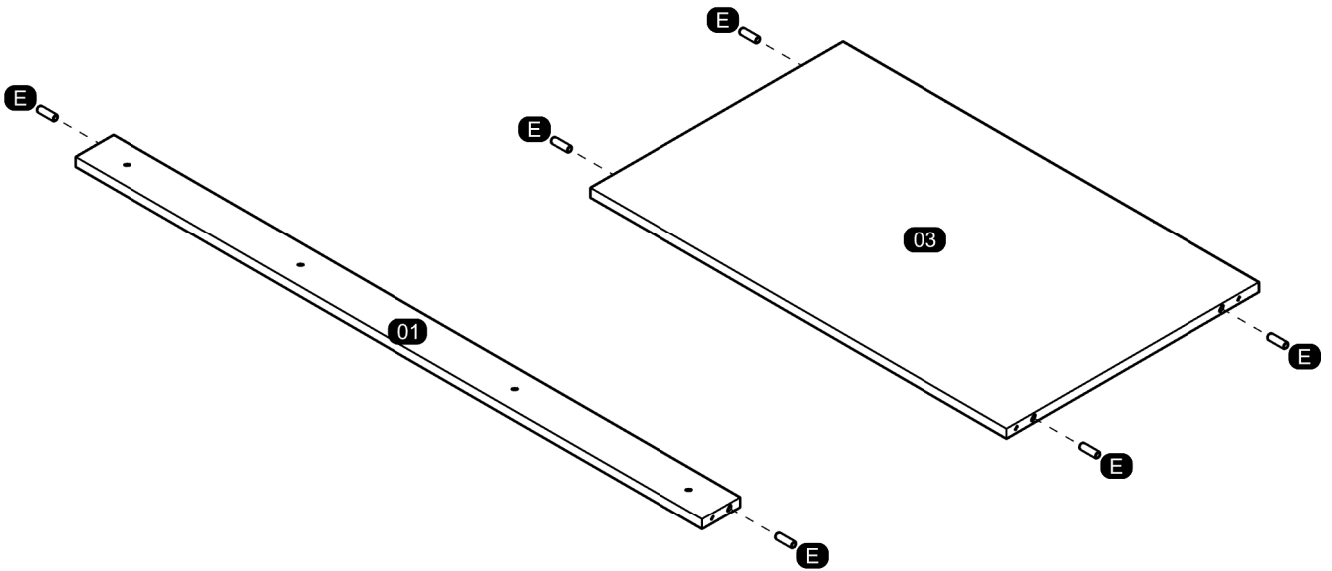

03

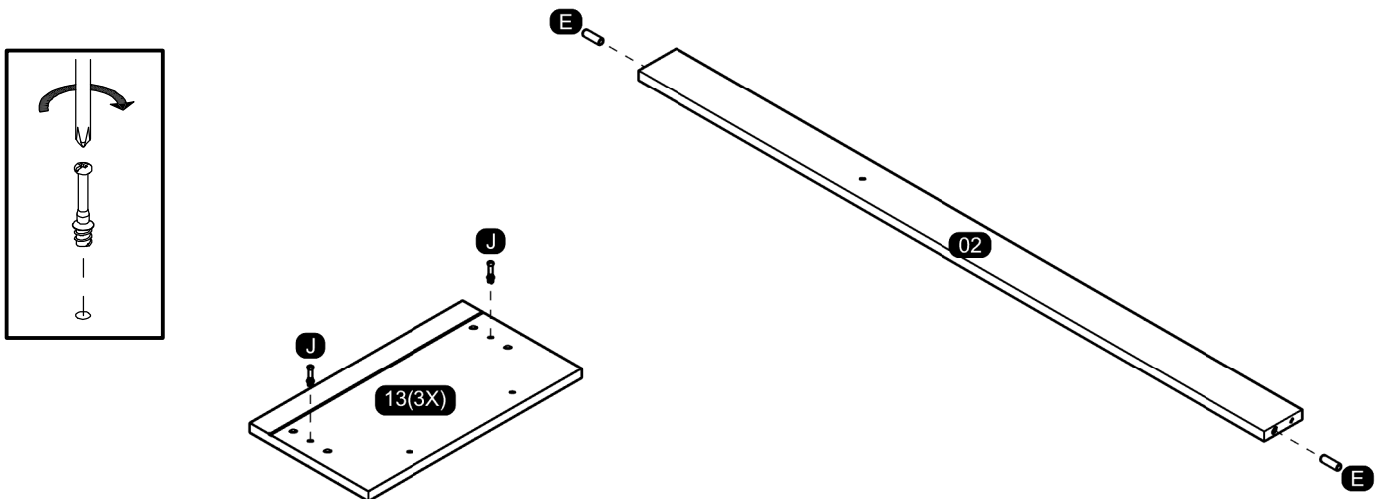

04

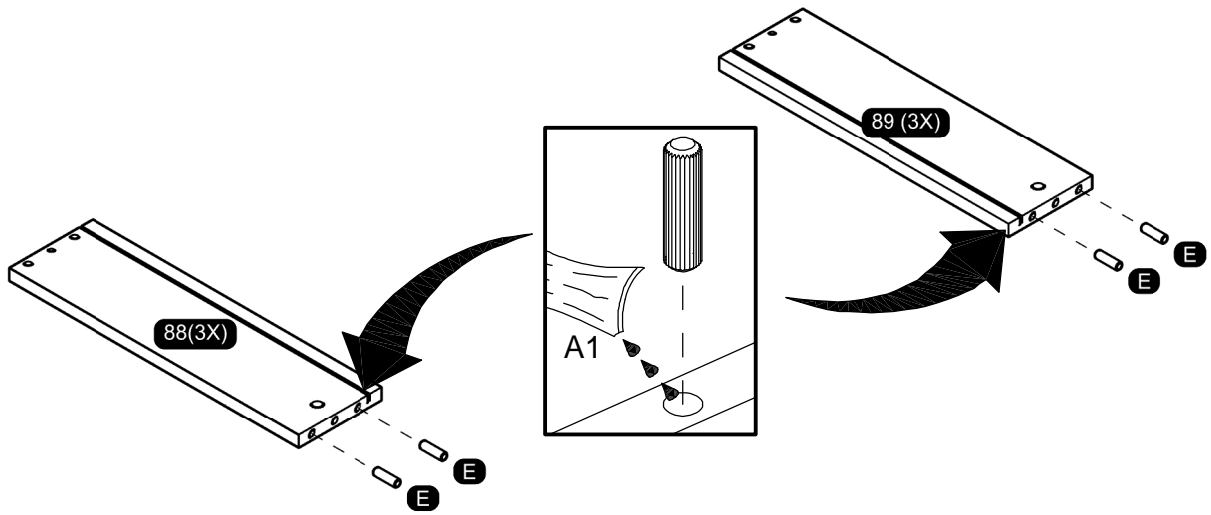

05

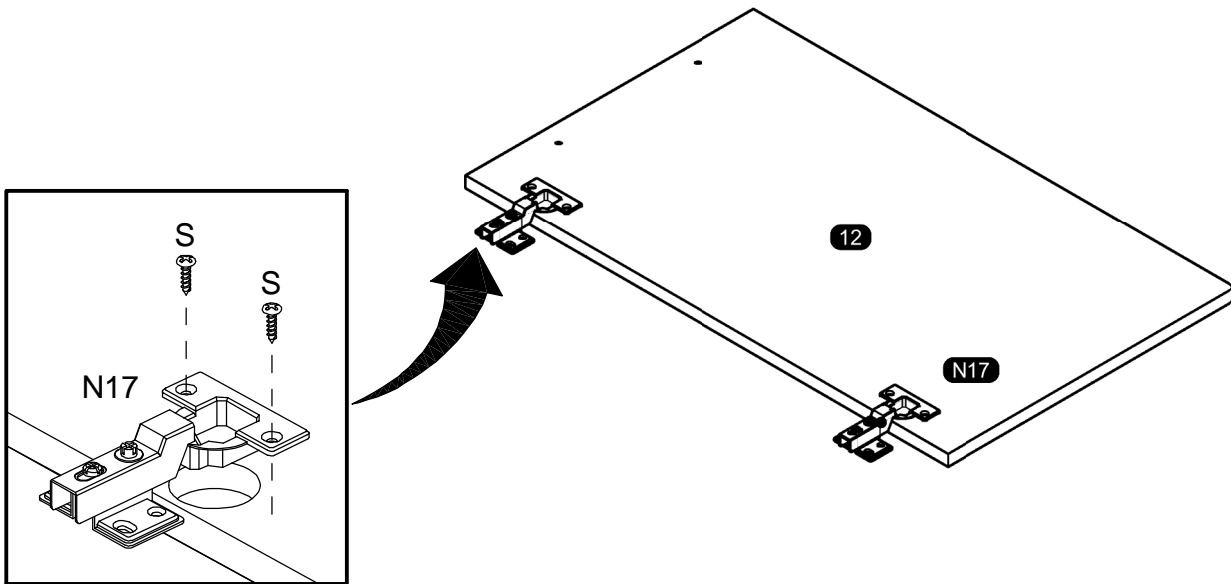

06

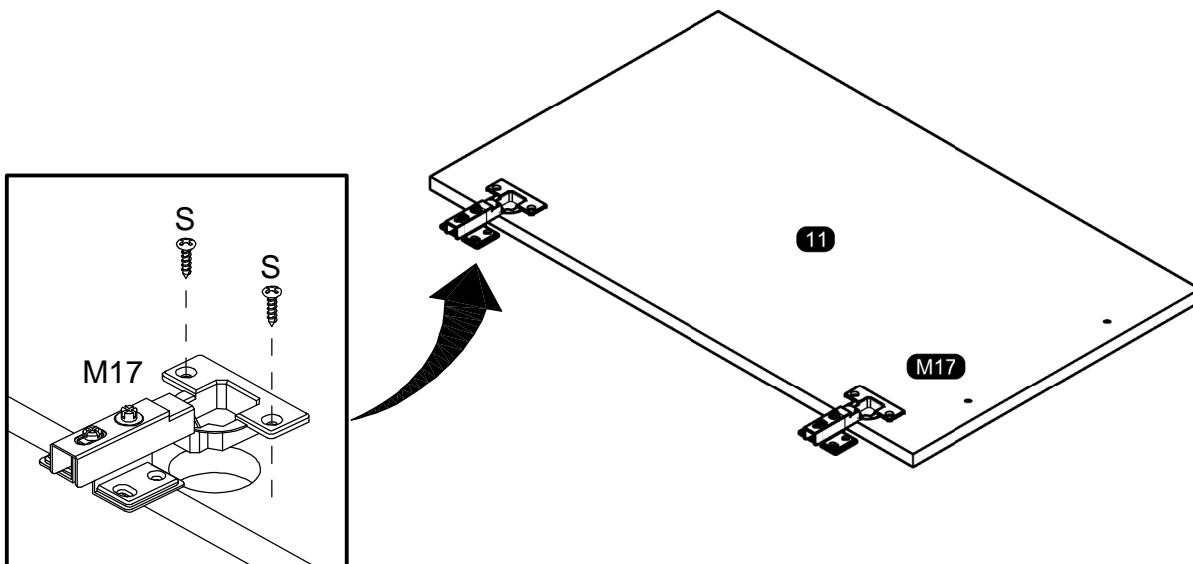

07

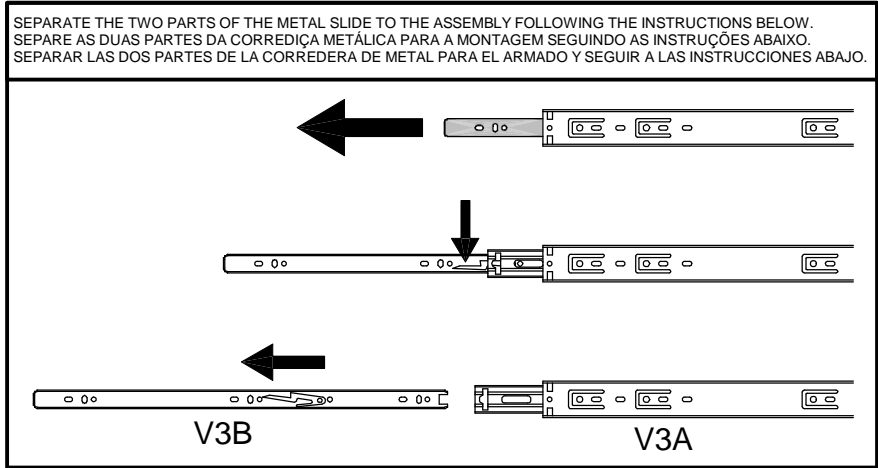

08

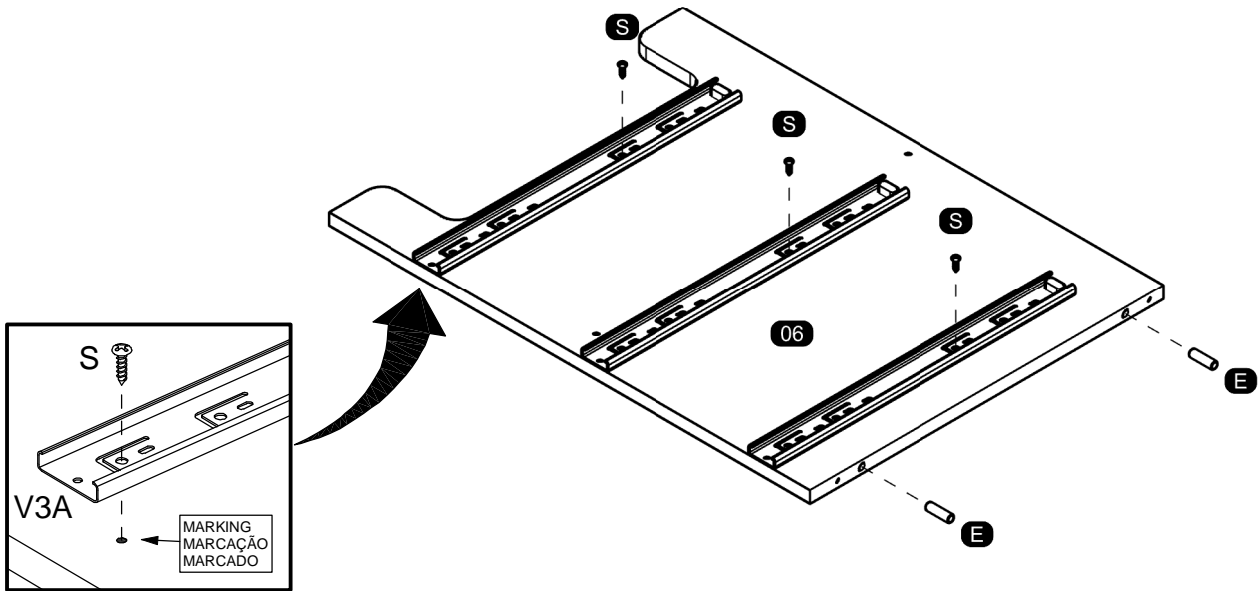

09

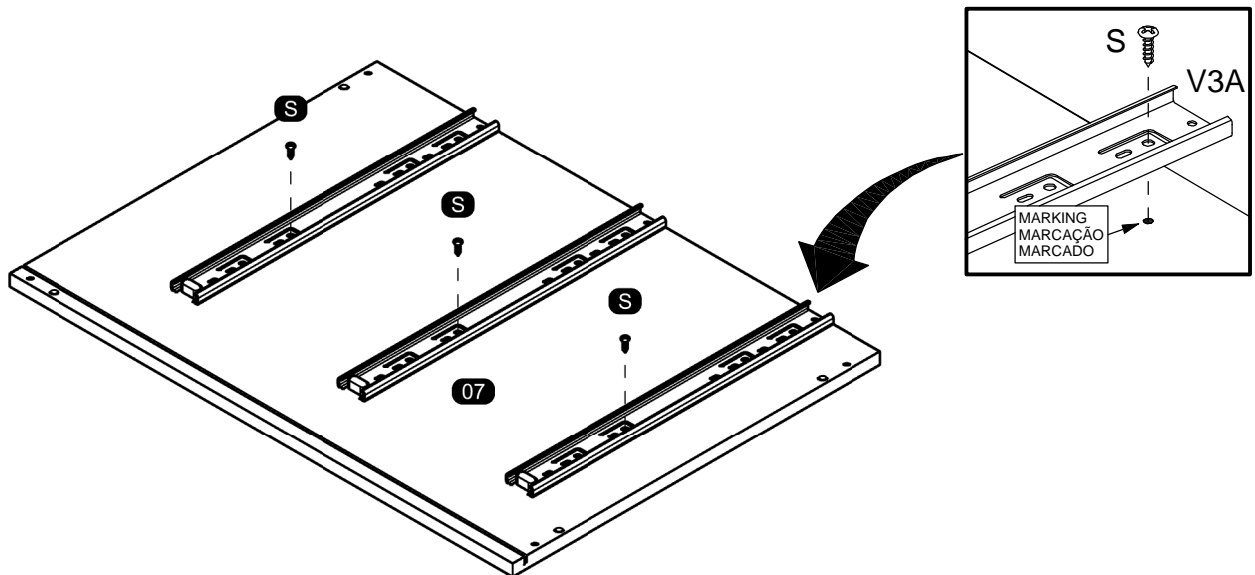

ASSEMBLY
MONTAGEM / ARMADO

10

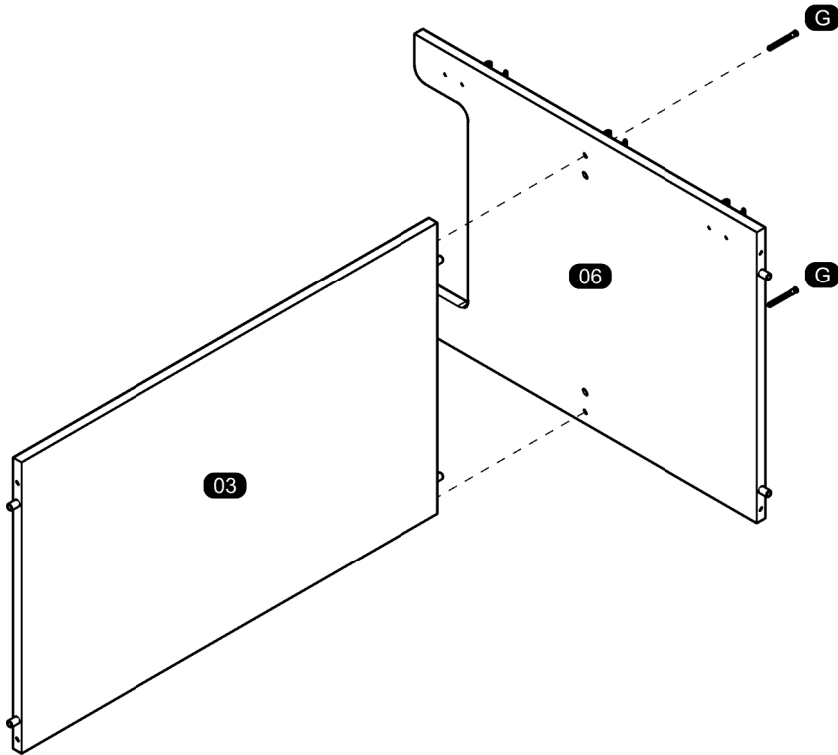
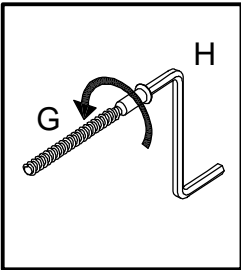

11

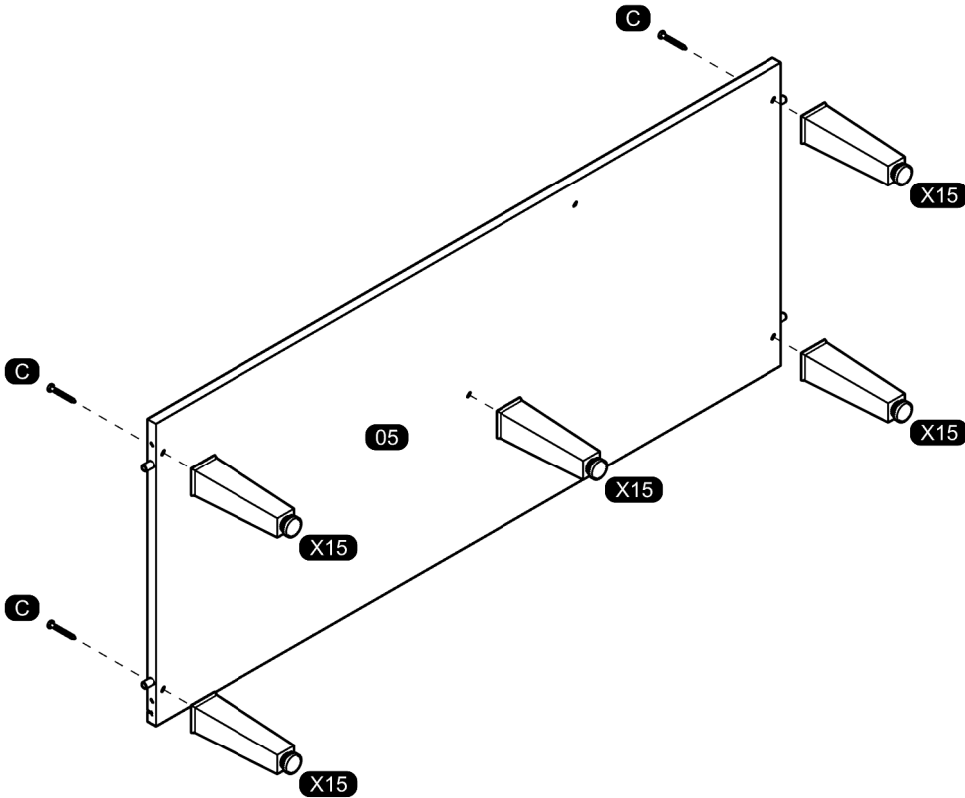

12

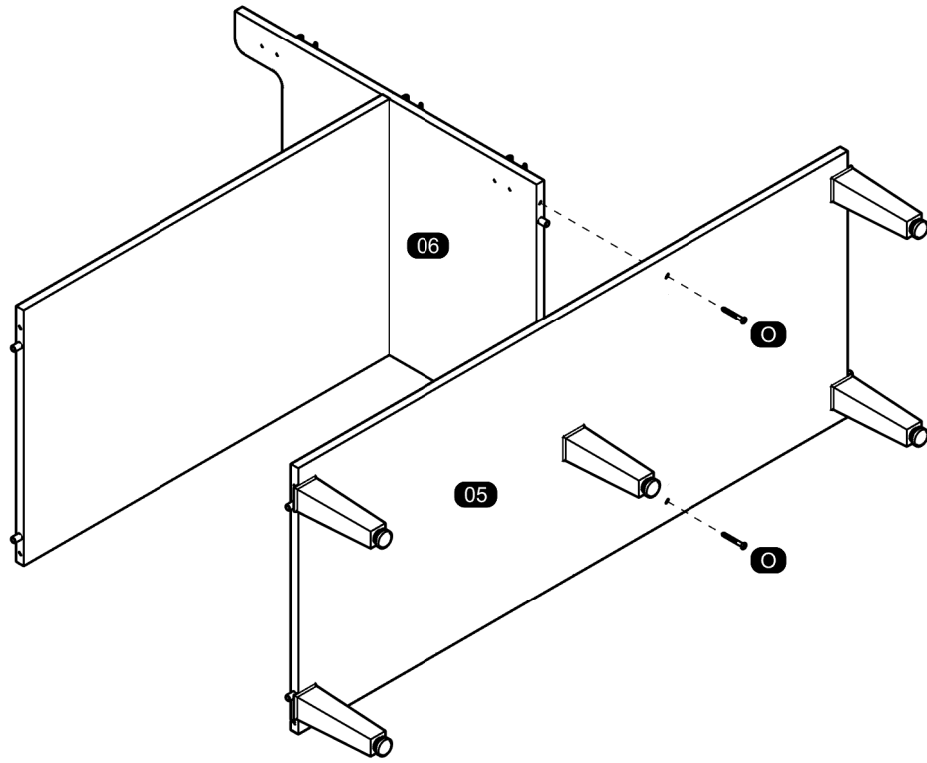

13

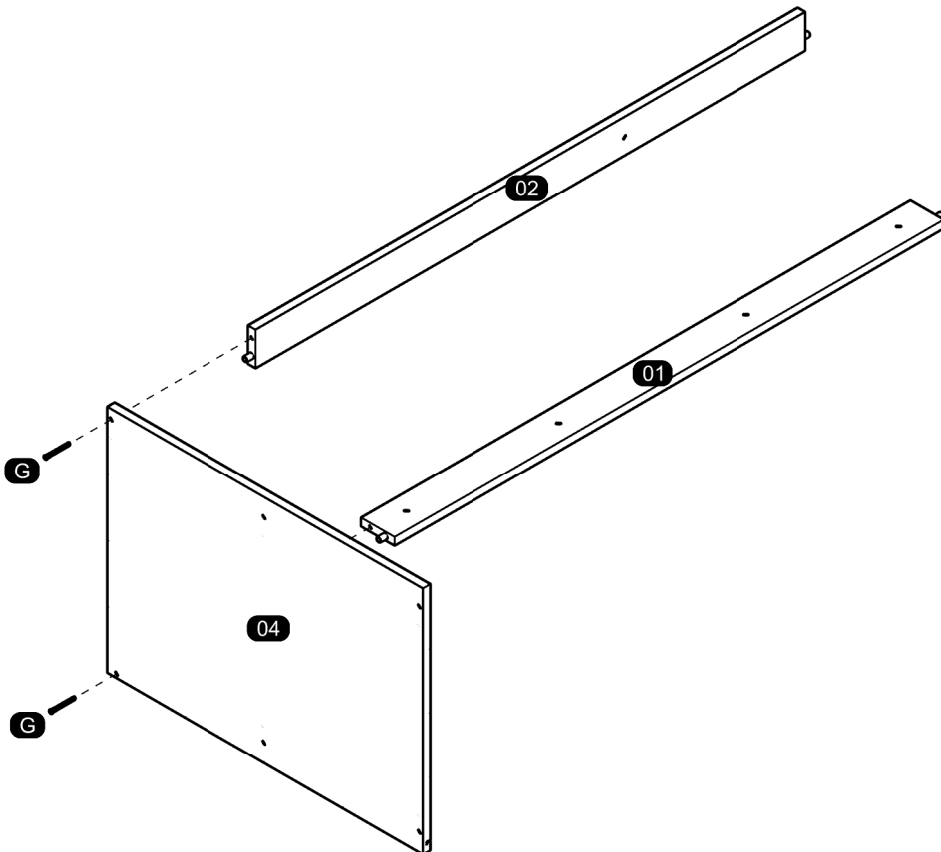

14

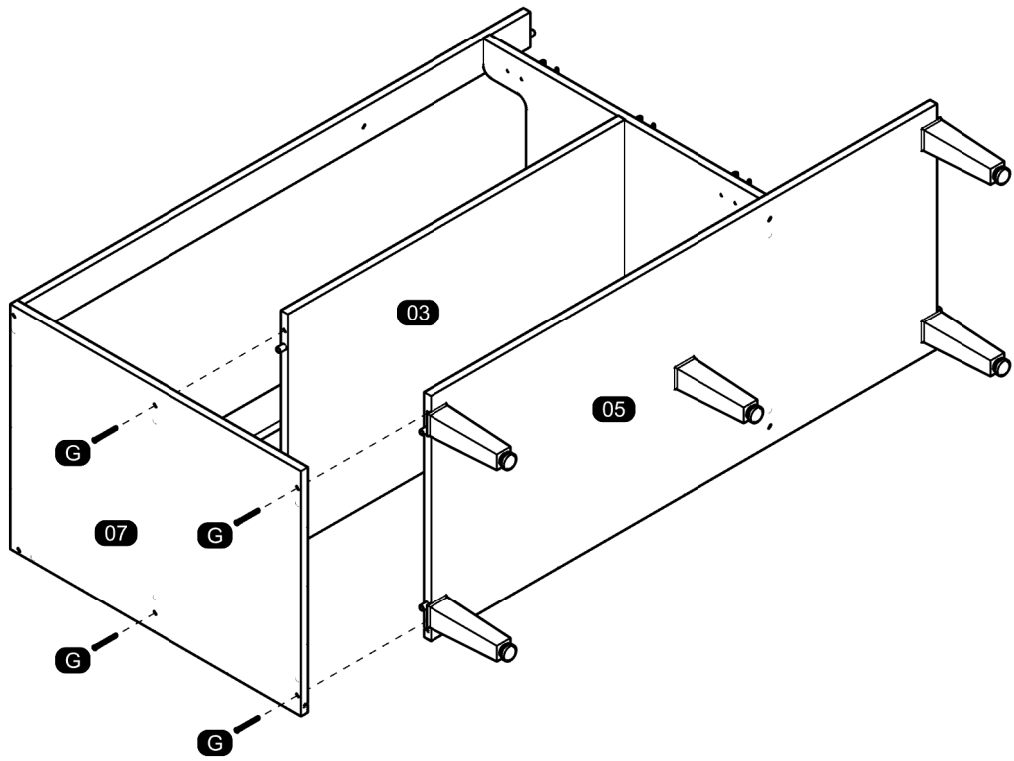

15

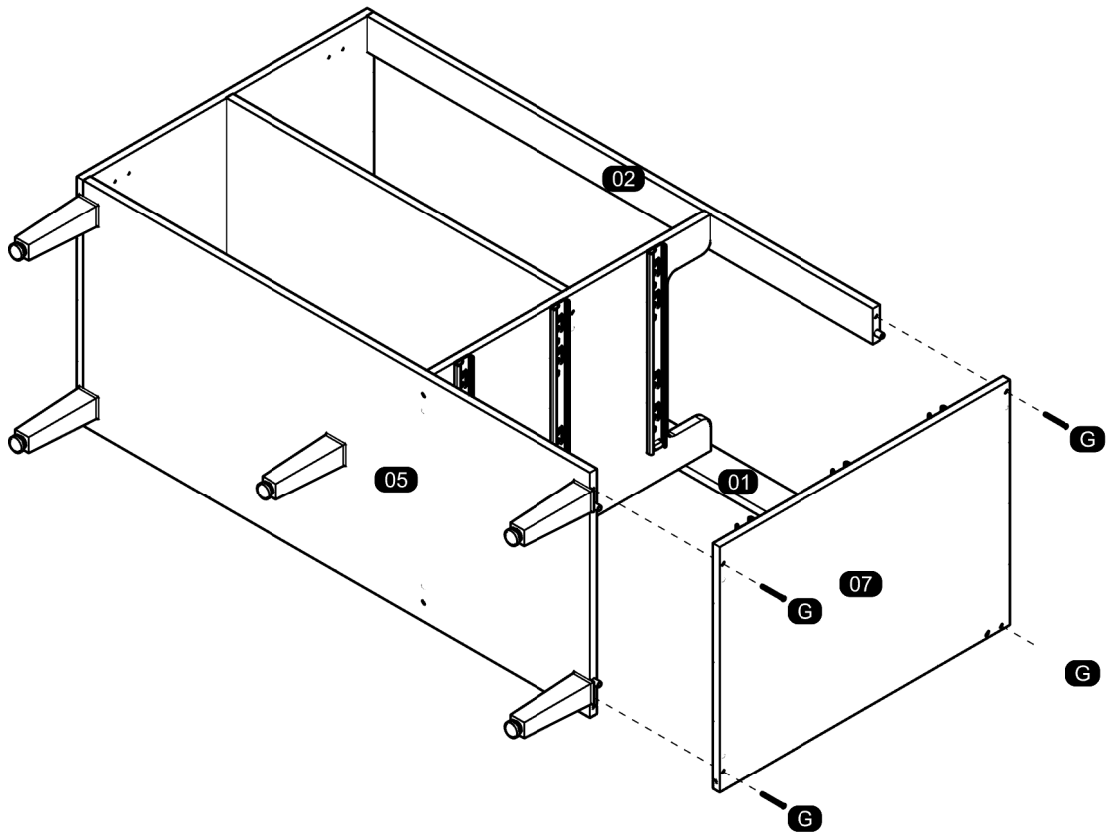

16

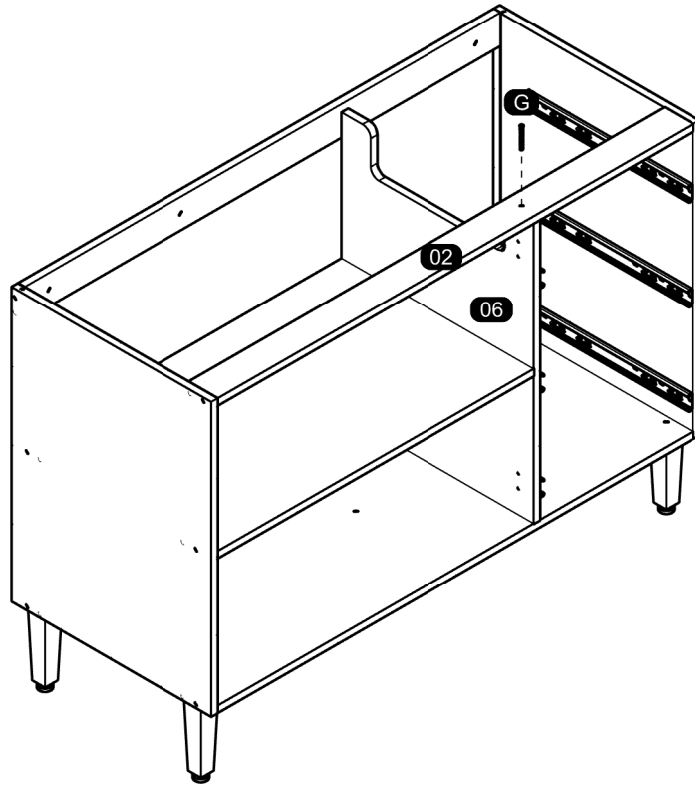

17

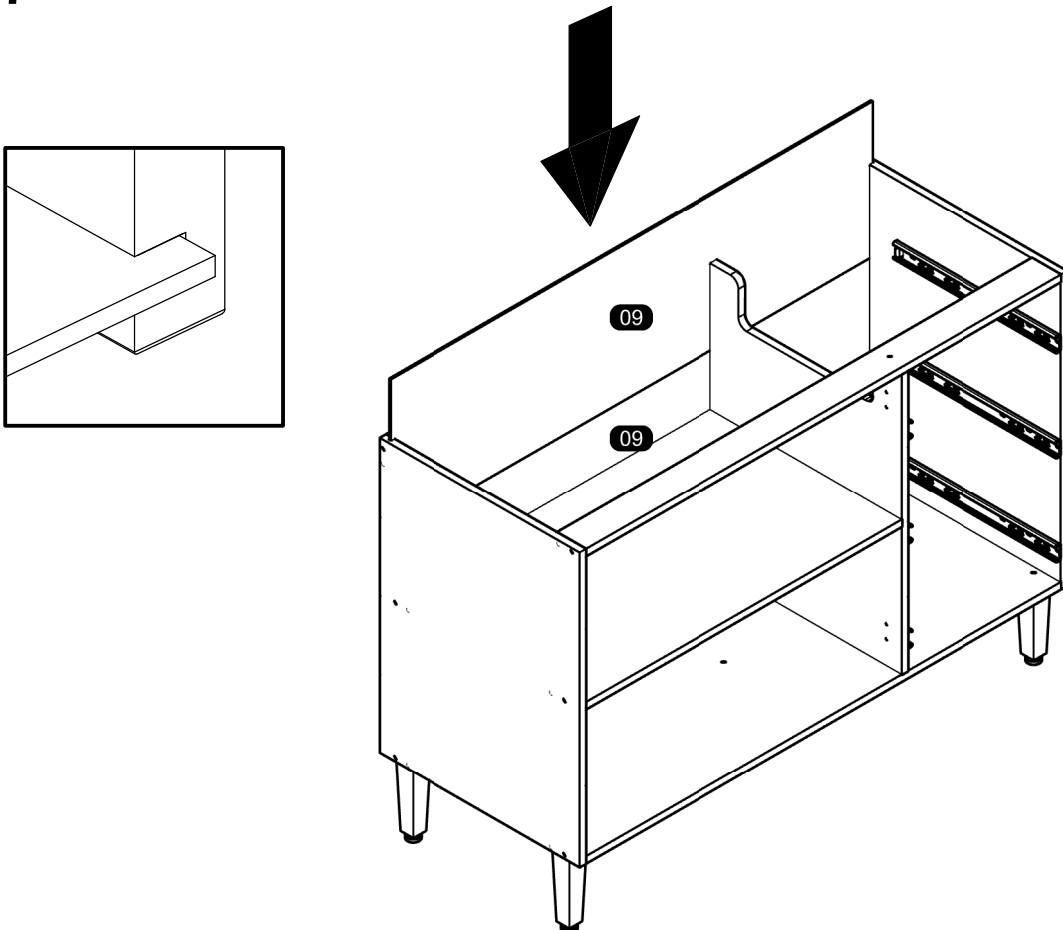

18

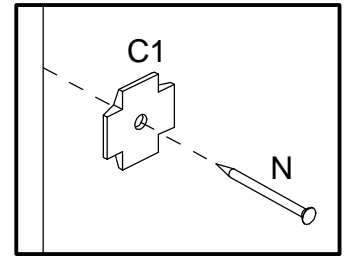
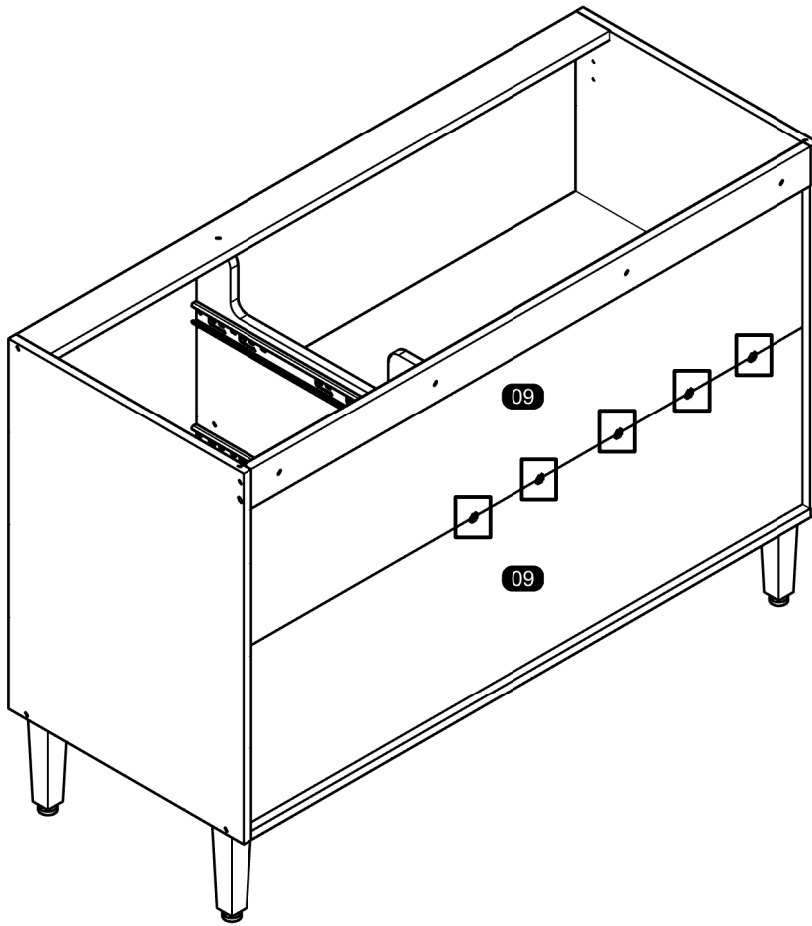

19

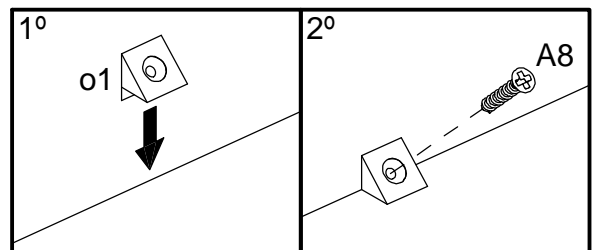
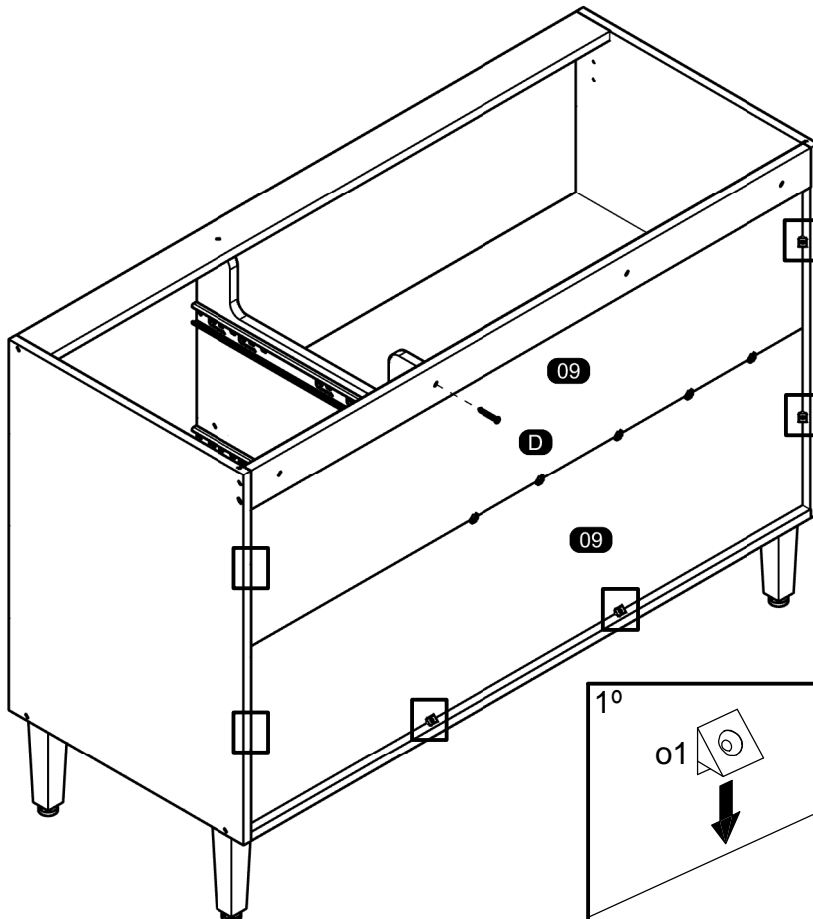

20

TO AVOID ANY INJURY THE FURNITURE MUST BE FIXED ON THE WALL. THANKS.
PARA EVITAR QUALQUER ACIDENTE, É OBRIGATÓRIO FIXAR O MÓVEL NA PAREDE. OBRIGADO!
PARA EVITAR CUALQUIER ACCIDENTE ES OBLIGATORIO ANCLAR EL MUEBLE EN LA PARED. GRACIAS.

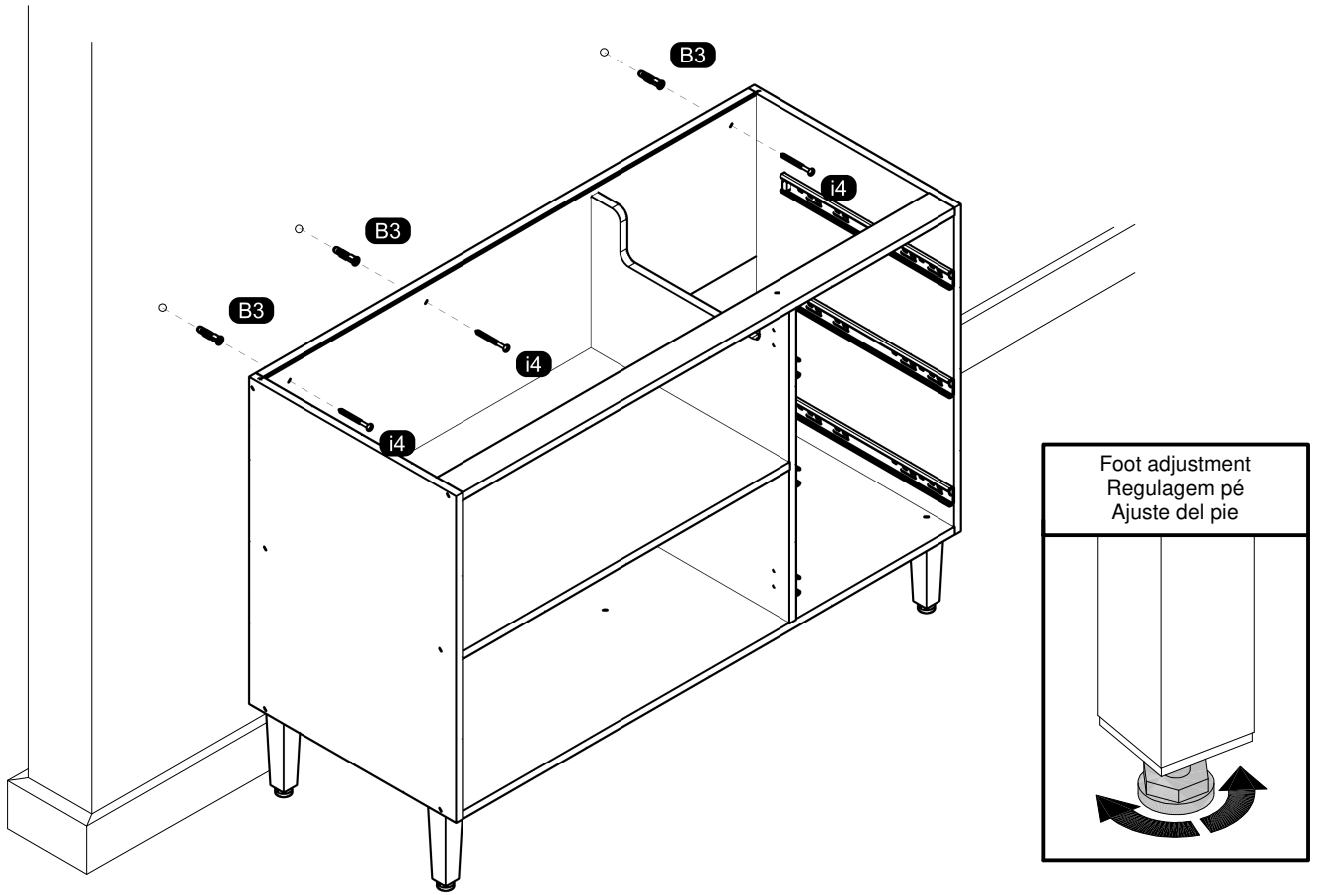

21

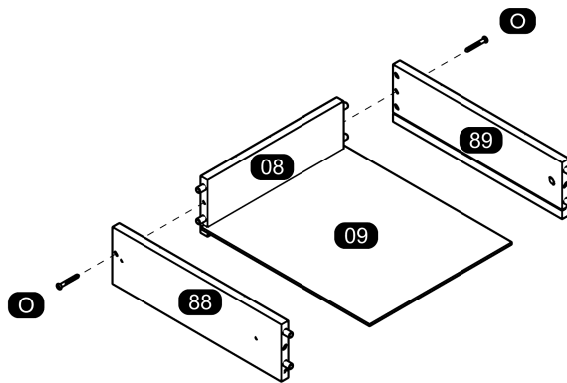

22

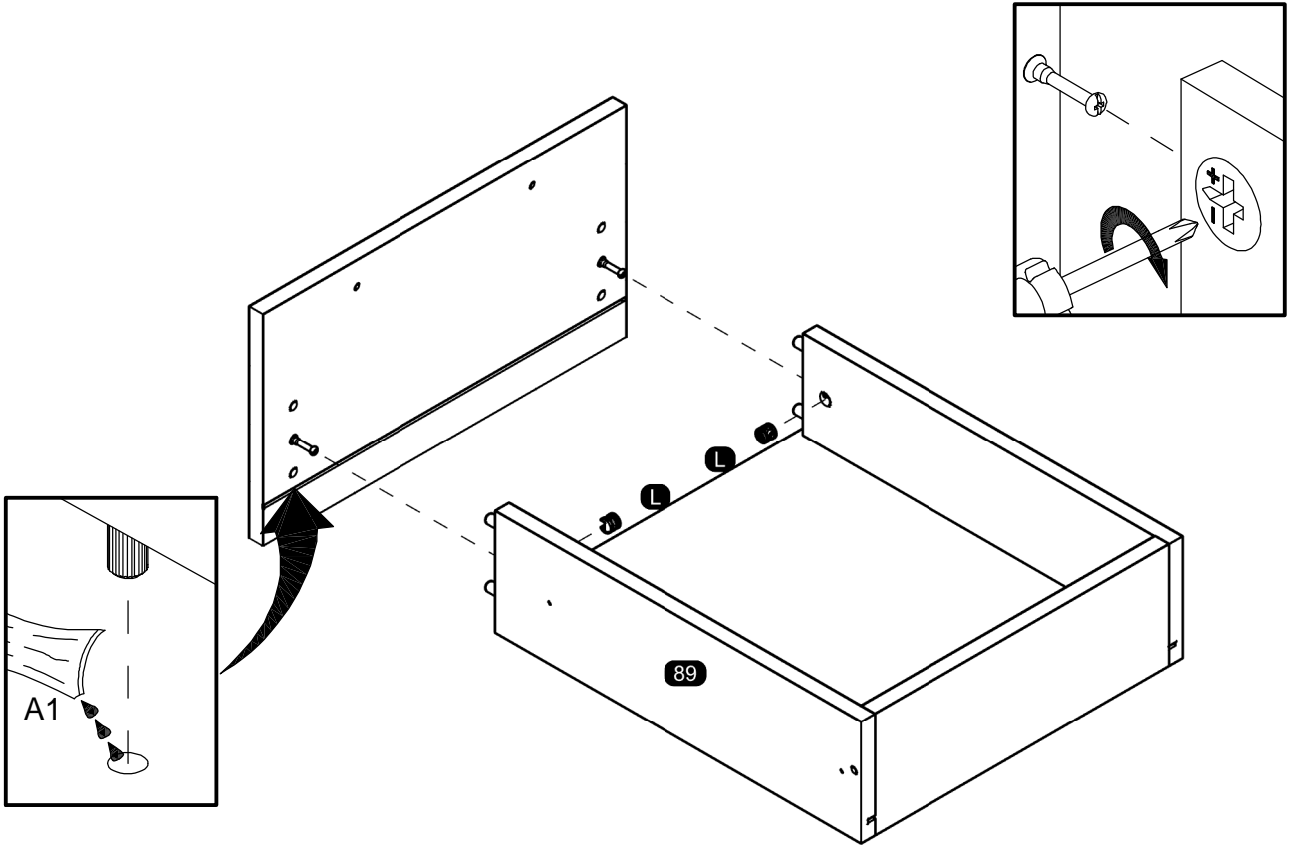

23

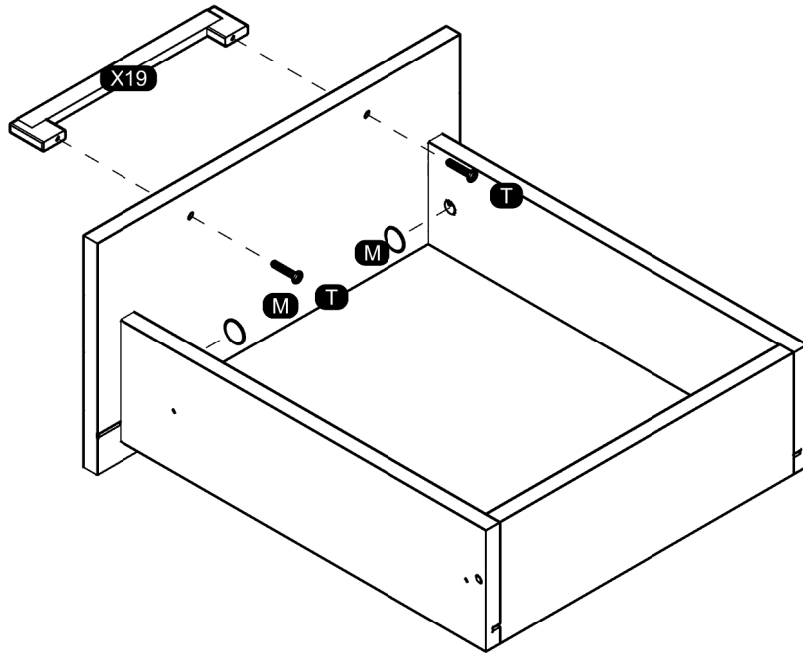

24

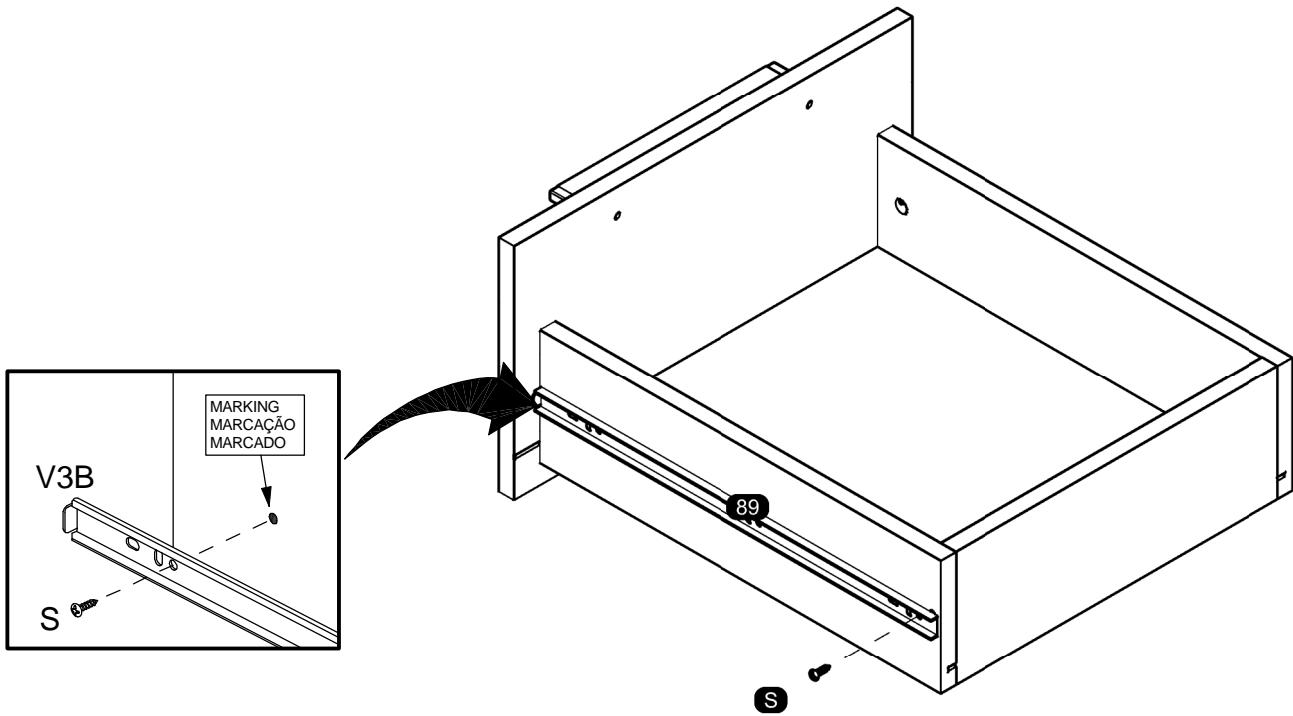

25

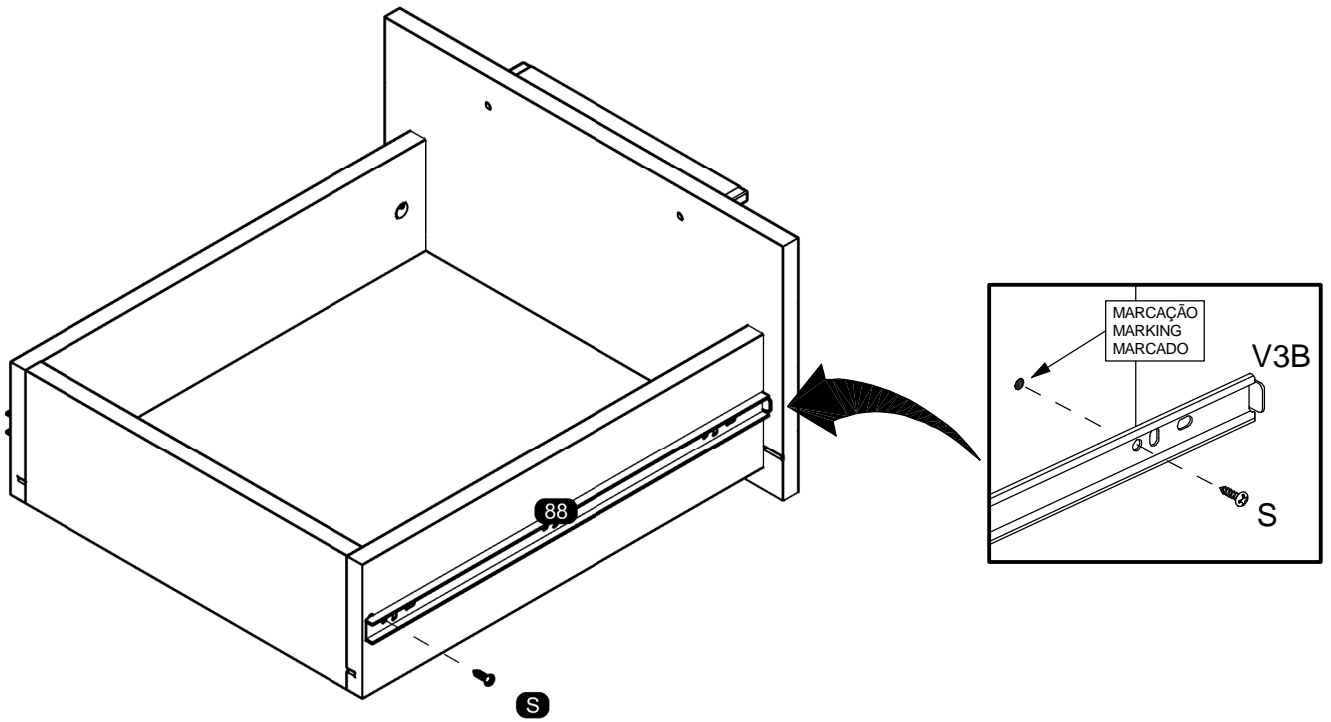

26

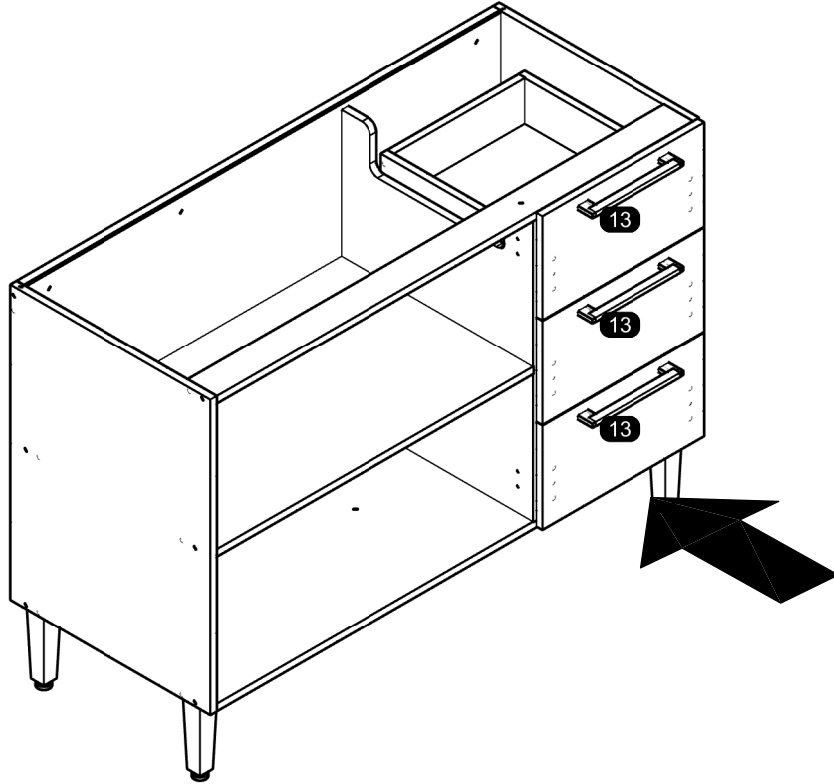

27

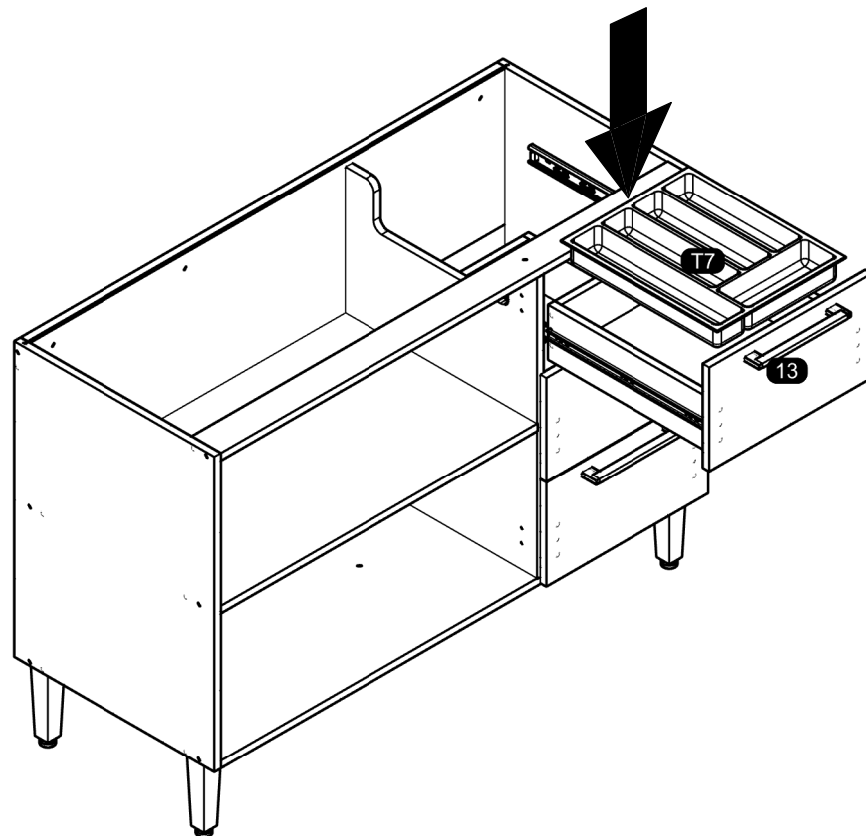

28

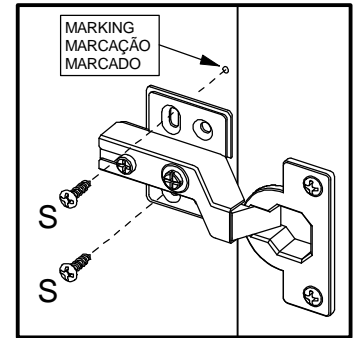
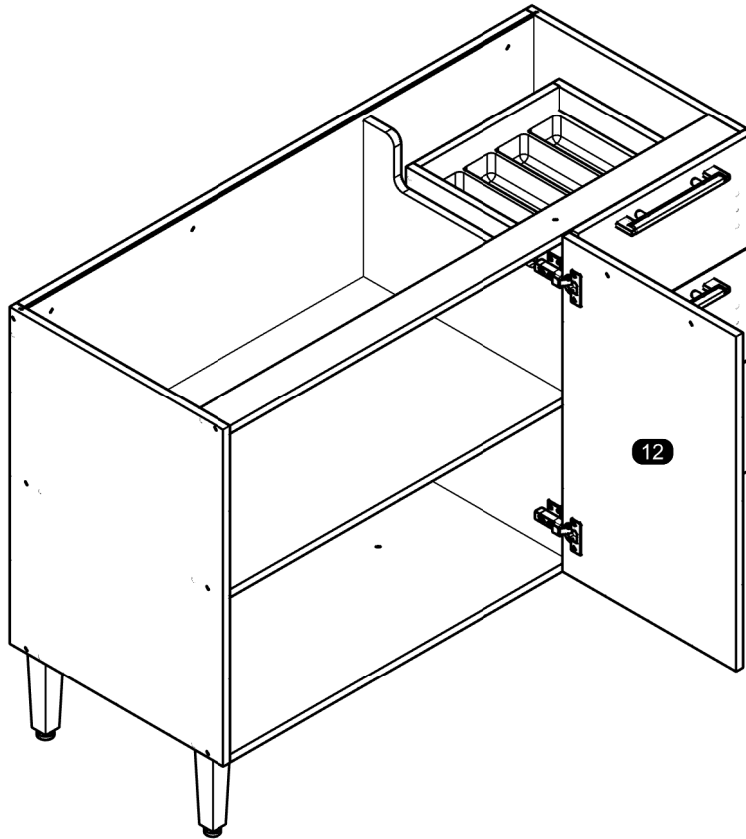

29

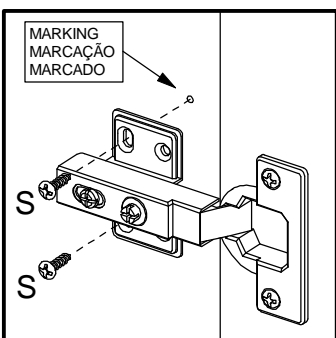
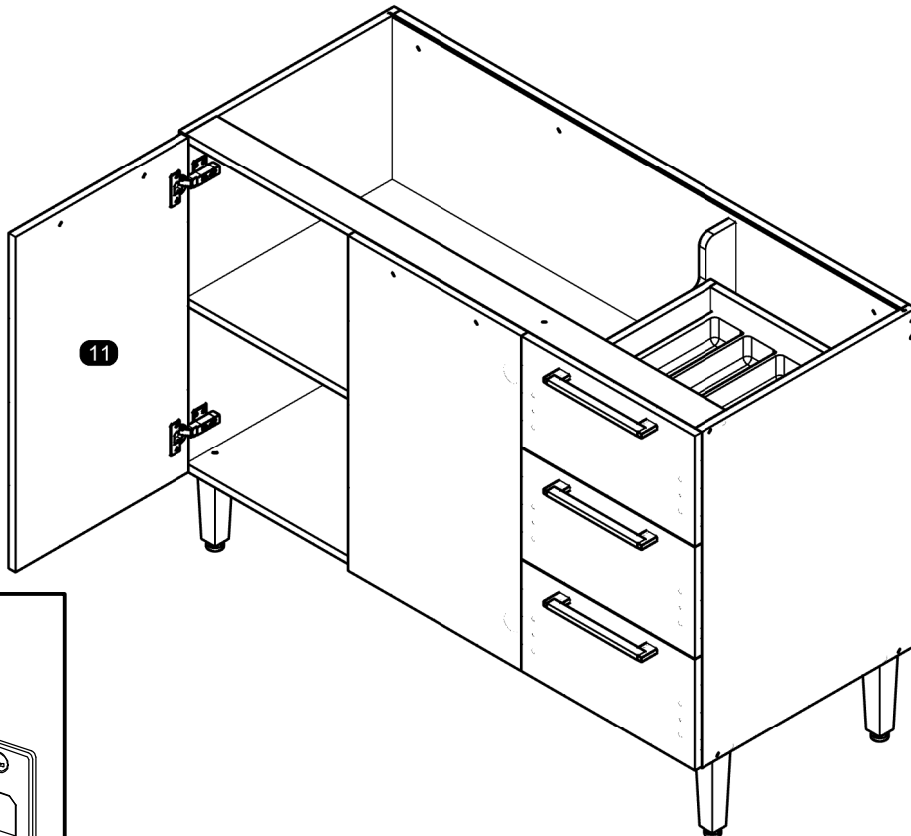

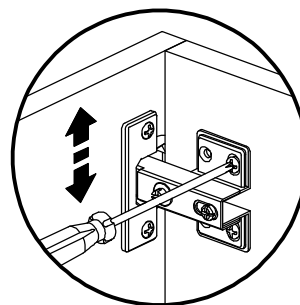
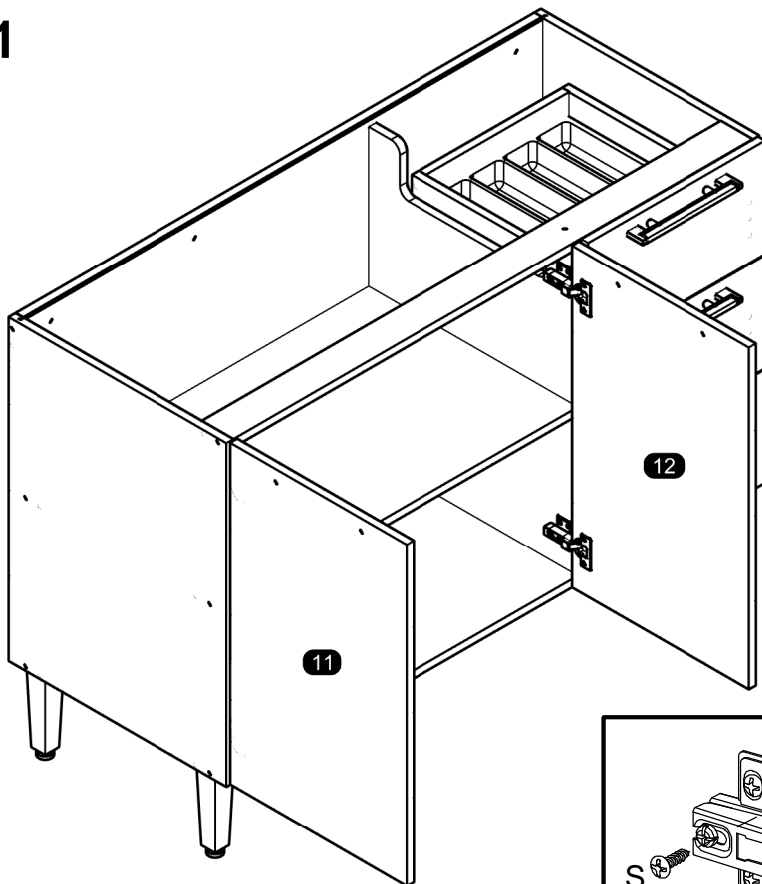
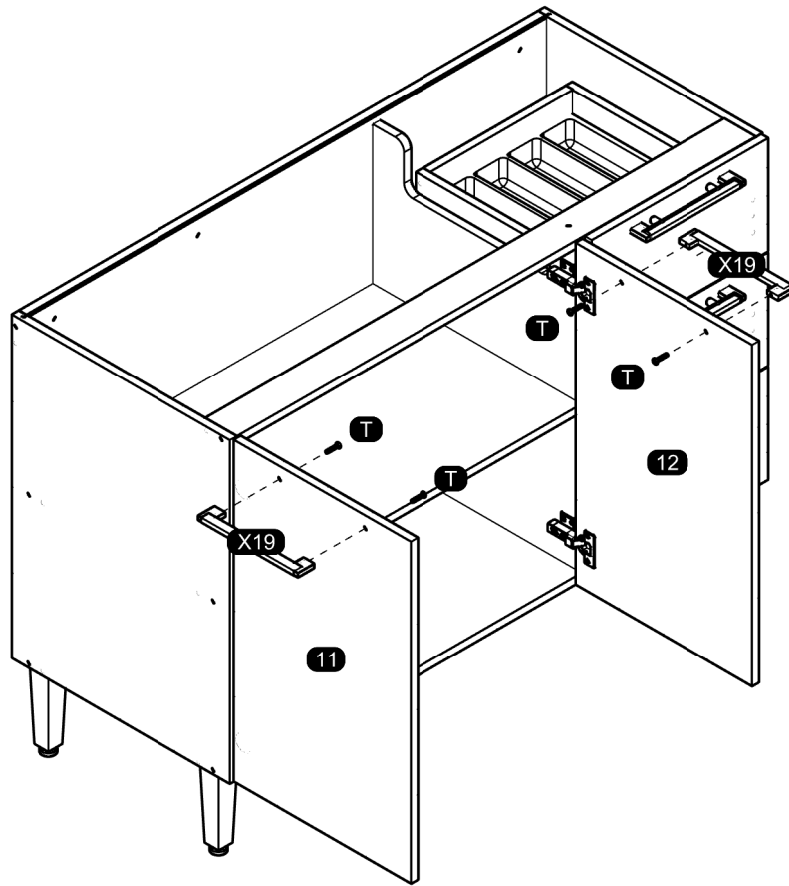

Vertical Adjustment
Regulagem Vertical
Ajuste Vertical

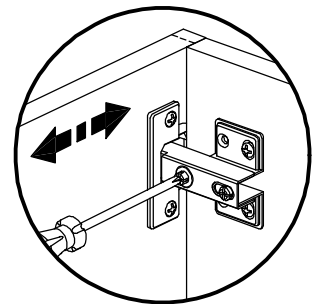

Horizontal Adjustment
Regulagem Horizontal
Ajuste Horizontal

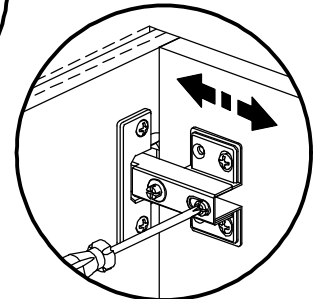

Depth Adjustment
Regulagem Profundidade
Ajuste Profundidade

