

ASSEMBLY INSTRUCTIONS

Ref.: 200453 - ELB0009.001 | Review 01

INSTRUCTIONS DE MONTAGE | MANUAL DE ARMADO | ESQUEMA DE MONTAGEM

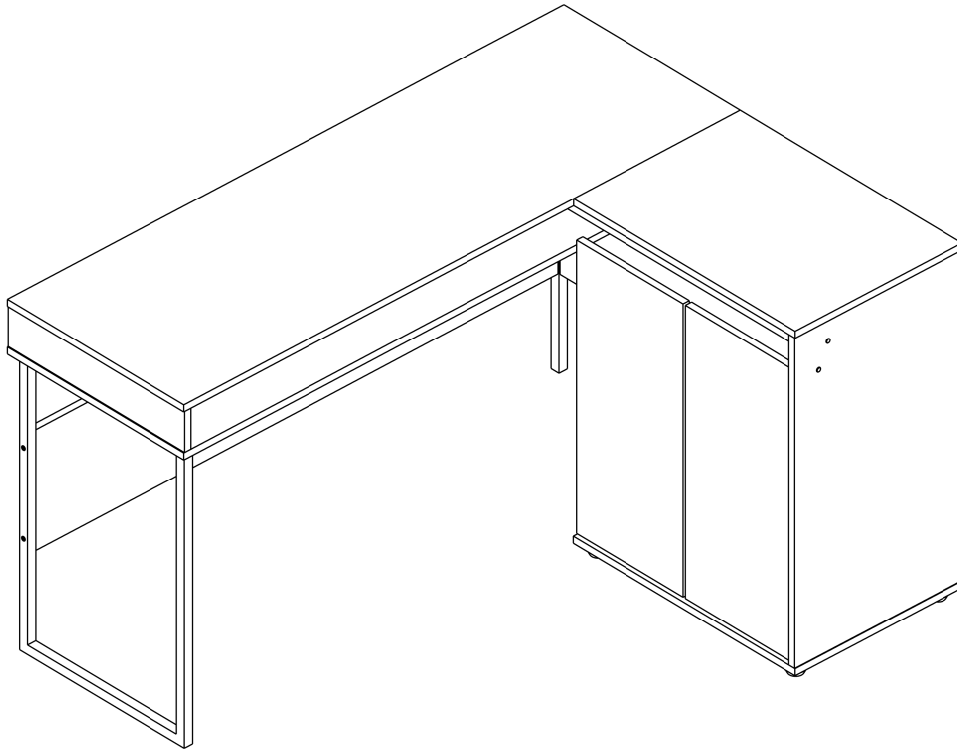

YOU WILL NEED

TU AURAS BESOIN DE | NECESITARÁ | VOCÊ VAI PRECISAR

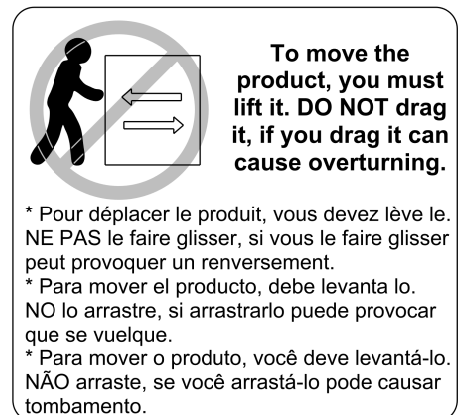
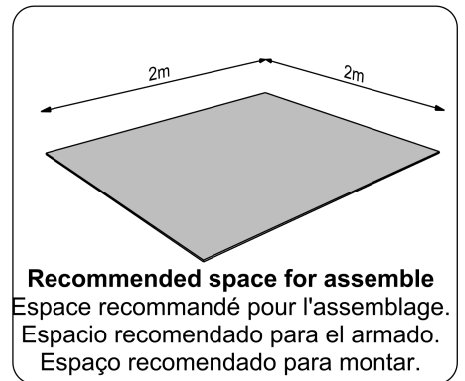
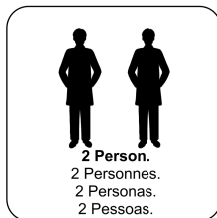
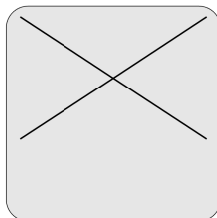
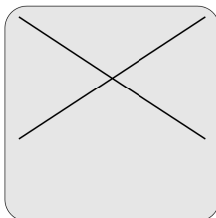
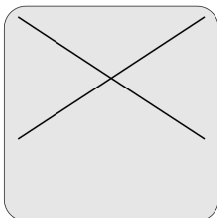
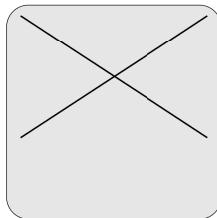
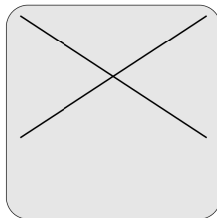
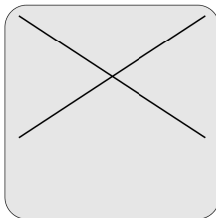
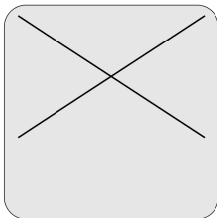
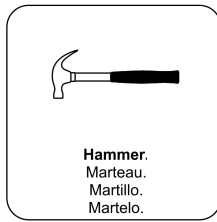
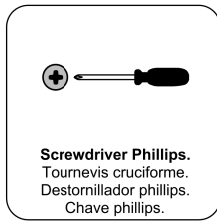
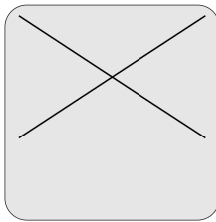
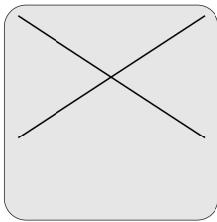

Tools not included

Outils non inclus | Herramientas no incluidas | Ferramentas não inclusas

PARTS IDENTIFICATION

IDENTIFICACION DES PIECES | IDENTIFICACIÓN DE PIEZAS | IDENTIFICAÇÃO DAS PEÇAS

01	Top Plan de Travail Tapa Tampo	Qty./Qtd. 01
02	Right Top Base Base Supérieure Droite Base Superior Derecha Base Superior Direita	Qty./Qtd. 01
03	Base Base Base Base	Qty./Qtd. 01
04	Left Tray Plateau Gauche Traviesa Izquierdo Travessa Esquerda	Qty./Qtd. 01
05	Right Tray Plateau Droite Traviesa Derecho Travessa Direita	Qty./Qtd. 01
06	Panel Panneau Panel Painel	Qty./Qtd. 01
07	Right Panel Panneau Droite Panel Derecho Painel Direito	Qty./Qtd. 01
08	Tray Plateau Traviesa Travessa	Qty./Qtd. 01
09	Shelf Étagère Repisa Prateleira	Qty./Qtd. 01
10	Bottom Base Base Inférieure Base Inferior Base Inferior	Qty./Qtd. 01
11	Left Side Côté Gauche Lateral Izquierdo Lateral Esquerda	Qty./Qtd. 01
12	Rear Tray Plateau Arrière Traviesa Posterior Travessa Traseira	Qty./Qtd. 01

13	Division Division División Divisória	Qty./Qtd. 01
14	Right Side Côté Droite Lateral Derecho Lateral Direita	Qty./Qtd. 01
15	Lateral Tray Plateau Latéral Traviesa Lateral Travessa Lateral	Qty./Qtd. 01
16	Door Porte Puerta Porta	Qty./Qtd. 02
17	Top Backboard Panneau Supérieure Fondo Superior Costa Superior	Qty./Qtd. 01
18	Backboard Panneau Fondo Trasero Costa	Qty./Qtd. 01

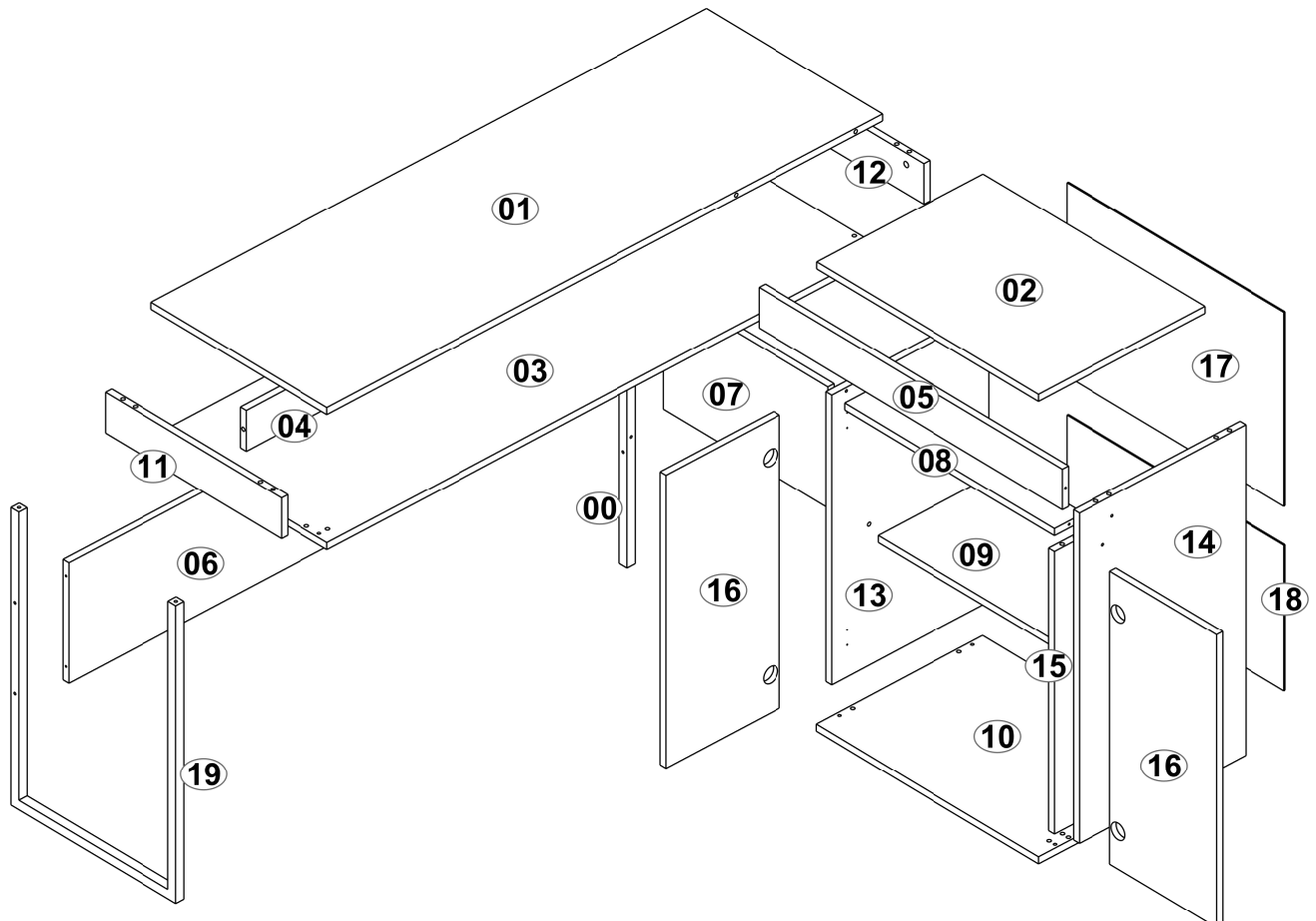

GENERAL DIMENSIONS | DIMENSIONS GÉNÉRALES | DIMENSIONES GENERALES | DIMENSÕES

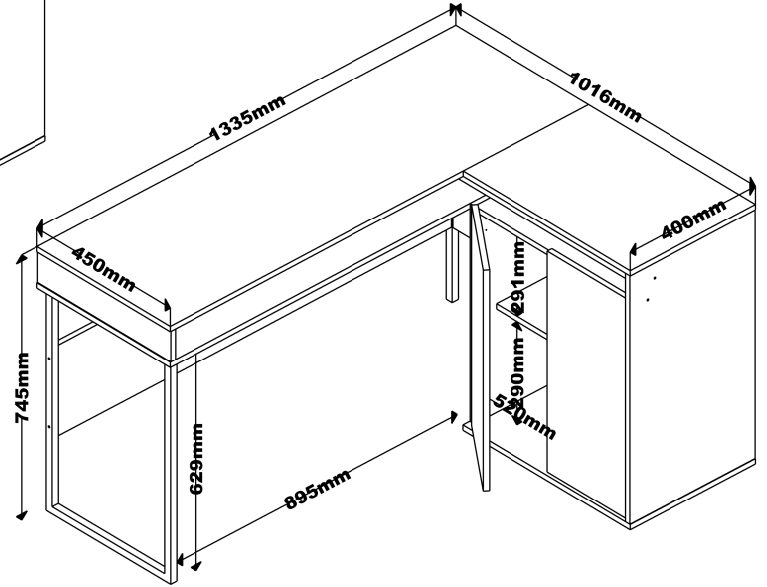
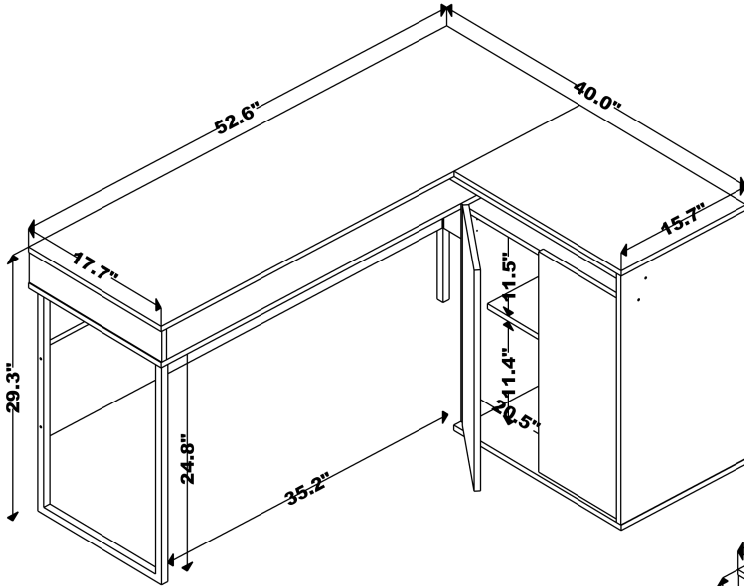

MAXIMUM RECOMMENDED WEIGHT BEING THIS EVENLY DISTRIBUTED.

LE POIDS MAXIMAL RECOMMANDÉ EST RÉGULIÈREMENT DISTRIBUÉ.

PESO MÁXIMO RECOMENDADO SIENDO ESTO UNIFORME REPARTIDO.

PESO MÁXIMO RECOMENDADO SENDO ESTE DISTRIBUIDO.

	LB	KG
A	44	20
B	11	5

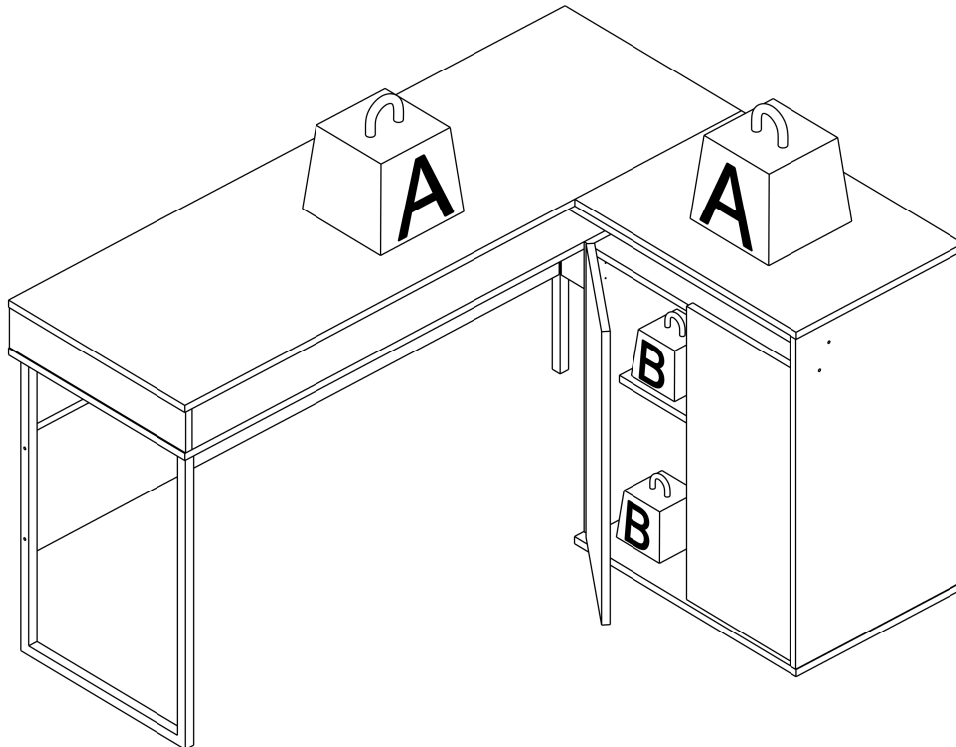

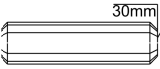

ACCESSORIES IDENTIFICATION

IDENTIFICATION DES ACCESSOIRES | IDENTIFICACIÓN DE ACCESORIOS | IDENTIFICAÇÃO DOS ACESSÓRIOS

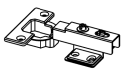
A  30mm Qty./Qtd. **26**
Wooden dowel / Chevilles en bois / Taquete / Caviha

Q  35mm Qty./Qtd. **4**
Metal hinge straight / Charnière métallique droite / Bisagra recta / Dobradiça Reta

AD  Qty./Qtd. **1**
Allen key / Clé Allen / Liave allen / Chave Allen

Z  Qty./Qtd. **5**
Metal claw / Pince de métal / Garra metal / Garra de Metal

AJ  Qty./Qtd. **3**
Screw / Visser / Tornillo / Parafuso

AN  50mm Qty./Qtd. **8**
Flanged head screw / Vis à tête bride / Tornillo de cabeza flangeada / Parafuso Flangeado

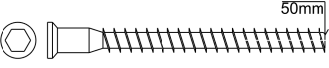
B  50mm Qty./Qtd. **6**
Structural screw / Vis à tête structurelle / Tornillo estructural / Parafuso Estructural

BC  Qty./Qtd. **4**
Plastic foot / Pied en Plastique / Pie plástico / Sapata Plástica

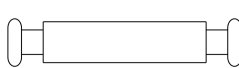
BD  Qty./Qtd. **2**
Minifix screw / Vis minifix / Tornillo minifix / Haste Minifix

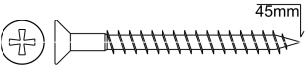
C  45mm Qty./Qtd. **8**
Structural screw / Vis à tête structurelle / Tornillo estructural / Parafuso Estructural

F  Qty./Qtd. **6**
Structural screw cover/Cache-vis structurel/Tapa tornillo estructural/ Tampa estrutural

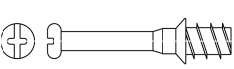
G  Qty./Qtd. **6**
Simple minifix screw / Vis minifix simple / Tornillo minifix simple / Haste Minifix Simples

H  Qty./Qtd. **10**
Drum lock / Verrouillage du tambour / Tambor minifix / Tambor de Minifix

i  Qty./Qtd. **10**
Bore patch adhesive / Adhésif de correction d'alésage / Tapones adhesivo/ Adesivo Tapa Furo

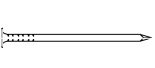
J  10 x 10 Qty./Qtd. **30**
Nail / Ongle / Clavo / Prego

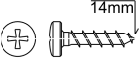
N  14mm Qty./Qtd. **16**
Pan head screw / Vis à tête bombée / Tornillo de pan / Parafuso Panela

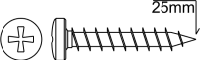
O  25mm Qty./Qtd. **4**
Pan head screw / Vis à tête bombée / Tornillo de pan / Parafuso Panela

Separating the accessories before starting the assembly will make it easier.

Séparer les accessoires avant de commencer le montage vous facilitera la tâche.

Separar los accesorios antes de comenzar el montaje lo hará más fácil.

Separar os acessórios antes de iniciar a montagem facilitará.



PRE-ASSEMBLY - PRÉ-ASSEMBLAGE - PRE-ARMADO PRÉ-MONTAGEM

- 01 - *Fix accessory (**A**) to part 03.
*Fixez l'accessoire (**A**) à la pièce 03.
*Fijar accesorio (**A**) a pieza 03.
*Fixe o acessório (**A**) na peça 03.

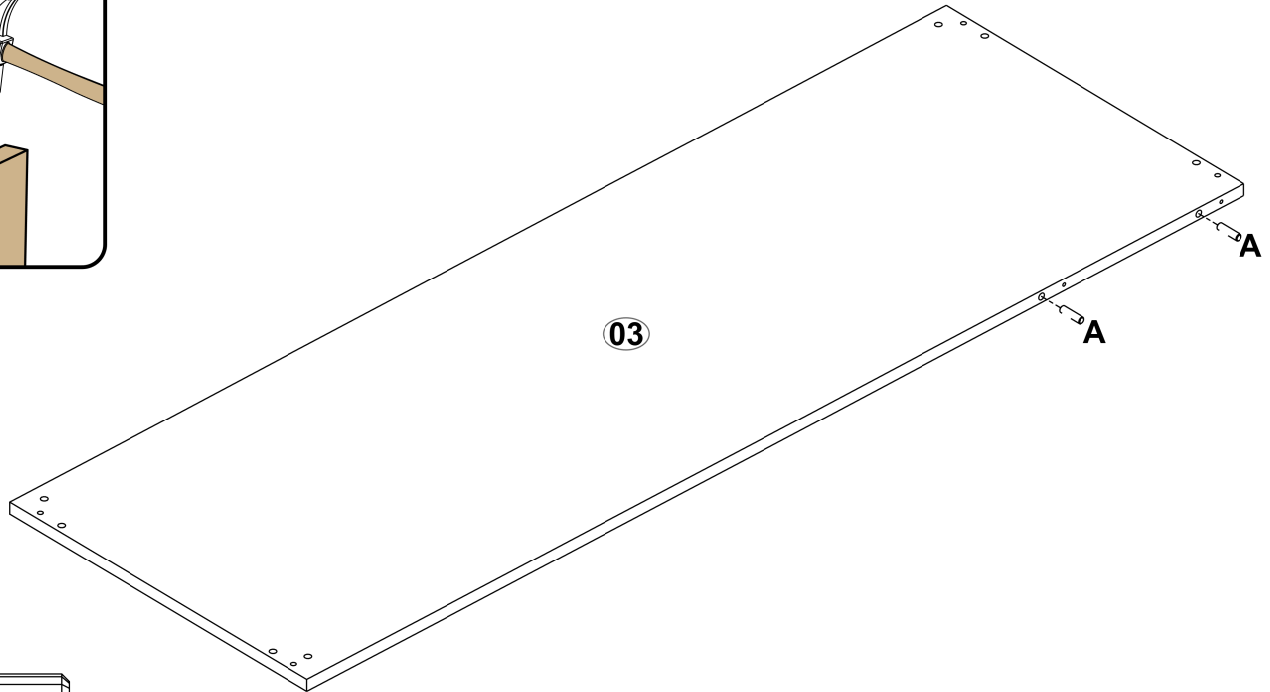
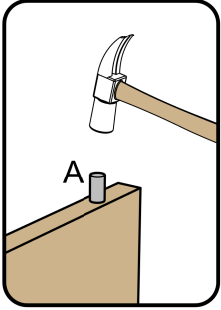

- 02 - *Fix accessory (**G**) to part 01.
*Fixez l'accessoire (**G**) à la pièce 01.
*Fijar accesorio (**G**) a pieza 01.
*Fixe o acessório (**G**) na peça 01.

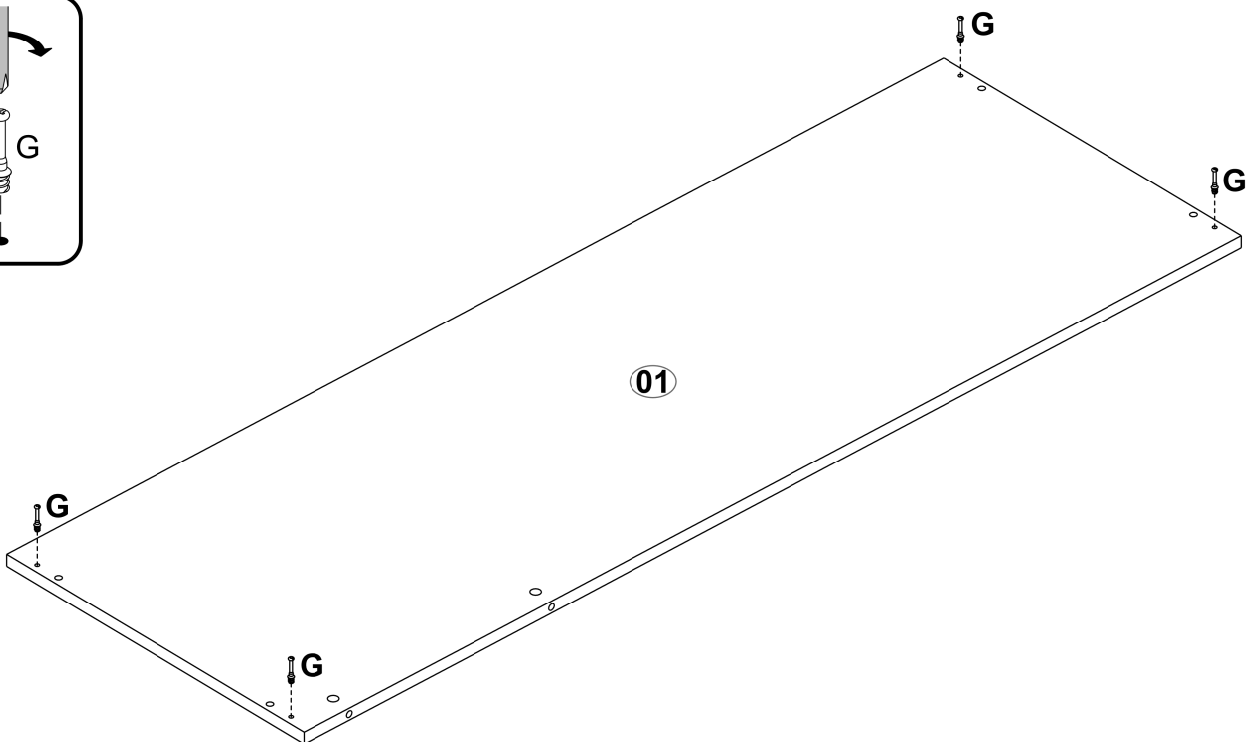
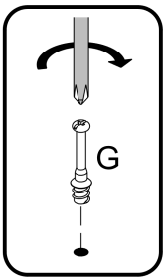

- 03** - *Fix accessory (**G**) to part **02**.
*Fixez l'accessoire (**G**) à la pièce **02**.
*Fijar accesorio (**G**) a pieza **02**.
*Fixe o acessório (**G**) na peça **02**.

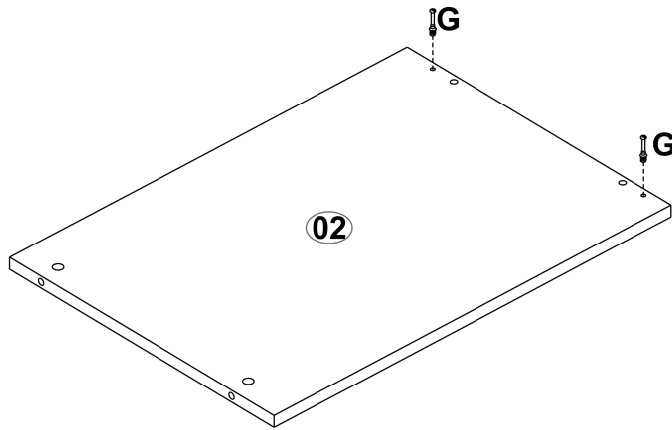
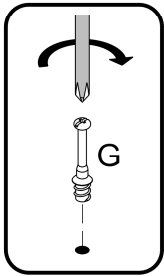

- 04** - *Fix accessory (**A**) to part **04**.
*Fixez l'accessoire (**A**) à la pièce **04**.
*Fijar accesorio (**A**) a pieza **04**.
*Fixe o acessório (**A**) na peça **04**.

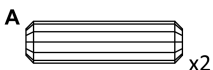
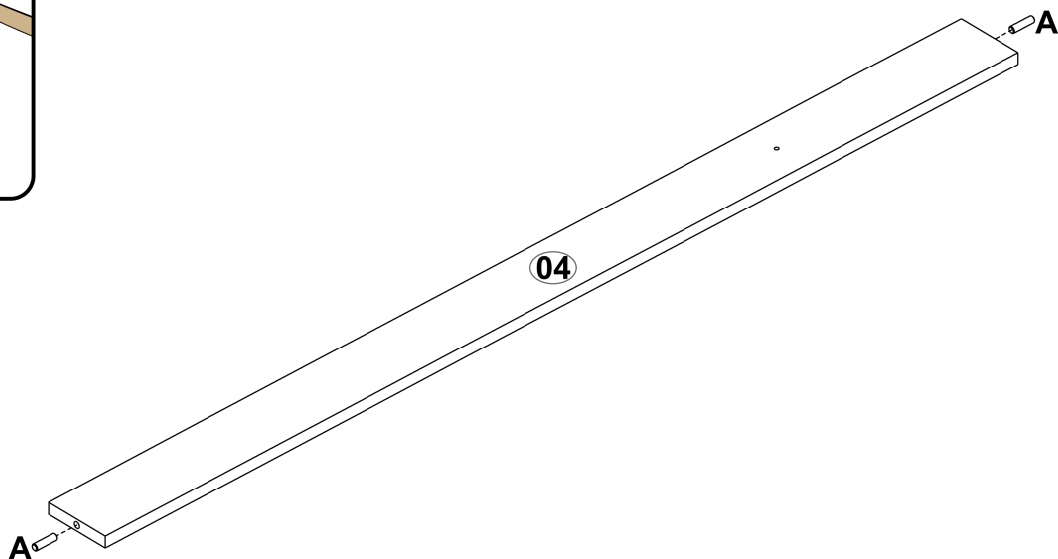
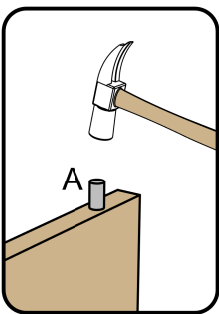

- 05 -** *Fix accessory (**A**) to part **15**.
 *Fixez l'accessoire (**A**) à la pièce **15**.
 *Fijar accesorio (**A**) a pieza **15**.
 *Fixe o acessório (**A**) na peça **15**.

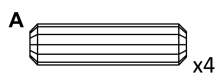
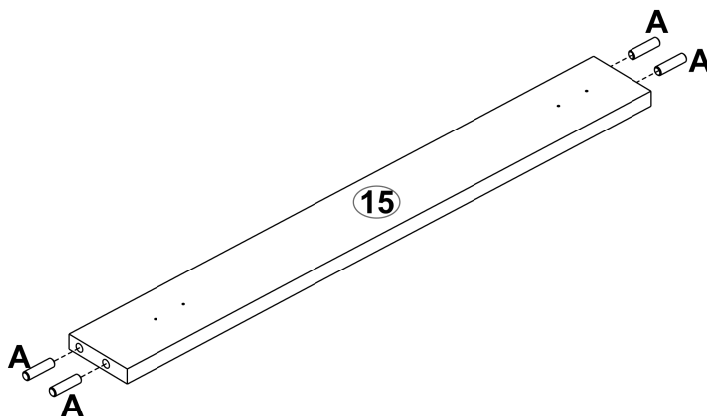
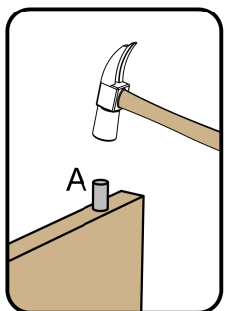

- 06 -** *Fix accessory (**A**) to part **11**.
 *Fixez l'accessoire (**A**) à la pièce **11**.
 *Fijar accesorio (**A**) a pieza **11**.
 *Fixe o acessório (**A**) na peça **11**.

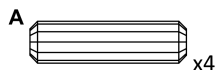
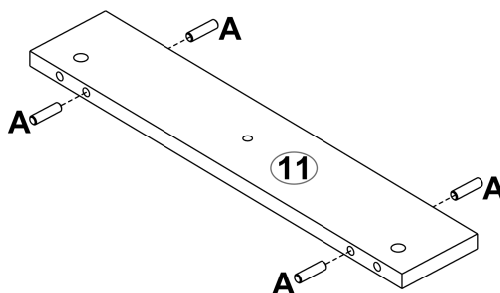
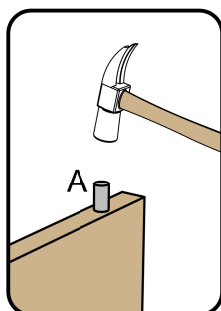

- 07 - *Fix accessory (**A**) to part **14**.
*Fixez l'accessoire (**A**) à la pièce **14**.
*Fijar accesorio (**A**) a pieza **14**.
*Fixe o acessório (**A**) na peça **14**.

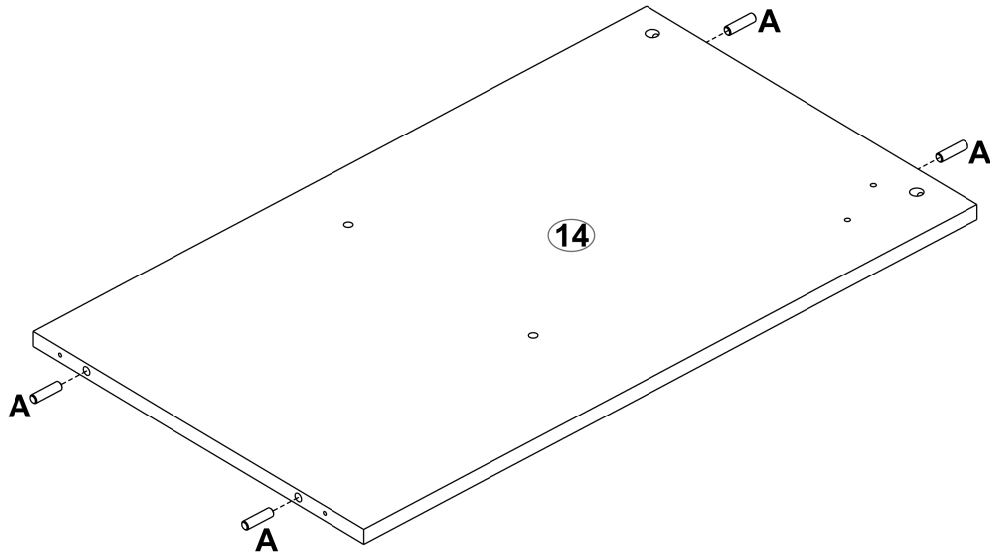
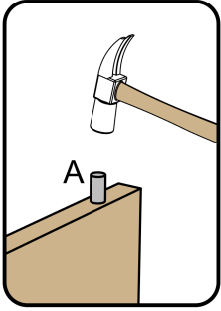

- 08 - *Fix accessory (**A**) to part **12**.
*Fixez l'accessoire (**A**) à la pièce **12**.
*Fijar accesorio (**A**) a pieza **12**.
*Fixe o acessório (**A**) na peça **12**.

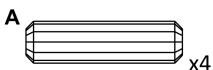
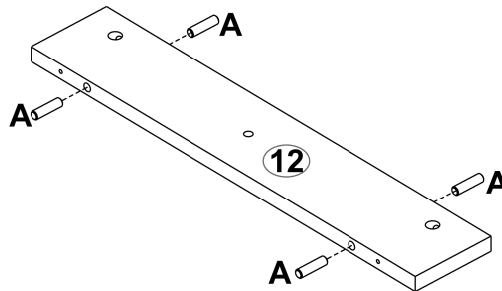
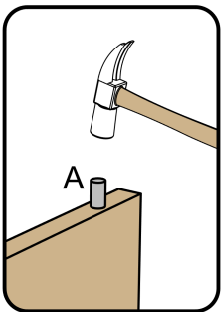

- 09** - *Fix accessory (**A**) to part **09**.
 *Fixez l'accessoire (**A**) à la pièce **09**.
 *Fijar accesorio (**A**) a pieza **09**.
 *Fixe o acessório (**A**) na peça **09**.

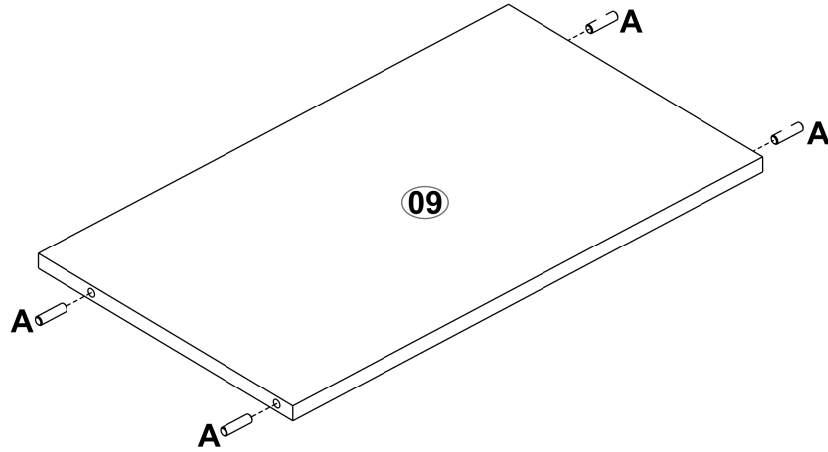
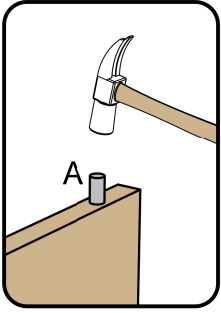

- 10** - *Fix accessory (**BC**) with accessory (**O**) to part **10**.
 *Fixez l'accessoire (**BC**) avec l'accessoire (**O**) à la pièce **10**.
 *Fijar accesorio (**BC**) con accesorio (**O**) a pieza **10**.
 *Fixe o acessório (**BC**) com o acessório (**O**) na peça **10**.

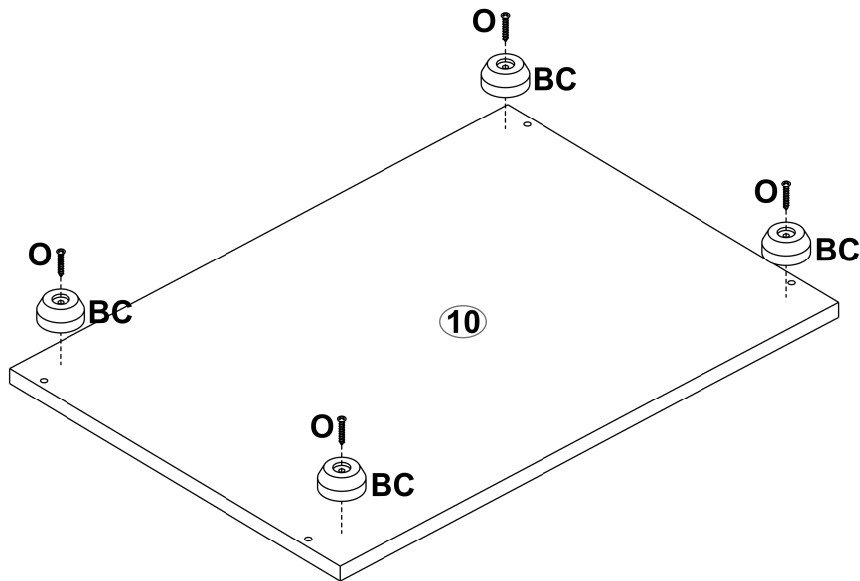

- 11 - *Fix accessory (Q) with accessory (N) to part 16.
 *Fixez l'accessoire (Q) avec l'accessoire (N) à la pièce 16.
 *Fijar accesorio (Q) con accesorio (N) a pieza 16.
 *Fixe o acessório (Q) com o acessório (N) na peça 16.

2x

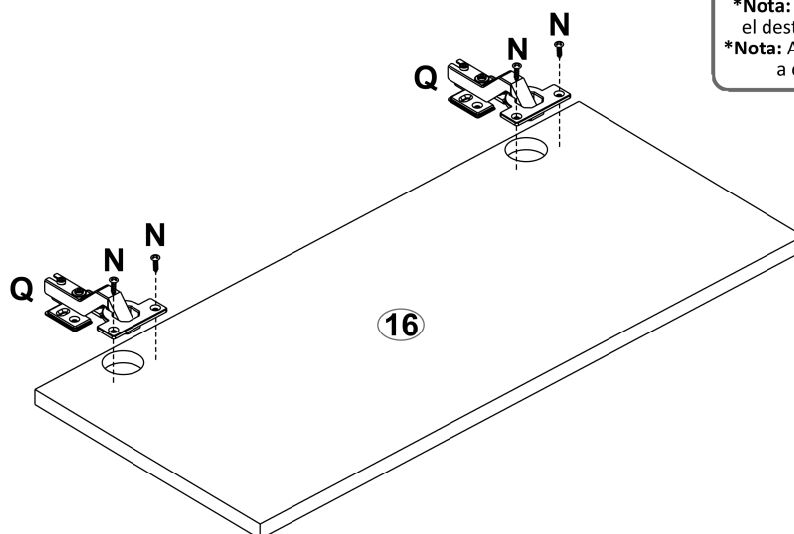

*Note: the missing holes must be made with the screwdriver and the corresponding screw.
 *Remarque: Les trous manquants doivent être faits avec le tournevis et la vis correspondante.
 *Nota: los agujeros faltantes deben hacerse con el destornillador y el tornillo correspondiente.
 *Nota: As furações faltantes devem ser feitas com a chave e o parafuso correspondente.

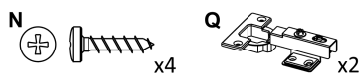

- 12 - *Fix accessory (A) to part 13.
 *Fixez l'accessoire (A) à la pièce 13.
 *Fijar accesorio (A) a pieza 13.
 *Fixe o acessório (A) na peça 13.

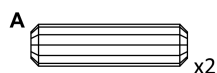
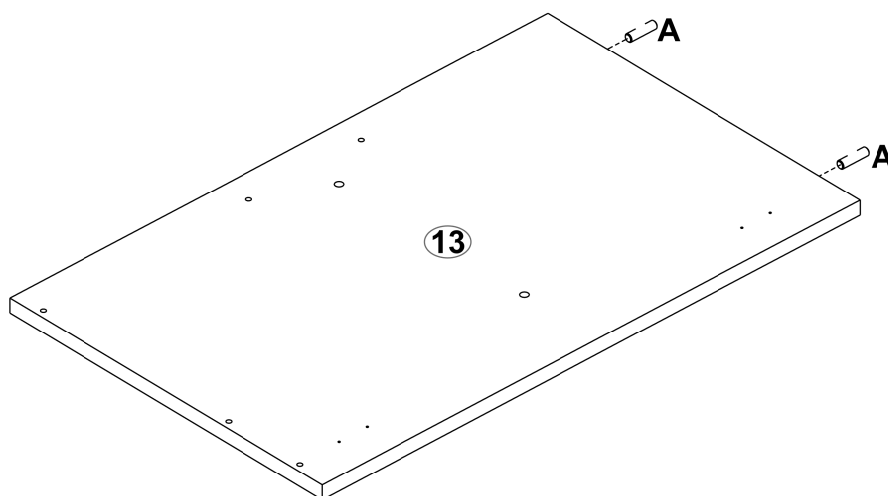
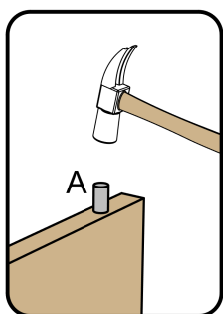

ASSEMBLY - MONTAGE - ARMADO - MONTAGEM

- 13 - *Fix part 04, part 05, part 11 and part 12 with the accessory (B).
 *Fixez la pièce 04, la pièce 05, la pièce 11 et la pièce 12 avec l'accessoire (B).
 *Fijar pieza 04, pieza 05, pieza 11 y pieza 12 con el accesorio (B).
 *Fixe a peça 04, a peça 05, a peça 11 e a peça 12 com o acessório (B).

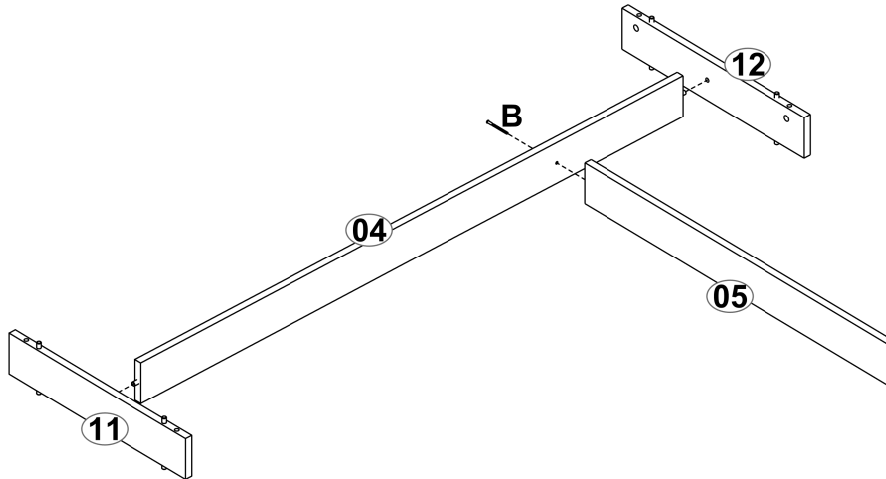
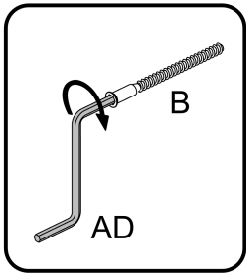

- 14 - *Fix part 19 and part 20 with the accessory (AJ) and part 03 with the accessory (C).
 *Fixez la pièce 19, et la pièce 20 avec l'accessoire (AJ) et la pièce 03 avec l'accessoire (C).
 *Fijar pieza 19 y pieza 20 con el accesorio (AJ) y pieza 03 con el accesorio (C).
 *Fixe a peça 19 e a peça 20 com o acessório (AJ) e a peça 03 com o acessório (C).

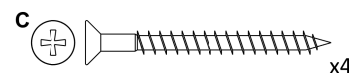
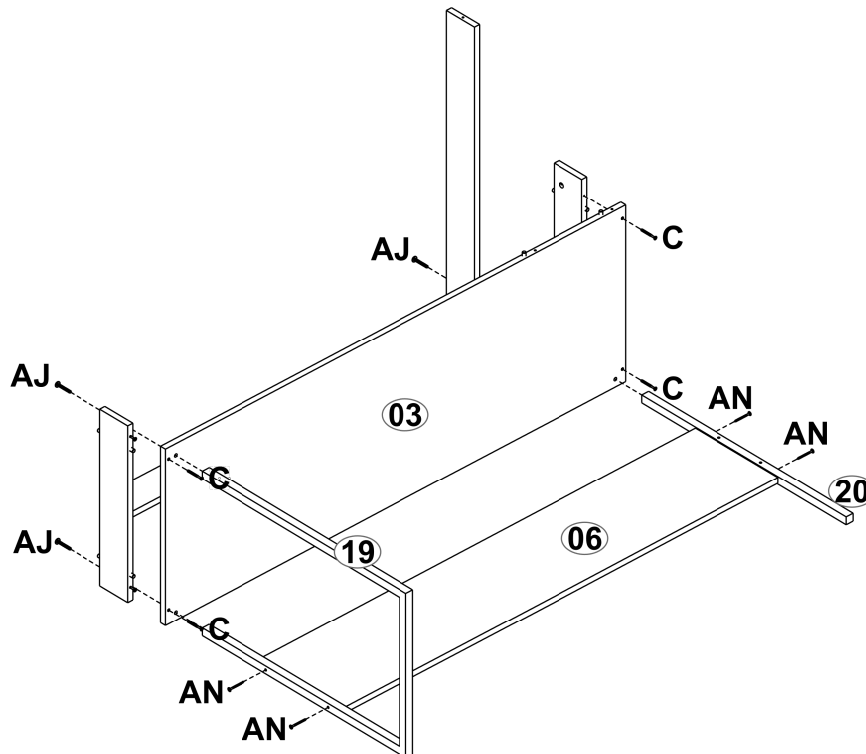

- 15 - *Fix part 07 to previous assembly with the accessory (AN) and part 01 with the accessory (H).
 *Fixez la pièce 07 à l'assemblage précédent avec l'accessoire (AN) et la pièce 01 avec l'accessoire (H).
 *Fijar pieza 07 a ensamble previo con el accesorio (AN) y pieza 01 con el accesorio (H).
 *Fixe a peça 07 na montagem anterior com o acessório (AN) e a peça 01 com o acessório (H).

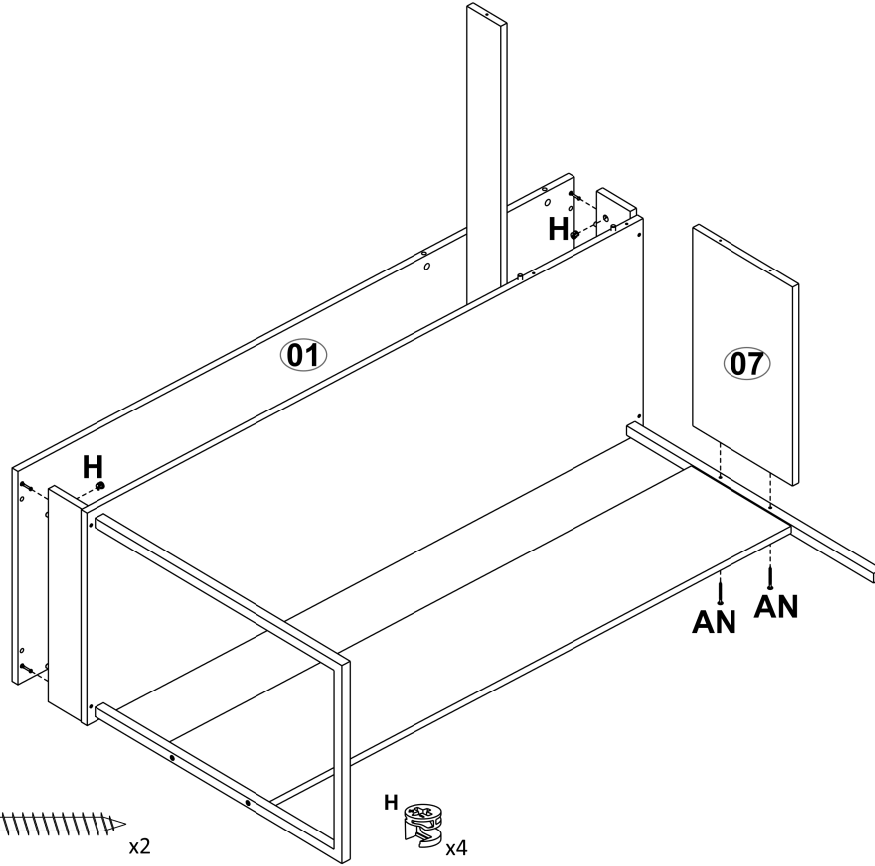
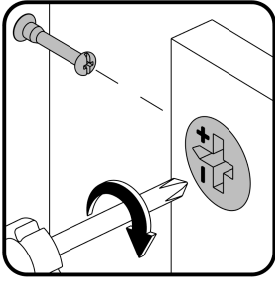

- 16 - *Fix part 08, part 09, part 13, part 14 and part 15 with the accessory (B) and part 02 with the accessory (H).
 *Fixez la pièce 08, la pièce 09, la pièce 13, la pièce 14 et la pièce 15 avec l'accessoire (B) et la pièce 02 avec l'accessoire (H).
 *Fijar pieza 08, pieza 09, pieza 13, pieza 14 y pieza 15 con el accesorio (B) y pieza 02 con el accesorio (H).
 *Fixe a peça 08, a peça 09, a peça 13, a peça 14 e a peça 15 com o acessório (B) e a peça 02 com o acessório (H).

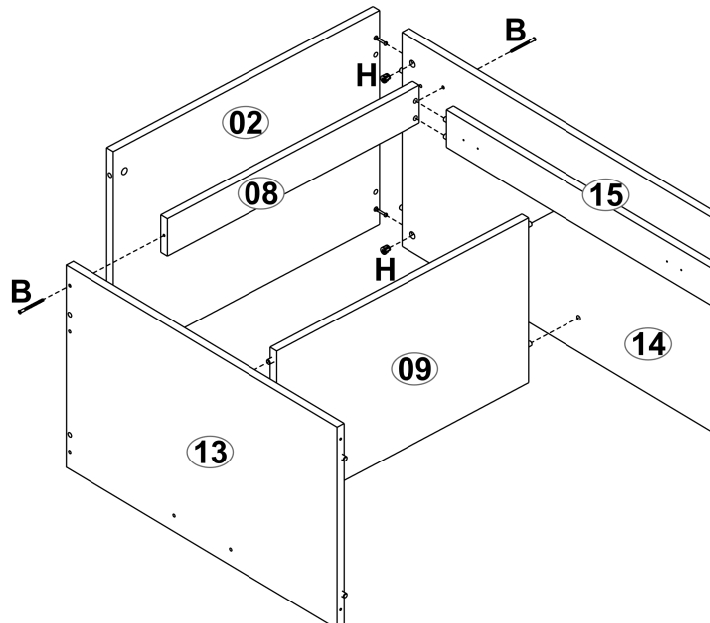
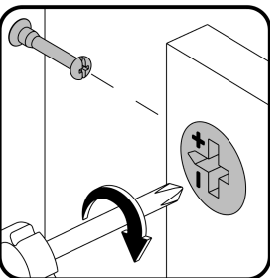
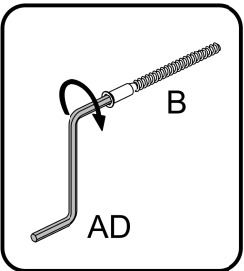

- 17 - *Fix part 10 to previous assembly with the accessory (C).
 *Fixez la pièce 10 à l'assemblage précédent avec l'accessoire (C).
 *Fijar pieza 10 a ensamble previo con el accesorio (C).
 *Fixe a peça 10 na montagem anterior com o acessório (C).

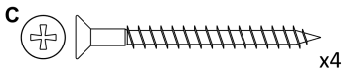
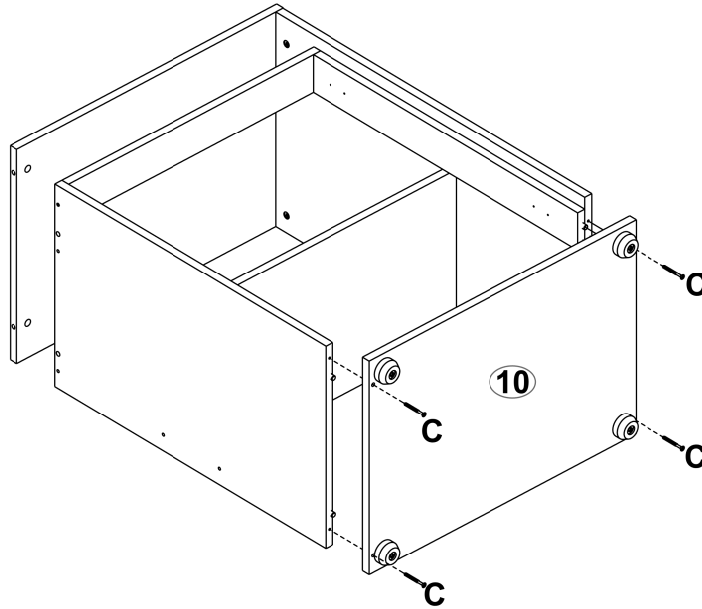

- 18 - *Fix previously assemblies (steps 15 and 17) with the accessory (H).
 *Fixez assemblages précédents (étapes 15 et 17) avec l'accessoire (H).
 *Fijar ensambles previos (pasos 15 y 17) con el accesorio (H).
 *Junte as montagens anteriores (passos 15 e 17) com o acessório (H).

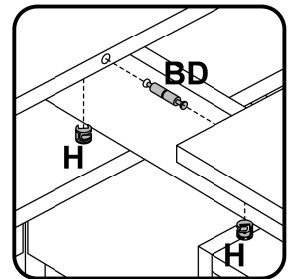
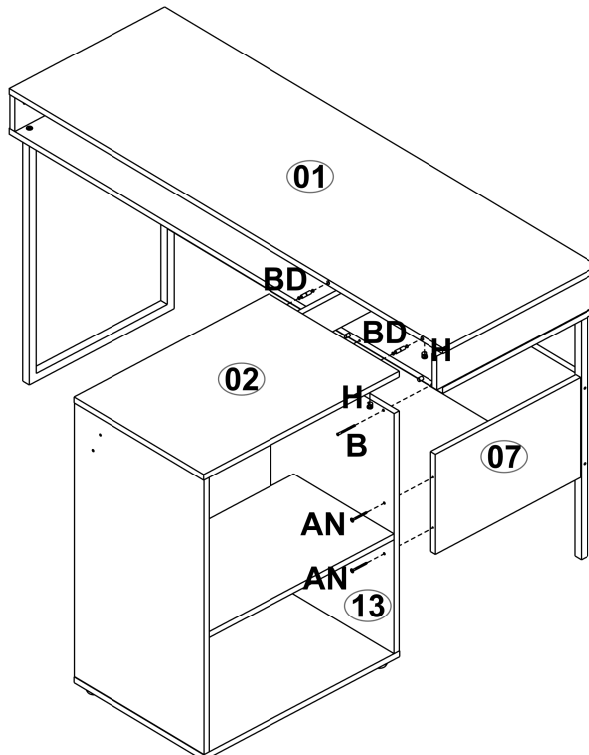
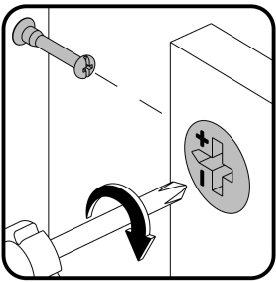

- 19 - *Fix part 17 and part 18 to previous assembly with the accessory (J).
 *Fixez la pièce 17 et la pièce 18 à l'assemblage précédent avec l'accessoire (J).
 *Fijar pieza 17 y pieza 18 a ensamble previo con el accesorio (J).
 *Fixe a peça 17 e a peça 18 na montagem anterior com o acessório (J).

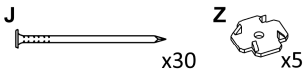
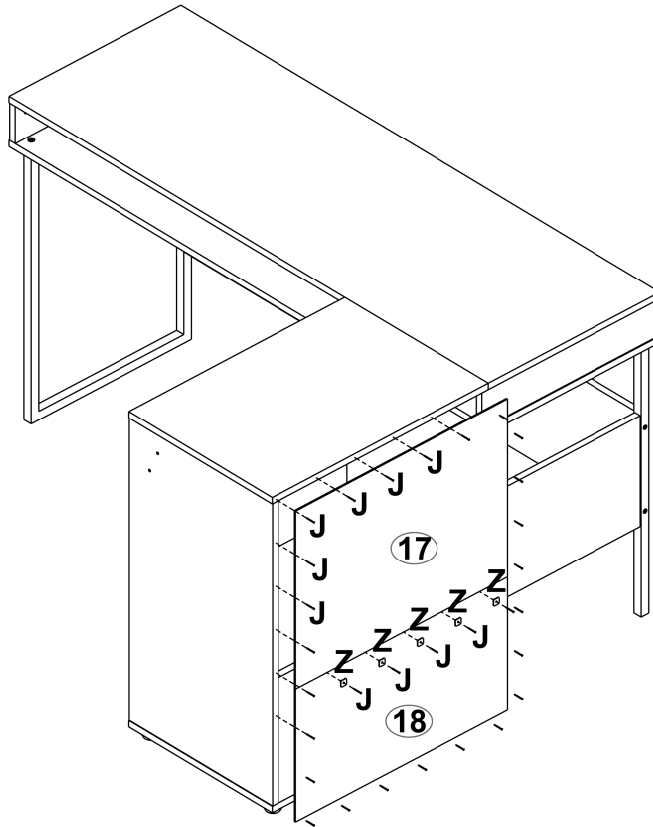

- 20 - *Fix part 16 to previous assembly with the accessory (N).
 *Fixez la pièce 16 à l'assemblage précédent avec l'accessoire (N).
 *Fijar pieza 16 a ensamble previo con el accesorio (N).
 *Fixe a peça 16 na montagem anterior com o acessório (N).

