

A ESCRIVANINHA POSSUI UM (1) PISTÃO A GAS EM CADA LADO.

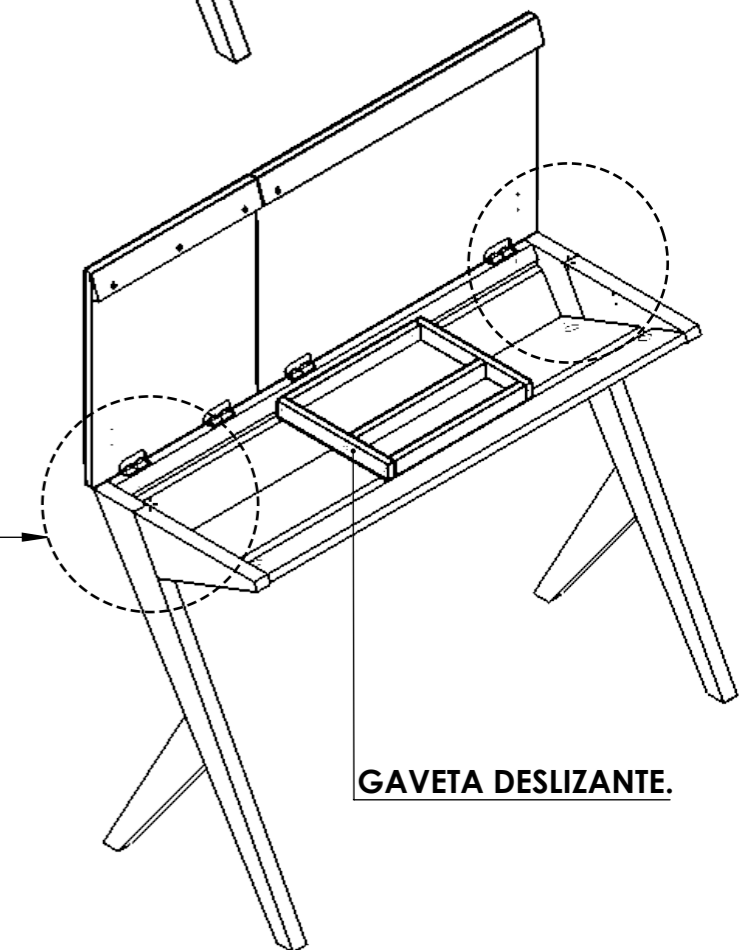

GAVETA DESLIZANTE.

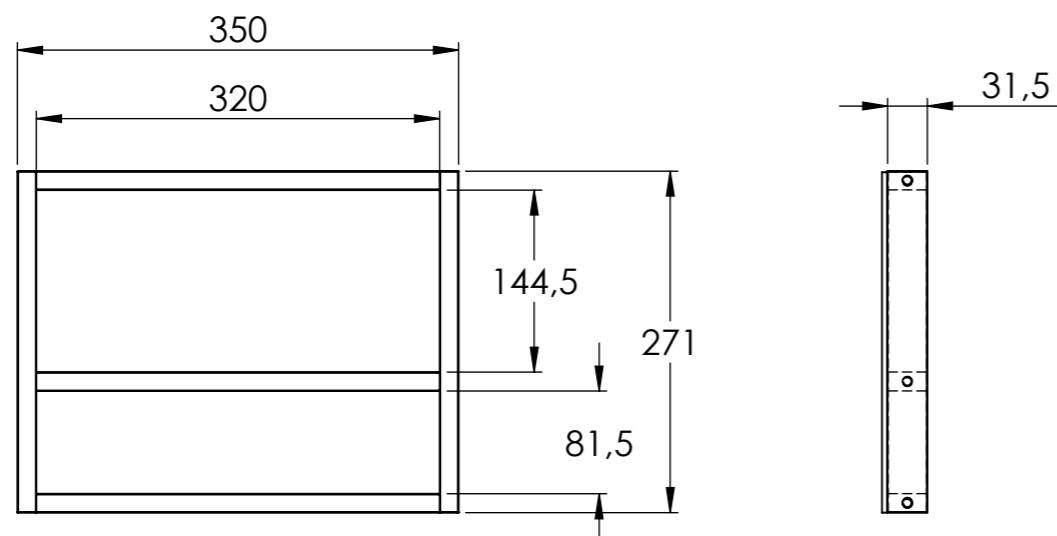

GAVETA
(Área útil)

Projetista: ALOIS

Data: 28/08/2020

Produto:
650.126.0001 - ESCRIVANINHA SLIM

Componente:
ESCRIVANINHA MONTADA



ESL

Qtde: **01**

Material:
DIVERSOS

Dimensões:
1085 x 488 x 750 mm