

HENN

Ind. e Com. de Móveis Henn
Mondai - SC - Brasil

+55 49 3674.3500

@moveishenn
www.henn.com.br

INSTRUÇÕES DE MONTAGEM

INSTRUCCIONES DE MONTAJE
ASSEMBLY INSTRUCTIONS

Balcão Pia 03 Gavetas 02 portas Americana |
Pia Contador 03 Cajones 02 Puertas Americana | Balcony Pia 03 Drawers 02 Doors Americana |

C353-05 Branco HP
C353-131 Cinza

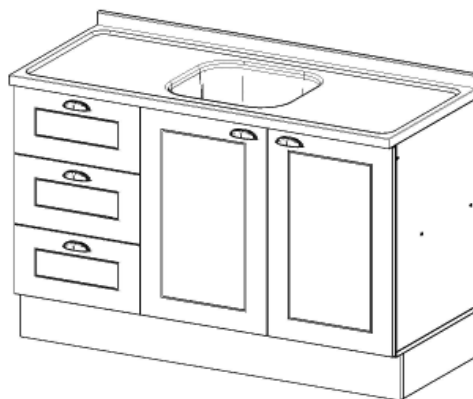
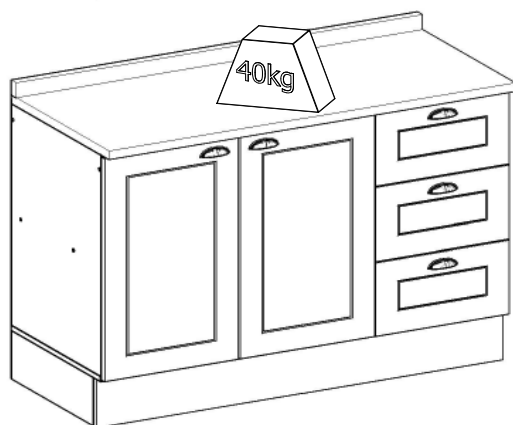
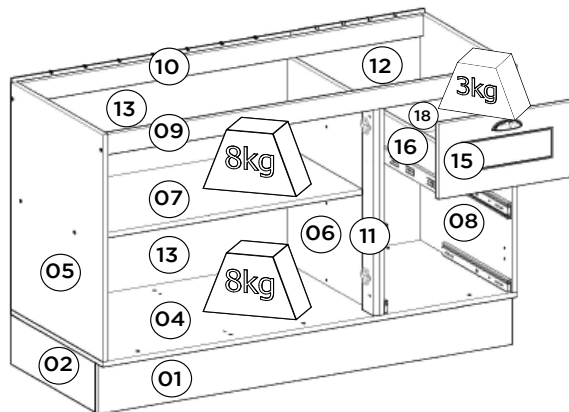
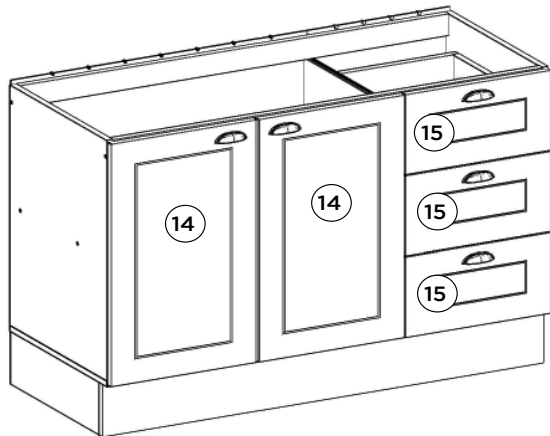

Pesos máximos recomendados
com carga distribuída
Peso máximo recomendado con la
carga distribuída
Recommended maximum weights
with evenly distributed.

Requisitos para montagem
Requisitor para la montaje
Assembly Requirements

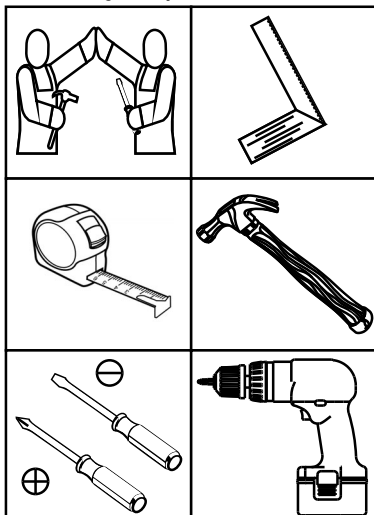

Imagens meramente ilustrativas
Imágenes meramente ilustrativas
Images for illustration only

AVISO

Para limpeza de seu móvel, use uma flanela seca ou umedecida, e não utilize produtos químicos que possam danificar seu produto.

SISTEMA DE MONTAGEM

O sistema de montagem dos produtos, funciona de acordo com a ordem crescente dos números indicados no desenho. Ex: 01, 02, 03, 04... até a conclusão da montagem.

ASSISTÊNCIA TÉCNICA

Para solicitação de Assistência Técnica você consumidor deverá entrar em contato com o Lojista o qual você realizou a compra deste produto e solicitar a assistência técnica das peças avariadas. A garantia abrange todas as peças, partes e componentes que eventualmente venham apresentar defeito de fabricação no prazo de 03 (três) meses, contando a partir da entrega do produto ao consumidor, mediante nota fiscal de compra. Se houver qualquer alteração na estrutura do produto ou ocorrer defeito por negligência do montador/consumidor em relação a instrução de montagem e manuseio, não será fornecido assistência técnica gratuita.

ADVERTENCIA

Para limpieza de su móvil, use una flanela seca o húmeda, y no utilice productos químicos que puedan dañar su producto.

SISTEMA DE MONTAJE

El sistema de montaje de los productos funciona de acuerdo con el orden creciente de los números indicados en el dibujo. Ej.: 01, 02, 03, 04... hasta la conclusión del montaje.

ASISTENCIA TÉCNICA

Para solicitar Asistencia Técnica, el consumidor debe comunicarse con el Comercio que usted realizó la compra de este producto y solicita asistencia técnica para las partes dañadas. La garantía cubre todas las partes, piezas y componentes que eventualmente puedan presentar defecto de fabricación en el plazo de 03 (tres) meses, contados a partir de la entrega del producto al consumidor, mediante factura de compra. Si se produce algún cambio en la estructura del producto o se produce un defecto por negligencia del montador/consumidor en relación con las instrucciones de montaje y manipulación, no se prestará asistencia técnica gratuita.

NOTICE

To clean your furniture, use a dry or wet cloth, and do not use chemicals that may damage your product.

ASSEMBLY SYSTEM

The products' assembly system works according to the increasing order of the indicated numbers. For example: 01, 02, 03, 04 ... to the end of the assembly.

TECHNICAL ASSISTANCE

To request Technical Assistance, the consumer must contact the retailer from whom you purchased this product and request technical assistance for the damaged parts. The warranty covers all parts, parts and components that may eventually present a manufacturing defect within a period of 03 (three) months, counting from the delivery of the product to the consumer, by means of a purchase invoice. If there is any change in the structure of the product or defect occurs due to negligence of the assembler/consumer in relation to the assembly and handling instruction, free technical assistance will not be provided.

1º

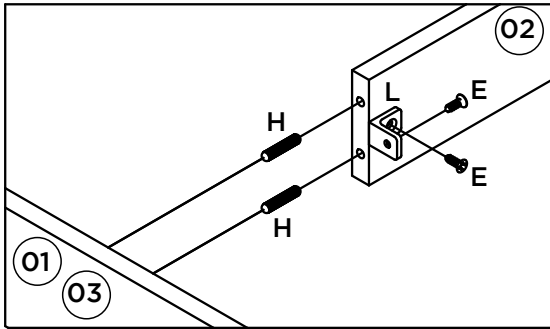
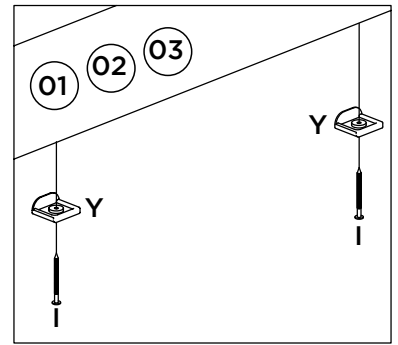
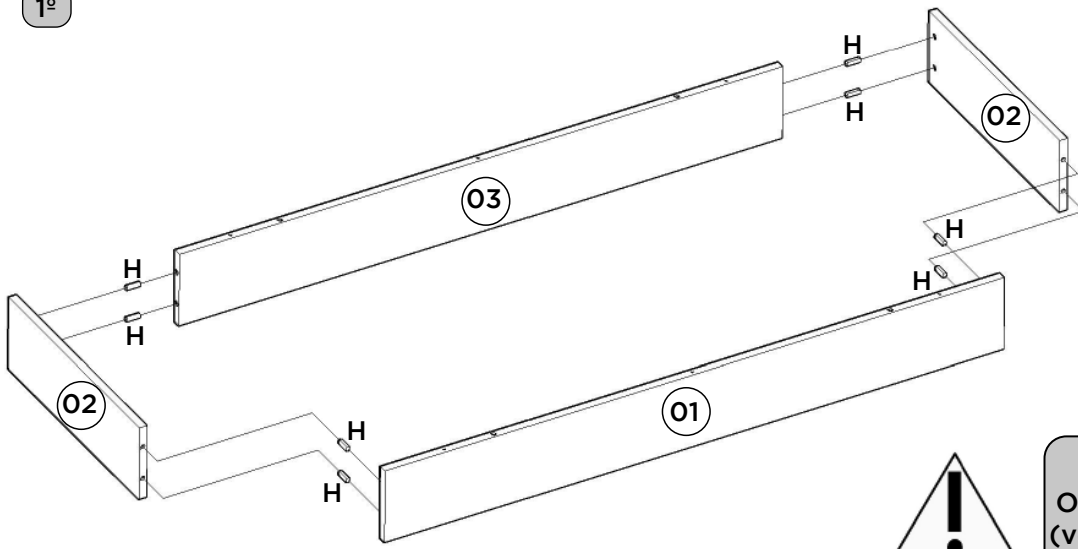

OPCIONAL:
 O945-121 Kit Pé Cônico 145mm (vendido separadamente). Caso opte em colocar pé no produto, utilizar as pré-furações que possui na Base e fixá-lo com o Parafuso que consta no Kit.

OPCIONAL:
 O945-121 Kit Pie Cónico 145mm (se vende por separado). Si opta por colocar pie en el producto, utilizar las pre-huracuras que tenga en la Base y fijarlo con el Tornillo que consta en el Kit.

OPTIONAL:
 O945-121 Tapered Foot Kit 145mm (sold separately). If you choose to put foot in the product, use the pre-drillings in the Base and fix it with the Screw included in the Kit.

2º

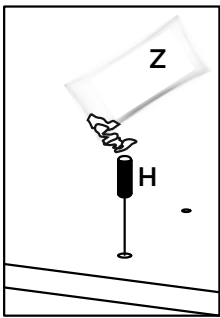

- Utilizar o sachê de cola (Z) em todas as cavilhas (H) do produto.
- Con el pegamento sobre (Z) en todos los pernos (H) producto.
- Use the glue sachet (Z) on all the pegs (H) of the product.

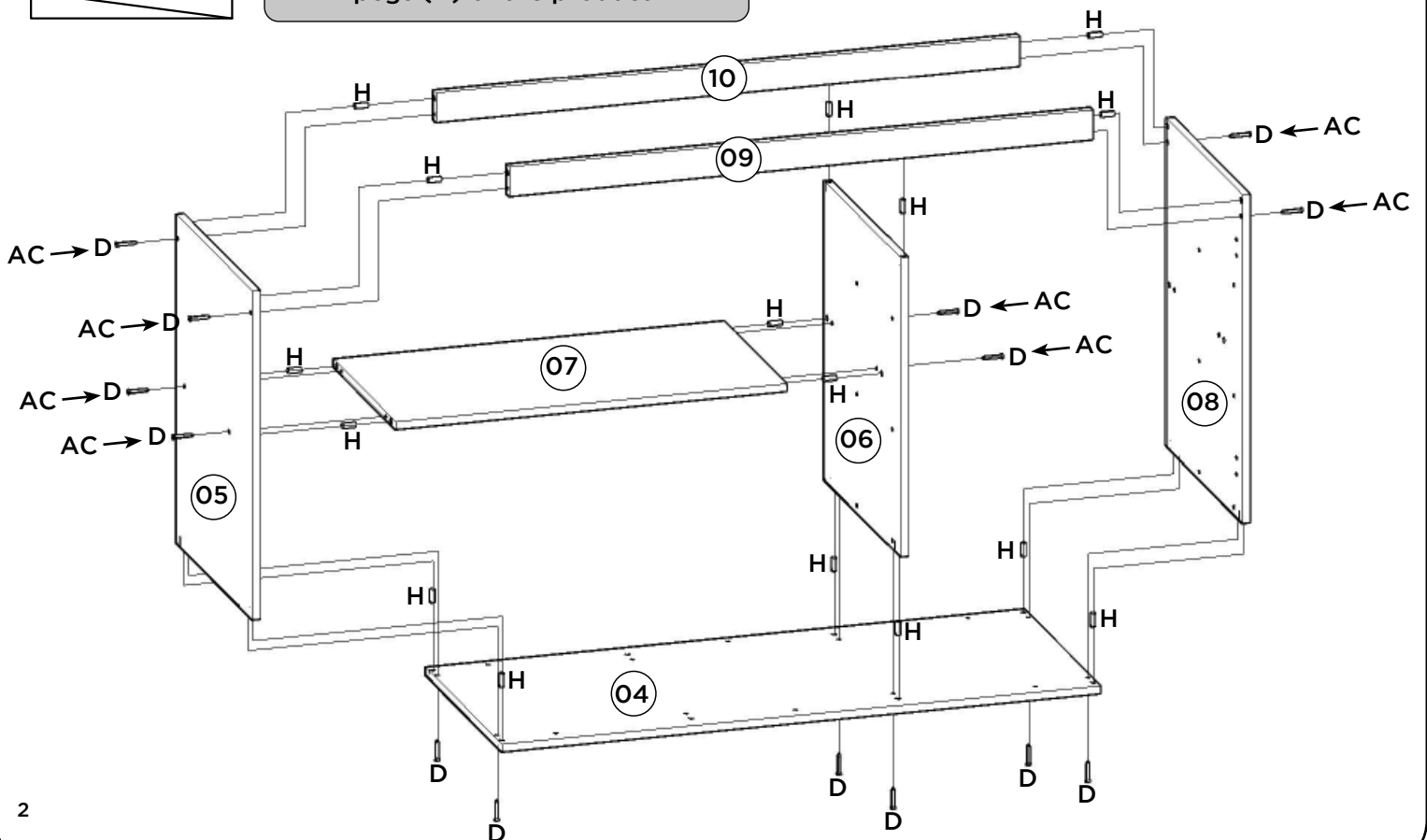

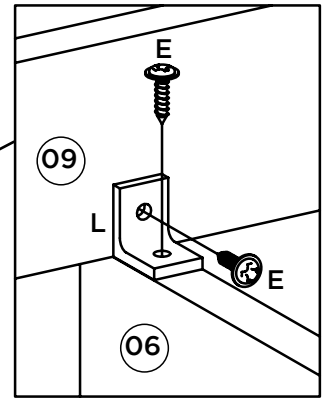
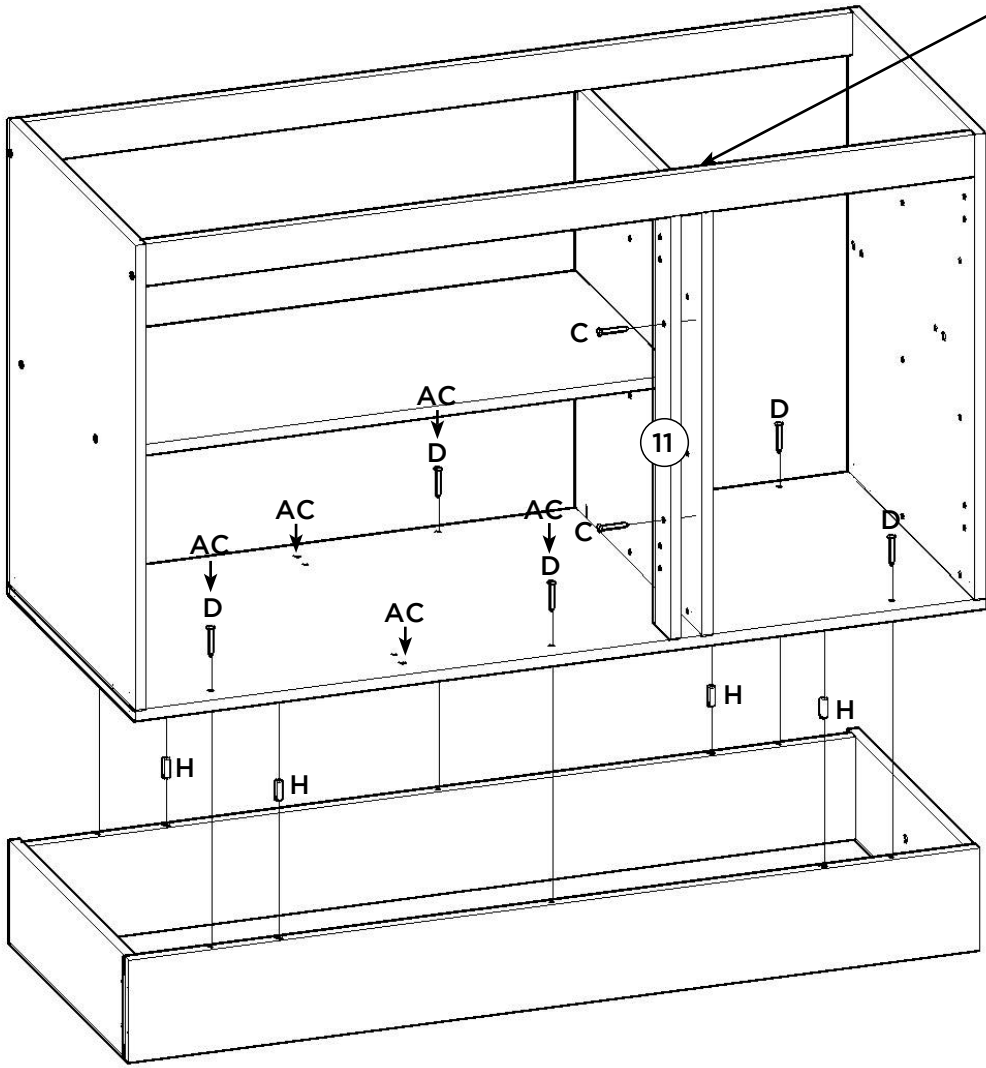

A pilastra da porta (11) deve estar alinhada com a divisão (06).

El pilar de la puerta (11) debe estar alineada con la división (06).

The door pillar (11) must be aligned with the partition (06).

4º

Esse tampo é opcional e é vendido separadamente (C905-114).

Esta vez es opcional y se vende por separado (C905-114).

This top is optional and is sold separately (C905-114).

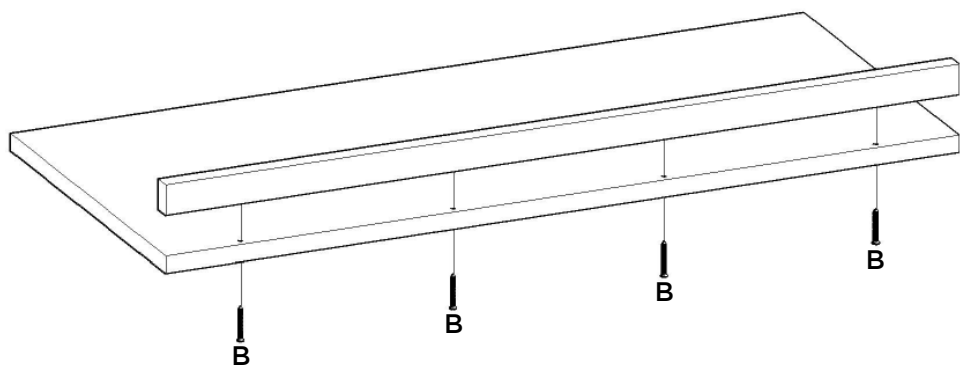

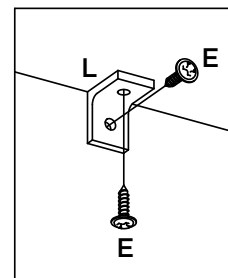
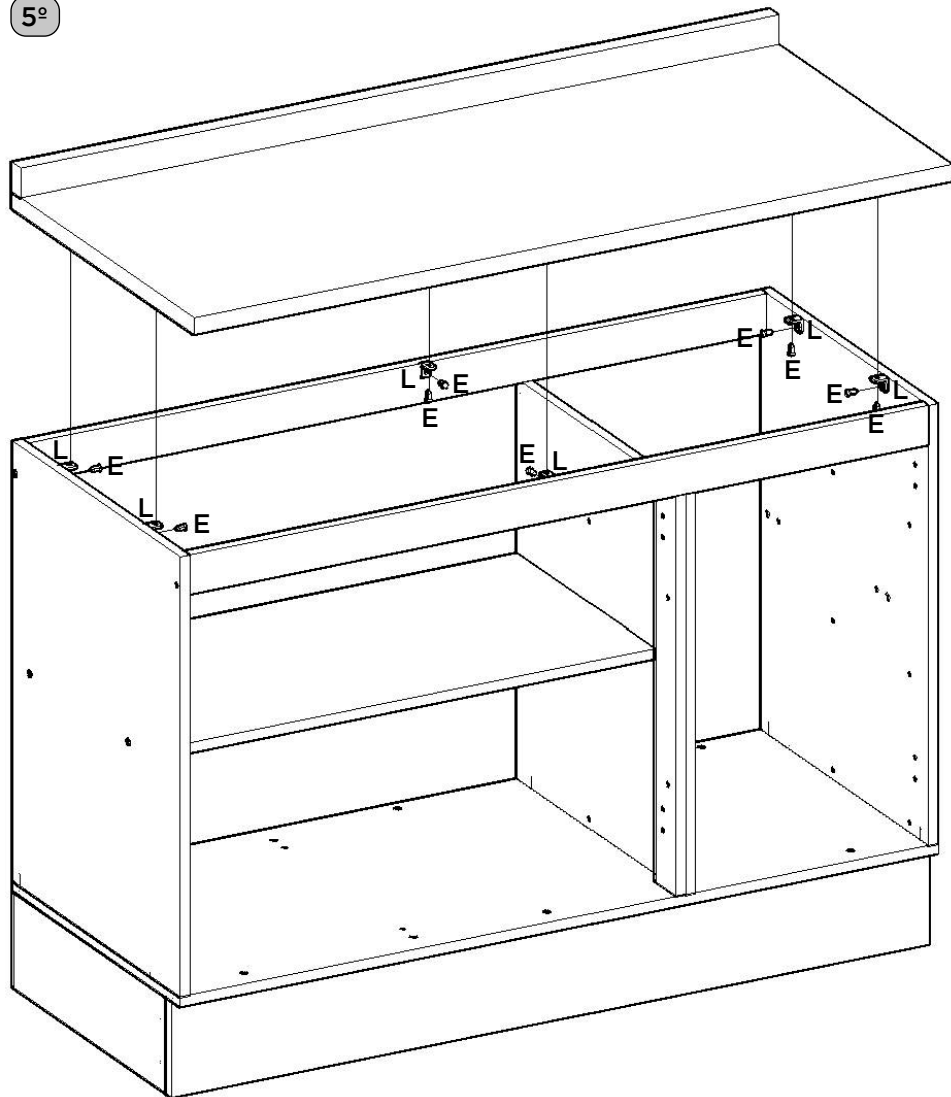

Caso o móvel seja montado com a opção do tampo, fixar o mesmo com 06 cantoneiras (L) e os parafusos 3,5x14mm (E).

Si se monta el auricular con la opción de la cubierta, fijarlo con Los ángulos 06 (L) y 3,5 x14mm tornillos (E).

If the furniture is to be installed with the top cover option, fix it with 06 (L) and 3.5x14mm screws (E).

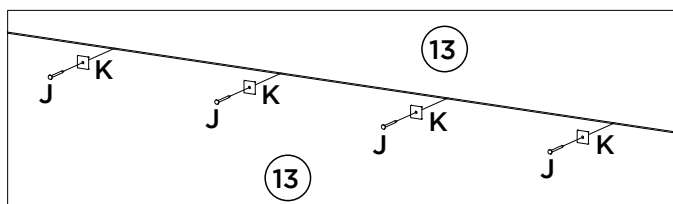
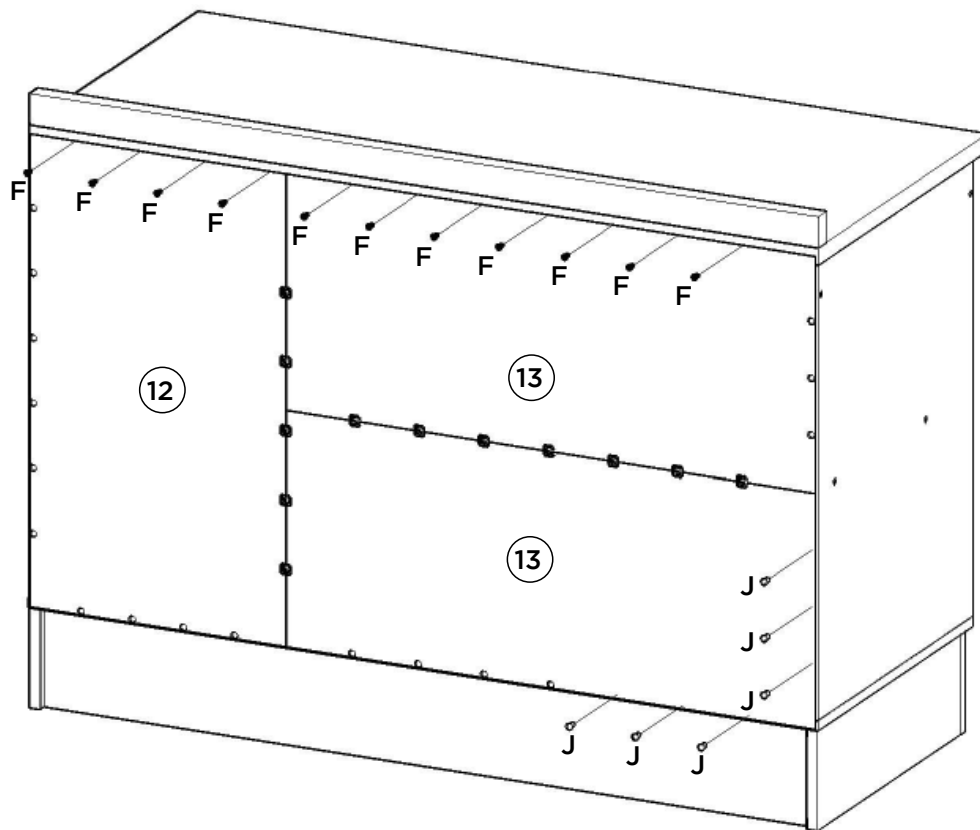
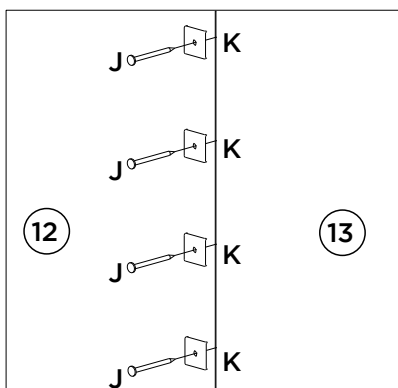

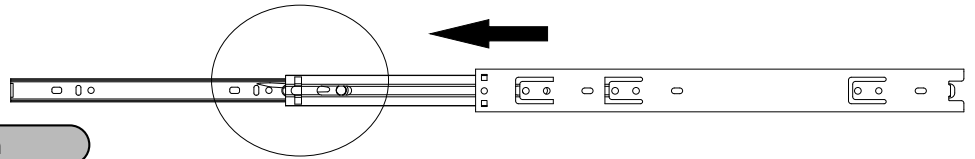
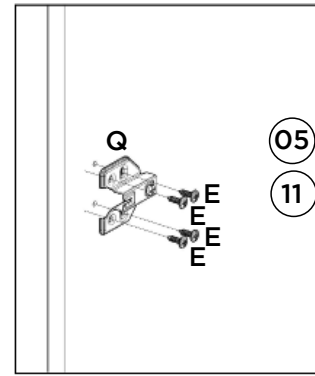
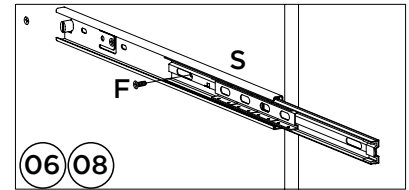
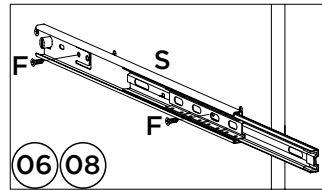
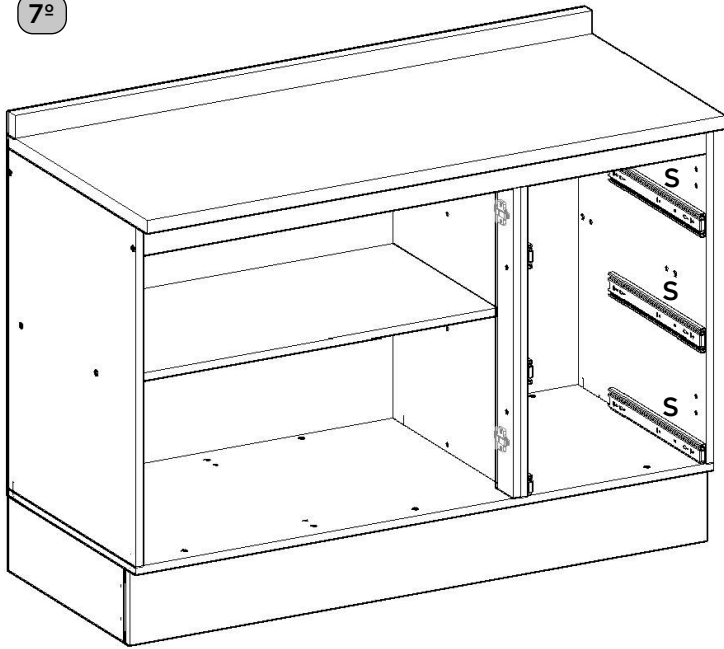

Vídeo: Dicas para fixar a Corrediça

Video: Consejos para arreglar la diapositiva

Video: Tips for Fixing the Slide

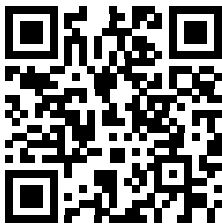

Para a desmontagem da corrediça siga a instrução ao lado.

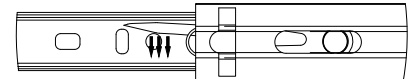

Para el desmontaje seguimiento de diapositivas la instrucción siguiente a.

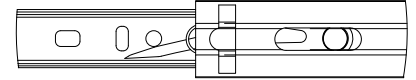

Fixar as corrediças nessas furações
Fijar las diapositivas de estos agujeros

Opção Suspensa

Opción suspendida

Suspended Option

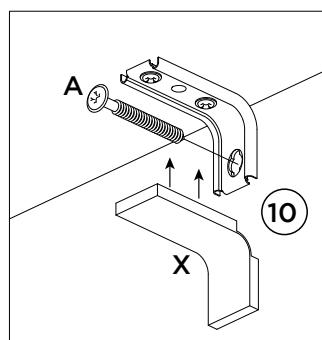
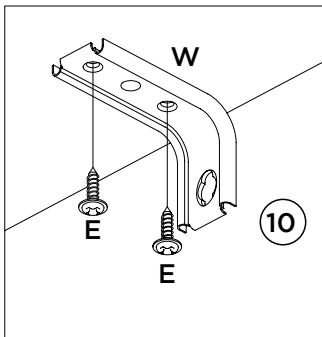

Parede
pared
Wall

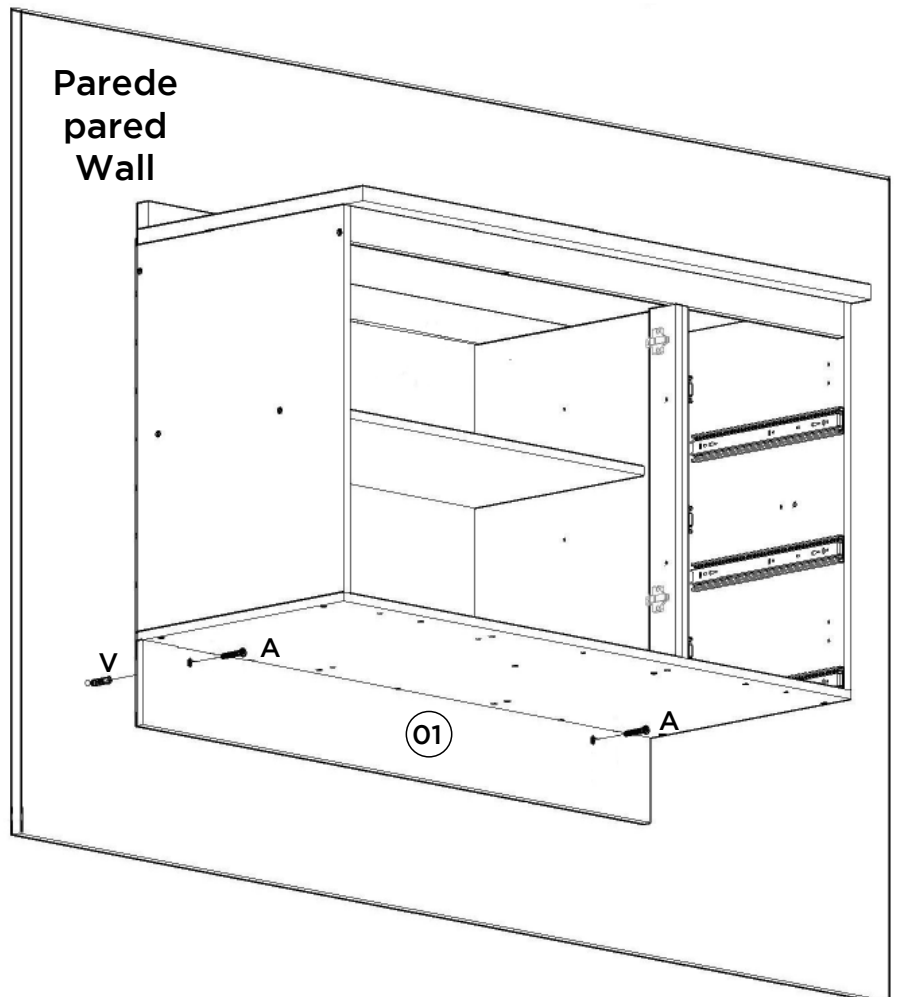

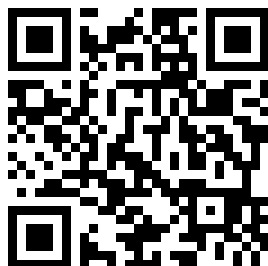
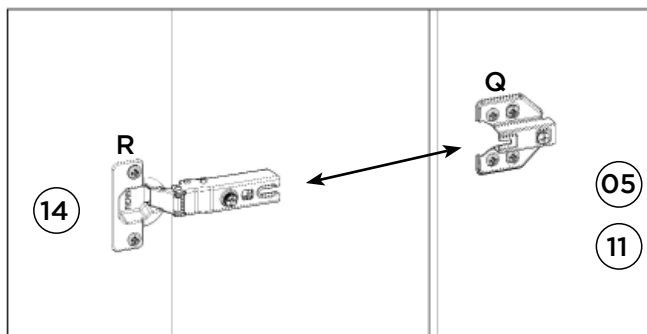
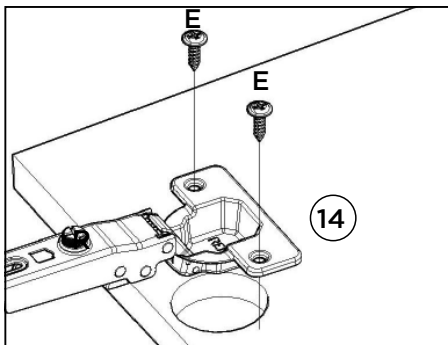

Vídeo: Instalar e regular Dobradiças

Video: Instale y ajuste las bisagras

Video: Install and adjust hinges

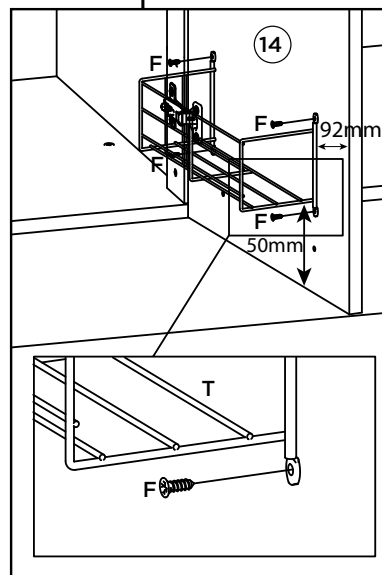
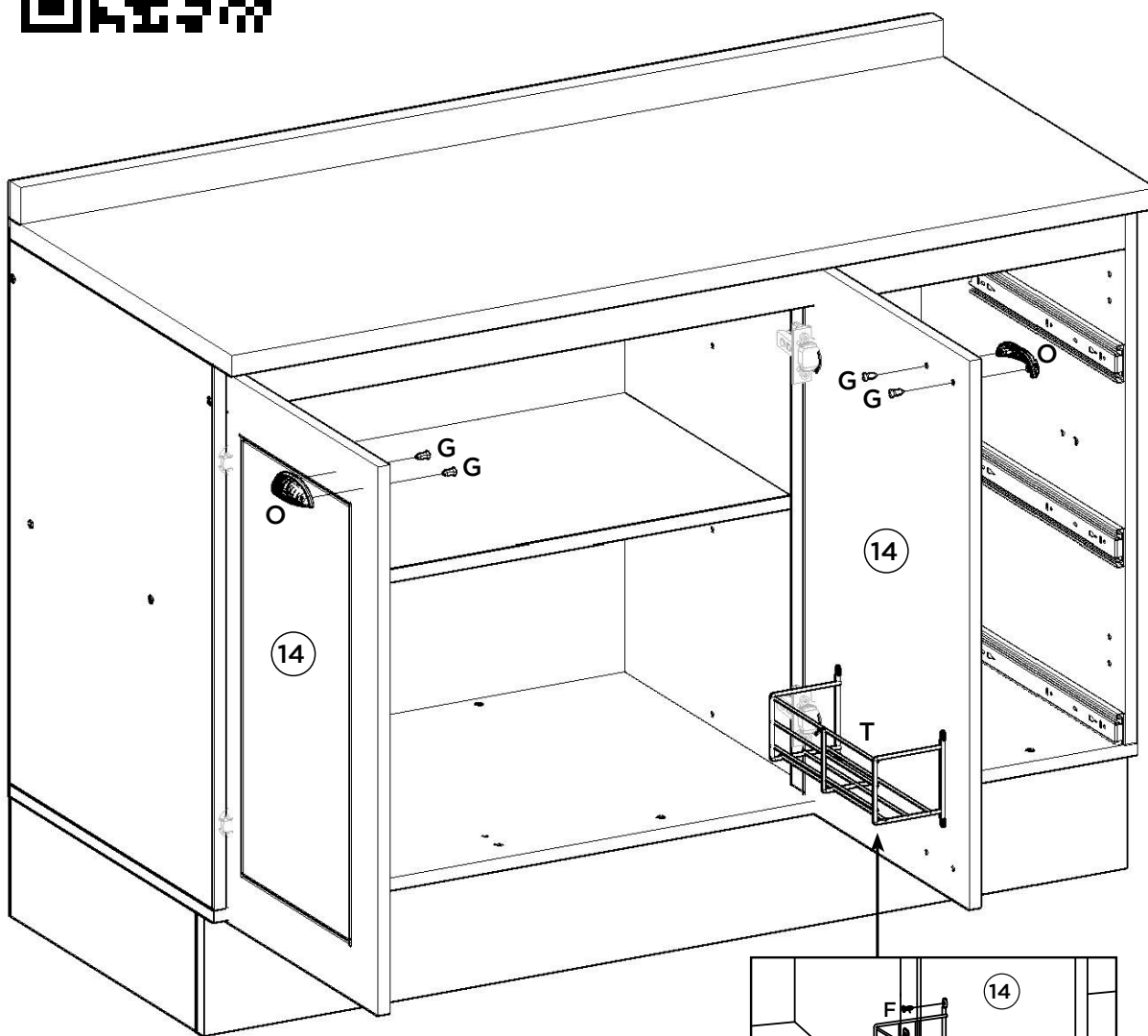

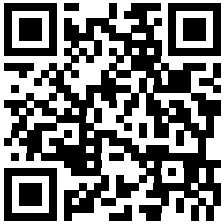
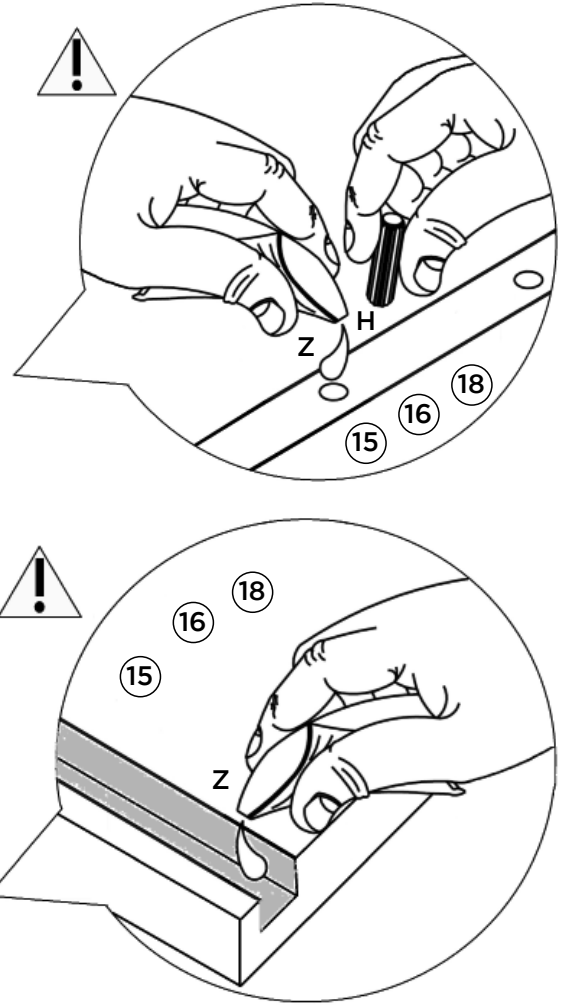
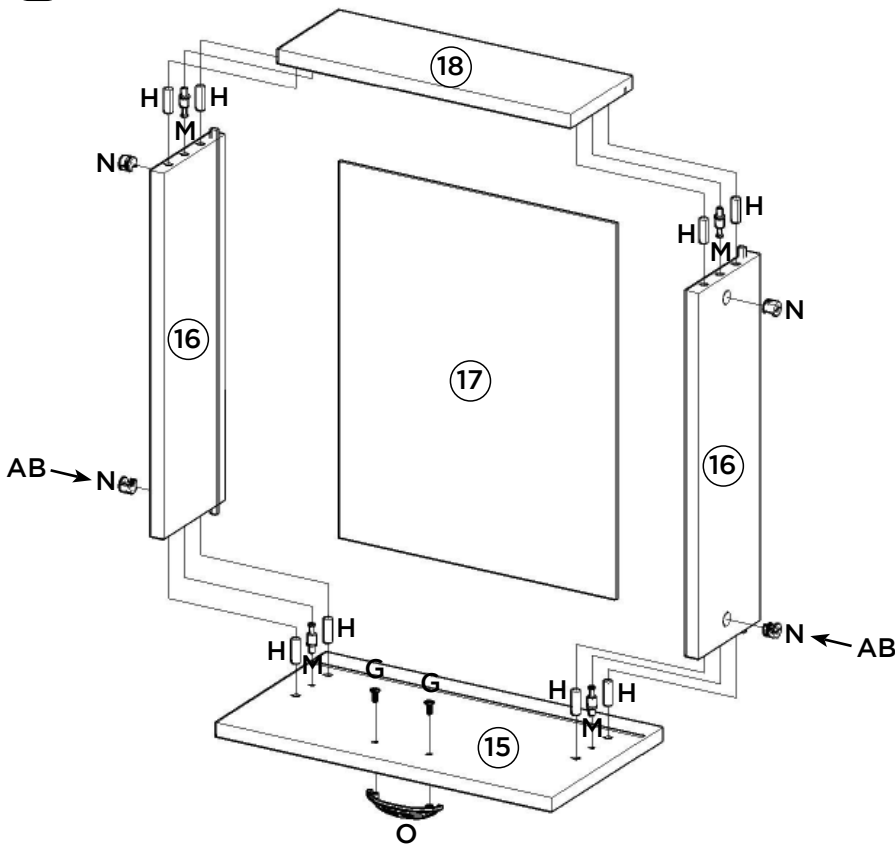

- Vídeo: Dicas para fixar o Minifix
- Video: Consejos para arreglar Minifix
- Video: Tips for Fixing Minifix

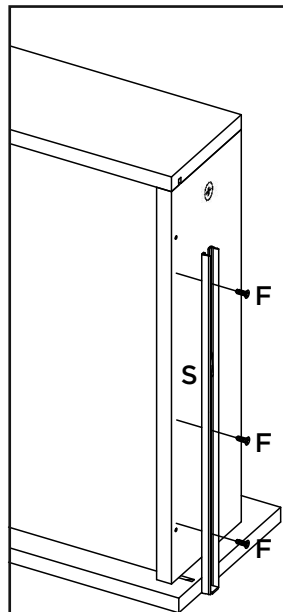
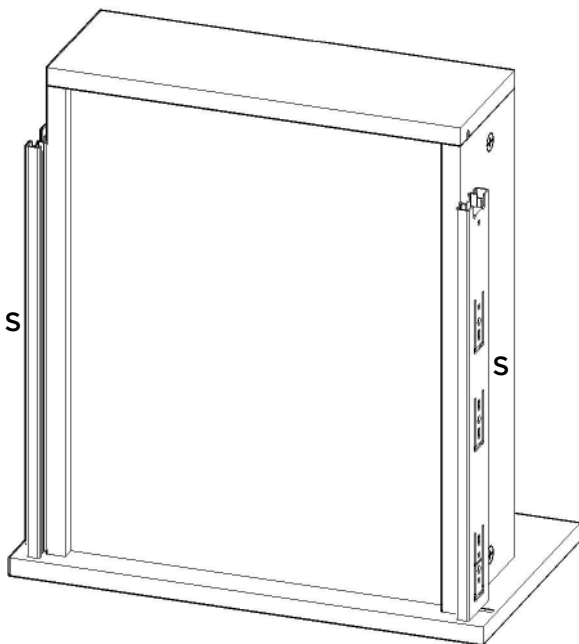

A corredeira (S) deverá ser alinhada com a parte de baixo do lado de gaveta (16).











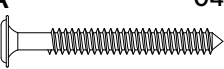







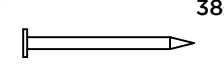



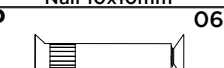

La carcasa (S) será alineada con la parte de por el lado del cajón (16).

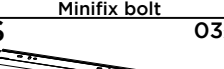
The slide (S) should be aligned with the underside of the drawer side (16).

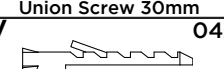
Lista de Peças | Lista de piezas | List of parts

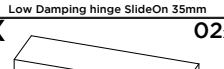
Item	Caixa Caja Box	Qty Ctd Qty	Descrição Descripción Description	Medidas (mm) Dimensions (mm) Size (measurements) (mm)
01	1/1	01	Rodapé Frontal Frente pie de página Front Footer	1200x145x15
02	1/1	02	Rodapé Lateral Pie de página Side Side Footer	450x145x15
03	1/1	01	Rodapé Traseiro Pie de página trasera Rear Footer	1168x145x15
04	1/1	01	Base Base Base	1200x490x15
05	1/1	01	Lateral esquerda Lateral izquierda Left side	660x490x15
06	1/1	01	Divisão División Division	600x490x15
07	1/1	01	Prateleira Estante Shelf	784x400x15
08	1/1	01	Lateral direita Lateral derecha Right side	660x490x15
09	1/1	01	Travessa frontal Travesaño frontal Front crossbar	1169x60x15
10	1/1	01	Travessa traseira Travesaño trasero Rear bumper	1169x60x15
11	1/1	01	Pilastra da Porta Pilastra Puerta Pilaster door	599x60x15
12	1/1	01	Fundo Lateral Fondo Lateral Lateral Background	683x389x3
13	1/1	02	Fundo Fondo Bottom	803x341x3
14	1/1	02	Porta Puerta Door	665x396x15
15	1/1	03	Frente de gaveta Frente de cajón Front of drawer	396x220x15
16	1/1	06	Lado de Gaveta Lado del cajón Drawer Side	400x122x15
17	1/1	03	Fundo de gaveta Fondo de cajón Bottom of drawer	411x326x3
18	1/1	03	Ripa de trás Malla detrás Rear lath	345x122x15

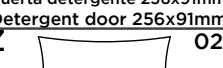
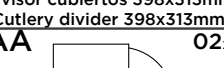
Ferragens | Herrajes | Hardware

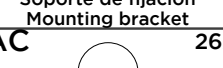
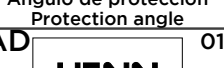
A  Parafuso 5,0x50mm FLA. Tornillo 5,0x50mm FLA. Screw 5,0x50mm FLA.	B  Parafuso 4,5x50mm CHT. Tornillo 4,5x50mm CHT. Screw 4,5x50mm CHT.	C  Parafuso 4,0x25mm CHT. Tornillo 4,0x25mm CHT. Screw 4,0x25mm CHT.	D  Parafuso 3,5x40mm CHT. Tornillo 3,5x40mm CHT. Screw 3,5x40mm CHT.	E  Parafuso 3,5x14mm FLA. Tornillo 3,5x14mm FLA. Screw 3,5x14mm FLA.	F  Parafuso 3,5x12mm CHT. Tornillo 3,5x12mm CHT. Screw 3,5x12mm CHT.
G  Parafuso M4x20mm CHT. ZB Tornillo M4x20mm CHT. ZB Screw M4x20mm CHT. ZB	H  Cavilha 8x25mm Cinta 8x25mm Dowel 8x25mm	I  Prego 12x12mm Anelado Clavo 12x12mm Anillado Ringed Nails 12x12mm	J  Prego 10x10mm Clavo 10x10mm Nail 10x10mm	K  Fixador de fundos Fijador de fondos Bottom fixer	L  Cantoneira plástica Cantenera plástica Plastic angle brackets
M  Parafuso minifix Tornillo minifix Minifix bolt	N  Tambor minifix Tambor minifix Minifix drum	O  Puxador Concha Tirador Concha Shell Handle	P  Parafuso União 30mm Tornillo Unión 30mm Union Screw 30mm	Q  Calço Removível Calzado extraíble Removable Shim	R  Dobradiça SlideOn Baixa Amortecimento 35mm Bisagra SlideOn Baja Amortiguación 35mm Low Damping hinge SlideOn 35mm
S  Corrediça telescópica Diapositivas telescópicas Telescopic slides	T  Porta detergente 256x91mm Puerta detergente 256x91mm Detergent door 256x91mm	U  Divisor talheres 398x313mm Divisor cubiertos 398x313mm Cutlery divider 398x313mm	V  Bucha plástica 8mm Bucha de plástico 8mm 8mm plastic bushing	W  Suporte de fixação Soporte de fijación Mounting bracket	X  Proteção para cantoneira Ángulo de protección Protection angle
Y  Sapata "L" 16x20mm Zapata "L" 16x20mm "L" shoe 16x20mm	Z  Sachê de cola Bolsa de pegamento Glue bag	AA  Giz de correção Tiza de corrección Chalk of correction	AB  Adesivo tapa parafuso 17mm Adhesivo tapón de tornillo 17mm Bolt cover adhesive 17mm	AC  Adesivo tapa parafuso 10mm Adhesivo tapón de tornillo 10mm Bolt cover adhesive 10mm	AD  HENN Etiqueta resinada Henn Etiqueta resinada Henn Henn resin label



O parafuso (P) deve ser usada somente quando este módulo for acoplado a outro módulo componível Henn.

RECOMENDAÇÃO

Para fixar o móvel na parede usar o suporte de fixação (W), o parafuso 3,5x14mm FLA (E), a Bucha 8mm (V) e o parafuso 5,0x50mm FLA (A).

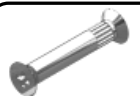

El tornillo (P) se debe utilizar sólo cuando el módulo está conectado a otro módulo componible Henn.

RECOMENDACIÓN

Para conectar el móvil a la pared con el soporte (W), tornillo 3,5 x14mm FLA (E), el casquillo de 8 mm (V) y el 5,0 x50mm tornillo FLA (A).



The screw (P) should be used only when this module is attached to another Henn modular module.

RECOMMENDATION

To fix the furniture to the wall use the mounting bracket (W), the 3.5x14mm FLA (E) screw, the 8mm bushing (V) and the 5.0x50mm FLA screw (A).

HENN

Ind. e Com. de Móveis Henn
Mondai - SC - Brasil

+55 49 3674.3500

@f@moveishenn
www.henn.com.br

INSTRUÇÕES DE MONTAGEM

INSTRUCCIONES DE MONTAJE
ASSEMBLY INSTRUCTIONS

Aéreo 01 Porta Basculante 800mm Americana | Aéreo 01 Puerta Basculante 800mm Americana | 01 air port Tipper 800mm Americana

c C354-05 Branco HP

c C354-131 Cinza

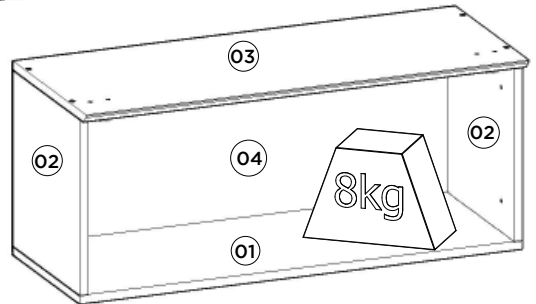
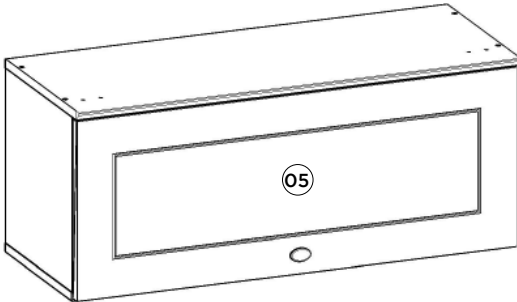

Pesos máximos recomendados
com carga distribuída
Peso máximo recomendado com
a carga distribuída
Recommended maximum weight
with distributed load.

Requisitos para montagem
Requisitos para la montaje
Assembly Requirements

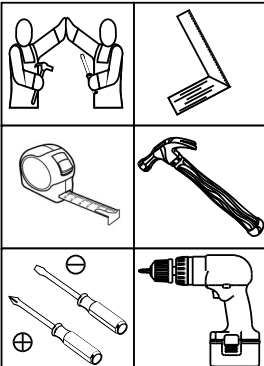

Imagens meramente ilustrativas
Imágenes meramente ilustrativas
Images for illustration only

AVISO

Para limpeza de seu móvel, use uma flanela seca ou umedecida, e não utilize produtos químicos que possam danificar seu produto.

SISTEMA DE MONTAGEM

O sistema de montagem dos produtos, funciona de acordo com a ordem crescente dos números indicados no desenho. Ex: 01, 02, 03, 04... até a conclusão da montagem.

ASSISTÊNCIA TÉCNICA

Para solicitação de Assistência Técnica você consumidor deverá entrar em contato com o Lojista o qual você realizou a compra deste produto e solicitar a assistência técnica das peças avariadas. A garantia abrange todas as peças, partes e componentes que eventualmente venham apresentar defeito de fabricação no prazo de 03 (três) meses, contando a partir da entrega do produto ao consumidor, mediante nota fiscal de compra. Se houver qualquer alteração na estrutura do produto ou ocorrer defeito por negligência do montador/consumidor em relação a instrução de montagem e manuseio, não será fornecido assistência técnica gratuita.

ADVERTENCIA

Para limpeza de su móvil, use una flanela seca o húmeda, y no utilice productos químicos que puedan dañar su producto.

SISTEMA DE MONTAJE

El sistema de montaje de los productos funciona de acuerdo con el orden creciente de los números indicados en el dibujo. Ej: 01, 02, 03, 04... hasta la conclusión del montaje.

ASISTENCIA TÉCNICA

Para solicitar Asistencia Técnica, el consumidor debe comunicarse con el Comercio que usted realizó la compra de este producto y solicita asistencia técnica para las partes dañadas. La garantía cubre todas las partes, piezas y componentes que eventualmente puedan presentar defecto de fabricación en el plazo de 03 (tres) meses, contados a partir de la entrega del producto al consumidor, mediante factura de compra. Si se produce algún cambio en la estructura del producto o se produce un defecto por negligencia del montador/consumidor en relación con las instrucciones de montaje y manipulación, no se prestará asistencia técnica gratuita.

NOTICE

To clean your furniture, use a dry or wet cloth, and do not use chemicals that may damage your product.

ASSEMBLY SYSTEM

The products' assembly system works according to the increasing order of the indicated numbers. For example: 01, 02, 03, 04 ... to the end of the assembly.

TECHNICAL ASSISTANCE

To request Technical Assistance, the consumer must contact the retailer from whom you purchased this product and request technical assistance for the damaged parts. The warranty covers all parts, parts and components that may eventually present a manufacturing defect within a period of 03 (three) months, counting from the delivery of the product to the consumer, by means of a purchase invoice. If there is any change in the structure of the product or defect occurs due to negligence of the assembler/consumer in relation to the assembly and handling instruction, free technical assistance will not be provided.

1º

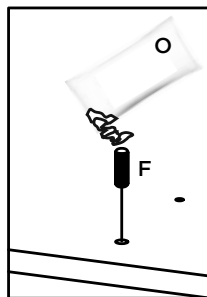
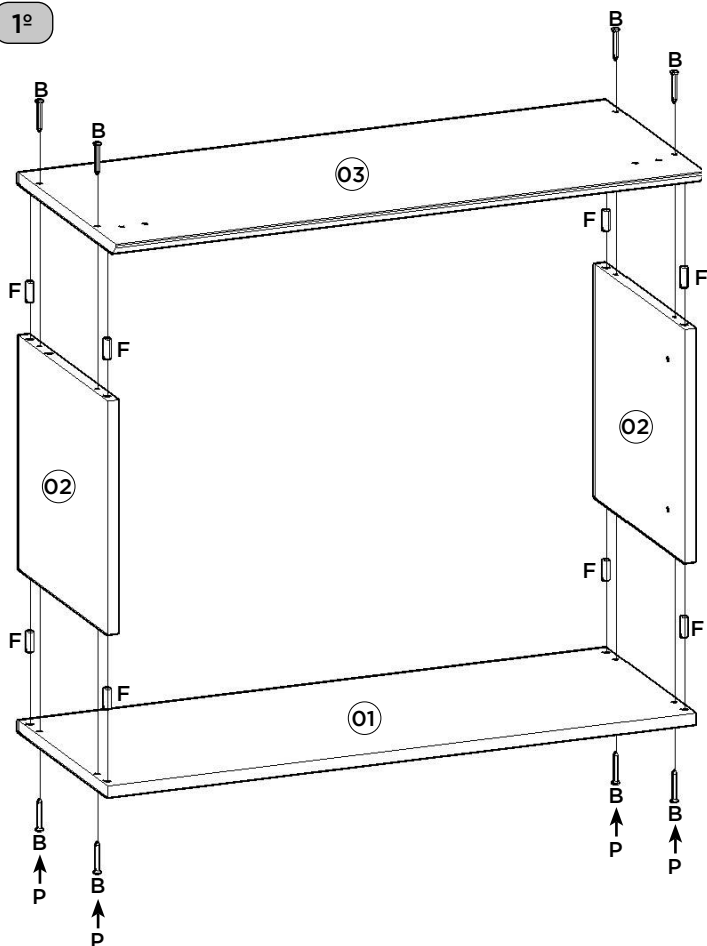

Utilizar o sachê de cola (O) em todas as cavilhas (F) do produto.

Con el pegamento sobre (O) en todos los pernos (F) producto.

Use the glue sachet (O) on all the pegs (F) of the product.

2º

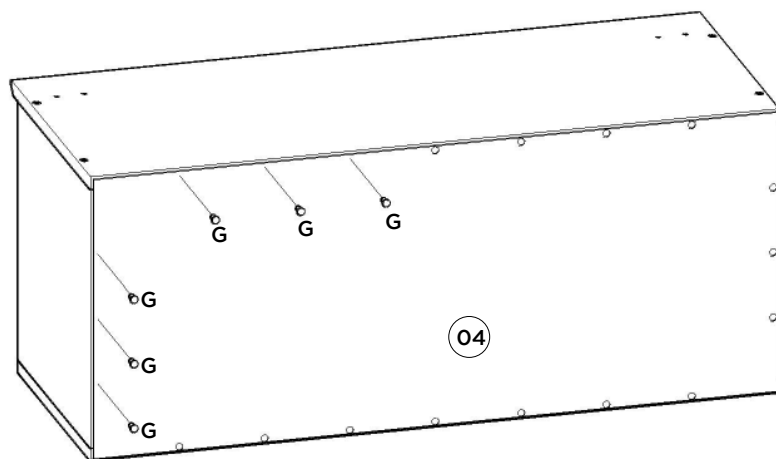

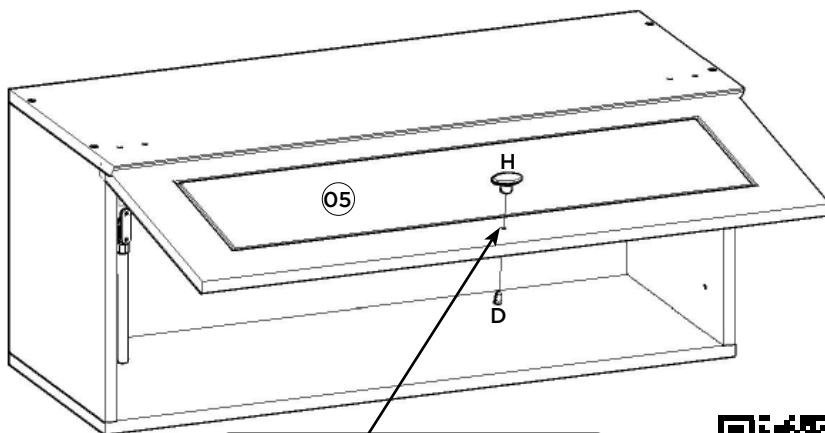

Para colocação do puxador, é necessário fazer a furação passante, com broca de 5mm.

Para colocar el mango, es necesario perforar con un taladro de 5 mm.

For placing the handle, it is necessary to drill through with a 5mm drill.



Video: Instalar e regular Dobradiças

Video: Instale y ajuste las bisagras

Video: Install and adjust hinges

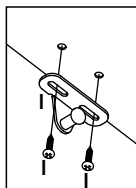
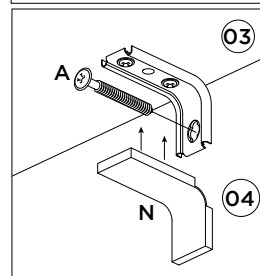
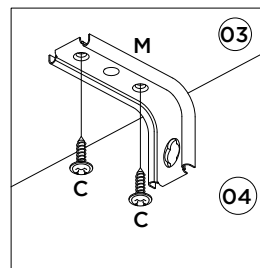
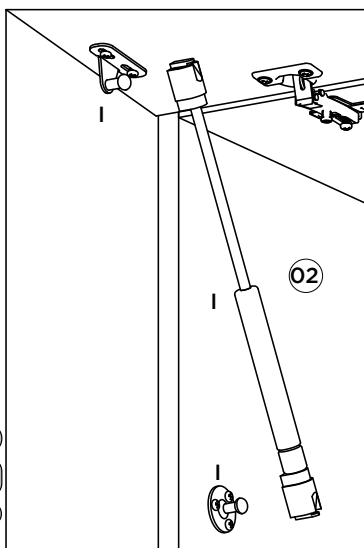
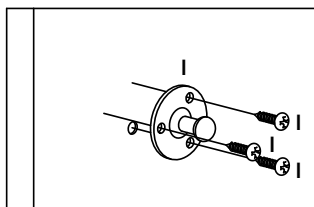
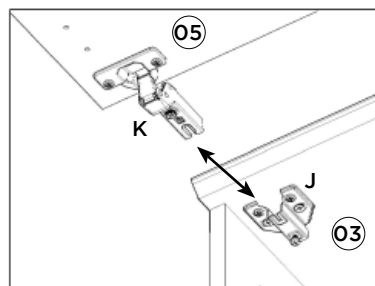
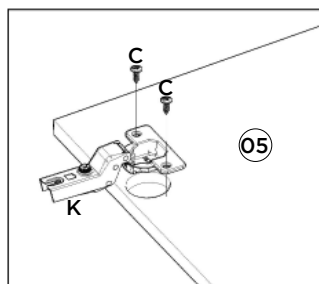
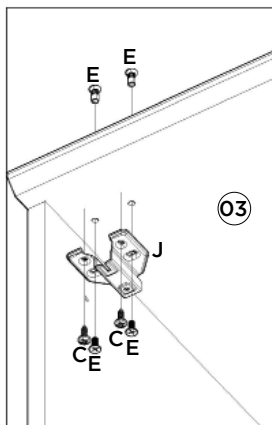

Video: Dicas para instalar o Kit Pistão à Gás













Video: Consejos para instalar el kit de pistón de gas

Video: Tips for installing the Gas Piston Kit

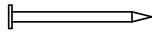
Lista de Peças | Lista de piezas | List of parts

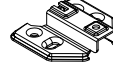
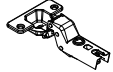
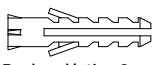
Item	Caixa Caja Box	Qty Ctd Qty	Descrição Descripción Description	Medidas (mm) Dimensions (mm) Size (measurements) (mm)
01	1/1	01	Base Base Base	800x295x15
02	1/1	02	Lateral Direita Esquerda Lateral Derecha Izquierda Right Side Left	307x295x15
03	1/1	01	Tampo Tapa Top	800x322x15
04	1/1	01	Fundo Fondo Bottom	793x331x3
05	1/1	01	Porta Basculante Puerta Basculante Basculating Door	796x315x15

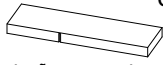
Ferragens | Herrajes | Hardware

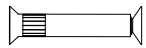
A  Parafuso 5,0x50mm FLA. Tornillo 5,0x50mm FLA. Screw 5,0x50mm FLA.	02x	B  Parafuso 3,5x40mm CHT. Tornillo 3,5x40mm CHT. Screw 3,5x40mm CHT.	08x	C  Parafuso 3,5x14mm FLA. Tornillo 3,5x14mm FLA. Screw 3,5x14mm FLA.	12x	D  Parafuso M4x20mm CHT. ZB Tornillo M4x20mm CHT. ZB Screw M4x20mm CHT. ZB	01x	E  Parafuso União 15mm Tornillo Unión 15mm Union Screw 15mm	04x
F  Cavilha 8x25mm Cinta 8x25mm Dowel 8x25mm	08x	G  Prego 10x10mm Clavo 10x10mm Nail 10x10mm	20x	H  Puxador Pontual PZ14 Oval Tirador Pontual PZ14 Oval PZ14 Oval Point Knob	01x	I  Kit Pistão a Gás 60N Kit Pistón a Gas 60N 60N Gas Piston Kit	01x	J  Calço Removível Calzado extraíble Removable Shim	02x
K  Dobradica SlideOn Super Alta Amort. 35mm Bisagra Super high amort de Slideon. 35mm Slideon Super High Amort hinge. 35mm	02x	L  Bucha plástica 8mm Bucha de plástico 8mm 8mm plastic bushing	02x	M  Suporte de fixação Soporte de fijación Mounting bracket	02x	N  Proteção para cantoneira Ángulo de protección Protection angle	02x	O  Sachê de cola Bolsa de pegamento Glue bag	01x
P  Adesivo tampa parafuso 10mm Adhesivo tapón de tornillo 10mm Bolt cover adhesive 10mm	08x	Q  Parafuso União 30mm Tornillo Unión 30mm Union Screw 30mm	04x						



O parafuso (Q) deve ser usada somente quando este módulo for acoplado a outro módulo componível Henn.



El tornillo (Q) se debe utilizar sólo cuando el módulo está conectado a otro módulo componible Henn.



The screw (Q) should be used only when this module is attached to another Henn modular module.

RECOMENDAÇÃO

Para fixar o móvel na parede usar o suporte de fixação (M), o parafuso 3,5x14mm FLA (C), a Bucha 8mm (L) e o parafuso 5,0x50mm FLA (A).

RECOMENDACIÓN

Para conectar el móvil a la pared con el soporte (M), tornillo 3,5 x14mm FLA (C), el casquillo de 8 mm (L) y el 5,0 x50mm tornillo FLA (A).

RECOMMENDATION

To fix the furniture to the wall use the fixing bracket (M), the 3.5x14mm FLA (C) screw, the 8mm bushing (L) and the 5.0x50mm FLA screw (A).

HENNInd. e Com. de Móveis Henn
Mondai - SC - Brasil

☎+55 49 3674.3500

📱@moveishenn
www.henn.com.br**INSTRUÇÕES DE MONTAGEM****INSTRUCCIONES DE MONTAJE
ASSEMBLY INSTRUCTIONS****BALCÃO 2 PORTAS 800MM AMERICANA | BALCÓN 2 PUERTAS 800MM AMERICANA |
BALCONY 2 DOORS 800MM AMERICANA****Referência/Cor**

-
- C355-05 Branco HP
-
-
- C355-131 Cinza

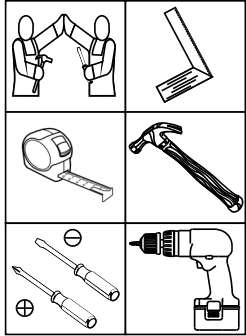
**Requisitos para montagem
Requisitor para la montaje
Assembly Requirements**Imagens meramente ilustrativas
Imágenes meramente ilustrativas
Images for illustration only**OPCIONAL:**

O944-121 Kit Pé Cônico 145mm (vendido separadamente). Caso opte em colocar pé no produto, utilizar as pré-furações que possui na Base e fixá-lo com o Parafuso que consta no Kit.

OPCIONAL:

O944-121 Kit Pie Cónico 145mm (se vende por separado). Si opta por colocar pie en el producto, utilizar las pre-huracuras que tenga en la Base y fijarlo con el Tornillo que consta en el Kit.

OPTIONAL:

O944-121 Tapered Foot Kit 145mm (sold separately). If you choose to put foot in the product, use the pre-drillings in the Base and fix it with the Screw included in the Kit.

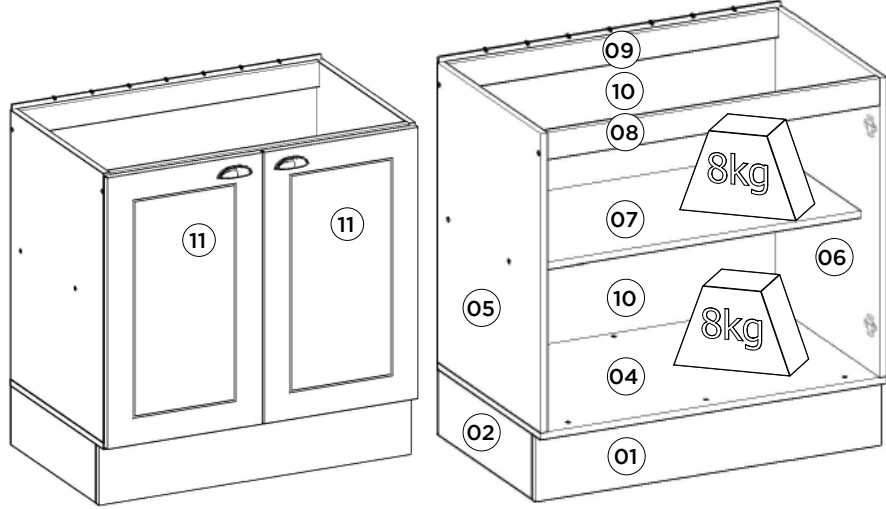
**AVISO**

Para limpeza de seu móvel, use uma flanela seca ou umedecida, e não utilize produtos químicos que possam danificar seu produto.

SISTEMA DE MONTAGEM

O sistema de montagem dos produtos, funciona de acordo com a ordem crescente dos números indicados no desenho. Ex: 01, 02, 03, 04... até a conclusão da montagem.

ASSISTÊNCIA TÉCNICA

Para solicitação de Assistência Técnica você consumidor deverá entrar em contato com o Lojista a qual você realizou a compra deste produto e solicitar a assistência técnica das peças avariadas. A garantia abrange todas as peças, partes e componentes que eventualmente venham apresentar defeito de fabricação no prazo de 03 (três) meses, contando a partir da entrega do produto ao consumidor, mediante nota fiscal de compra. Se houver qualquer alteração na estrutura do produto ou ocorrer defeito por negligência do montador/consumidor em relação a instrução de montagem e manuseio, não será fornecido assistência técnica gratuita.

ADVERTENCIA

Para limpieza de su móvil, use una franela seca o húmeda, y no utilice productos químicos que puedan dañar su producto.

SISTEMA DE MONTAJE

El sistema de montaje de los productos funciona de acuerdo con el orden creciente de los números indicados en el dibujo. Ej: 01, 02, 03, 04... hasta la conclusión del montaje.

ASISTENCIA TÉCNICA

Para solicitar Asistencia Técnica, el consumidor debe comunicarse con el Comercio que usted realizó la compra de este producto y solicita asistencia técnica para las partes dañadas. La garantía cubre todas las partes, piezas y componentes que eventualmente puedan presentar defecto de fabricación en el plazo de 03 (tres) meses, contados a partir de la entrega del producto al consumidor, mediante factura de compra. Si se produce algún cambio en la estructura del producto o se produce un defecto por negligencia del montador/consumidor en relación con las instrucciones de montaje y manipulación, no se preparará asistencia técnica gratuita.

NOTICE

To clean your furniture, use a dry or wet cloth, and do not use chemicals that may damage your product.

ASSEMBLY SYSTEM

The products' assembly system works according to the increasing order of the indicated numbers. For example: 01, 02, 03, 04... to the end of the assembly.

TECHNICAL ASSISTANCE

To request Technical Assistance, the consumer must contact the retailer from whom you purchased this product and request technical assistance for the damaged parts. The warranty covers all parts, parts and components that may eventually present a manufacturing defect within a period of 03 (three) months, counting from the delivery of the product to the consumer, by means of a purchase invoice. If there is any change in the structure of the product or defect occurs due to negligence of the assembler/consumer in relation to the assembly and handling instruction, free technical assistance will not be provided.

**Pesos máximos recomendados com carga distribuída
Peso máximo recomendado con la carga distribuída
Recommended maximum weights with evenly distributed.**

Lista de Peças | Lista de piezas | List of parts

Item	Caixa Caja Box	Qty	Descrição Descripción Description	Medidas (mm) Dimensions (mm) Size (measurements) (mm)
01	1/1	01	Rodapé Frontal Frente pie de página Front Footer	800x145x15
02	1/1	02	Rodapé Lateral Pie de página Side Side Footer	450x145x15
03	1/1	01	Rodapé Traseiro Pie de página trasera Rear Footer	768x145x15
04	1/1	01	Base Base Base	800x490x15
05	1/1	01	Lateral esquerda Lateral izquierda Left side	660x490x15
06	1/1	01	Lateral direita Lateral derecha Right side	660x490x15
07	1/1	01	Prateleira Estante Shelf	769x400x15
08	1/1	01	Travessa frontal Travesaño frontal Front crossbar	769x60x15
09	1/1	01	Travessa traseira Travesaño trasero Rear bumper	769x60x15
10	1/1	02	Fundo Fondo Bottom	792x341x3
11	1/1	02	Porta Puerta Door	665x396x15

Ferragens | Herrajes | Hardware

A 04x	B 03x	C 18x	D 44x	E 07x	F 04x	G 04x	H 24x
Parafuso 5,0x50mm FLA. Tornillo 5,0x50mm FLA. Screw 5,0x50mm FLA.	Parafuso 4,5x50mm CHT. Screw 4,5x50mm CHT.	Parafuso 3,5x40mm CHT. Tornillo 3,5x40mm CHT. Screw 3,5x40mm CHT.	Parafuso 3,5x14mm FLA. Tornillo 3,5x14mm FLA. Screw 3,5x14mm FLA.	Parafuso 3,5x12mm CHT. Tornillo 3,5x12mm CHT. Screw 3,5x12mm CHT.	Parafuso M4x20mm CHT. ZB Tornillo M4x20mm CHT. ZB Screw M4x20mm CHT. ZB	Parafuso União 30mm Tornillo Unión 30mm Union Screw 30mm	Cavilha 8x25mm Cinta 8x25mm Dowel 8x25mm
I 27x	J 07x	K 08x	L 02x	M 04x	N 04x	O 04x	P 02x
Prego 10x10mm Clavo 10x10mm Nail 10x10mm	Fixador de fundos Fijador de fondos Bottom fixer	Cantoneira plástica Cantenera plástica Plastic angle brackets	Puxador Concha Tirador Concha Shell Handle	Calço Removível Calzado extraíble Removable Shim	Dobradilha SlideOn Baixa Amortecedor 35mm Bisagra SlideOn Baja Amortiguador 35mm Low SlideOn Hinge 35mm Shock Absorber	Bucha plástica 8mm Bucha de plástico 8mm 8mm plastic bushing	Suporte de fixação Soporte de fijación Mounting bracket

O parafuso (G) deve ser usada somente quando este módulo for acoplado a outro módulo componível Henn.

El tornillo (G) se debe utilizar sólo cuando el módulo está conectado a otro módulo componible Henn.

The screw (G) should be used only when this module is attached to another Henn modular module.

RECOMENDAÇÃO

Para fixar o móvel na parede usar o suporte de fixação (P), o parafuso 3,5x14mm FLA (D), a Bucha 8mm (O) e o parafuso 5,0x50mm FLA (A).

RECOMENDACIÓN

Para conectar el móvil a la pared con el soporte (P), tornillo 3,5 x14mm FLA (D), el casquillo de 8 mm (O) y el 5,0 x50mm tornillo FLA (A).

RECOMMENDATION

To fix the furniture to the wall use the mounting bracket (P), the 3.5x14mm FLA (D) screw, the 8mm bushing (O) and the 5.0x50mm FLA screw (A).

Q 02x **R** 02x
Proteção para cantoneira
Ángulo de protección
Protection angle
Giz de correção
Tiza de corrección
Chalk of correction

S 01x **T** 22x
Sachê de cola
Bolsa de pegamento
Glue bag
Adesivo tapa parafuso 10mm
Adhesivo tapón de tornillo 10mm
Bolt cover adhesive 10mm

U 04x **V** 04x
Prego 12x12mm Anelado
Clavo 12x12mm Anillado
Ringed Nails 12x12mm
Sapata "L" 16x20mm
Zapata "L" 16x20mm
"L" shoe 16x20mm

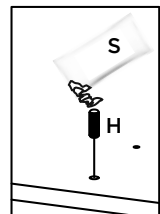
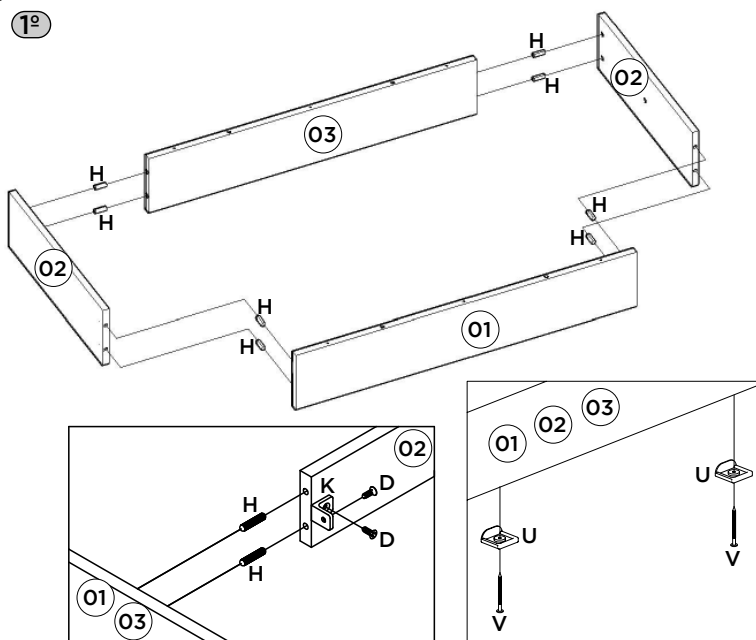

Utilizar o sachê de cola (S) em todas as cavilhas (H) do produto.
 Con el pegamento sobre (S) en todos los pernos (H) producto.
 Use the glue sachet (S) on all the pegs (H) of the product.

2º Esse tampo é opcional e é vendido separadamente (C904-114).
 Esta vez es opcional y se vende por separado (C904-114).
 This top is optional and is sold separately (C904-114).

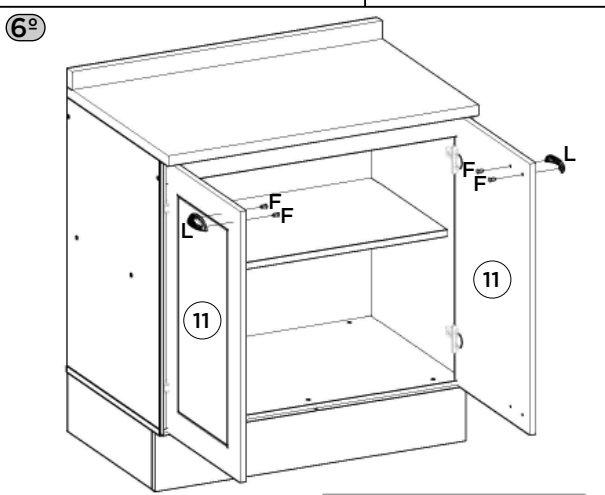
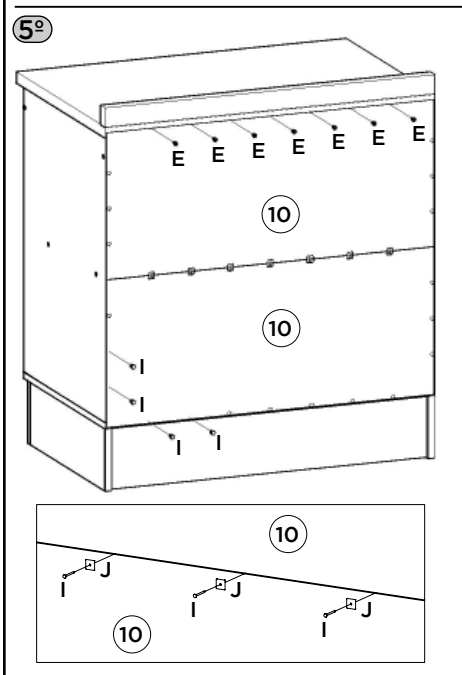
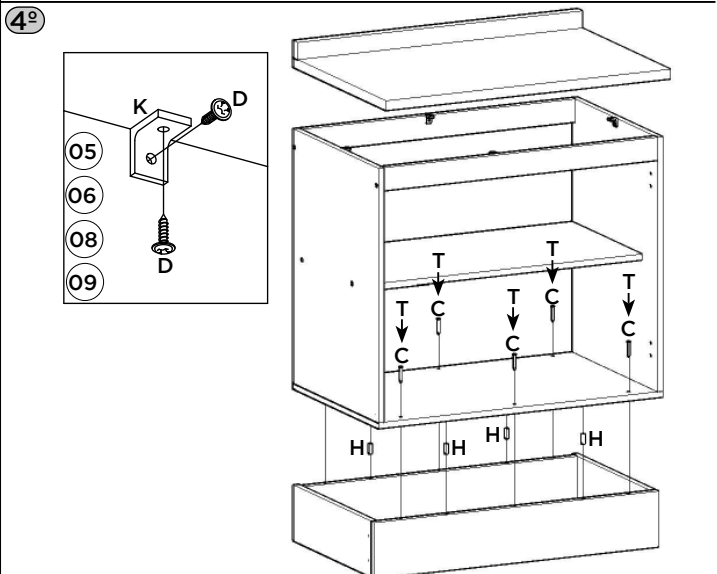
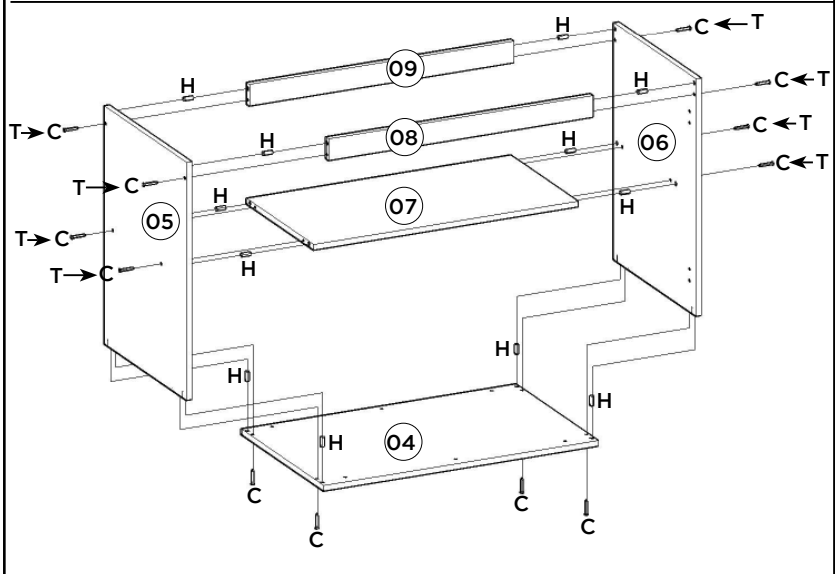
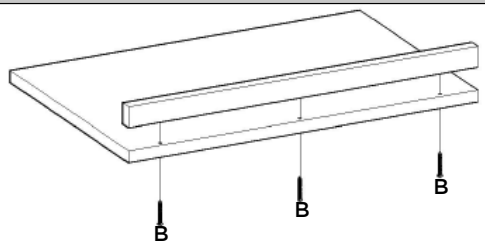

Para colocação dos puxadores, é necessário fazer a furação passante, com Broca de 5mm.
 Para la colocación de las asas, es necesario perforar a través, con una broca de 5mm.
 To place the handles is necessary to make the through hole, drill 5mm.

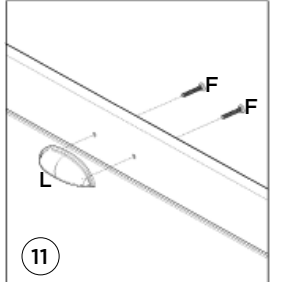

Opção Suspensa
 Opción suspendida
 Suspended Option

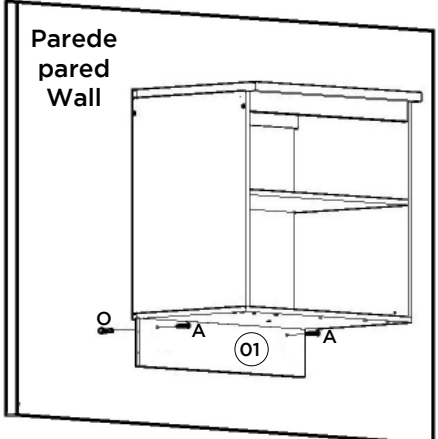
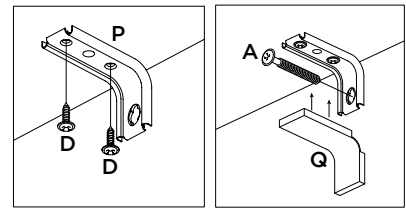

Video: Instalar e regular Dobradiças
 Video: Instale y ajuste las bisagras
 Video: Install and adjust hinges

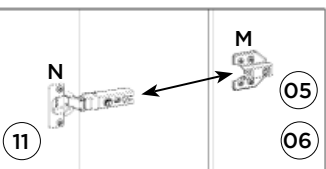
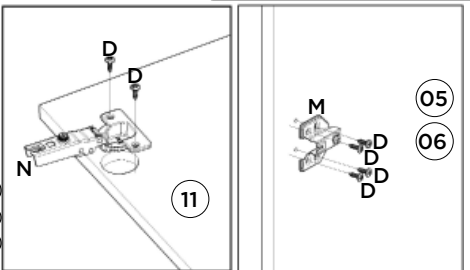



Ind. e Com. de Móveis Henn
Mondai - SC - Brasil

+55 49 3674.3500

@moveishenn
www.henn.com.br

INSTRUÇÕES DE MONTAGEM

INSTRUCCIONES DE MONTAJE
ASSEMBLY INSTRUCTIONS

Aéreo 02 Portas 800mm Americana | Aéreo 02 Puertas 800mm Americana | Aerial 02 doors 800mm Americana

Referência/Cor
c C356-05 Branco HP
c C356-131 Cinza

Requisitos para montagem
Requisitos para la montaje
Assembly Requirements

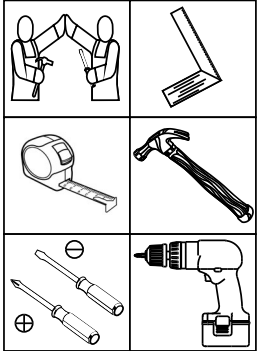

Imagens meramente ilustrativas
Imágenes meramente ilustrativas
Images for illustration only

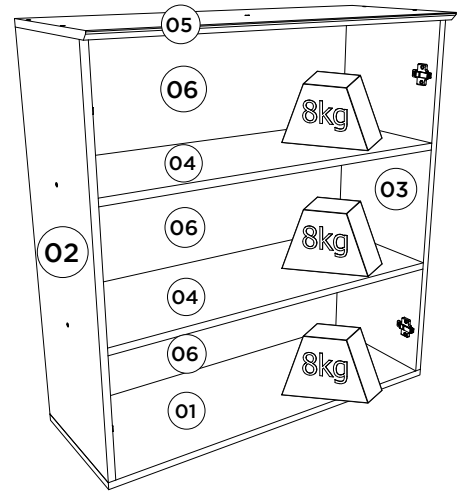
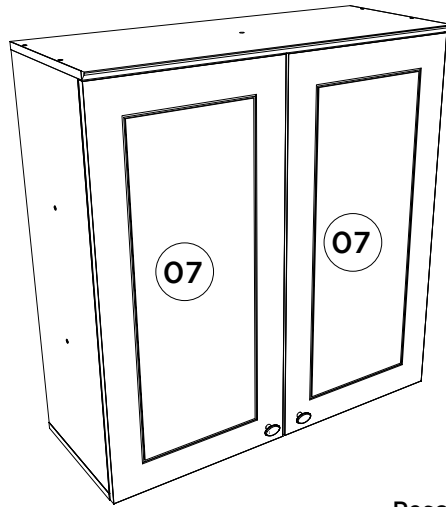

Pesos máximos recomendados com carga distribuída
Peso máximo recomendado con la carga distribuida
Recommended maximum weight with distributed load.

Lista de Peças | Lista de piezas | List of parts

Item	Caixa Caja Box	Qtd Ctd Qty	Descrição Descripción Description	Medidas (mm) Dimensions (mm) Size (measurements) (mm)
01	1/1	01	Base Base Base	800x295x15
02	1/1	01	Lateral esquerda Lateral izquierdo Left side	800x295x15
03	1/1	01	Lateral Direita Lateral Derecha Right side	800x295x15
04	1/1	02	Prateleira Estante Shelf	769x295x15
05	1/1	01	Tampo Tapa Top	800x322x15
06	1/1	03	Fundo Fondo Bottom	792x274x3
07	1/1	02	Porta Puerta Door	813x396x15

Ferragens | Herrajes | Hardware

A Parafuso 5,0x50mm FLA. Tornillo 5,0x50mm FLA. Screw 5,0x50mm FLA.	B Parafuso 3,5x40mm CHT. Tornillo 3,5x40mm CHT. Screw 3,5x40mm CHT.	C Parafuso 3,5x14mm FLA. Tornillo 3,5x14mm FLA. Screw 3,5x14mm FLA.	D Parafuso M4x20mm CHT. ZB Tornillo M4x20mm CHT. ZB Screw M4x20mm CHT. ZB	E Cavilha 8x25mm Cinta 8x25mm Dowel 8x25mm	F Calço Removível Calzado extraíble Removable Shim
G Dobradiça SlideOn Baixa Amortecedor 35mm Bisagra SlideOn Baja Amortiguador 35mm Low SlideOn Hinge 35mm Shock Absorber	H Puxador Pontual PZ14 Oval Tirador Puntual PZ14 Oval PZ14 Oval Point Knob	I Bucha plástica 8mm Bucha de plástico 8mm 8mm plastic bushing	J Suporte de fixação Soporte de fijación Mounting bracket	K Proteção para cantoneira Ángulo de protección Protection angle	L Parafuso União 30mm Tornillo Unión 30mm Union Screw 30mm
M Giz de correção Tiza de corrección Chalk of correction	N Sachê de cola Bolsa de pegamento Glue bag	O Adesivo tapa parafuso 10mm Adhesivo tapón de tornillo 10mm Bolt cover adhesive 10mm	P Fixador de fundos Fijador de fondos Bottom fixer	Q Prego 10x10mm Clavo 10x10mm Nail 10x10mm	R Etiqueta resinada Henn Etiqueta resinada Henn Henn resin label

O parafuso (L) deve ser usada somente quando este módulo for acoplado a outro módulo componível Henn.

El tornillo (L) se debe utilizar sólo cuando el módulo está conectado a otro módulo componible Henn.

The screw (L) should be used only when this module is attached to another Henn modular module.

RECOMENDAÇÃO
Para fixar o móvel na parede usar o suporte de fixação (J), o parafuso 3,5x14mm FLA (C), a Bucha 8mm (I) e o parafuso 5,0x50mm FLA (A).

RECOMENDACIÓN
Para conectar el móvil a la pared con el soporte (J), tornillo 3,5 x14mm FLA (C), el casquillo de 8 mm (I) y el 5,0 x50mm tornillo FLA (A).

RECOMMENDATION
To fix the furniture to the wall use the fixing bracket (J), the 3.5x14mm FLA (C) screw, the 8mm bushing (I) and the 5.0x50mm FLA screw (A).

1

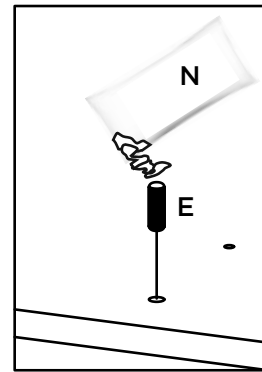
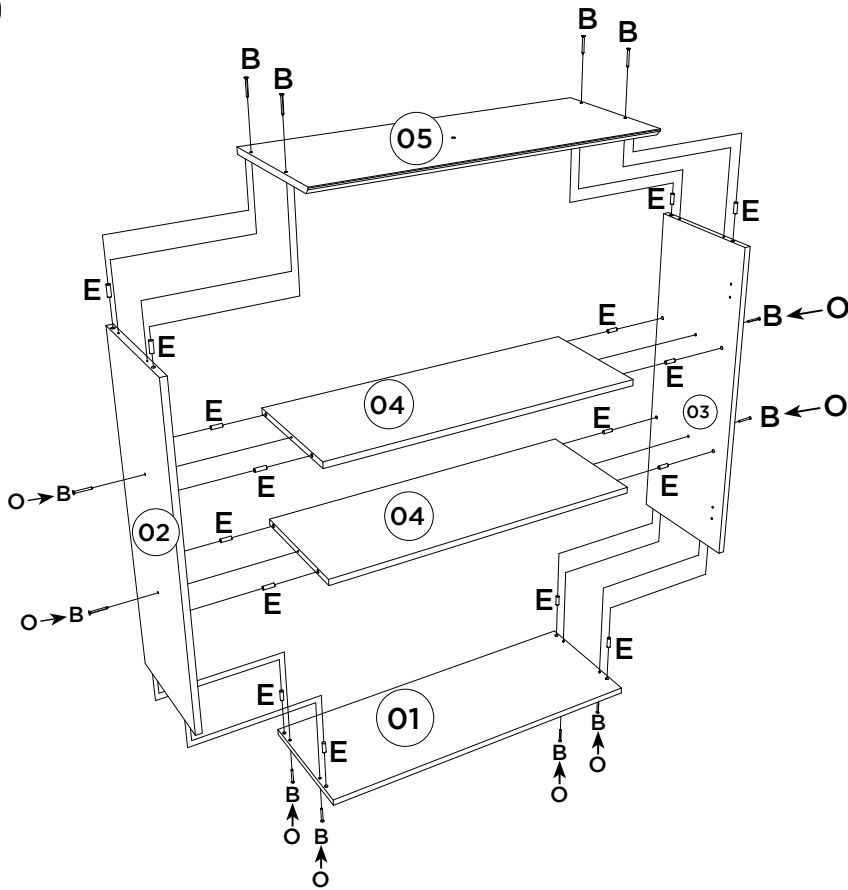

Utilizar o sachê de cola (N) em todas as cavilhas (E) do produto.

Con el pegamento sobre (N) en todos los pernos (E) producto.

Use the glue sachet (N) on all the pegs (E) of the product.

AVISO

Para limpeza de seu móvel, use uma flanela seca ou umedecida, e não utilize produtos químicos que possam danificar seu produto.

SISTEMA DE MONTAGEM

O sistema de montagem dos produtos, funciona de acordo com a ordem crescente dos números indicados no desenho. Ex: 01, 02, 03, 04... até a conclusão da montagem.

ADVERTENCIA

Para limpeza de su móvil, use una flanela seca o húmeda, y no utilice productos químicos que puedan dañar su producto.

SISTEMA DE MONTAJE

El sistema de montaje de los productos funciona de acuerdo con el orden creciente de los números indicados en el dibujo. Ej.: 01, 02, 03, 04... hasta la conclusión del montaje.

NOTICE

To clean your furniture, use a dry or wet cloth, and do not use chemicals that may damage your product.

2

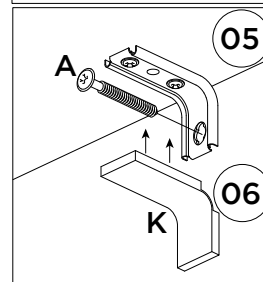
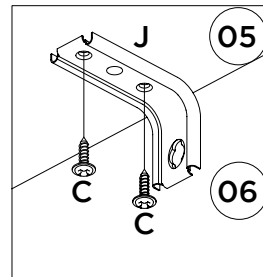
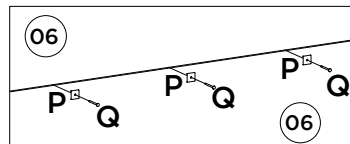
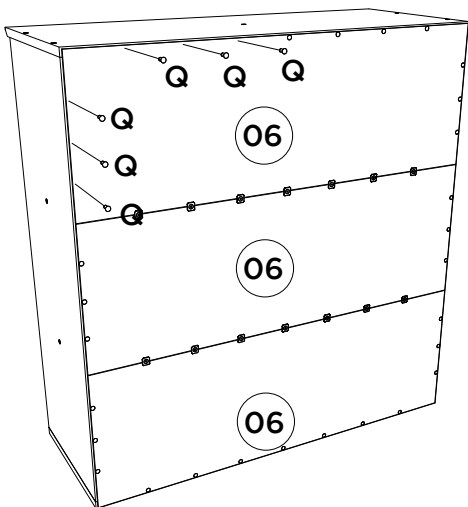

3

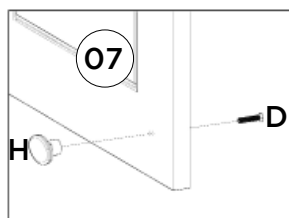
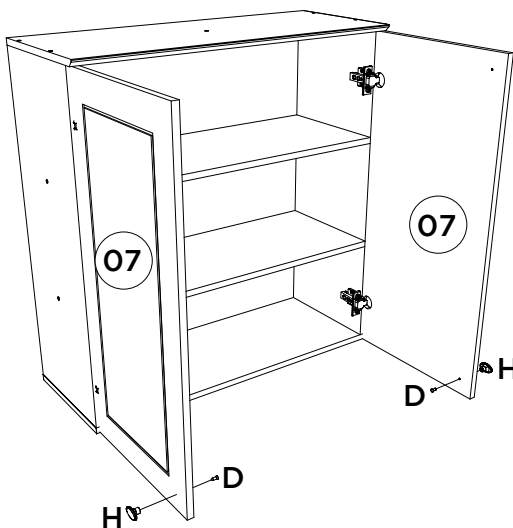

Para colocação dos puxadores, é necessário fazer a furação passante, com Broca de 5mm.

Para la colocación de las asas, es necesario perforar a través, con una broca de 5mm.

To place the handles is necessary to make the through hole, drill 5mm.

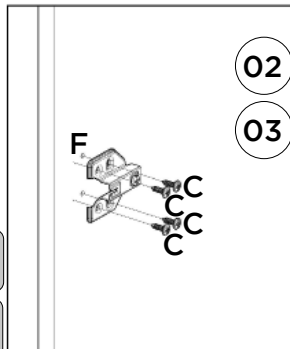

Video: Instalar e regular Dobradiças

Video: Instale y ajuste las bisagras

Video: Install and adjust hinges

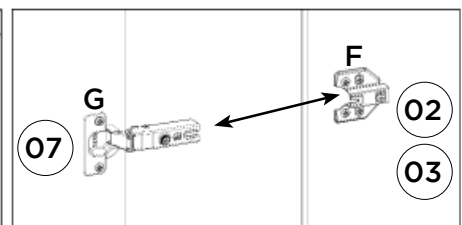
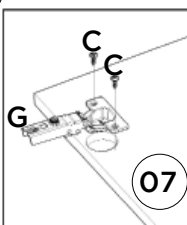

HENNInd. e Com. de Móveis Henn
Mondai - SC - Brasil

+55 49 3674.3500

@moveishenn
www.henn.com.br**INSTRUÇÕES DE MONTAGEM****INSTRUCCIONES DE MONTAJE
ASSEMBLY INSTRUCTIONS****Balcão Canto Reto 01 Porta Americana | Balcón de esquina Reto 01 Puerto Americana |
Balcony Corner Straight 01 Door Americana****Referência/Cor**

-
- C361-05 Branco HP
-
-
- C361-131 Cinza

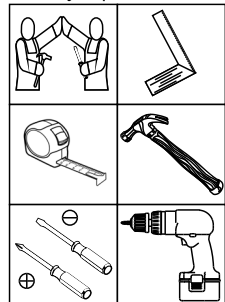
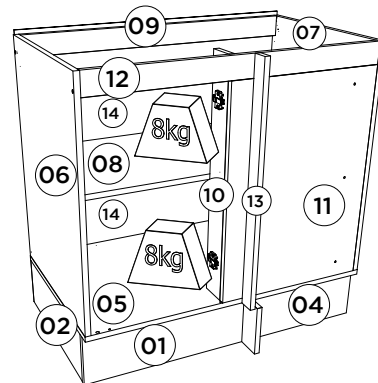
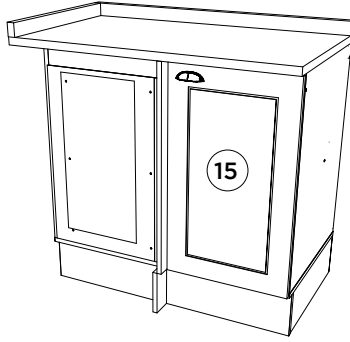
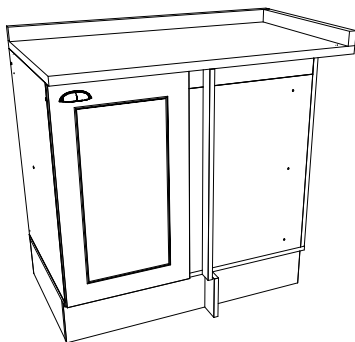
Opção 1
Opción 1
Option 1Opção 2
Opción 2
Option 2**Requisitos para montagem
Requisitor para la montaje
Assembly Requirements**Imagens meramente ilustrativas
Imágenes meramente ilustrativas
Images for illustration only

**Pesos máximos recomendados com carga distribuída
Peso máximo recomendado con la carga distribuida
Recommended maximum weights with evenly distributed.**

Lista de Peças | Lista de piezas | List of parts

Item	Caixa Caja Box	Qtd Ctd Qty	Descrição Descripción Description	Medidas (mm) Dimensions (mm) Size (measurements) (mm)
01	1/1	01	Rodapé Frontal Frente pie de página Front Footer	840x145x15
02	1/1	02	Rodapé Lateral Pie de página Side Side Footer	450x145x15
03	1/1	01	Rodapé Traseiro Pie de página trasera Rear Footer	808x145x15
04	1/1	01	Rodapé fechamento Pie de página de cierre Closing footer	145x68x15
05	1/1	01	Base Base Base	840x490x15
06	1/1	01	Lateral esquerda Lateral izquierda Left side	660x490x15
07	1/1	01	Lateral direita Lateral derecha Right side	660x490x15
08	1/1	01	Prateleira Estante Shelf	808x400x15
09	1/1	01	Travessa traseira Travesaño trasero Rear bumper	808x60x15
10	1/1	01	Pilastra da Porta Puerta pilastra Door Pilaster	660x75x15
11	1/1	01	Frente Fixa Frente Fija Fixed Front	600x435x15
12	1/1	01	Travessa frontal Travesaño frontal Front crossbar	808x60x15
13	1/1	01	Travessa Estrutural Travesa Estructural Travessa Estructural	675x43x15
14	1/1	02	Fundo Fondo Bottom	832x341x3
15	1/1	02	Porta Puerta Door	665x396x15

AVISO

Para limpeza de seu móvel, use uma flanela seca ou umedecida, e não utilize produtos químicos que possam danificar seu produto.

SISTEMA DE MONTAGEM

O sistema de montagem dos produtos, funciona de acordo com a ordem crescente dos números indicados no desenho. Ex: 01, 02, 03, 04... até a conclusão da montagem.

ADVERTENCIA

Para limpeza de su móvil, use una flanela seca o húmeda, y no utilice productos químicos que puedan dañar su producto.

SISTEMA DE MONTAJE

El sistema de montaje de los productos funciona de acuerdo con el orden creciente de los números indicados en el dibujo. Ej.: 01, 02, 03, 04... hasta la conclusión del montaje.

NOTICE

To clean your furniture, use a dry or wet cloth, and do not use chemicals that may damage your product.

ASSEMBLY SYSTEM

The products' assembly system works according to the increasing order of the indicated numbers. For example: 01, 02, 03, 04 ... to the end of the assembly.

Ferragens | Herrajes | Hardware

A 05x Parafuso 5,0x50mm FLA. Tornillo 5,0x50mm FLA. Screw 5,0x50mm FLA.	B 05x Parafuso 4,5x50mm CHT. Tornillo 4,5x50mm CHT. Screw 4,5x50mm CHT.	C 21x Parafuso 3,5x40mm CHT. Tornillo 3,5x40mm CHT. Screw 3,5x40mm CHT.	D 02x Parafuso M4x20mm CHT. ZB. Tornillo M4x20mm CHT. ZB. Screw M4x20mm CHT. ZB.	E 48x Parafuso 3,5x14mm FLA. Tornillo 3,5x14mm FLA. Screw 3,5x14mm FLA.	F 07x Parafuso 3,5x12mm CHT. Tornillo 3,5x12mm CHT. Screw 3,5x12mm CHT.	G 03x Parafuso 4,0x25mm CHT. Tornillo 4,0x25mm CHT. Screw 4,0x25mm CHT.	H 04x Parafuso União 30mm Tornillo Unión 30mm Union Screw 30mm
I 04x Prego 12x12mm Anelado Clavo 12x12mm Anillado Ringed Nails 12x12mm	J 26x Prego 10x10mm Clavo 10x10mm Nail 10x10mm	K 07x Fixador de fundos Fijador de fondos Bottom fixer	L 27x Cavilha 8x25mm Cinta 8x25mm Dowel 8x25mm	M 04x Sapata "L" 16x20mm Zapata "L" 16x20mm "L" shoe 16x20mm	N 02x Suporte metal Soporte metálico Metal support	O 13x Cantoneira plástica Cantenera plástica Plastic angle brackets	P 01x Puxador Concha Tirador Concha Shell Handle
Q 02x Calço Removível Calzado extralibre Removable Shim	R 02x Dobradora SlideOn Baixa Amortecedor 35mm Bisagra SlideOn Baja Amortiguador 35mm Low SlideOn Hinge 35mm Shock Absorber	S 05x Bucha plástica 8mm Bucha de plástico 8mm 8mm plastic bushing	T 03x Suporte de fixação Soporte de fijación Mounting bracket	U 03x Proteção para cantoneira Ángulo de protección Protection angle	V 02x Sachê de cola Bolsa de pegamento Glue bag	W 02x Giz de correção Tiza de corrección Chalk of correction	X 10x Adesivo tapa parafuso 10mm Adhesivo tapón de tornillo 10mm Bolt cover adhesive 10mm

O parafuso (H) deve ser usada somente quando este módulo for acoplado a outro módulo componível Henn.

El tornillo (H) se debe utilizar sólo cuando el módulo está conectado a otro módulo componible Henn.

The screw (H) should be used only when this module is attached to another Henn modular module.

RECOMENDAÇÃO

Para fixar o móvel na parede usar o suporte de fixação (T), o parafuso 3,5x14mm FLA (E), a Bucha 8mm (S) e o parafuso 5,0x50mm FLA (A).

RECOMENDACIÓN

Para conectar el móvil a la pared con el soporte (T), tornillo 3,5 x14mm FLA (E), el casquillo de 8 mm (S) y el 5,0x50mm tornillo FLA (A).

RECOMMENDATION

To fix the furniture to the wall use the mounting bracket (T), the 3.5x14mm FLA (E) screw, the 8mm bushing (S) and the 5.0x50mm FLA screw (A).

RECOMENDAÇÃO

Ao unir um outro produto neste, utilizar 2 Cantoneiras (O) e 4 Parafusos 3,5x14mm FLA (E) na peça 04.

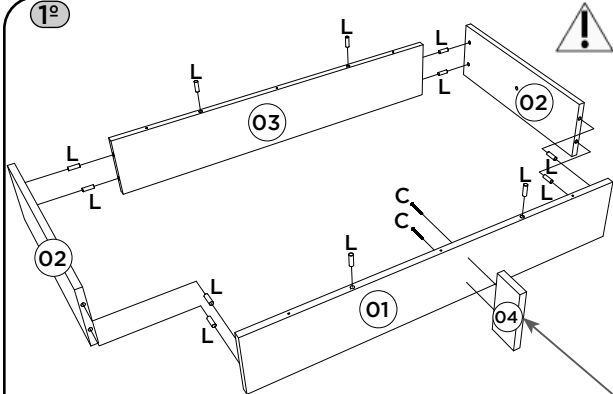

1º

Fazer a furação passante na peça (01) para colocação do parafuso (C) com a peça (04), conforme opção 1 (lado direito) ou opção 2 (lado esquerdo).

Realizar el orificio pasante en la pieza (01) para colocar el tornillo (C) con la pieza (04), según opción 1 (lado derecho) u opción 2 (lado izquierdo).

Make the through hole in the part (01) to place the screw (C) with the part (04), according to option 1 (right side) or option 2 (left side).

Utilizar o sachê de cola (V) em todas as cavilhas (L) do produto.

Con el pegamento sobre (V) en todos los pernos (L) producto.

Use the glue sachet (V) on all the pegs (L) of the product.

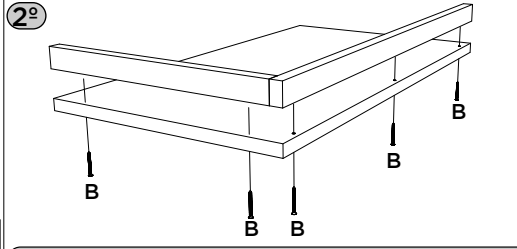

Esse tampo é opcional e é vendido separadamente (C906-114).

Esta vez es opcional y se vende por separado (C906-114).

This top is optional and is sold separately (C906-114).

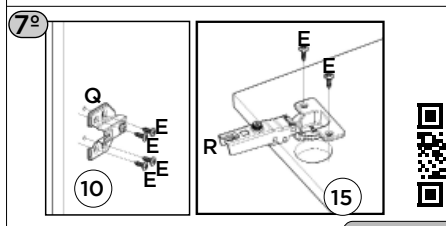
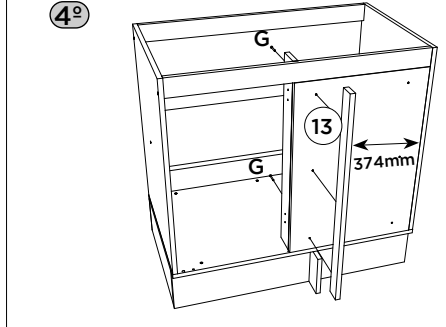
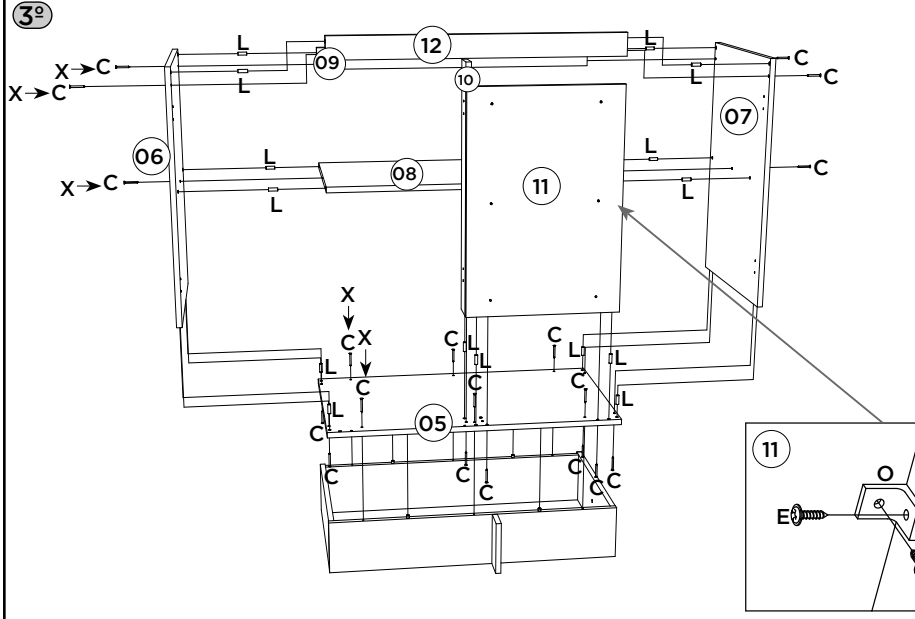
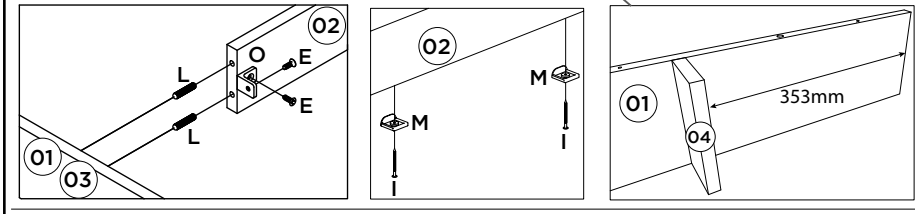

Video: Instalar e regular Dobradiças

Video: instale y ajuste las bisagras

Video: Install and adjust hinges

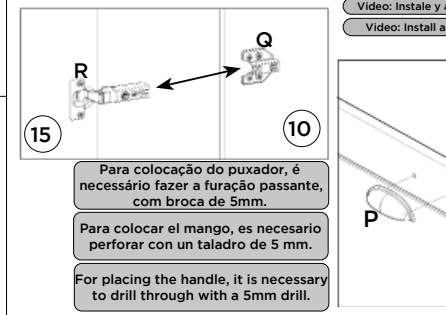

Para colocação do puxador, é necessário fazer a furação passante, com broca de 5mm.

Para colocar el mango, es necesario perforar con un taladro de 5mm.

For placing the handle, it is necessary to drill through with a 5mm drill.

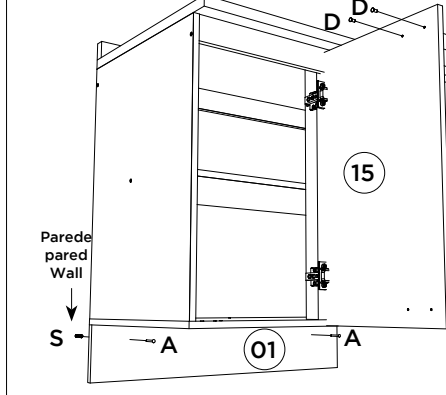
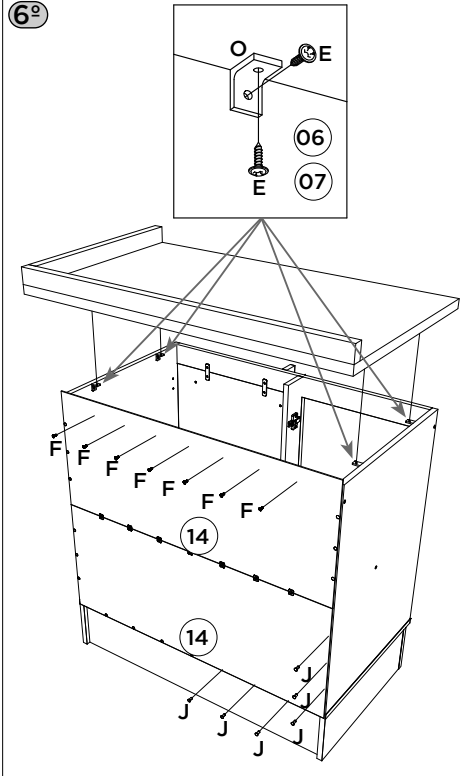
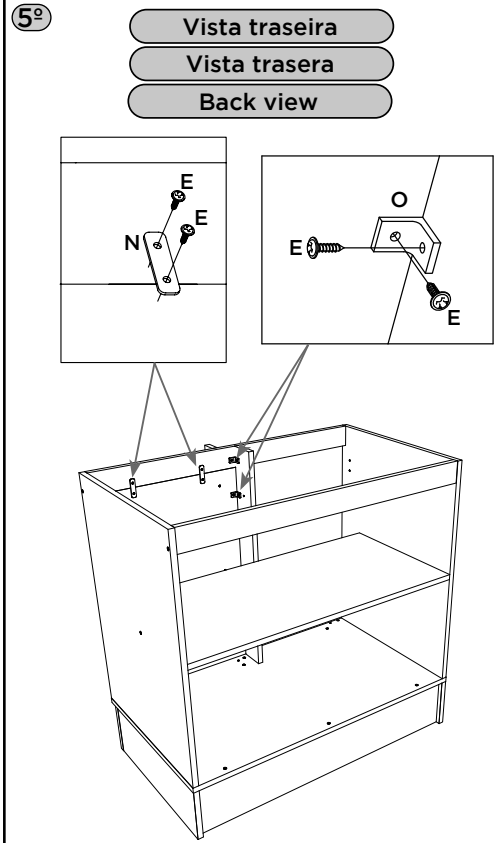

Opção Suspensa

Opción suspendida

Suspended Option

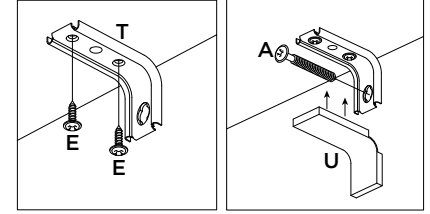

HENNInd. e Com. de Móveis Henn
Mondai - SC - Brasil

☎+55 49 3674.3500

📧@moveishenn
www.henn.com.br**INSTRUÇÕES DE MONTAGEM**INSTRUCCIONES DE MONTAJE
ASSEMBLY INSTRUCTIONS**Balcão Porta Toalha 200mm Americana | Balcón Puerta Toalla 200mm Americana | Counter Towel Door 200mm Americana**

- C362-05 Branco HP
 C362-131 Cinza

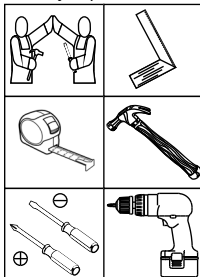
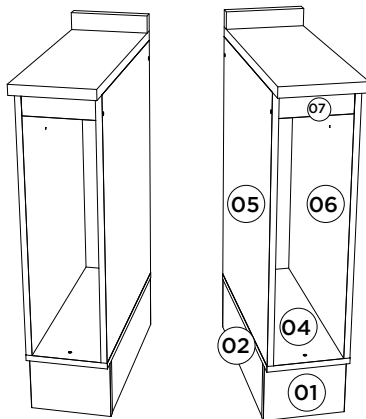
Requisitos para montagem
Requisitor para la montaje
Assembly RequirementsImagens meramente ilustrativas
Imágenes meramente ilustrativas
Images for illustration only**AVISO**

Para limpeza de seu móvel, use uma flanela seca ou umedecida, e não utilize produtos químicos que possam danificar seu produto.

SISTEMA DE MONTAGEM

O sistema de montagem dos produtos, funciona de acordo com a ordem crescente dos números indicados no desenho. Ex: 01, 02, 03, 04... até a conclusão da montagem.

ADVERTENCIA

Para limpieza de su móvil, use una franela seca o húmeda, y no utilice productos químicos que puedan dañar su producto.

SISTEMA DE MONTAJE

El sistema de montaje de los productos funciona de acuerdo con el orden creciente de los números indicados en el dibujo. Ej: 01, 02, 03, 04... hasta la conclusión del montaje.

NOTICE

To clean your furniture, use a dry or wet cloth, and do not use chemicals that may damage your product.

ASSEMBLY SYSTEM

The products' assembly system works according to the increasing order of the indicated numbers. For example: 01, 02, 03, 04 ... to the end of the assembly.

Lista de Peças | Lista de piezas | List of parts

Item	Caixa Caja Box	Qtd Ctd Qty	Descrição Descripción Description	Medidas (mm) Dimensions (mm) Size (measurements) (mm)
01	1/1	01	Rodapé Frontal Frente pie de página Front Footer	200x145x15
02	1/1	02	Rodapé Lateral Pie de página Side Side Footer	450x145x15
03	1/1	01	Rodapé Traseiro Pie de página trasera Rear Footer	168x145x15
04	1/1	01	Base Base Base	490x200x15
05	1/1	01	Lateral esquerda Lateral izquierda Left side	660x490x15
06	1/1	01	Lateral direita Lateral derecha Right side	660x490x15
07	1/1	01	Travessa frontal Travesaño frontal Front crossbar	169x60x15
08	1/1	01	Travessa traseira Travesaño trasero Rear bumper	169x60x15
09	1/1	01	Fundo Fondo Bottom	683x192x3

Ferragens | Herrajes | Hardware

A 01x 	B 02x 	C 10x 	D 16x 	E 05x 	F 20x 	G 01x
H 01x 	I 14x 	J 08x 	K 04x 	L 04x 	M 04x 	N 01x
						O 08x

O parafuso (K) deve ser usada somente quando este módulo for acoplado a outro módulo componível Henn.

Caso houver a necessidade de editar o produto, a fita de borda deverá ser utilizada para acabamento.

El tornillo (K) se debe utilizar sólo cuando el módulo está conectado a otro módulo componible Henn.

En caso de necesidad de editar el producto, la cinta de borde debe utilizarse para el acabado.

The screw (K) should be used only when this module is attached to another Henn modular module.

If you need to edit the product, the edge tape should be used for finishing.

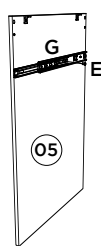
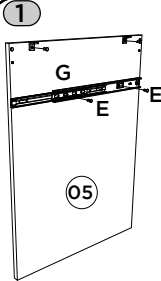

Video: Dicas para fixar a Corrediça

Video: Consejos para arreglar la diapositiva

Video: Tips for Fixing the Slide

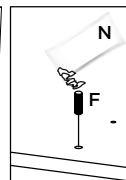
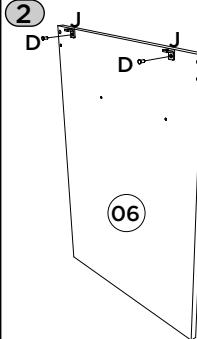

Utilizar o sachê de cola (N) em todas as cavilhas (F) do produto.

Con el pegamento sobre (N) en todos los pernos (F) producto.

Use the glue sachet (N) on all the pegs (F) of the product.

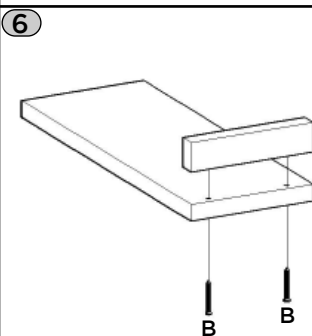
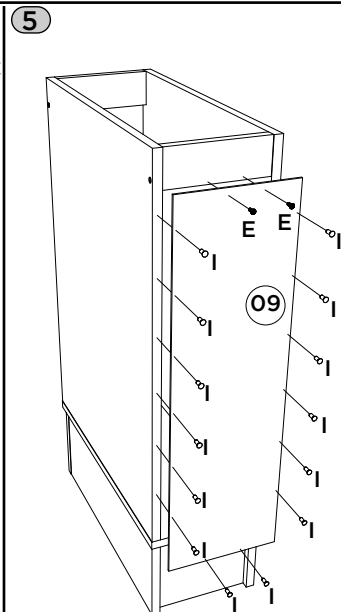
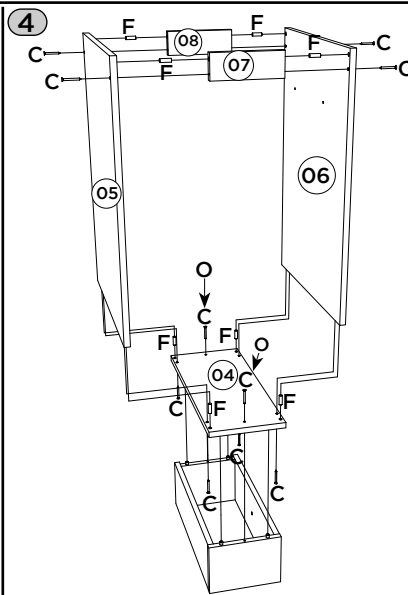
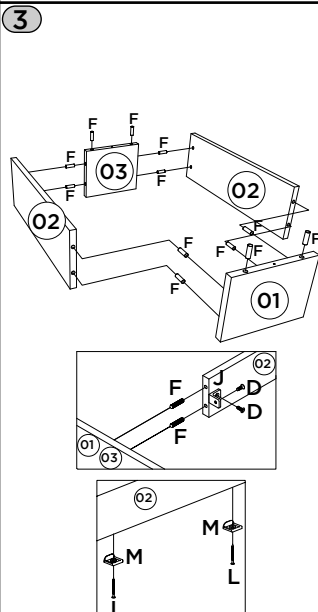

Esse tampo é opcional e é vendido separadamente (C900-114).

Esta vez es opcional y se vende por separado (C900-114).

This top is optional and is sold separately (C900-114).

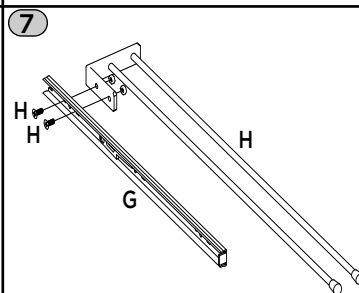

Fixação do toalheiro (H) na corrediça (G).

La fijación de latoalla (H) el control deslizante (G).

fixing the towel rail (H) on the slide (G).

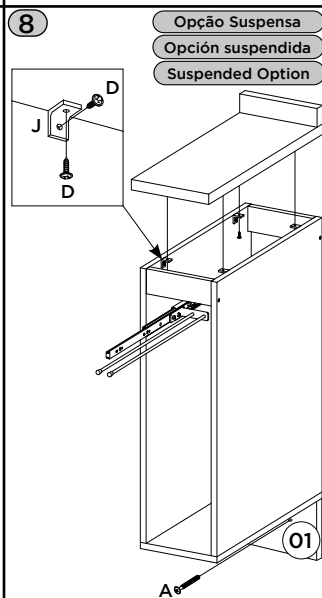

Opção Suspensa

Opción suspendida

Suspended Option

HENNInd. e Com. de Móveis Henn
Mondai - SC - Brasil

☎+55 49 3674.3500

📧@moveishenn
www.henn.com.br**INSTRUÇÕES DE MONTAGEM**INSTRUCCIONES DE MONTAJE
ASSEMBLY INSTRUCTIONS**Tampo Cooktop 800mm | Tampo Cooktop 800mm | Cooktop top 800mm**

- C908-23 Duna
- C908-33 Nero
- C908-114 Calcare

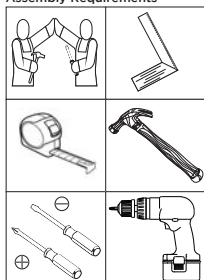
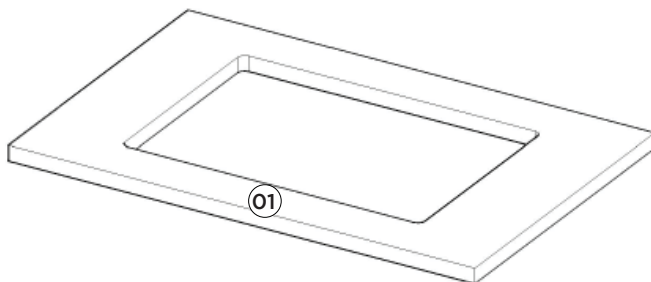
Requisitos para montagem
Requisitor para la montaje
Assembly RequirementsImagens meramente ilustrativas
Imágenes meramente ilustrativas
Images for illustration only**AVISO**

Para limpeza de seu móvel, use uma flanela seca ou umedecida, e não utilize produtos químicos que possam danificar seu produto.

SISTEMA DE MONTAGEM

O sistema de montagem dos produtos, funciona de acordo com a ordem crescente dos números indicados no desenho. Ex: 01, 02, 03, 04... até a conclusão da montagem.

ADVERTENCIA

Para limpieza de su móvil, use una franela seca o húmeda, y no utilice productos químicos que puedan dañar su producto.

SISTEMA DE MONTAJE

El sistema de montaje de los productos funciona de acuerdo con el orden creciente de los números indicados en el dibujo. Ej.: 01, 02, 03, 04... hasta la conclusión del montaje.

NOTICE

To clean your furniture, use a dry or wet cloth, and do not use chemicals that may damage your product.



ASSEMBLY SYSTEM

The products' assembly system works according to the increasing order of the indicated numbers. For example: 01, 02, 03, 04 ... to the end of the assembly.

Lista de Peças | Lista de piezas | List of parts

Item	Caixa Caja Box	Qty Ctd Qty	Descrição Descripción Description	Medidas (mm) Dimensions (mm) Size (measure- ments) (mm)
01	1/1	01	Tampo Tapa Top	800x533x25

Ferragens | Herrajes | Hardware

A		08x	B		04x
Parafuso 3,5x14mm FLA. Tornillo 3,5x14mm FLA. Screw 3,5x14mm FLA.			Cantoneira plástica Cantонера plástica Plastic angle brackets		

 Estas ferragens constam no Pacote do respectivo Balcão.
Estos herrajes constan en el Paquete del respectivo Balcón.
These hardware are included in the Package of the respective Counter.

Esse tampo é opcional e é vendido separadamente

Esta vez es opcional y se vende por separado

This top is optional and is sold separately

Exemplo de como fixar o Tampo Cooktop no produto.

Ejemplo de cómo fijar el Tablero Cooktop en el producto.

Example of how to secure the Cooktop Top to the product.

