

Ref. 1072

Ropero 3 Puertas Correderas / 3-Sliding Door Wardrobe / Roupeiro 3 Portas de Correr

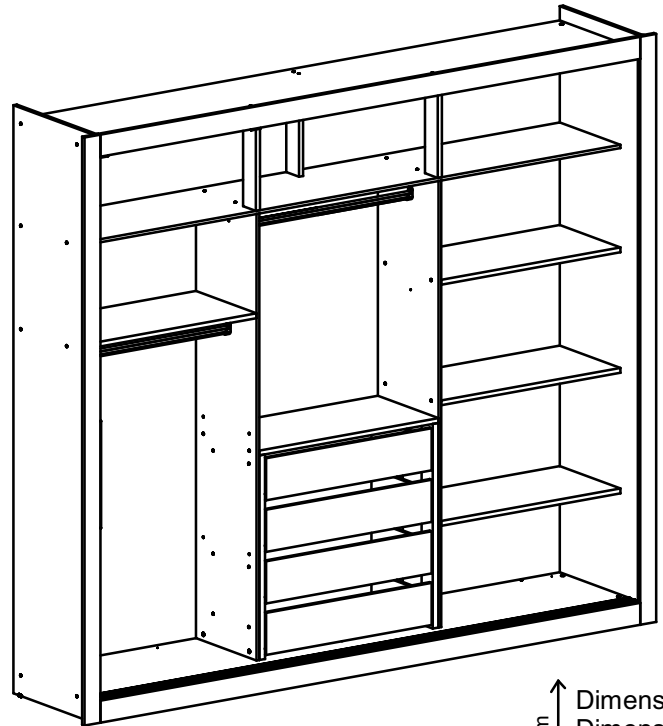

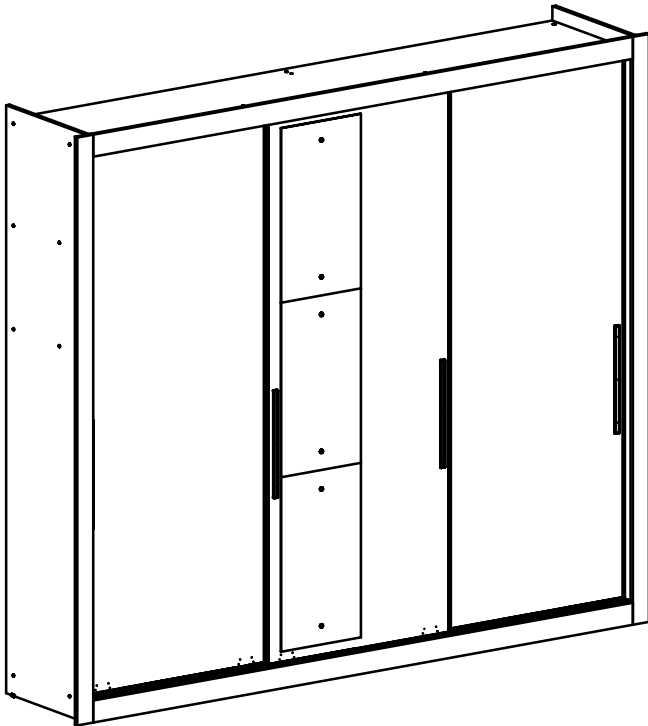





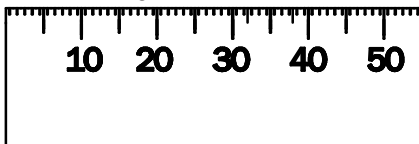







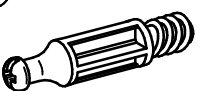



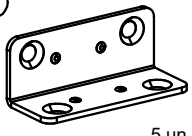

Dimensiones
 Dimensions
 Dimensões

A 2190 mm
 L 2510 mm
 P 520 mm

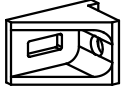
Regla en milímetros / Ruler in millimetres
 Régua em milímetros

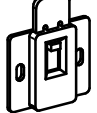

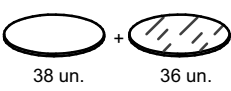
(A)  3,5 x 12 172 un.	(B)  4 x 12 36 un.	(C)  3,5 x 16 12 un.	(D)  3,5 x 25 16 un.	(E)  Pegamento Glue Cola 1 un.	(F)  4 x 50 52 un.
(G)  4 un.	(H)  4 un.	(I)  6 x 30 32 un.	(J)  6 x 50 2 un.	(K)  64 un.	(L)  150 un.
(M)  40 un.	(N)  10 un.	(O)  28 un.	(P)  5 un.	(Q)  4 un.	(R)  10 un.
(S)  8 un.	(T)  6 un.	(U)  6 un.	(V)  8 un.	(W)  38 un. + 36 un.	

Herramientas
 Tools
 Ferramentas



90 min.



Personas Necesarias
 People Required
 Pessoas Necessárias



Consejos de Conservación

- No debe utilizarse en la limpieza, abrasivos como lana de acero, alcohol, vinagre, limón, o productos corrosivos que puedan rayar o quitar la película protectora en los muebles.
- Cuando la limpieza de muebles en general, napa y formica, deben utilizarse un paño ligeramente humedecido y jabón suave.
- Para mover el móvil, es importante que este se levante desde el suelo, debido a que el arrastre puede causar daño estructural.
- No deje a su móvil en exposición a la intemperie.

Conservation Tips

- Do not use abrasive products to clean such as steel wool, alcohol, vinegar, lemon, scouring powder, or corrosive products which can scratch or peel off the protective film of the furniture.
- The best way to clean your furniture is to use a slightly moistened cloth with a mild soap.
- To move the furniture assembled, it is important that it is lifted off the ground, because the drag it can cause structural damage.
- Do not leave your furniture in weather exposure.

Dicas de Conservação

- Não utilizar na limpeza produtos abrasivos tais como: palha de aço, álcool, vinagre, limão, sabonão, ou produtos corrosivos que possam riscar ou descolar a película protetora dos móveis.
- Na limpeza de móveis em geral, napa e fórmicas, deve ser utilizado um pano levemente umedecido e sabão neutro.
- Para a movimentação do móvel, é importante que este seja levantado do chão, pois ao arrastá-lo pode causar avarias estruturais.
- Não deixe o móvel em exposição a intempéries.

Certificado de Garantia

A garantia dos produtos fabricados pela Carraro, abrange eventuais defeitos/vícios de fabricação, no prazo estabelecido pelo Código de Defesa do Consumidor, em seu artigo 26,II, o qual prevê a garantia legal de 90 (noventa) dias.

Peso por estante

Por favor, preste atención a los pesos máximos admitidos por cada compartimento del producto. Tenga cuidado de no exceder estos pesos, con el fin de garantizar la calidad y durabilidad del producto. Es importante recordar que los pesos muestran en caso de ser distribuida en toda el área de la plataforma.

Weight per shelf

Please pay attention to the maximum weights supported by each compartment product. Be careful not to exceed these weights, in order to ensure the quality and durability of the product. It is important to remember also that the weights shown should be distributed throughout the area of the shelf.

Peso por Prateleira

Ao lado são demonstrados os pesos máximos suportados por cada compartimento do produto. Cuide para não exceder esses pesos, afim de garantir a qualidade e a durabilidade do mesmo. É importante lembrar também, que os pesos mostrados devem ser DISTRIBUÍDOS ao longo de toda a área da peça.

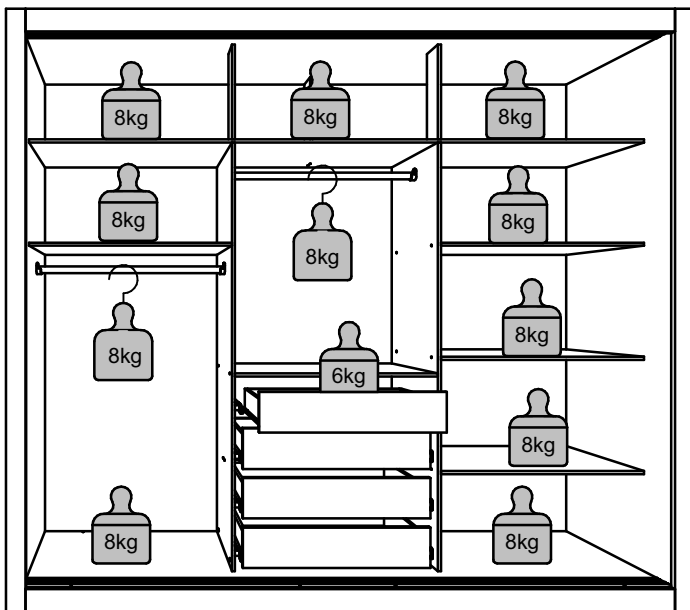

LISTA DE PIEZAS / LIST OF PARTS / RELAÇÃO DE PEÇAS

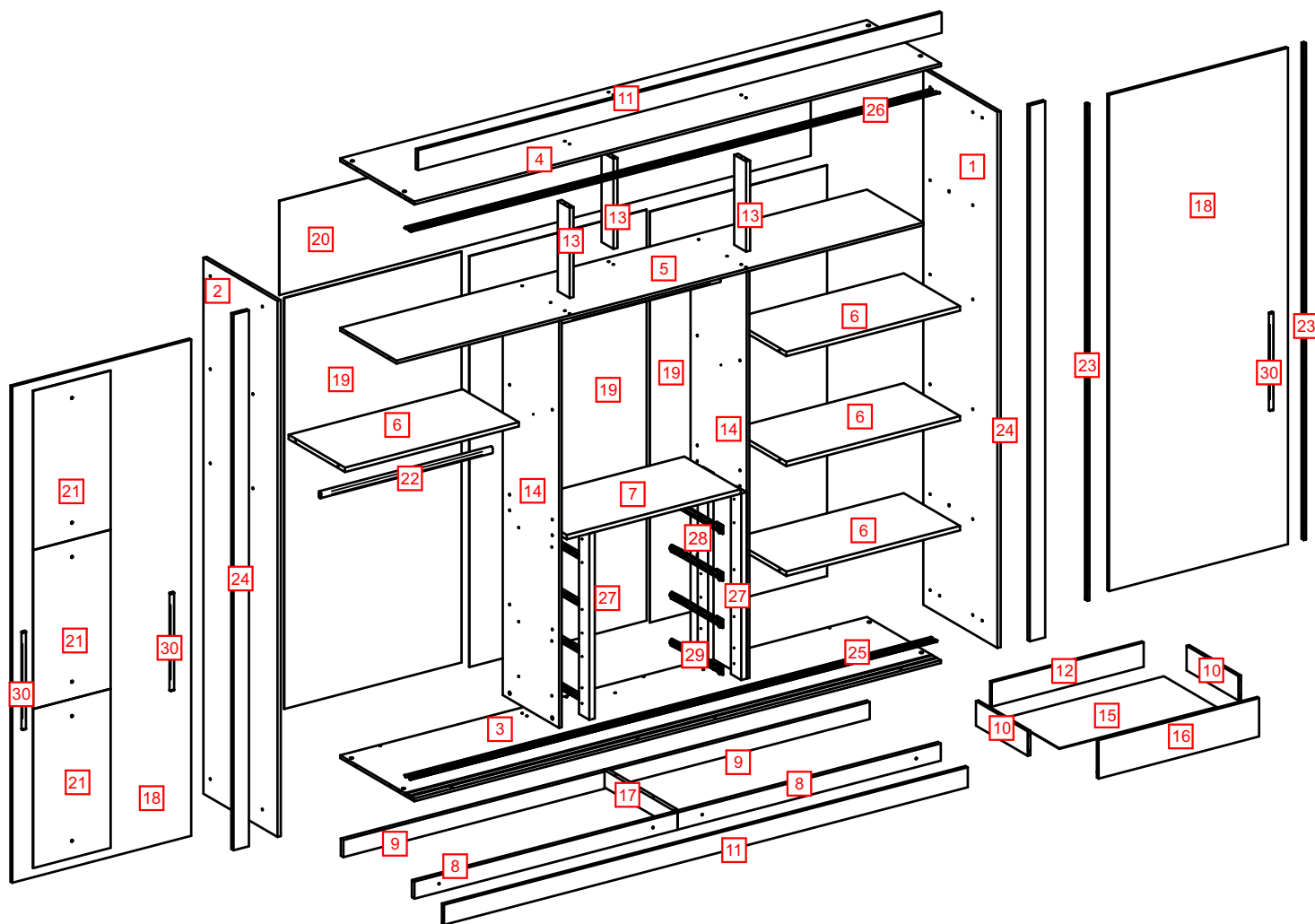

#	Qde	Espanhol	English	Português	Dimensões	Vol.	#	Qde	Espanhol	English	Português	Dimensões	Vol.
1	1	Lateral Derecha	Right Side	Lateral Direita	2190 x 500 x 15	1	16	4	Frente del Cajón	Drawer Front	Frente de Gaveta	727 x 157 x 12	4
2	1	Lateral Izquierda	Left Side	Lateral Esquerda	2190 x 500 x 15	1	17	1	Zocalo Interno	Internal Baseboard	Rodapé Interno	462 x 70 x 18	1
3	1	Base	Base	Base	2385 x 500 x 12	2	18	3	Puerta Corredera	Sliding Door	Porta de Correr	2028 x 810 x 12	3
4	1	Tapa	Top	Tampo	2385 x 500 x 12	2	19	3	Costado Mayor	Biggest Back Panel	Costa Mayor	1679 x 802 x 2,5	3
5	1	Tapa Intermediaria	Intermediate Top	Tampo Intermediário	2385 x 380 x 12	2	20	1	Costado Menor	Smaller Back Panel	Costa Menor	2406 x 385 x 2,5	2
6	4	Repisa	Shelf	Prateleira	787 x 380 x 18	4	21	3	Especjo	Mirror	Espelho	650 x 350 x 3	5
7	1	Tapa Cajones	Drawer Shelf	Tampo Gavetas	787 x 380 x 18	4	22	2	Rolizo Percha	Hanger Rod	Cabideiro	777mm	1
8	2	Zocalo Delantero	Frontal Baseboard	Rodapé Dianteiro	1191 x 70 x 18	2	23	4	Enderezador	Straightener	Desempenador U	2028mm	2
9	2	Zocalo Trasero	Back Baseboard	Rodapé Traseiro	1191 x 70 x 18	2	24	2	Marco Lateral	Side Frame	Moldura Lateral	2190 x 70 x 15	2
10	8	Lateral del Cajón	Drawer Side	Lateral de Gaveta	350 x 100 x 12	1	25	2	Trilho Inferior	Lower Profile	Trilho Inferior	2384mm	2
11	2	Marco Sup. Inf.	Top Bottom Frame	Moldura Sup. Inf.	2371 x 82 x 15	2	26	2	Trilho Superior	Upper Profile	Trilho Superior	2384mm	2
12	4	Costado del Cajón	Drawer Back	Costa de Gaveta	688 x 100 x 12	4	27	2	Separ. Cajón Delant.	Front Drawer Spacer	Afastador Gav. Diant.	762 x 70 x 25	4
13	3	Pilastra	Pilastra	Pilastra	368 x 80 x 18	1	28	2	Separ. Cajón Trasero	Back Drawer Spacer	Afastador Gav. Tras.	762 x 70 x 25	4
14	2	Division	Division	Divisão	1663 x 380 x 12	1	29	4	Corredera Metalica	Metalic Slide	Corrediça	350mm	4
15	4	Fondo del Cajón	Drawer Bottom	Fundo de Gaveta	712 x 355 x 2,5	4	30	4	Tirador	Handle	Puxador	400mm	1

1

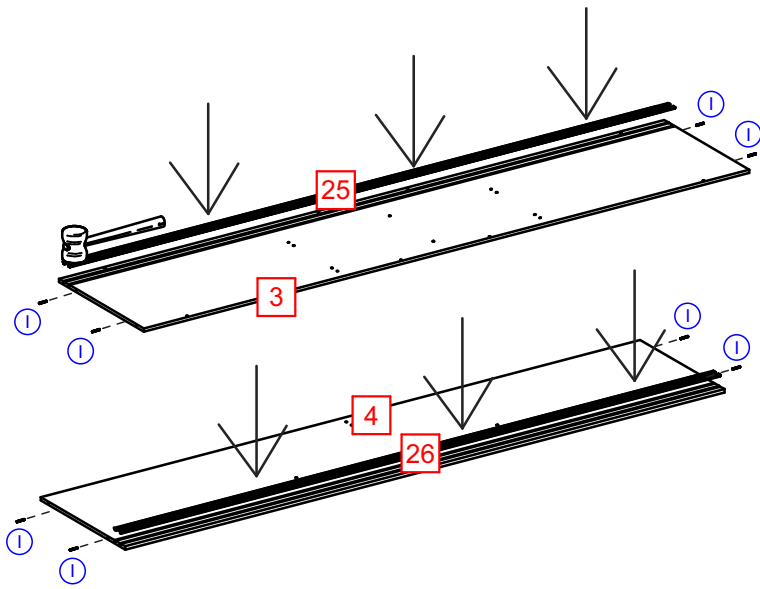

2

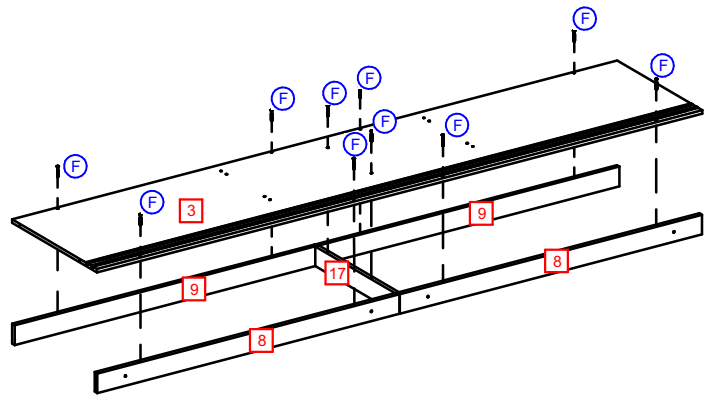

3

Cantidad en este paso = 12 conjuntos
 Quantity in this step = 12 sets
 Qde nesse passo = 12 conjuntos

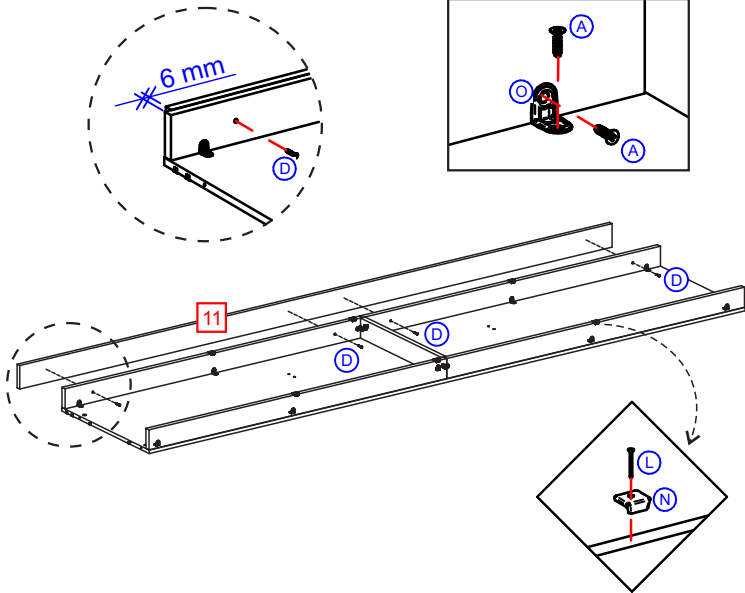

Distribuya uniformemente 3 herrajes L y N, a cada lado, a lo largo de los zócalos 8 y 9.
 Evenly distribute 3 fittings L and N, on each side, along baseboards 8 and 9.
 Distribuir uniformemente 3 acessórios L e N, de cada lado, ao longo dos rodapés 8 e 9.

4

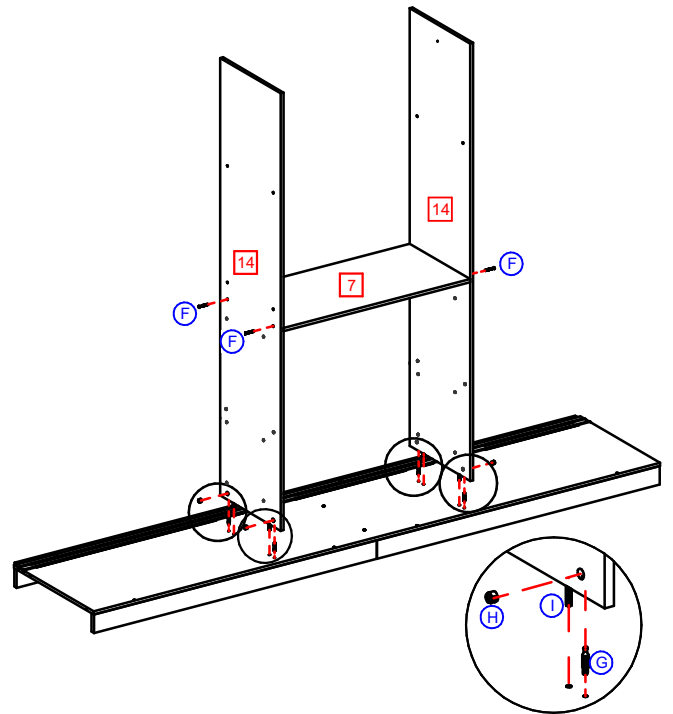

5

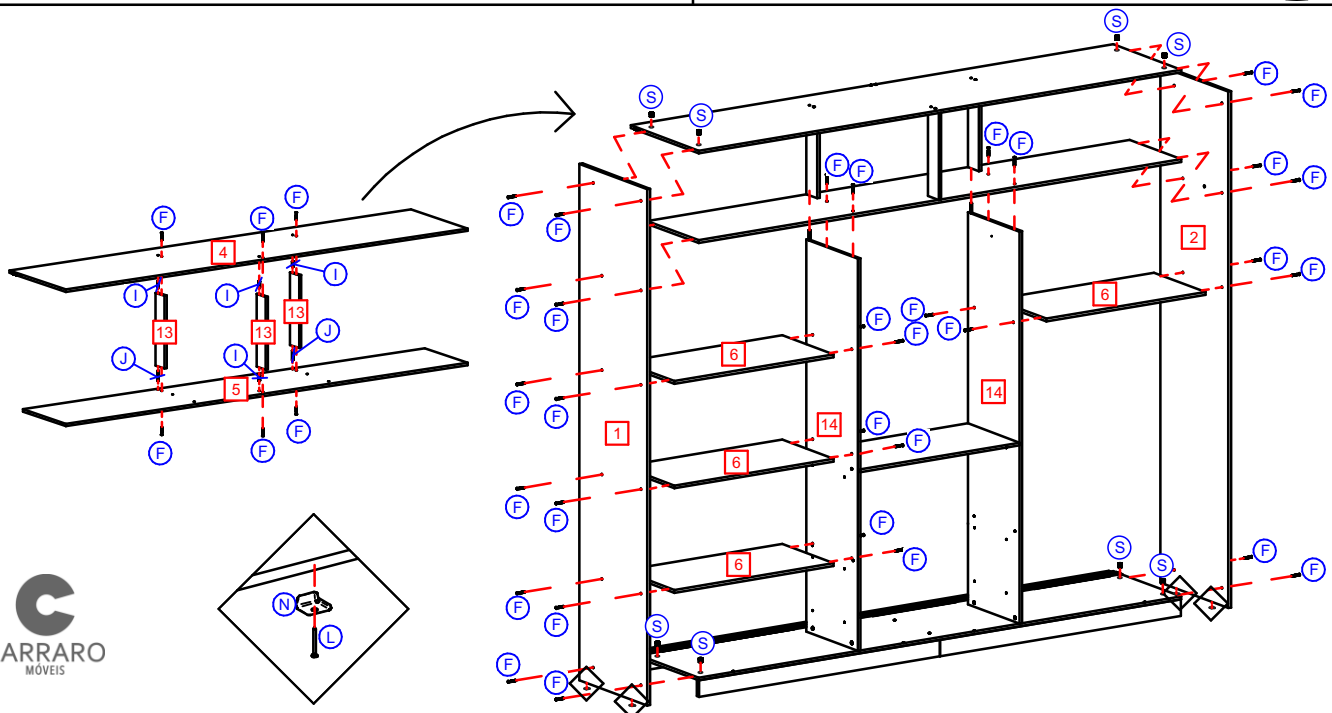

- 6 Fijar costado con clavos cada 150mm.
 Fasten back panel with nails every 150mm.
 Fixar costas com pregos, a cada 150mm.

 También es importante fijar los lugares indicados por la línea de puntos, para una mejor estabilidad de lo mueble.

It is also important to fix it in the places indicated by the dotted line, for better stability of the furniture.

Importante fixar também nos locais indicados pela linha pontilhada, para melhor estabilidade do móvel.

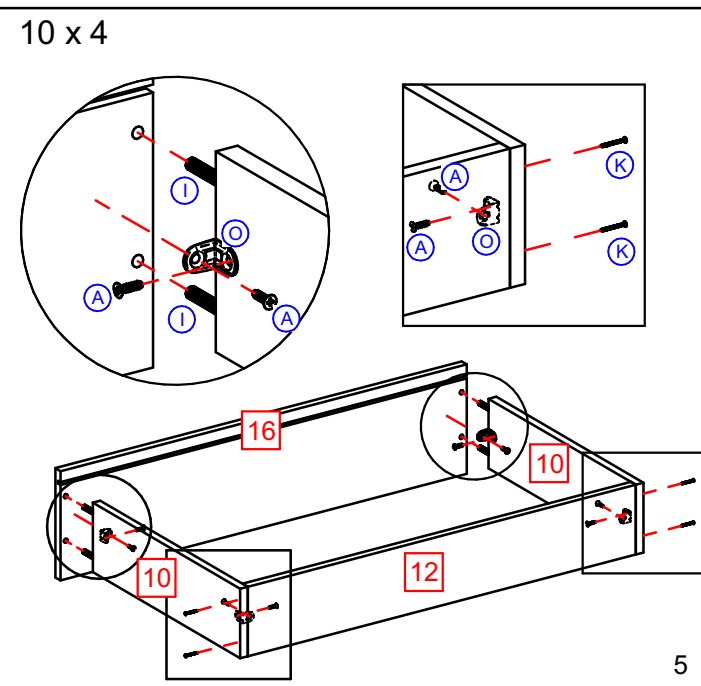
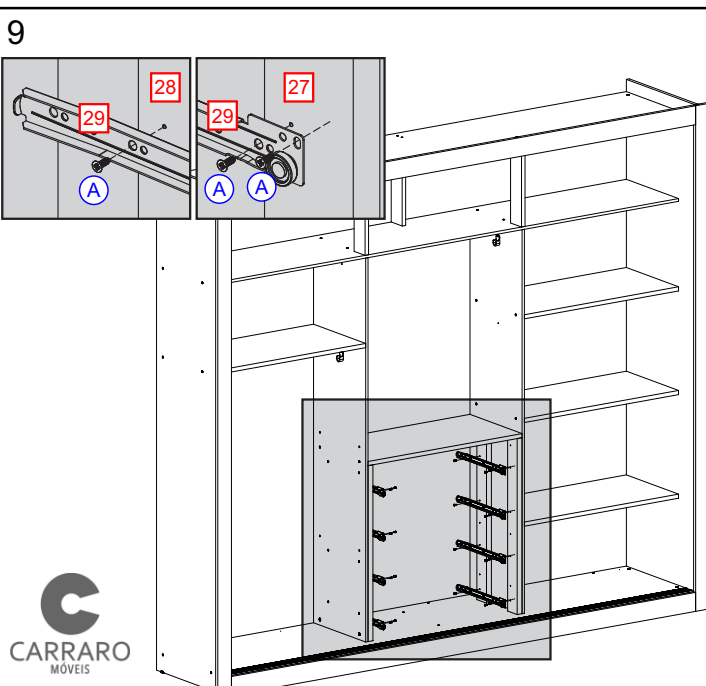
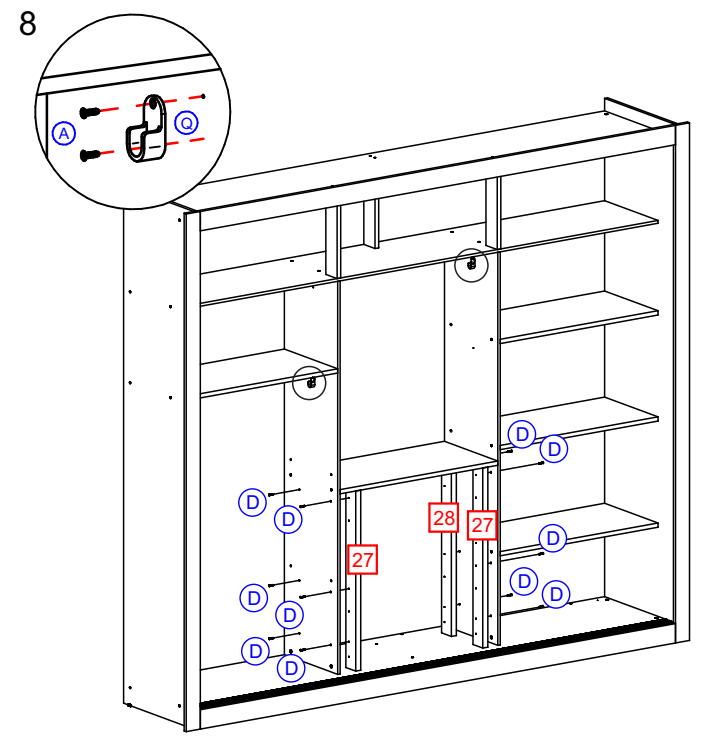
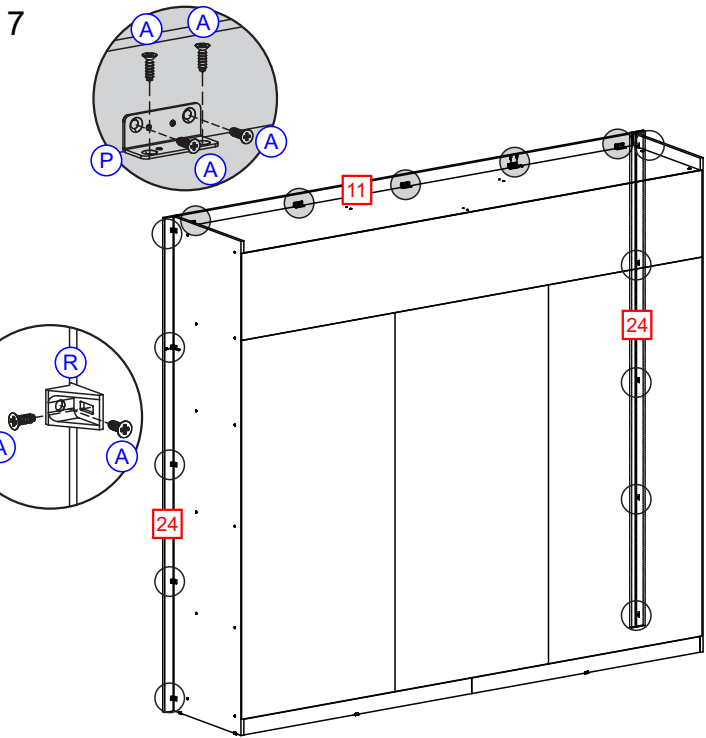
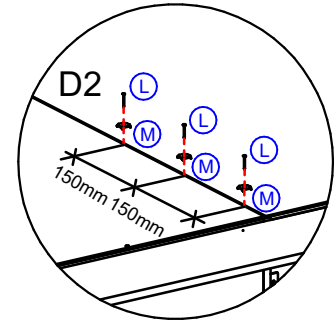
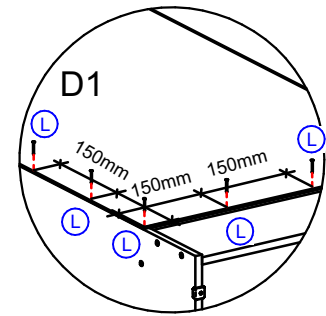
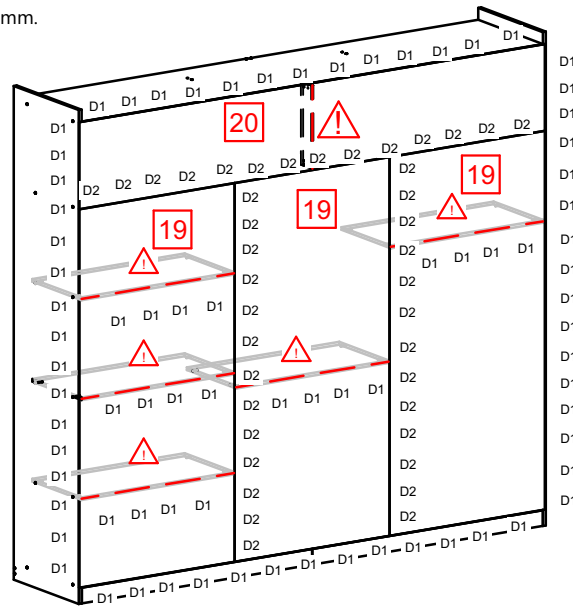

11 x 4

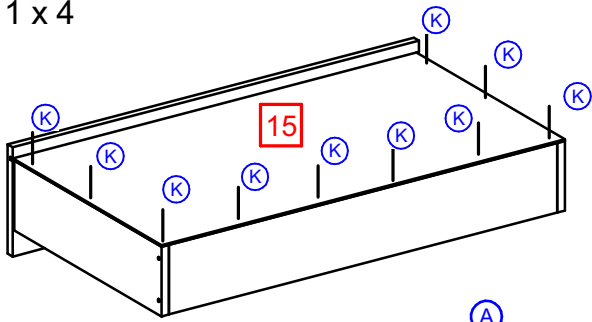

12 x 4

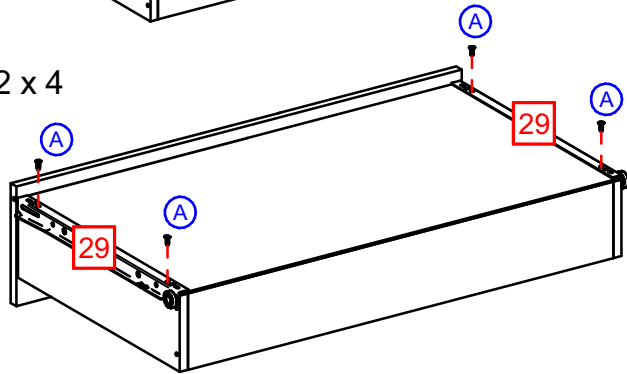

13

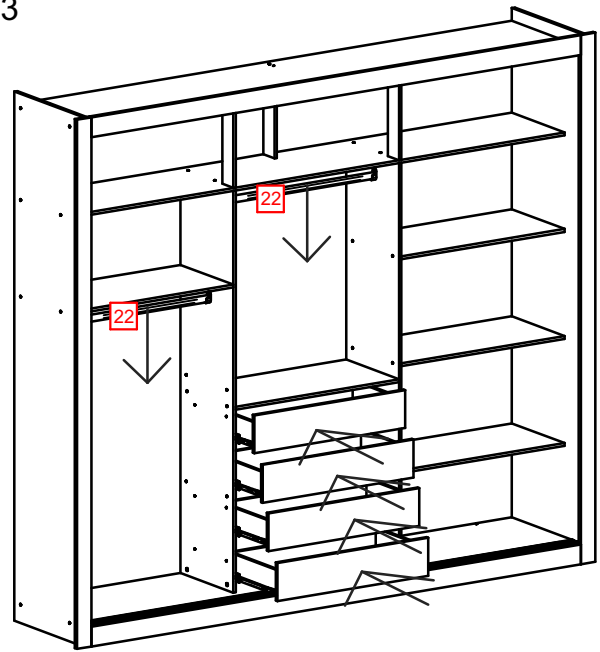

14 x 2 PUERTAS LATERALES / SIDE DOORS / PORTAS LATERAIS

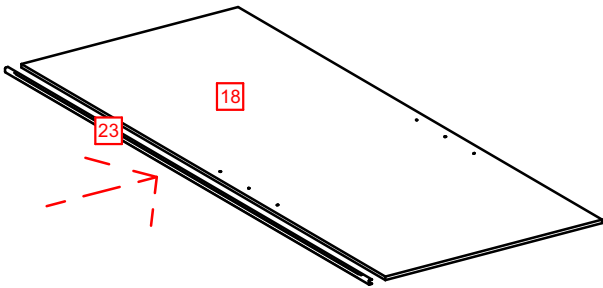

14 x 1 PUERTA CENTRAL / CENTRAL DOOR / PORTA CENTRAL

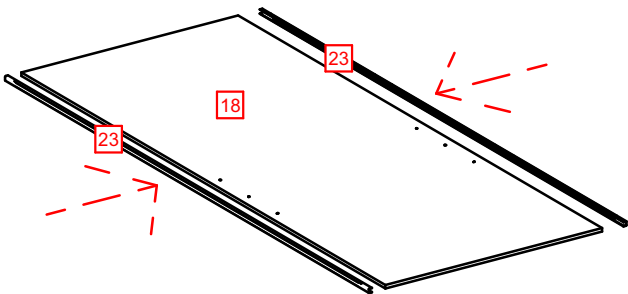

15 x 3

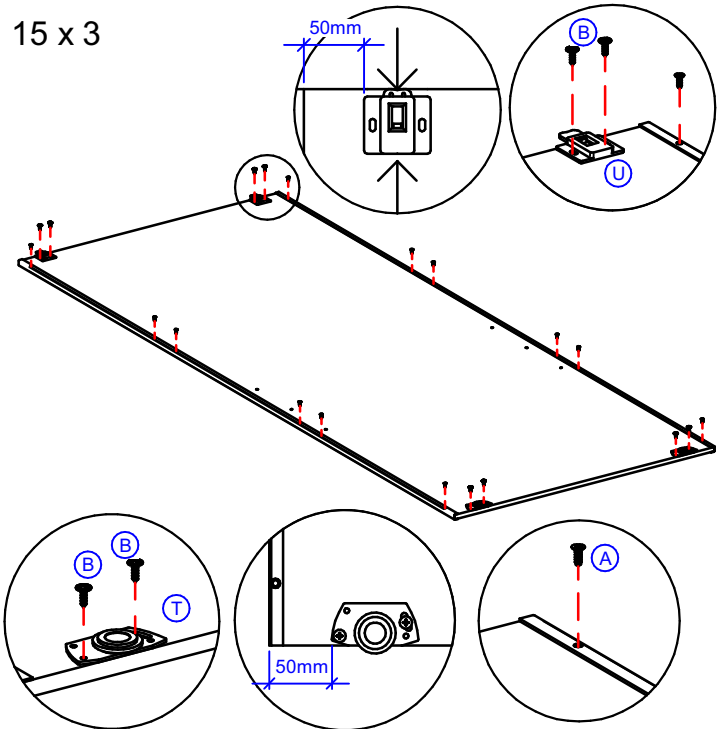

16 x 3 Taladrar agujeros para los tiradores
Drill the holes for handles
Fazer os furos para os puxadores

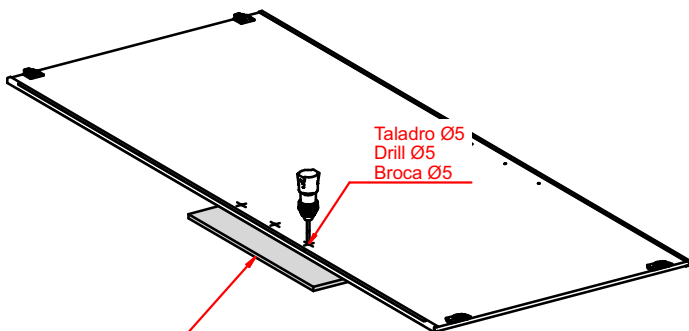

Taladro Ø5
Drill Ø5
Broca Ø5

Utilice una pieza para un mejor acabado
Use retail for better finish
Use retalho para melhor acabamento

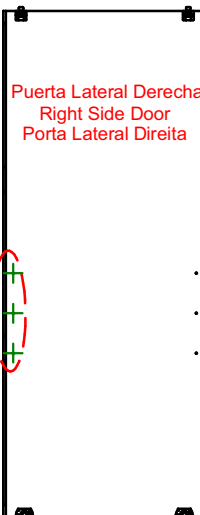

Puerta Lateral Derecha
Right Side Door
Porta Lateral Direita

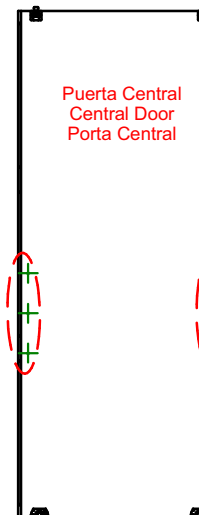

Puerta Central
Central Door
Porta Central

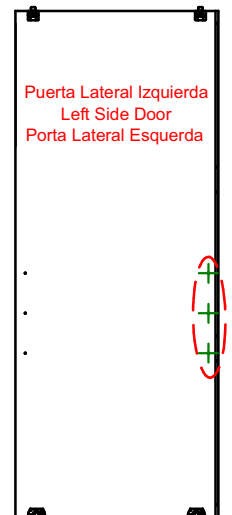

Puerta Lateral Izquierda
Left Side Door
Porta Lateral Esquerda

17

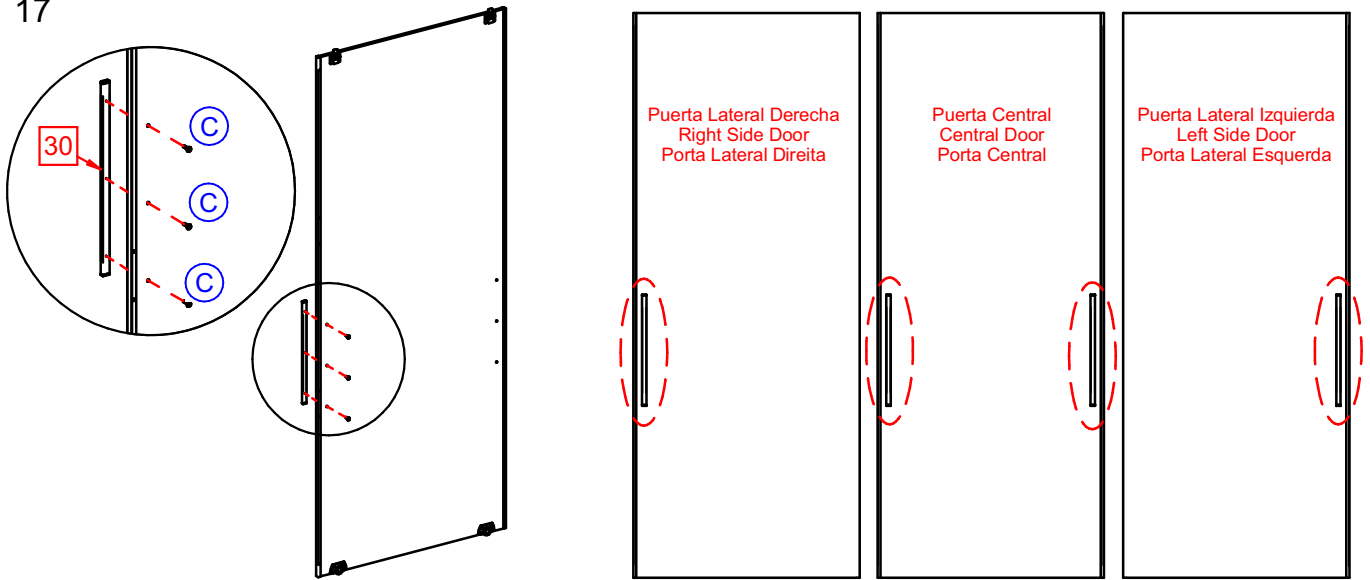

18 - SOLAMENTE PUERTA CENTRAL / ONLY CENTRAL DOOR / SOMENTE PORTA CENTRAL

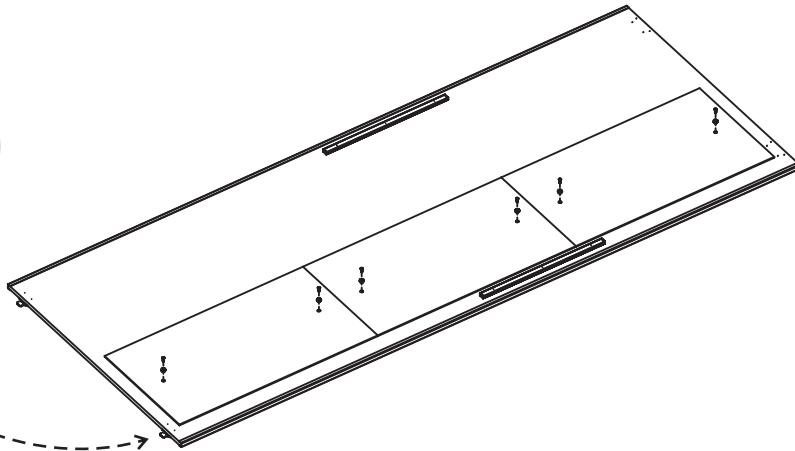
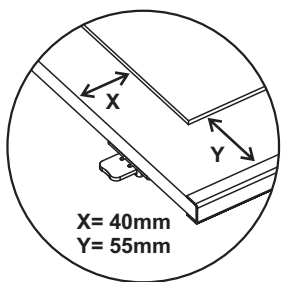

Accesorios incluidos en el embalaje del espej
Accessories included in the mirror package
Acessórios acompanham a embalagem dos espelhos

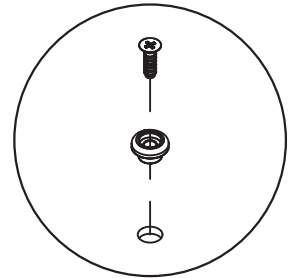

19

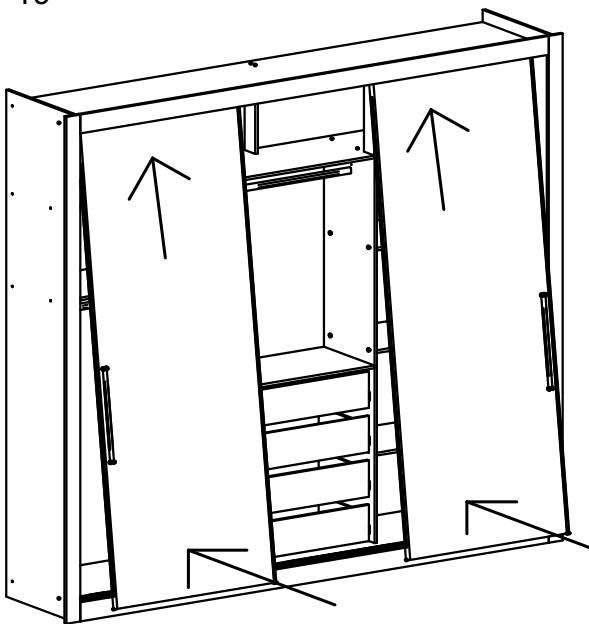

20

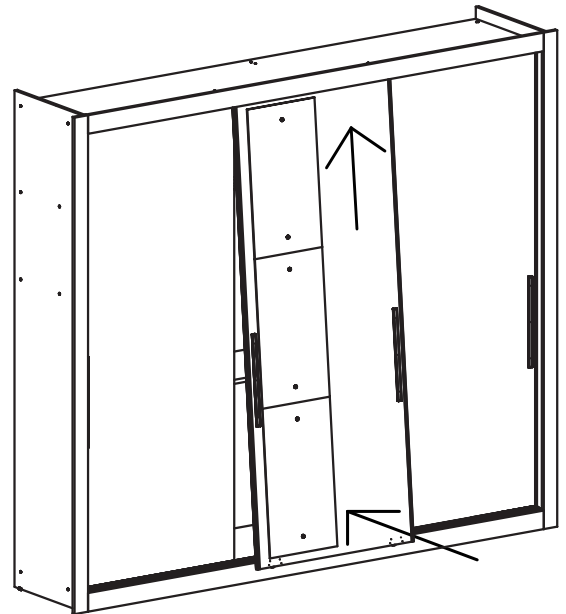
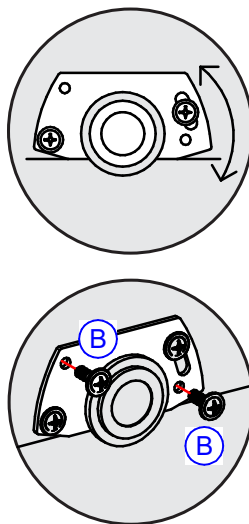

Poner dos batientes en las puertas deslizantes, según el detalle abajo.
Please, put two door stops on sliding doors, as per detail under.
Colocar dois batentes nas portas de correr, conforme o detalhe abaixo.

