

MÓDULO AÉREO 3 PORTAS 120CM / AIR MODULE 3 DOORS 120CM / MÓDULO DE AIRE 3 PUERTAS 120CM
PH-3054

Montagem

Recomenda-se a leitura prévia das instruções de montagem e profissionais especializados para montar.

Assistência

Caso ocorra problema com algum dos componentes, sublinhe-o, identifique o problema e retorne esta relação, via fax ou outro meio de comunicação disponível para o representante.

Assinatura do cliente

Assembly

Before the assembling is recommended to read carefully the assembly instruction by professional assemblers.

Assistance

If happen problems with any component, underline the same, identify the problem and send back this relation immediately, by fax or other way.

Client signature

Montaje

Se recomienda la lectura previa de las instrucciones de montaje y profesionales especializados para montarlos.

Assistencia

Caso sucedan problemas con alguno de los componentes, subraye el componente, identifique el problema, y retorne esta copia via fax u otro medio de comunicación posible.

Assinatura del cliente

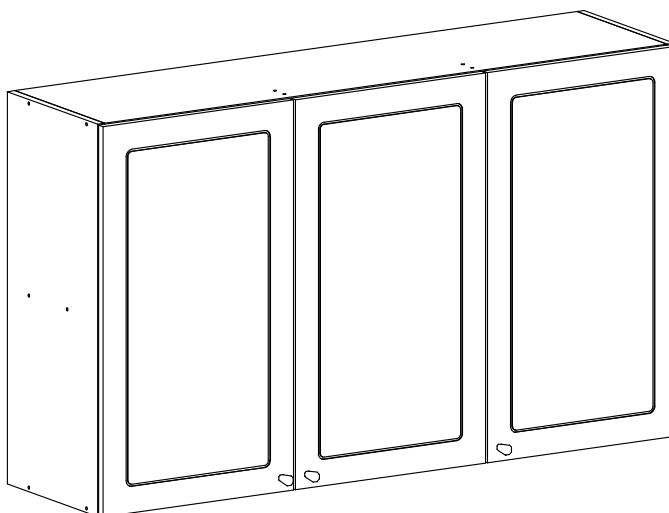

Atenção / Attention / Atención

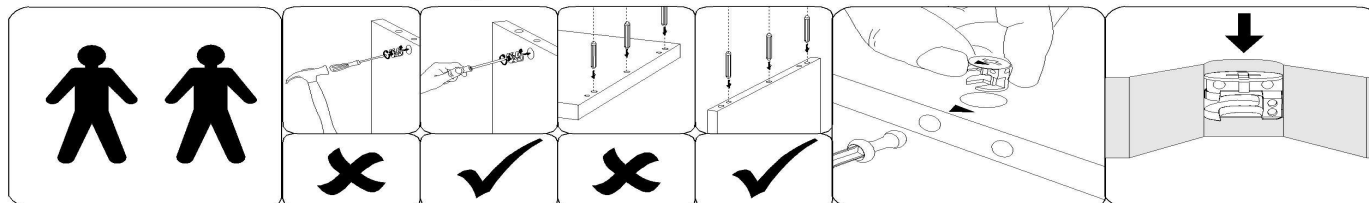

A Herval se reserva o direito de efetuar alterações nos produtos de suas linhas sem aviso prévio, quando entender necessário.

Herval reserves the right to effect modifications in the products, without previous advice, when understand necessary.

Herval se reserva el derecho de hacer las modificaciones que juzgue necesarias en sus productos, sin aviso previo, cuando lo crea necesario.

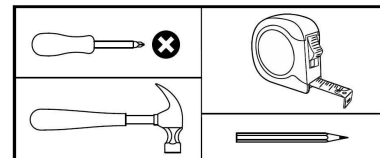
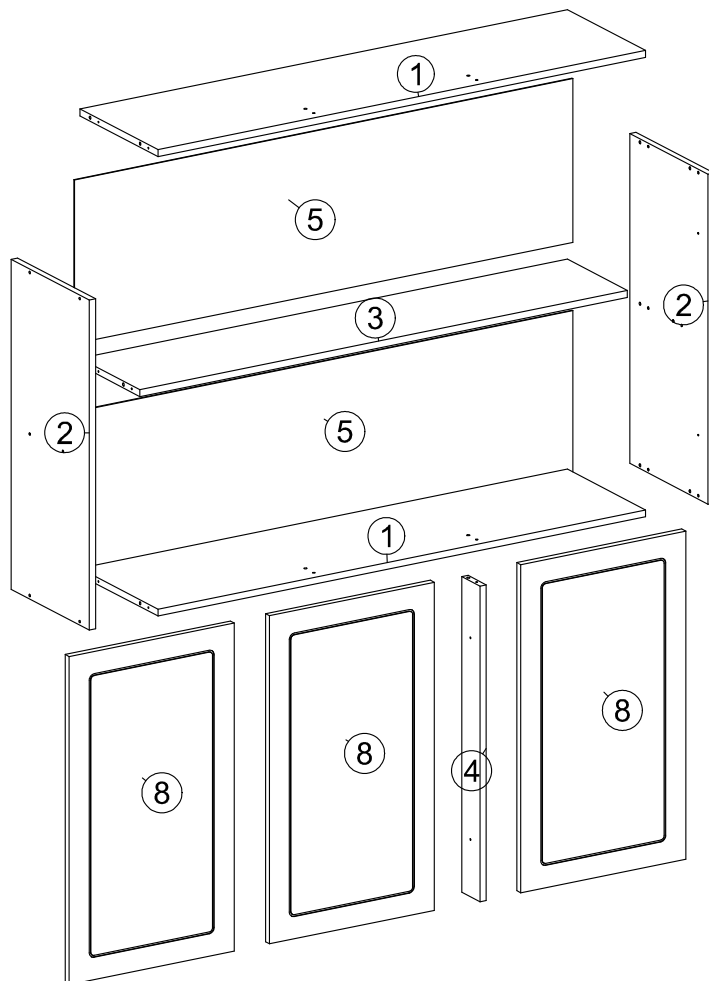

LISTA DE PEÇAS / PARTS LIST / LISTA DE PIEZAS

Volume 1

ÍNDICE_ / INDEX	CÓD. / CODE	PEÇA / PART / PIEZA	MED/MEASURE	QTDE / QUANT / CANT
1	158904L	BASE TAMPO	1170.0x300.0x15.0	2
2	158905L	LATERAL	710.0x300.0x15.0	2
3	158906L	PRATELEIRA	1170.0x230.0x15.0	1
4	158907L	TRAVESSA	679.0x70.0x15.0	1
5	158908L	FUNDO	1196.0x352.0x3.0	2
8	158909L	PORTA	706.0x396.0x15.0	3
9	1607042	PUX DIAMANTE 26X19X11MM CHAMPAGNE	XXXXXXX	3
-	K072602	KIT DOBRADIÇAS	-	1
-	K072603	KIT ACESSÓRIOS	-	1

LISTA DE ACESSÓRIOS / FITTINGS LIST / LISTA DE ACCESORIOS

				CÓD./ CODE: K072603	
REF.	PEÇA	PART	PIEZA	QTDE	CÓDIGO
A	PREGO 10 X 10 C/CABEÇA - Ø1,5 x 23mm	NAIL 10 X 10 - Ø1,5 x 23mm	CLAVO - Ø1.5 x 23mm	36	1605365
B	FIXADOR PARA COSTAS ZINCO BR	Back Panel Bracket	Soporte Panel Trasero	8	1601469
C	CANTONEIRA 18x18 (ZB)	18x18 Corner	Cantoneira 18x18	1	1604301
D	BUCHA 8mm	BUSH 8mm	TARUGO 8mm	4	1602625
E	SUPORTE FIXAÇÃO AÉREO	AIR SUPPORT FIXING	APOYO FIJACIÓN AIRE	4	XXXXXXX
F	PROTECAO SUPORTE FIXAÇÃO AÉREO	PROTECTION SUPPORT FITTING AIRSPACE	PROTECCIÓN SOPORTE MONTAJE DE AÉREO	4	XXXXXXX
G	CAVILHA DE MADEIRA 6X40	Dowel Ø6 x 40 mm	Tarugo Ø6 x 40 mm	14	1604742
H	PARAFUSO 6 X 60 CAB. FLANGEADO	Screw Ø6 x 60 mm	Tornillo Ø6 x 60 mm	4	1606857
I	PARAFUSO 4 X 14 CAB. CHATA REBAIXADA PHILIPS	Screw Ø4 x 14 mm	Tornillo Ø4 x 14 mm	14	1602420
J	PARAFUSO 4 X 50 CAB. CHATA PHILIPS	Screw Ø4 x 50 mm	Tornillo Ø4 x 50 mm	14	XXXXXXX
K	PARAFUSO 3.5 X 30 CAB. CHATA PHILIPS	Screw Ø3.5 x 30 mm	Tornillo Ø3.5 x 30 mm	3	1604658
L	PARAFUSO 4 X 25 CAB. CHATA PHILIPS	Screw Ø4 x 25 mm	Tornillo Ø4 x 25 mm	4	1607862
M	TAPA FURO ADESIVO PAPEL 15MM LINEO	15mm HOLES COVER ADHESIVE LINE	ADESIVO TAPA HUECO 15mm LINEA	4	1607532
N	TAPA FURO ADESIVO PAPEL 15mm	15mm HOLES COVER ADHESIVE	ADESIVO TAPA HUECO 15mm	16	XXXXXXX
O	GIZ CERA BRANCO Ø14x8MM	WAX CHALKS Ø14x8MM	TIZAS DE CERA Ø14x8MM	1	XXXXXXX
P	GIZ CERA FENDI - CEDRO Ø14x8MM	WAX CHALKS Ø14x8MM	TIZAS DE CERA Ø14x8MM	1	XXXXXXX
Q	GIZ CERA GRAFITE - CINZA Ø14x8MM	WAX CHALKS Ø14x8MM	TIZAS DE CERA Ø14x8MM	1	XXXXXXX
R	GIZ CERA LINEO Ø14x8MM	WAX CHALKS Ø14x8MM	TIZAS DE CERA Ø14x8MM	1	XXXXXXX

KIT DOBRADIÇAS / HINGES KIT / KIT BISAGRAS

				CÓD./ CODE: K072602	
REF.	PEÇA	PART	PIEZA	QTDE	CÓDIGO
A10	CALÇO 35MM BAIXO	CHOICE 35mm	ELECCIÓN 35mm	6	1607864
A15	DOBRADIÇA CANECO 35mm COLO ALTO	HING MUG 35mm	TAZA CON BIZAGRA 35mm	6	1603789
I	PARAFUSO 4 X 14 CAB. CHATA REBAIXADA PHILIPS	Screw Ø4 x 14 mm	Tornillo Ø4 x 14 mm	24	1602420

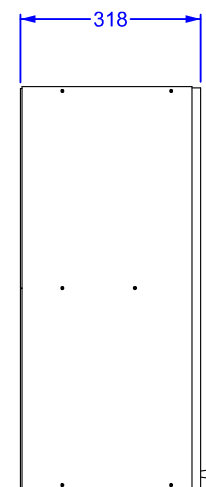
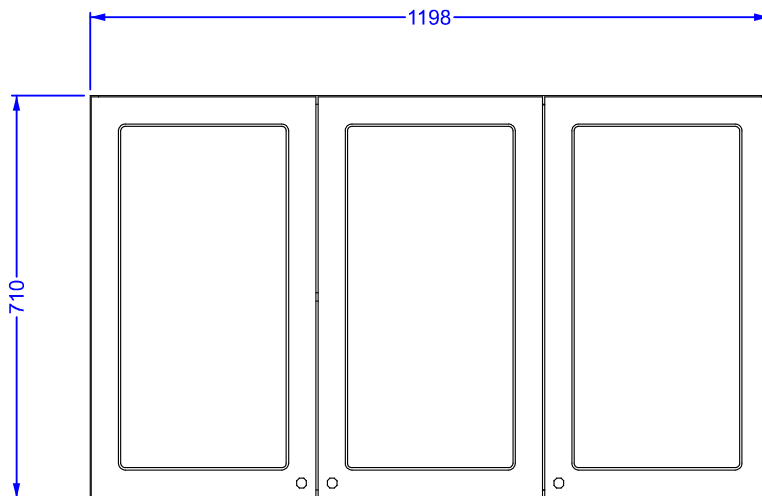

PASSO 1
STEP 1
PASO 1

PEÇAS NECESSÁRIAS
PARTS REQUIRED
PIEZAS NECESSARIAS

INDICE	QUANT.
1	2
3	1
4	1

FERRAGEM NECESSÁRIA
HARDWARE REQUIRED
HERRAMIENTA NECESSARIA

INDICE	IMAGEM	QTDE
G		14

FERRAMENTAS NECESSÁRIAS
TOOL REQUIRED
HERRAMIENTA NECESSARIA

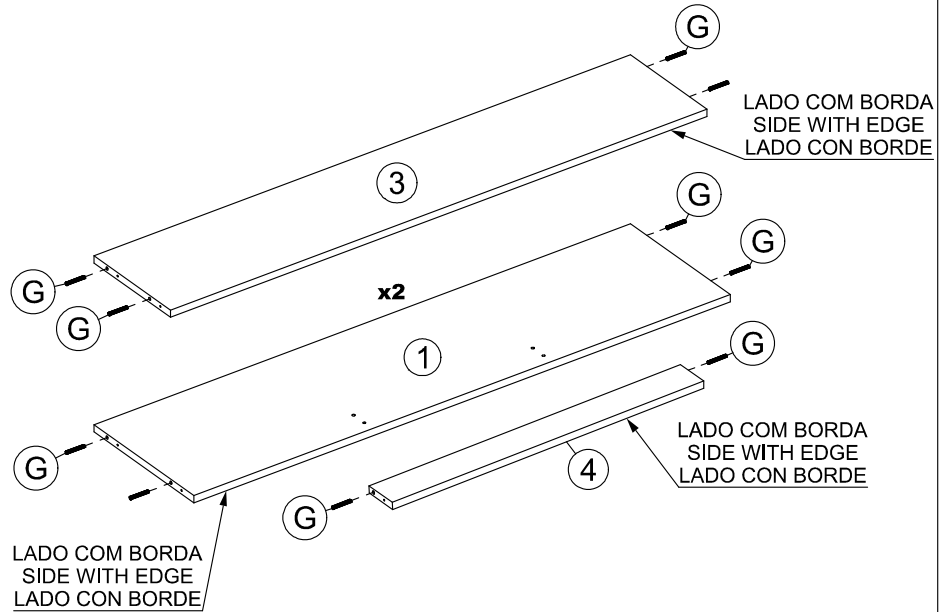
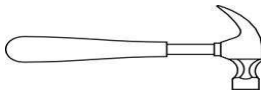



PASSO 2
STEP 2
PASO 2

PEÇAS NECESSÁRIAS
PARTS REQUIRED
PIEZAS NECESSARIAS

INDICE	QUANT.
2	2
4	1

FERRAGEM NECESSÁRIA
HARDWARE REQUIRED
HERRAMIENTA NECESSARIA

INDICE	IMAGEM	QTDE
A10		6
I		12

FERRAMENTAS NECESSÁRIAS
TOOL REQUIRED
HERRAMIENTA NECESSARIA

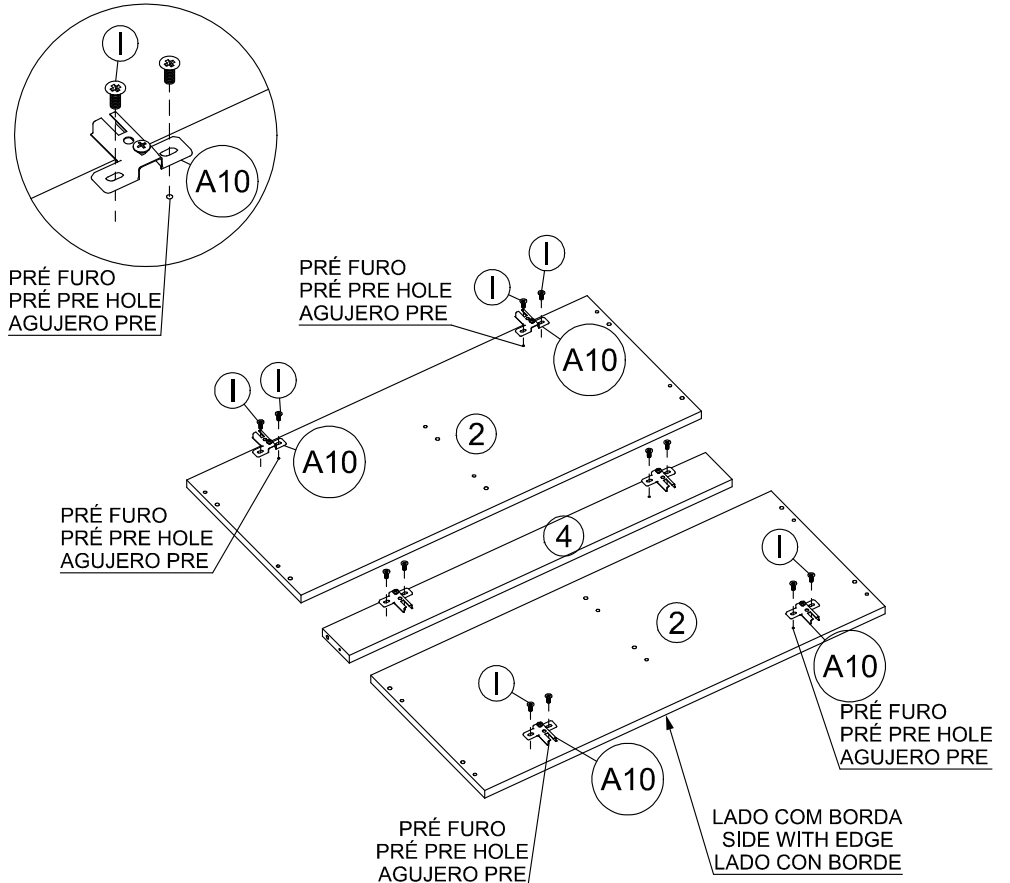
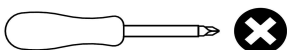



**PASSO 3
STEP 3
PASO 3**

PEÇAS NECESSÁRIAS
PARTS REQUIRED
PIEZAS NECESARIAS

INDICE	QUANT.
1	1
2	1
3	1

FERRAGEM NECESSÁRIA
HARDWARE REQUIRED
HERRAMIENTA NECESARIA

INDICE	IMAGEM	QTDE
J		4
N		4

FERRAMENTAS NECESSÁRIAS
TOOL REQUIRED
HERRAMIENTA NECESARIA

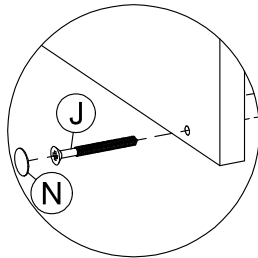
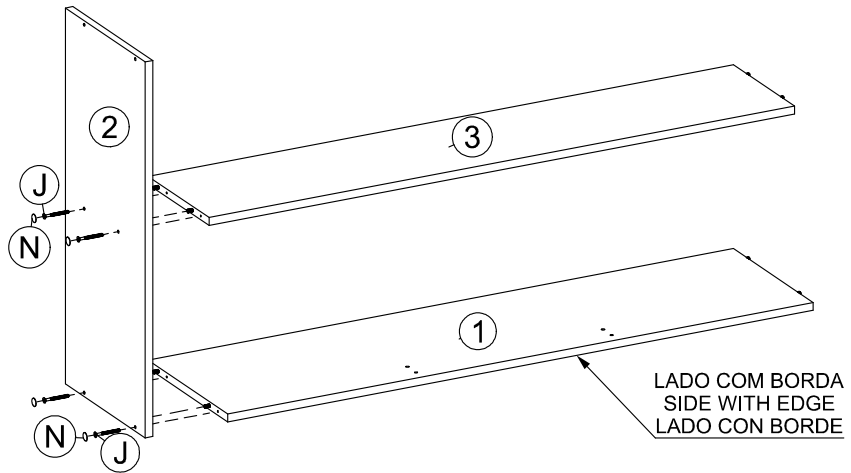
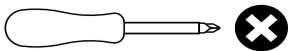



**PASSO 4
STEP 4
PASO 4**

PEÇAS NECESSÁRIAS
PARTS REQUIRED
PIEZAS NECESARIAS

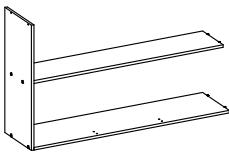
INDICE	QUANT.
4	1



FERRAGEM NECESSÁRIA
HARDWARE REQUIRED
HERRAMIENTA NECESARIA

INDICE	IMAGEM	QTDE
J		1
M		2
N		2

FERRAMENTAS NECESSÁRIAS
TOOL REQUIRED
HERRAMIENTA NECESARIA

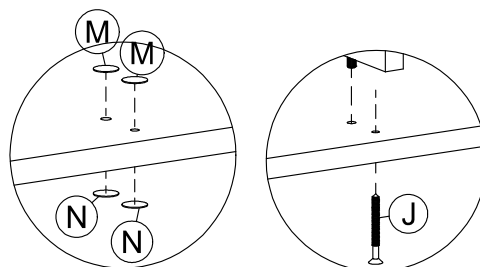
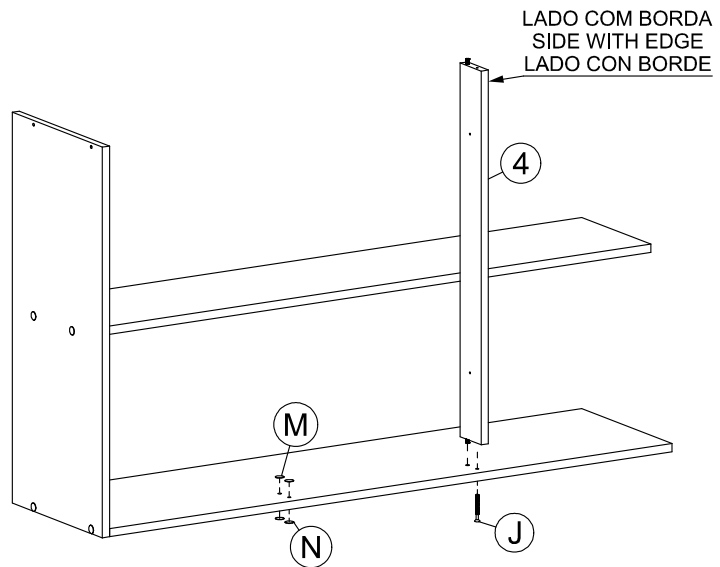
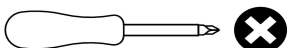

**PASSO 5
STEP 5
PASO 5**

PEÇAS NECESSÁRIAS
PARTS REQUIRED
PIEZAS NECESARIAS

INDICE	QUANT.
1	1

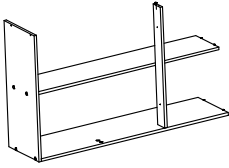

FERRAGEM NECESSÁRIA
HARDWARE REQUIRED
HERRAMIENTA NECESARIA

INDICE	IMAGEM	QTDE
C		1
I		2
J		3
N		2

FERRAMENTAS NECESSÁRIAS
TOOL REQUIRED
HERRAMIENTA NECESARIA

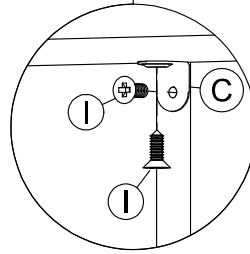
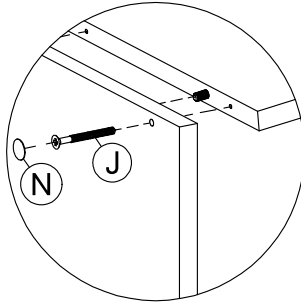
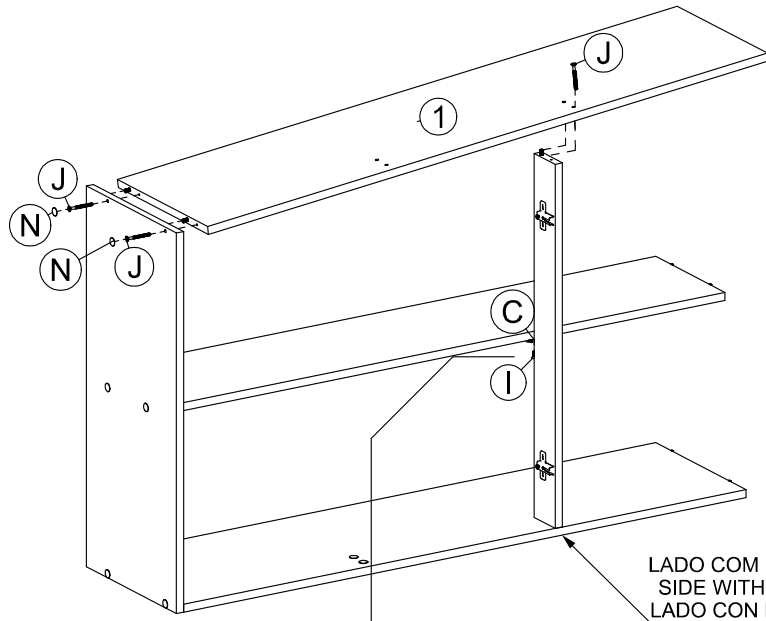
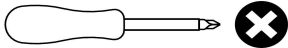

**PASSO 6
STEP 6
PASO 6**

PEÇAS NECESSÁRIAS
PARTS REQUIRED
PIEZAS NECESARIAS

INDICE	QUANT.
2	1

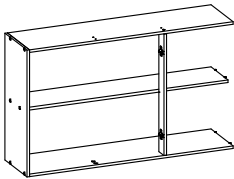

FERRAGEM NECESSÁRIA
HARDWARE REQUIRED
HERRAMIENTA NECESARIA

INDICE	IMAGEM	QTDE
J		6
N		6

FERRAMENTAS NECESSÁRIAS
TOOL REQUIRED
HERRAMIENTA NECESARIA

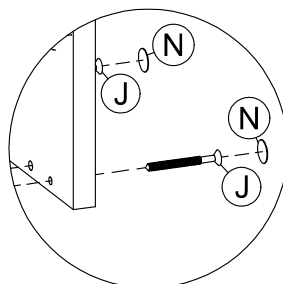
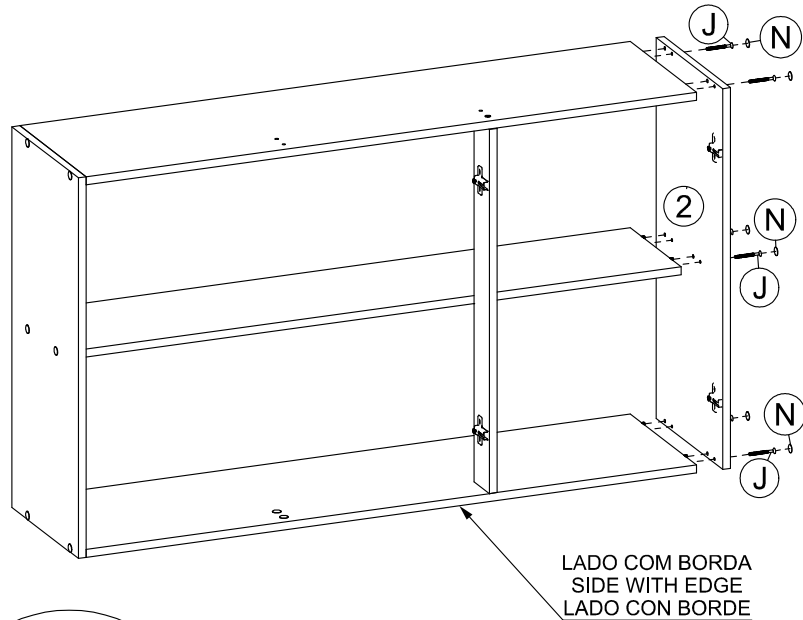
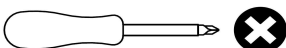

**PASSO 7
STEP 7
PASO 7**

PEÇAS NECESSÁRIAS
PARTS REQUIRED
PIEZAS NECESARIAS

INDICE	QUANT.
5	2

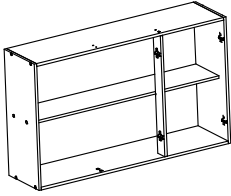

FERRAGEM NECESSÁRIA
HARDWARE REQUIRED
HERRAMIENTA NECESSARIA

INDICE	IMAGEM	QTDE
A		36
B		8

FERRAMENTAS NECESSÁRIAS
TOOL REQUIRED
HERRAMIENTA NECESSARIA

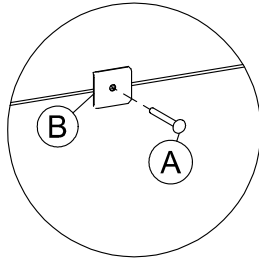
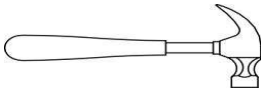

LADO SEM BORDA
SIDE WITHOUT EDGE
LADO SIN BORDE

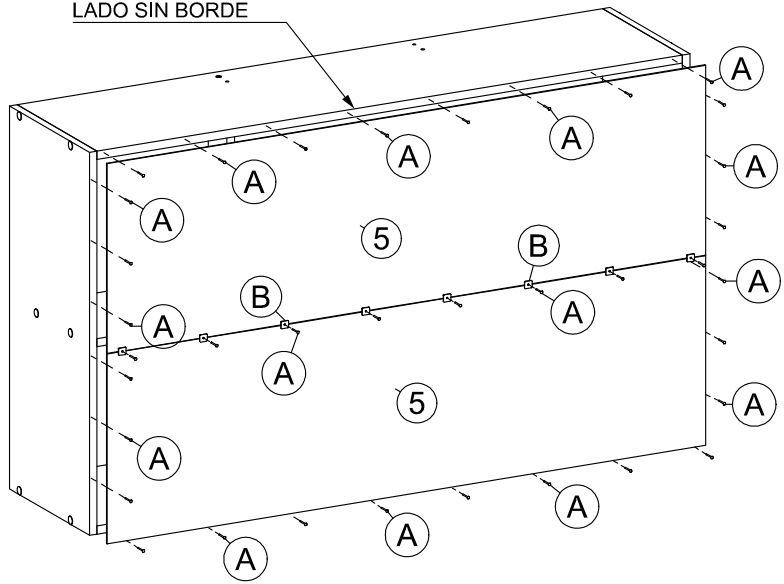

**PASSO 8
STEP 8
PASO 8**

PEÇAS NECESSÁRIAS
PARTS REQUIRED
PIEZAS NECESARIAS

INDICE	QUANT.
8	3

FERRAGEM NECESSÁRIA
HARDWARE REQUIRED
HERRAMIENTA NECESSARIA

INDICE	IMAGEM	QTDE
A15		6
I		12

FERRAMENTAS NECESSÁRIAS
TOOL REQUIRED
HERRAMIENTA NECESSARIA

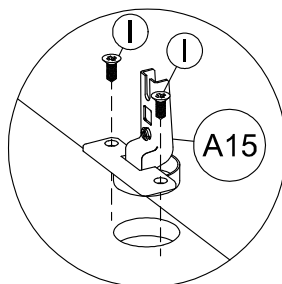
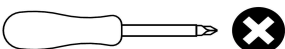

x3

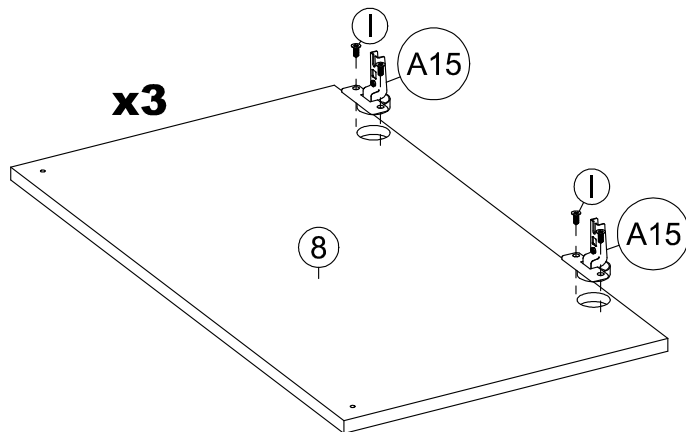

PASSO 9
STEP 9
PASO 9

PEÇAS NECESSÁRIAS
PARTS REQUIRED
PIEZAS NECESARIAS

INDICE	QUANT.
8	3
9	3

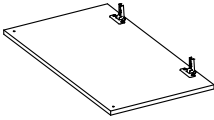

FERRAGEM NECESSÁRIA
HARDWARE REQUIRED
HERRAMIENTA NECESSARIA

INDICE	IMAGEM	QTDE
K		3

FERRAMENTAS NECESSÁRIAS
TOOL REQUIRED
HERRAMIENTA NECESSARIA

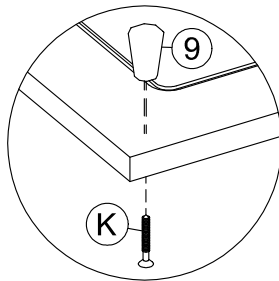
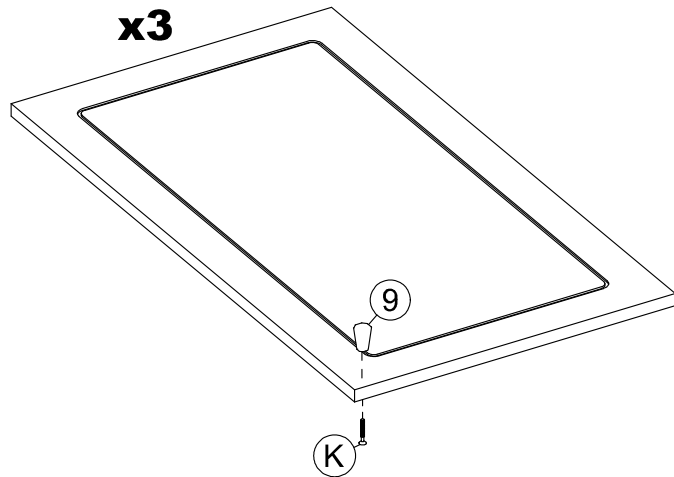
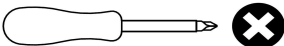

PASSO 10
STEP 10
PASO 10

PEÇAS NECESSÁRIAS
PARTS REQUIRED
PIEZAS NECESARIAS

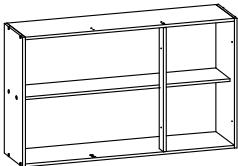

FERRAGEM NECESSÁRIA
HARDWARE REQUIRED
HERRAMIENTA NECESSARIA

INDICE	IMAGEM	QTDE
D		4
E		4
F		4
H		4
I		12
L		4

FERRAMENTAS NECESSÁRIAS
TOOL REQUIRED
HERRAMIENTA NECESSARIA

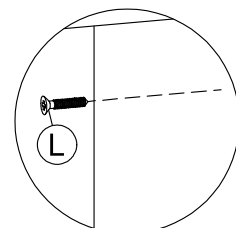
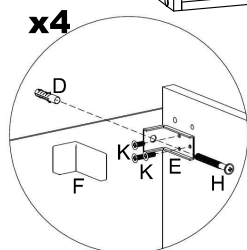
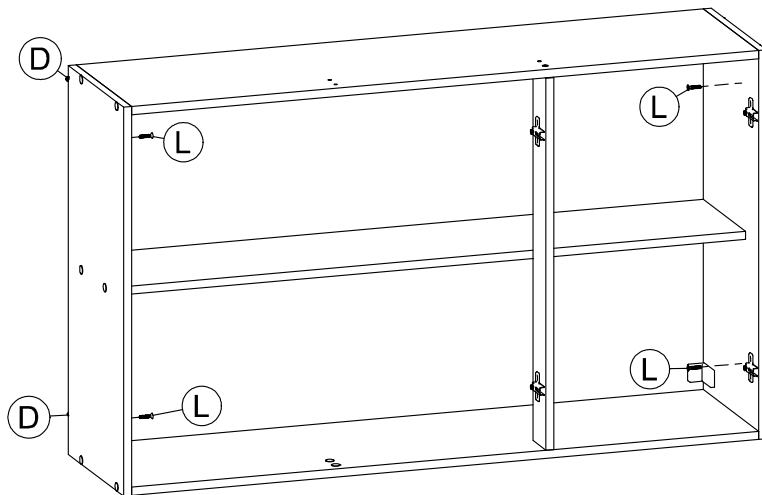
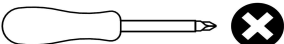

Accessório usado para fixar móvel na parede.
Accessories used to fix the furniture to the wall.
accesorios utilizados para fijar los muebles a la pared.

Parafusos usados para unir um módulo a outro.
Screws used to attach one module to another.
Tornillos utilizados para unir un módulo a otro.

PASSO 11
STEP 11
PASO 11

PEÇAS NECESSÁRIAS
PARTS REQUIRED
PIEZAS NECESARIAS

INDICE	QUANT.
8	3

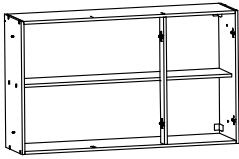

FERRAGEM NECESSÁRIA
HARDWARE REQUIRED
HERRAMIENTA NECESARIA

FERRAMENTAS NECESSÁRIAS
TOOL REQUIRED
HERRAMIENTA NECESARIA

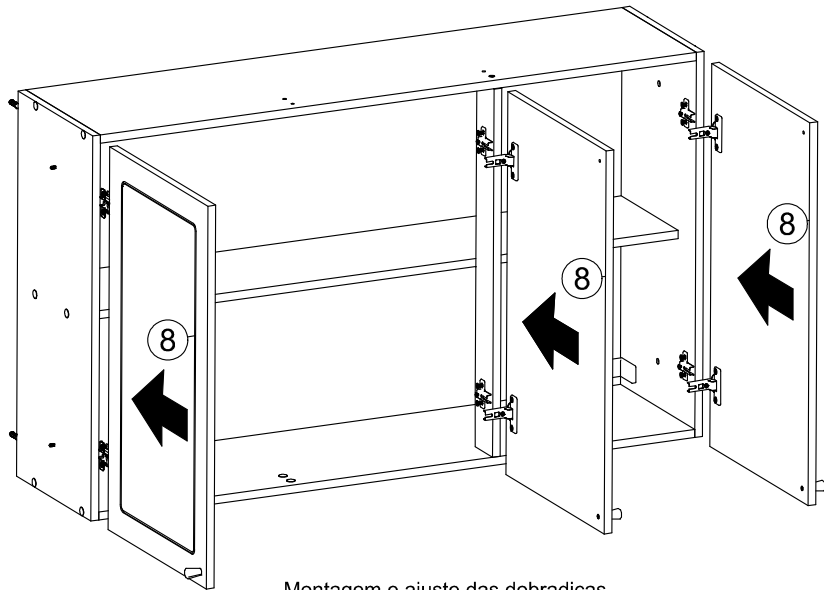
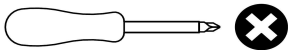

Montagem e ajuste das dobradiças.
Assembly and adjustment of the hinges.
Montaje y ajuste de las bisagras.

