

INSTRUÇÕES DE MONTAGEM

INSTRUCCIONES DE MONTAJE
ASSEMBLY INSTRUCTIONS

Cozinha Compacta 07 Emily | Cocina compacta 07 Emily |
Compact Kitchen 07 Emily

c CE191-05 Branco HP

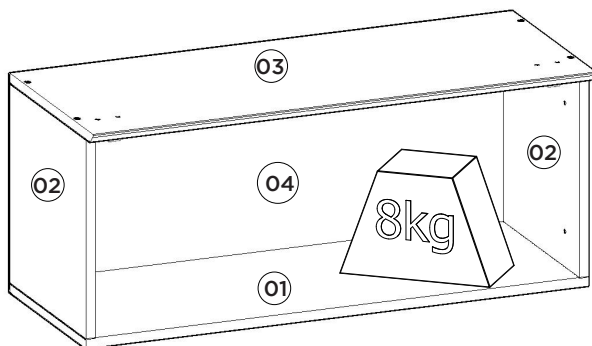
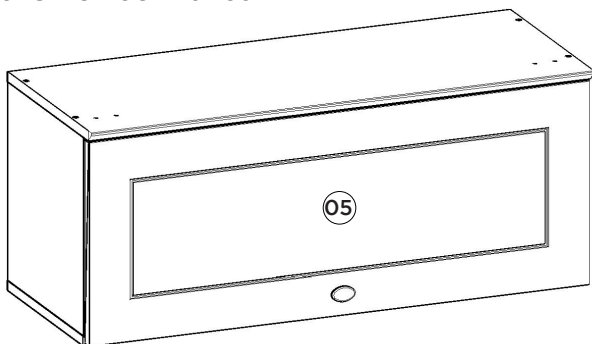

Pesos máximos recomendados com carga distribuída
Peso máximo recomendado con la carga distribuida
Recommended maximum weight with distributed load.

Requisitos para montagem
Requisitos para la montaje
Assembly Requirements

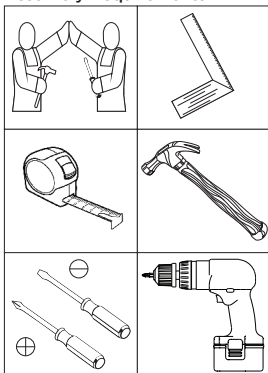

Imagens meramente ilustrativas
Imágenes meramente ilustrativas
Images for illustration only

AVISO

Para limpeza de seu móvel, use uma flanela seca ou umedecida, e não utilize produtos químicos que possam danificar seu produto.

SISTEMA DE MONTAGEM

O sistema de montagem dos produtos, funciona de acordo com a ordem crescente dos números indicados no desenho. Ex: 01, 02, 03, 04... até a conclusão da montagem.

ADVERTENCIA

Para limpieza de su móvil, use una franela seca o húmeda, y no utilice productos químicos que puedan dañar su producto.

SISTEMA DE MONTAJE

El sistema de montaje de los productos funciona de acuerdo con el orden creciente de los números indicados en el dibujo. Ej.: 01, 02, 03, 04... hasta la conclusión del montaje.

NOTICE

To clean your furniture, use a dry or wet cloth, and do not use chemicals that may damage your product.

ASSEMBLY SYSTEM

The products' assembly system works according to the increasing order of the indicated numbers. For example: 01, 02, 03, 04 ... to the end of the assembly.

1º

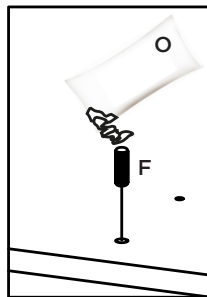
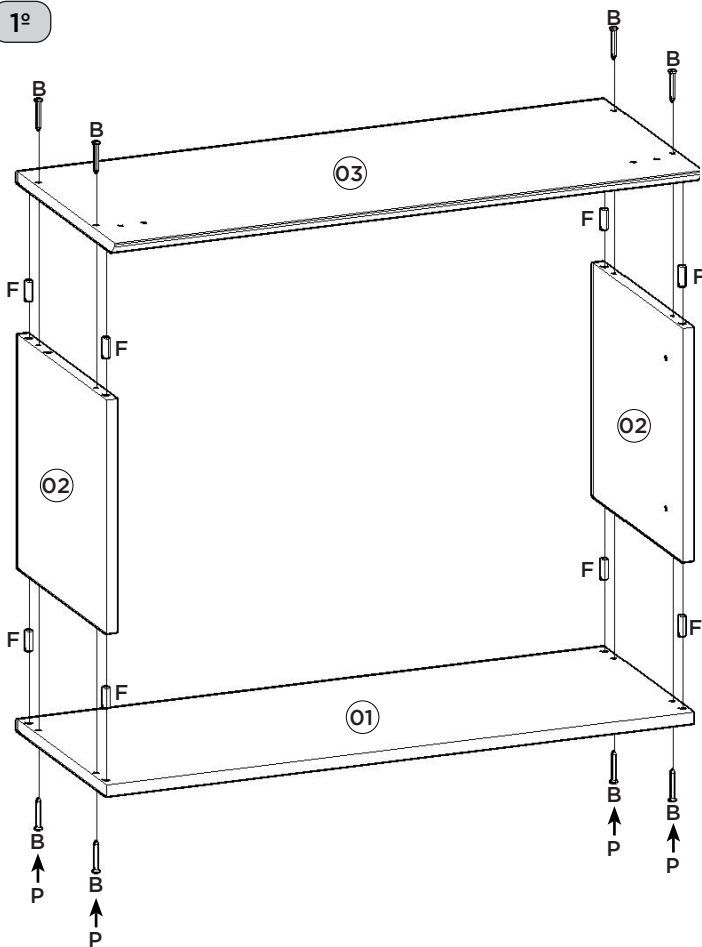

Utilizar o sachê de cola (O)
em todas as cavilhas (F)
do produto.

Con el pegamento sobre (O)
en todos los pernos (F)
producto.

Use the glue sachet (O) on all
the pegs (F) of the product.

2º

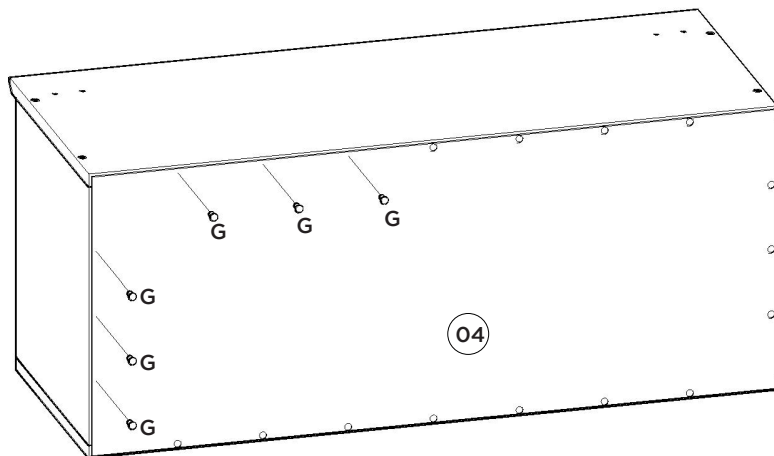

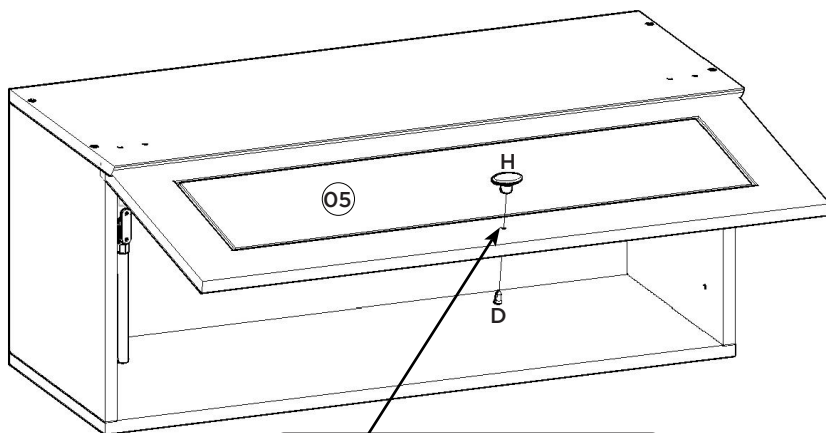

Para colocação do puxador, é necessário fazer a furação passante, com broca de 5mm.

Para colocar el mango, es necesario perforar con un taladro de 5 mm.



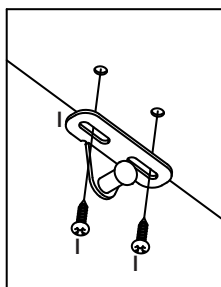
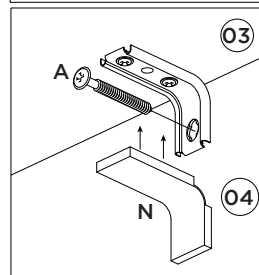
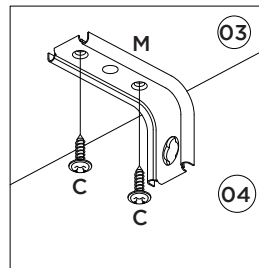
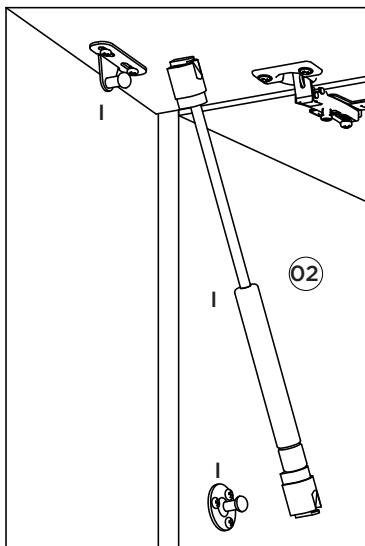
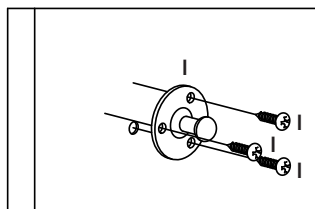
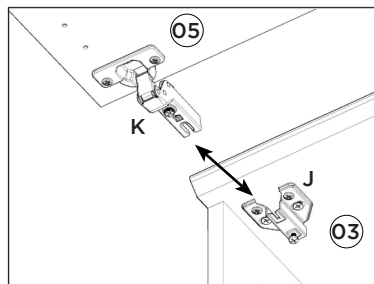
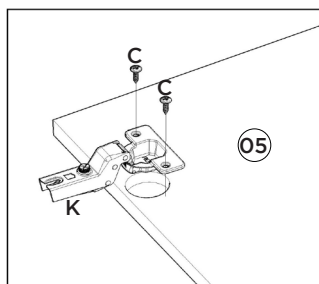
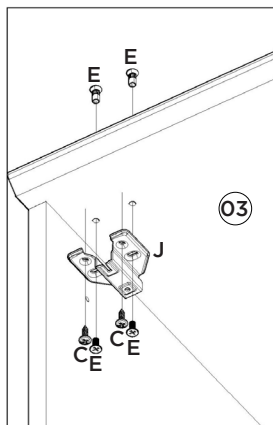











For placing the handle, it is necessary to drill through with a 5mm drill.

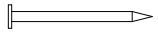

Lista de Peças | Lista de piezas | List of parts

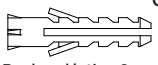
Item	Caixa Caja Box	Qtd Ctd Qty	Descrição Descripción Description	Medidas (mm) Dimensions (mm) Size (measurements) (mm)
01	1/1	01	Base Base Base	800x295x15
02	1/1	02	Lateral Direita Esquerda Lateral Derecha Izquierda Right Side Left	307x295x15
03	1/1	01	Tampo Tapa Top	800x322x15
04	1/1	01	Fundo Fondo Bottom	793x331x3
05	1/1	01	Porta Basculante Puerta Basculante Basculating Door	796x315x15

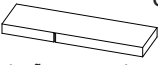
Ferragens | Herrajes | Hardware

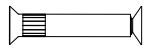
A  Parafuso 5,0x50mm FLA. Tornillo 5,0x50mm FLA. Screw 5,0x50mm FLA.	02x	B  Parafuso 3,5x40mm CHT. Tornillo 3,5x40mm CHT. Screw 3,5x40mm CHT.	08x	C  Parafuso 3,5x14mm FLA. Tornillo 3,5x14mm FLA. Screw 3,5x14mm FLA.	12x	D  Parafuso M4x20mm CHT. ZB Tornillo M4x20mm CHT. ZB Screw M4x20mm CHT. ZB	01x	E  Parafuso União 15mm Tornillo Unión 15mm Union Screw 15mm	04x
F  Cavilha 8x25mm Cinta 8x25mm Dowel 8x25mm	08x	G  Prego 10x10mm Clavo 10x10mm Nail 10x10mm	20x	H  Puxador Pontual PZ14 Oval Tirador Pontual PZ14 Oval PZ14 Oval Point Knob	01x	I  Kit Pistão a Gás 60N Kit Pistón a Gas 60N 60N Gas Piston Kit	01x	J  Calço Removível Calzado extraíble Removable Shim	02x
K  Dobradica SlideOn Super Alta Amort. 35mm Bisagra Super high amort de Slideon. 35mm Slideon Super High Amort hinge. 35mm	02x	L  Bucha plástica 8mm Bucha de plástico 8mm 8mm plastic bushing	02x	M  Suporte de fixação Soporte de fijación Mounting bracket	02x	N  Proteção para cantoneira Ángulo de protección Protection angle	02x	O  Sachê de cola Bolsa de pegamento Glue bag	01x
P  Adesivo tampa parafuso 10mm Adhesivo tapón de tornillo 10mm Bolt cover adhesive 10mm	08x	Q  Parafuso União 30mm Tornillo Unión 30mm Union Screw 30mm	04x						

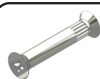

O parafuso (A) deve ser usada somente quando este módulo for acoplado a outro módulo componível Henn.



El tornillo (Q) se debe utilizar sólo cuando el módulo está conectado a otro módulo componible Henn.



The screw (Q) should be used only when this module is attached to another Henn modular module.

RECOMENDAÇÃO

Para fixar o móvel na parede usar o suporte de fixação (M), o parafuso 3,5x14mm FLA (C), a Bucha 8mm (L) e o parafuso 5,0x50mm FLA (A).

RECOMENDACIÓN

Para conectar el móvil a la pared con el soporte (M), tornillo 3,5 x14mm FLA (C), el casquillo de 8 mm (L) y el 5,0 x50mm tornillo FLA (A).

RECOMMENDATION

To fix the furniture to the wall use the fixing bracket (M), the 3.5x14mm FLA (C) screw, the 8mm bushing (L) and the 5.0x50mm FLA screw (A).

INSTRUÇÕES DE MONTAGEM

INSTRUCCIONES DE MONTAJE
ASSEMBLY INSTRUCTIONS

Requisitos para montagem
Requisitos para la montaje
Assembly Requirements

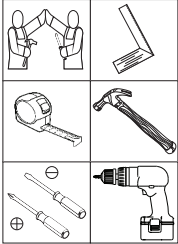

Imagens meramente ilustrativas
Imágenes meramente ilustrativas
Images for illustration only

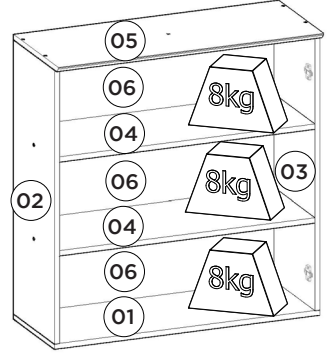
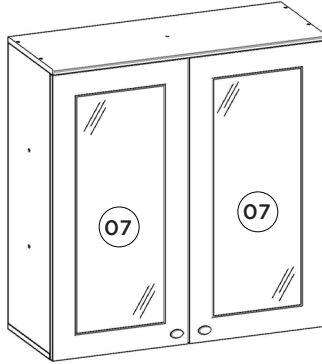

Pesos máximos recomendados com carga distribuída
Peso máximo recomendado con la carga distribuida
Recommended maximum weight with distributed load.

Lista de Peças | Lista de piezas | List of parts

Item	Caixa Caja Box	Qtd Ctd Qty	Descrição Descripción Description	Medidas (mm) Dimensiones (mm) Size (measurements) (mm)
01	1/1	01	Base Base Base	800x295x15
02	1/1	01	Lateral esquerda Lateral izquierdo Left side	800x295x15
03	1/1	01	Lateral Direita Lateral Derecha Right side	800x295x15
04	1/1	02	Prateleira Estante Shelf	769x295x15
05	1/1	01	Tampo Tapa Top	800x322x15
06	1/1	03	Fundo Fondo Bottom	792x274x3
07	1/1	02	Porta de Vidro Puerta de vidrio Glass door	813x396x15

Ferragens | Herrajes | Hardware

A 02x Parafuso 5,0x50mm FLA. Tornillo 5,0x50mm FLA. Screw 5,0x50mm FLA.	B 12x Parafuso 3,5x40mm CHT. Tornillo 3,5x40mm CHT. Screw 3,5x40mm CHT.	C 28x Parafuso 3,5x14mm FLA. Tornillo 3,5x14mm FLA. Screw 3,5x14mm FLA.	D 02x Parafuso M4x20mm CHT. ZB Tornillo M4x20mm CHT. ZB Screw M4x20mm CHT. ZB	E 16x Cavilha 8x25mm Cinta 8x25mm Dowel 8x25mm	F 04x Calço Removível Calzado extraíble Removable Shim
G 04x Dobradilha SlideOn Baixa Amortecedor 35mm Bisagra SlideOn Baja Amortiguador 35mm Low SlideOn Hinge 35mm Shock Absorber	H 02x Puxador Pontual PZ14 Oval Tirador Pontual PZ14 Oval PZ14 Oval Point Knob	I 02x Bucha plástica 8mm Bucha de plástico 8mm 8mm plastic bushing	J 02x Suporte de fixação Soporte de fijación Mounting bracket	K 02x Proteção para cantoneira Ángulo de protección Protection angle	L 04x Parafuso União 30mm Tornillo Unión 30mm Union Screw 30mm
M 02x Giz de correção Tiza de corrección Chalk of correction	N 01x Sachê de cola Bolsa de pegamento Glue bag	O 16x Adesivo tapa parafuso 10mm Adhesivo tapón de tornillo 10mm Bolt cover adhesive 10mm	P 14x Fixador de fundos Fijador de fondos Bottom fixer	Q 48x Prego 10x10mm Clavo 10x10mm Nail 10x10mm	R 01x Etiqueta resinada Henn Etiqueta resinada Henn Henn resin label

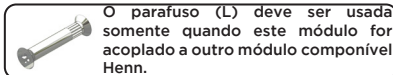

O parafuso (L) deve ser usada somente quando este módulo for acoplado a outro módulo componível Henn.

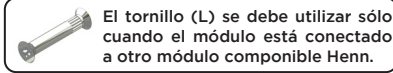

El tornillo (L) se debe utilizar sólo cuando el módulo está conectado a otro módulo componible Henn.

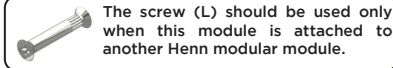

The screw (L) should be used only when this module is attached to another Henn modular module.

RECOMENDAÇÃO

Para fixar o móvel na parede usar o suporte de fixação (J), o parafuso 3,5x14mm FLA (C), a Bucha 8mm (I) e o parafuso 5,0x50mm FLA (A).

RECOMENDACIÓN

Para conectar el móvil a la pared con el soporte (J), tornillo 3,5 x14mm FLA (C), el casquillo de 8 mm (I) y el 5,0 x50mm tornillo FLA (A).

RECOMMENDATION

To fix the furniture to the wall use the fixing bracket (J), the 3.5x14mm FLA (C) screw, the 8mm bushing (I) and the 5.0x50mm FLA screw (A).

1º

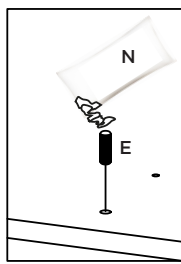
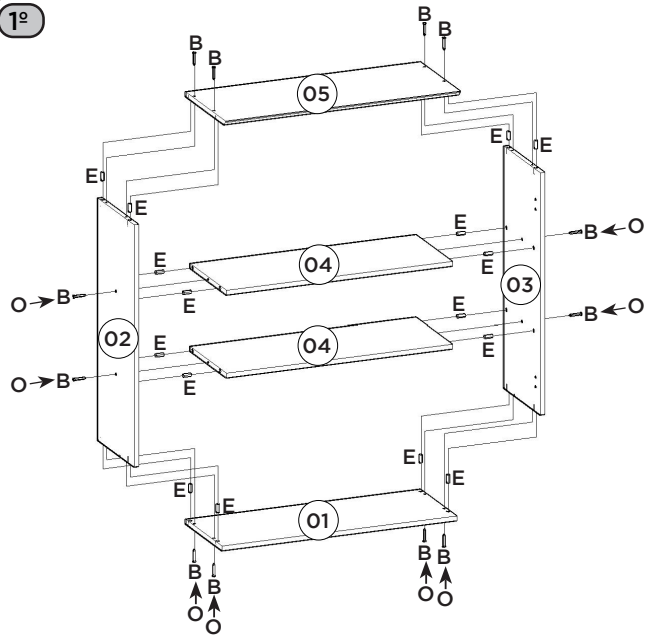

Utilizar o sachê de cola (N) em todas as cavilhas (E) do produto.

Con el pegamento sobre (N) en todos los pernos (E) producto.

Use the glue sachet (N) on all the pegs (E) of the product.

AVISO

Para limpeza de seu móvel, use uma flanela seca ou umedecida, e não utilize produtos químicos que possam danificar seu produto.

SISTEMA DE MONTAGEM

O sistema de montagem dos produtos, funciona de acordo com a ordem crescente dos números indicados no desenho. Ex: 01, 02, 03, 04... até a conclusão da montagem.

ADVERTENCIA

Para limpieza de su móvil, use una flanela seca o húmeda, y no utilice productos químicos que puedan dañar su producto.

SISTEMA DE MONTAJE

El sistema de montaje de los productos funciona de acuerdo con el orden creciente de los números indicados en el dibujo. Ej.: 01, 02, 03, 04... hasta la conclusión del montaje.

NOTICE

To clean your furniture, use a dry or wet cloth, and do not use chemicals that may damage your product.

ASSEMBLY SYSTEM

The products' assembly system works according to the increasing order of the indicated numbers. For example: 01, 02, 03, 04 ... to the end of the assembly.

2º

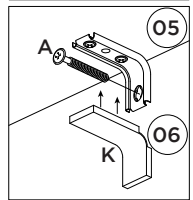
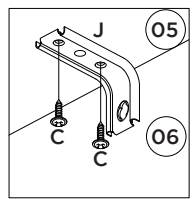
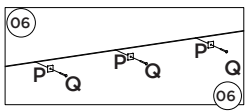
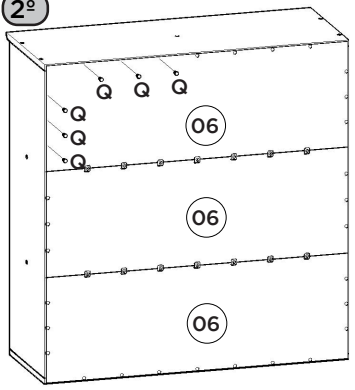

3º

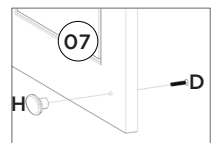
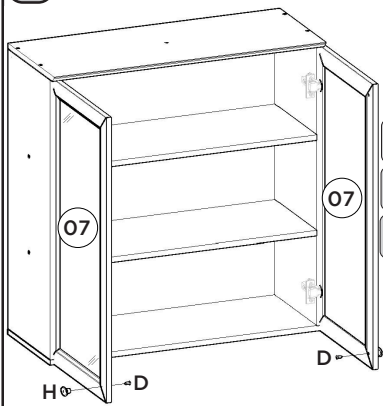

Para colocação dos puxadores, é necessário fazer a furação passante, com Broca de 5mm.

Para la colocación de las asas, es necesario perforar a través, con una broca de 5mm.

To place the handles is necessary to make the through hole, drill 5mm.

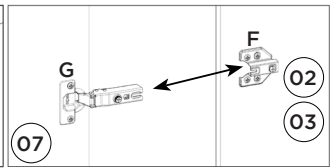
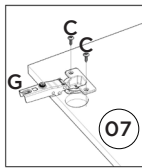
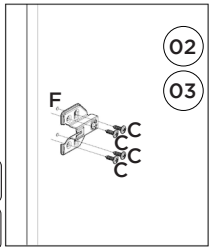

INSTRUÇÕES DE MONTAGEM

INSTRUCCIONES DE MONTAJE
ASSEMBLY INSTRUCTIONS

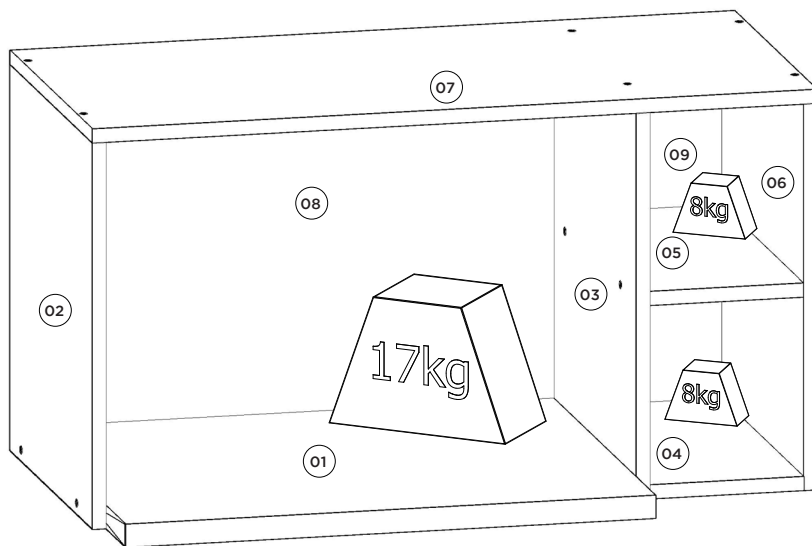

Pesos máximos recomendados com carga distribuída
Peso máximo recomendado con la carga distribuída
Recommended maximum weight with distributed load.

Requisitos para montagem Requisitos para la montaje Assembly Requirements

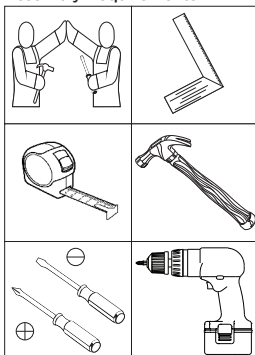

Imagens meramente ilustrativas
Imágenes meramente ilustrativas
Images for illustration only

AVISO

Para limpeza de seu móvel, use uma franela seca ou umedecida, e não utilize produtos químicos que possam danificar seu produto.

SISTEMA DE MONTAGEM

O sistema de montagem dos produtos, funciona de acordo com a ordem crescente dos números indicados no desenho. Ex: 01, 02, 03, 04... até a conclusão da montagem.

ADVERTENCIA

Para limpieza de su móvil, use una franela seca o húmeda, y no utilice productos químicos que puedan dañar su producto.

SISTEMA DE MONTAJE

El sistema de montaje de los productos funciona de acuerdo con el orden creciente de los números indicados en el dibujo. Ej.: 01, 02, 03, 04... hasta la conclusión del montaje.

NOTICE

To clean your furniture, use a dry or wet cloth, and do not use chemicals that may damage your product.

ASSEMBLY SYSTEM

The products' assembly system works according to the increasing order of the indicated numbers. For example: 01, 02, 03, 04 ... to the end of the assembly.

1º

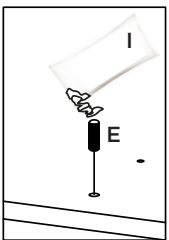
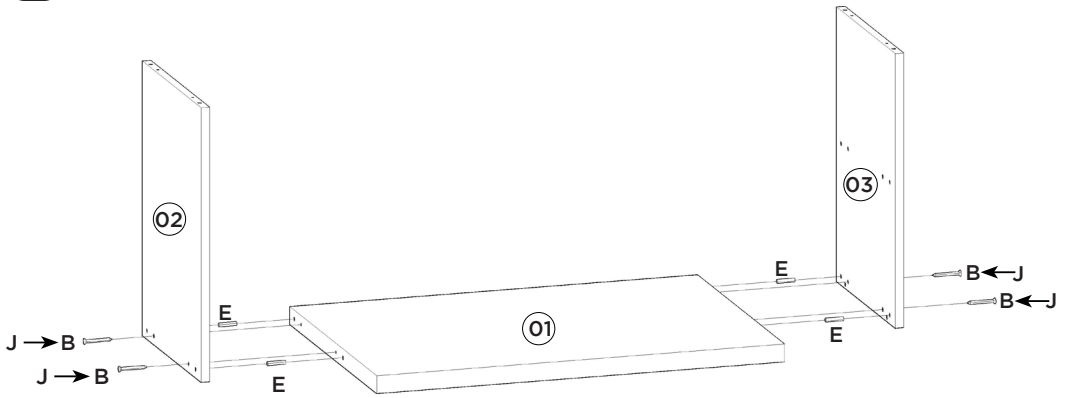

Utilizar o sachê de cola (I) em todas as cavilhas (E) do produto.

Con el pegamento sobre (U) en todos los pernos (E) producto.

Use the glue sachet (U) on all the pegs (E) of the product.

2º

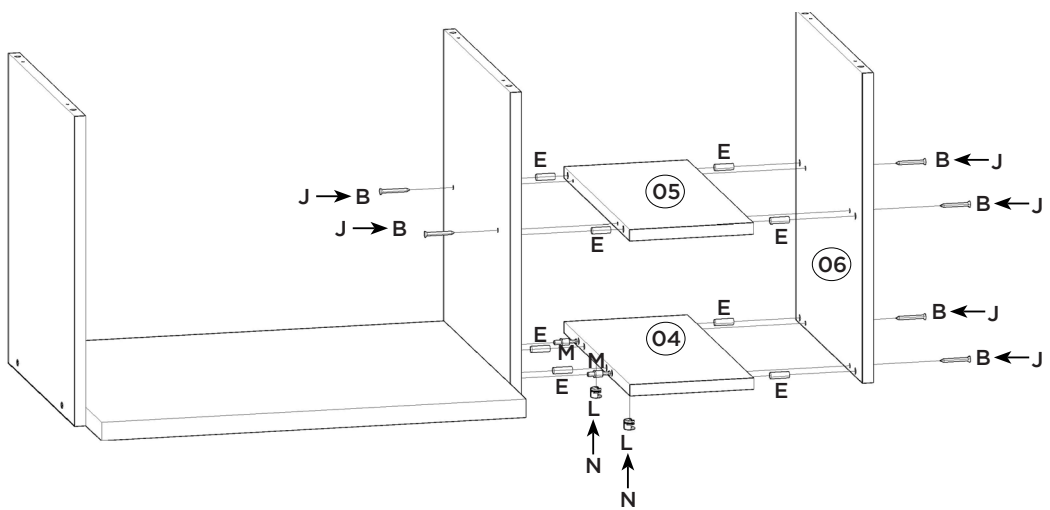

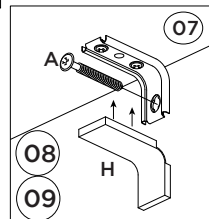
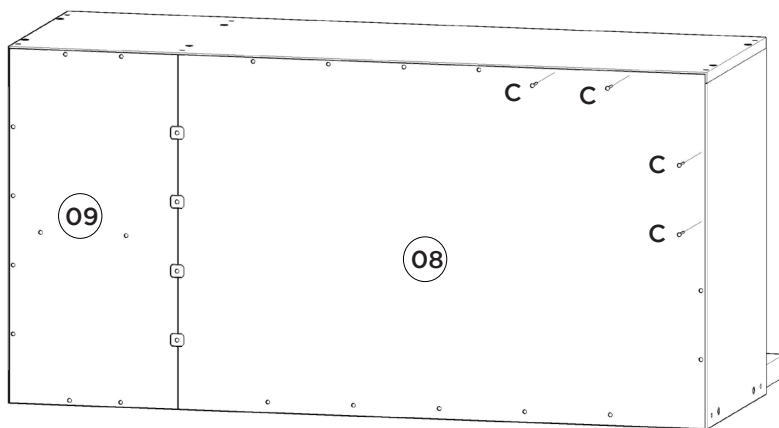
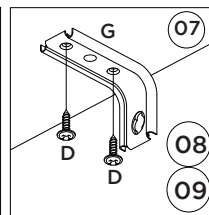
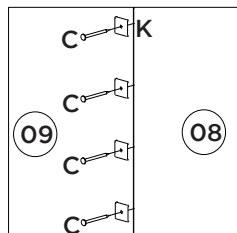
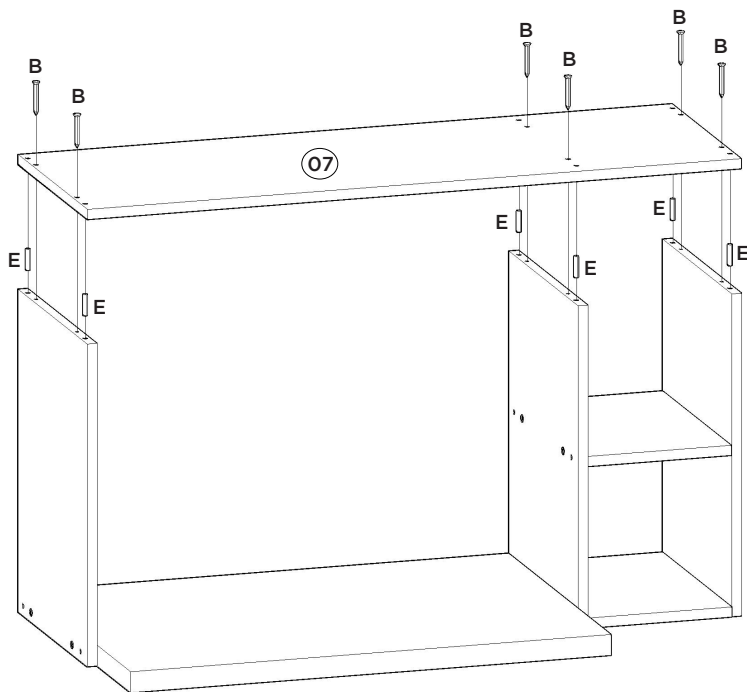







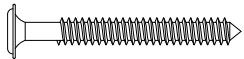

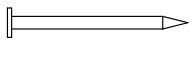

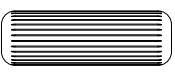
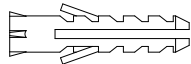

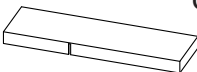

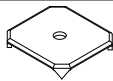
Lista de Peças | Lista de piezas | List of parts

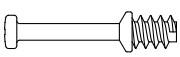
Item	Caixa Caja Box	Qty Ctd Qty	Descrição Descripción Description	Medidas (mm) Dimensions (mm) Size (measurements) (mm)
01	1/1	01	Base Base Base	585x470x25
02	1/1	01	Lateral Esquerda Lateral Izquierda Left Side	425x380x15
03	1/1	01	Divisão División Division	425x380x15
04	1/1	01	Base Menor Base más pequeña Smaller base	380x170x15
05	1/1	01	Prateleira Estante Shelf	378x170x15
06	1/1	01	Lateral Direita Lateral Derecha Side Left	425x380x15
07	1/1	01	Tampo Tapa Top	800x380x15
08	1/1	01	Fundo Fondo Bottom	604x434x3
09	1/1	01	Fundo Menor Fondo Menor Minor Fund	434x189x3

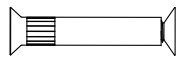
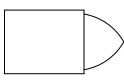
Ferragens | Herrajes | Hardware

A	03x	B	16x	C	30x	D	06x
							
Parafuso 5,0x50mm FLA. Tornillo 5,0x50mm FLA. Screw 5,0x50mm FLA.		Parafuso 3,5x40mm CHT. Tornillo 3,5x40mm CHT. Screw 3,5x40mm CHT.		Prego 10x10mm Clavo 10x10mm Nail 10x10mm		Parafuso 3,5x14mm FLA. Tornillo 3,5x14mm FLA. Screw 3,5x14mm FLA.	
E	18x	F	03x	G	03x	H	03x
							
Cavilha 8x25mm Cinta 8x25mm Dowel 8x25mm		Bucha plástica 8mm Bucha de plástico 8mm 8mm plastic bushing		Suporte de fixação Soporte de fijación Mounting bracket		Proteção para cantoneira Ángulo de protección Protection angle	
I	01x	J	14x	K	04x	L	02x
							
Sachê de cola Bolsa de pegamento Glue bag		Adesivo tapa parafuso 10mm Adhesivo tapón de tornillo 10mm Bolt cover adhesive 10mm		Fixador de fundos Fijador de fondos Bottom fixer		Tambor minifix Tambor minifix Minifix drum	
M	02x	N	02x	O	04x	P	02x
							
Parafuso minifix Tornillo minifix Minifix bolt		Adesivo tapa parafuso 17mm Adhesivo tapón de tornillo 17mm Bolt cover adhesive 17mm		Parafuso União 30mm Tornillo Unión 30mm Union Screw 30mm		Giz de correção Tiza de corrección Chalk of correction	

 O parafuso (O) deve ser usada somente quando este módulo for acoplado a outro módulo componível Henn.

 El tornillo (O) se debe utilizar sólo cuando el módulo está conectado a otro módulo componible Henn.

 The screw (O) should be used only when this module is attached to another Henn modular module.

RECOMENDAÇÃO

Para fixar o móvel na parede usar o suporte de fixação (G), o parafuso 3,5x14mm FLA (D), a Bucha 8mm (F) e o parafuso 5,0x50mm FLA (A).

RECOMENDACIÓN

Para conectar el móvil a la pared con el soporte (G), tornillo 3,5 x14mm FLA (D), el casquillo de 8 mm (F) y el 5,0 x50mm tornillo FLA (A).

RECOMMENDATION

To fix the furniture to the wall use the fixing bracket (G), the 3.5x14mm FLA (D) screw, the 8mm bushing (F) and the 5.0x50mm FLA screw (A).

INSTRUÇÕES DE MONTAGEM

INSTRUCCIONES DE MONTAJE
ASSEMBLY INSTRUCTIONS

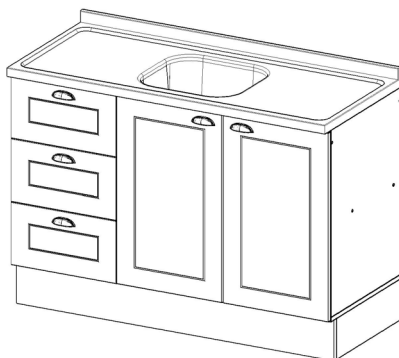
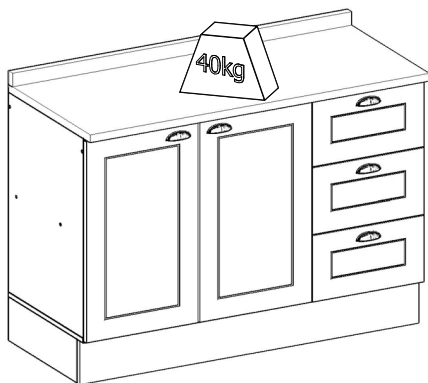
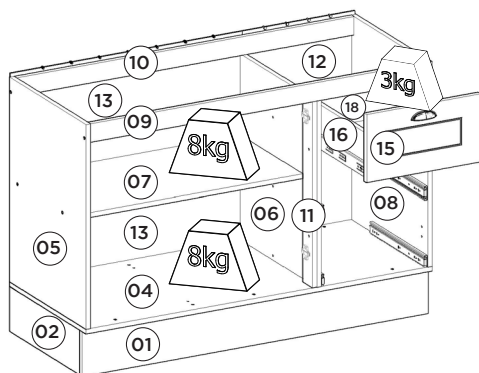
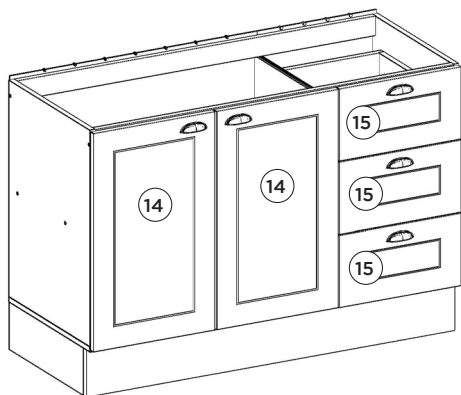

Pesos máximos recomendados com carga distribuída
Peso máximo recomendado con la carga distribuida
Recommended maximum weights with evenly distributed.

Requisitos para montagem
Requisitor para la montaje
Assembly Requirements

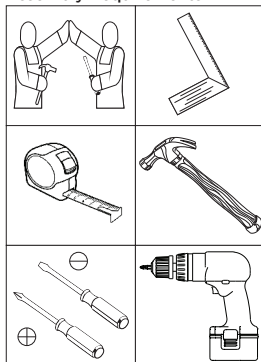

Imagens meramente ilustrativas
Imágenes meramente ilustrativas
Images for illustration only

AVISO

Para limpeza de seu móvel, use uma flanela seca ou umedecida, e não utilize produtos químicos que possam danificar seu produto.

SISTEMA DE MONTAGEM

O sistema de montagem dos produtos, funciona de acordo com a ordem crescente dos números indicados no desenho. Ex: 01, 02, 03, 04... até a conclusão da montagem.

ADVERTENCIA

Para limpieza de su móvil, use una flanela seca o húmeda, y no utilice productos químicos que puedan dañar su producto.

SISTEMA DE MONTAJE

El sistema de montaje de los productos funciona de acuerdo con el orden creciente de los números indicados en el dibujo. Ej.: 01, 02, 03, 04... hasta la conclusión del montaje.

NOTICE

To clean your furniture, use a dry or wet cloth, and do not use chemicals that may damage your product.

ASSEMBLY SYSTEM

The products' assembly system works according to the increasing order of the indicated numbers. For example: 01, 02, 03, 04 ... to the end of the assembly.

1º

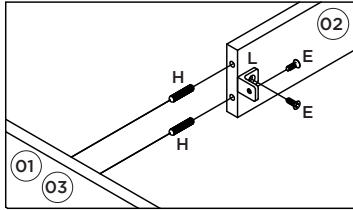
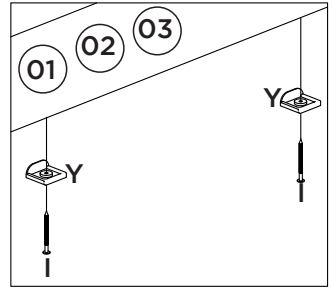
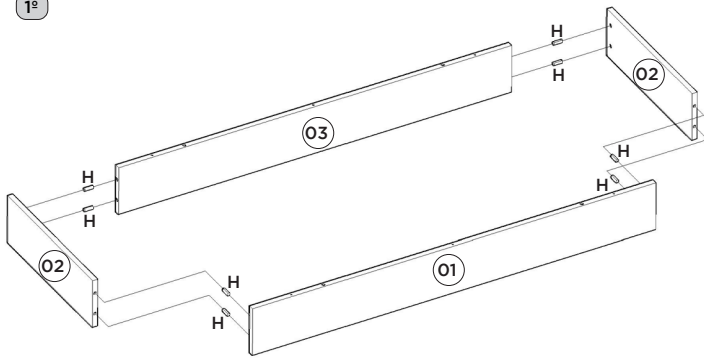

OPCIONAL:
 O945-121 Kit Pé Cônico 145mm
 (vendido separadamente). Caso
 opte em colocar pé no produto,
 utilizar as pré-furações que
 possui na Base e fixá-lo com o
 Parafuso que consta no Kit.

OPCIONAL:
 O945-121 Kit Pie Cónico 145mm
 (se vende por separado). Si
 opta por colocar pie en el pro-
 ducto, utilizar las pre-huracuras
 que tenga en la Base y fijarlo
 con el Tornillo que consta en
 el Kit.

OPTIONAL:
 O945-121 Tapered Foot Kit
 145mm (sold separately). If you
 choose to put foot in the prod-
 uct, use the pre-drillings in the
 Base and fix it with the Screw
 included in the Kit.

2º

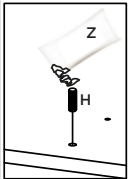

Utilizar o sachê de cola (Z) em todas
 as cavilhas (H) do produto.

Con el pegamento sobre (Z) en
 todos los pernos (H) producto.

Use the glue sachet (Z) on all the
 pegs (H) of the product.

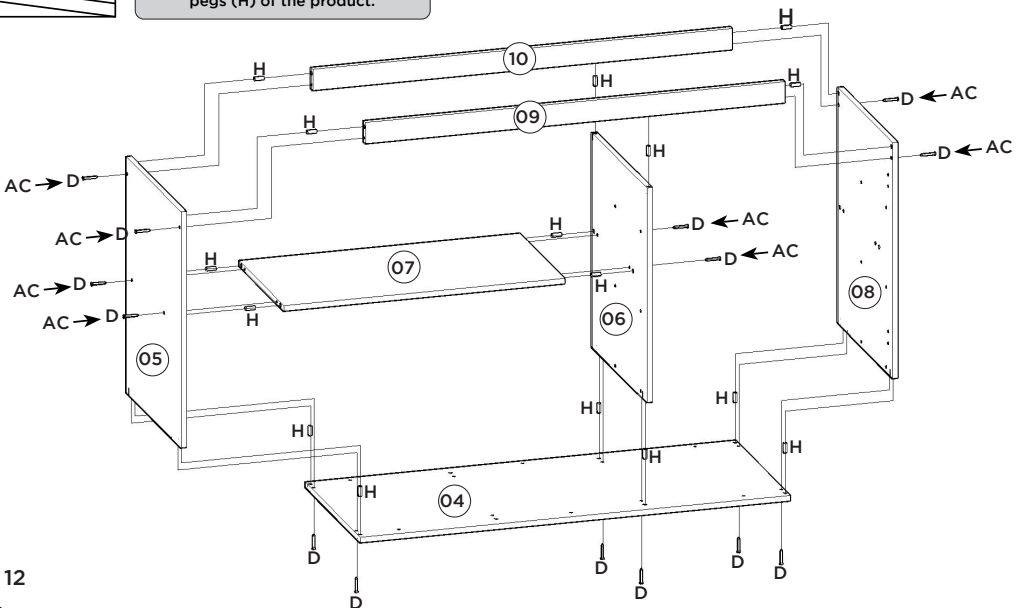

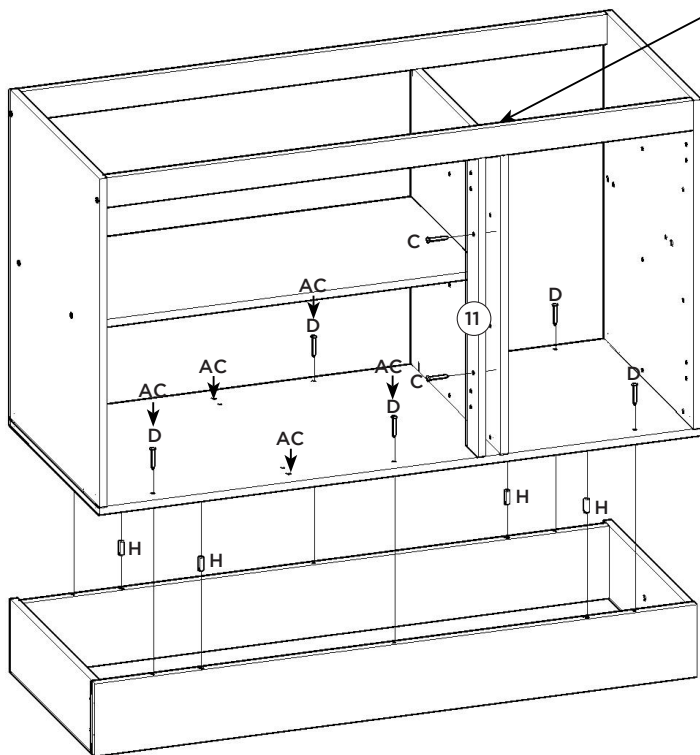
3^o

A pilastra da porta (11) deve estar alinhada com a divisão (06).

El pilar de la puerta (11) debe estar alineada con la división (06).

The door pillar (11) must be aligned with the partition (06).

4^o

Esse tampo é opcional e é vendido separadamente (C905-114).

Esta vez es opcional y se vende por separado (C905-114).

This top is optional and is sold separately (C905-114).

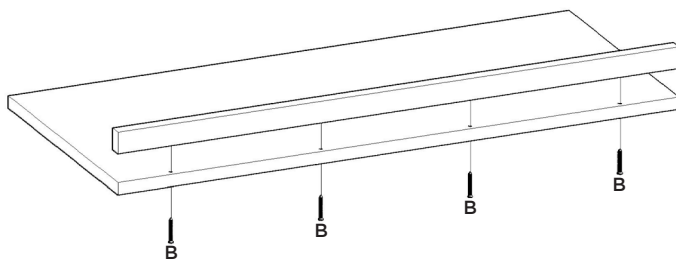

5°

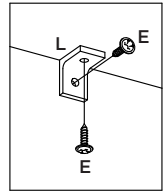
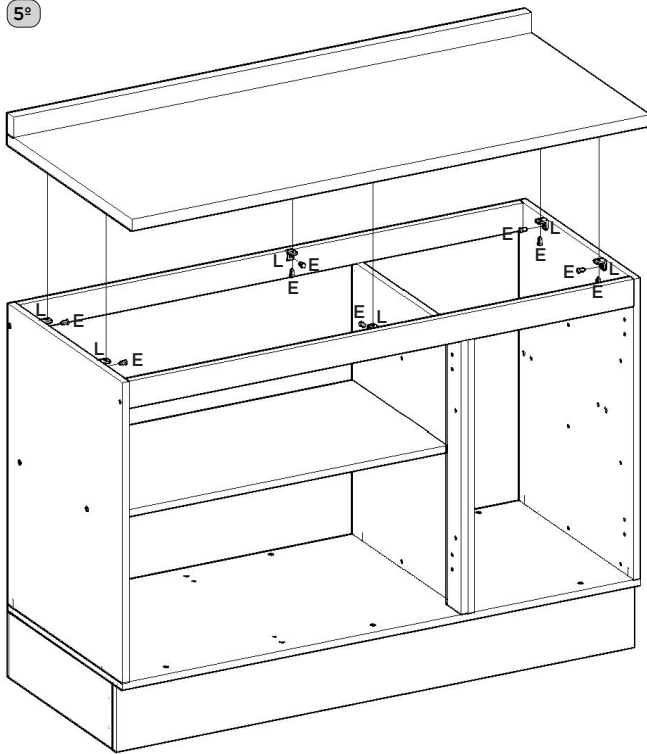

Caso o móvel seja montado com a opção do tampo, fixar o mesmo com 06 cantoneiras (L) e os parafusos 3,5x14mm (E).

Si se monta el auricular con la opción de la cubierta, fijarlo con Los ángulos 06 (L) y 3,5 x14mm tornillos (E).

If the furniture is to be installed with the top cover option, fix it with 06 (L) and 3.5x14mm screws (E).

6°

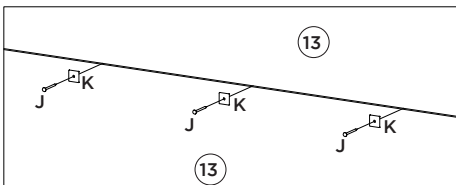
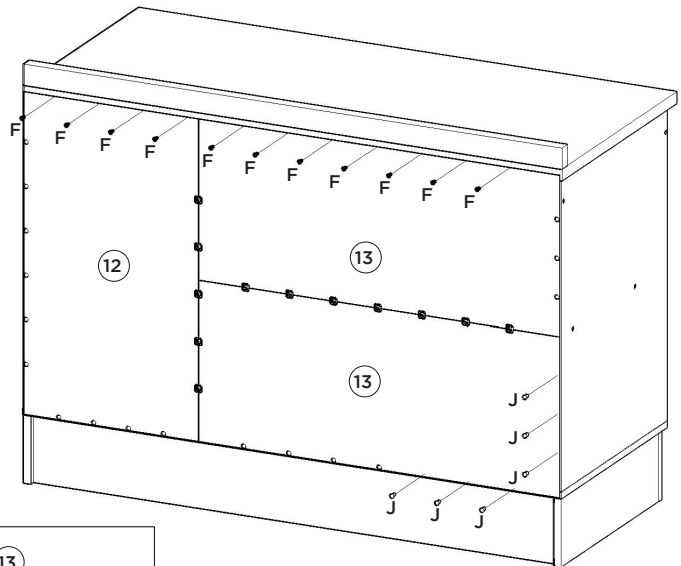
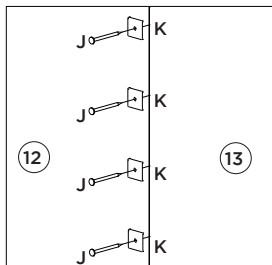

7º

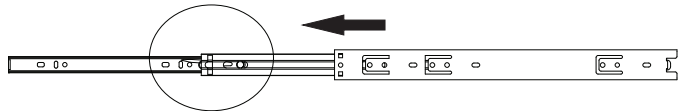
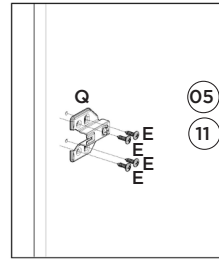
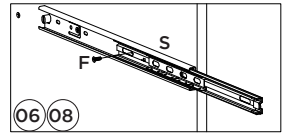
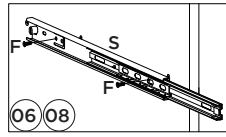
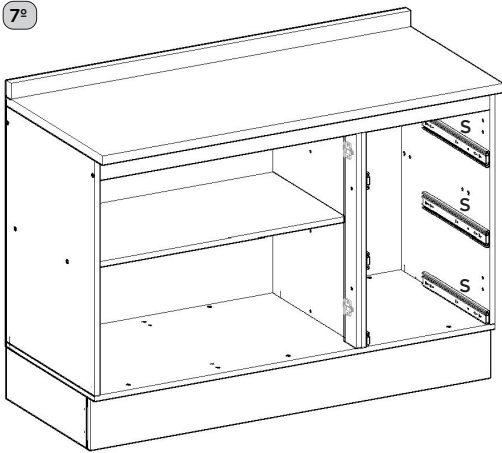

Para a desmontagem da correia siga a instrução ao lado.

Para el desmontaje seguimiento de diapositivas la instrucción siguiente a.

For the dismount of the sliding onem follows the instruction aside.

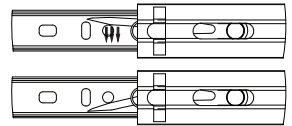

Fixar as correias nessas furações
Fijar las diapositivas de estos agujeros
Fix slides in these drillings

8º

Opção Suspensa

Opción suspendida

Suspended Option

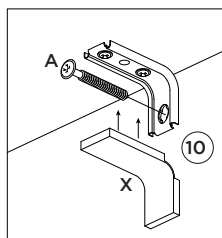
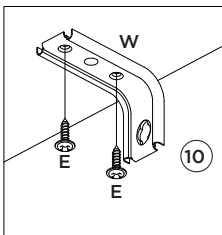

Pare-
de
pared
Wall

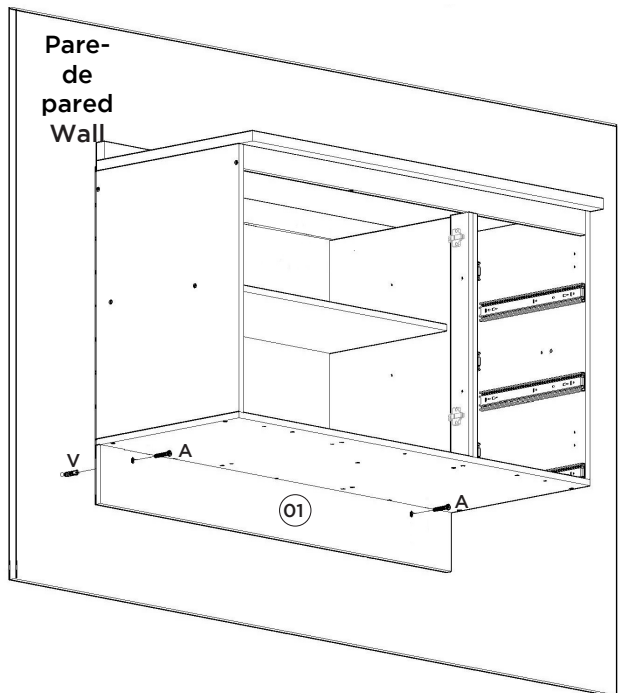

15

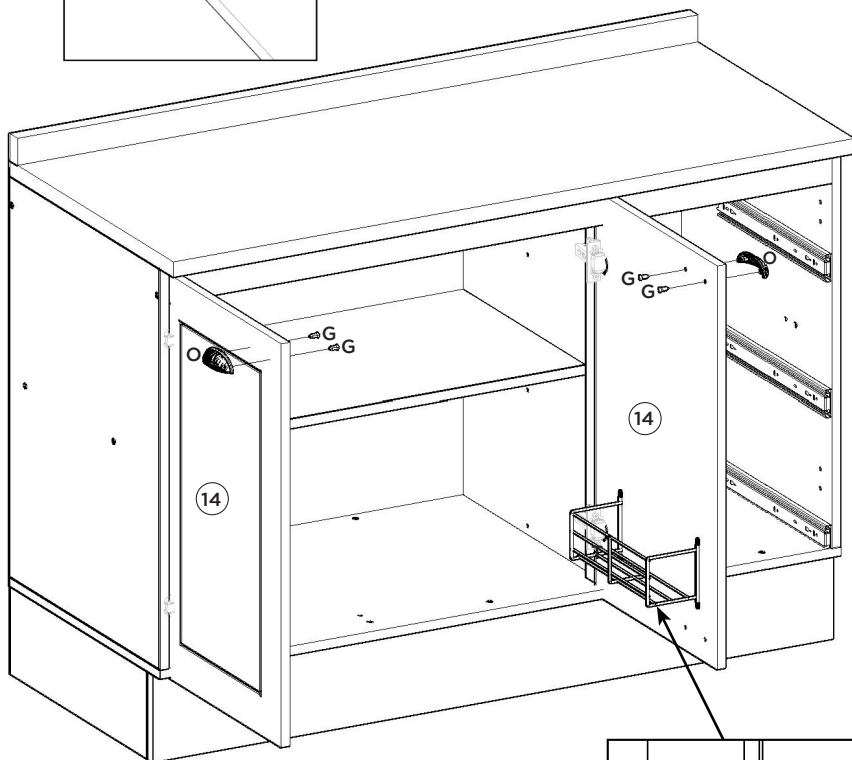
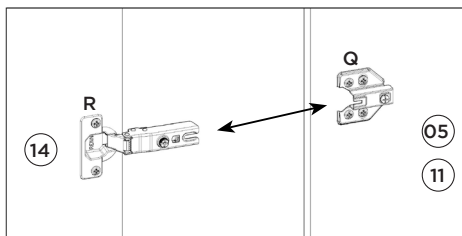
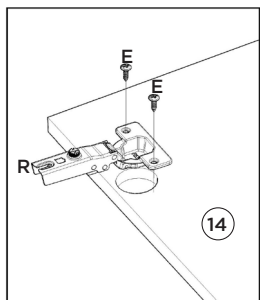

Para colocação dos puxadores, é necessário fazer a furação passante, com Broca de 5mm.

Para la colocación de las asas, es necesario perforar a través, con una broca de 5mm.

To place the handles is necessary to make the through hole, drill 5mm.

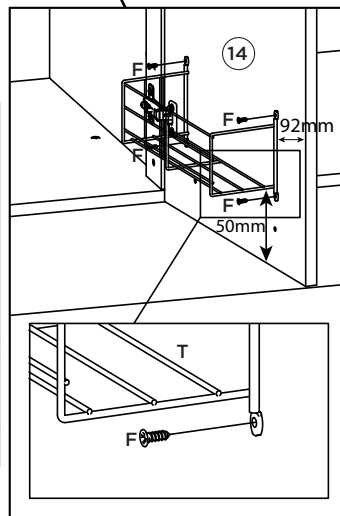
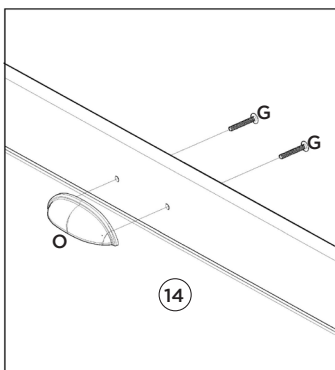

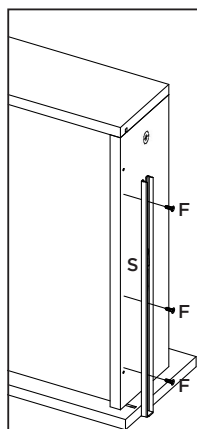
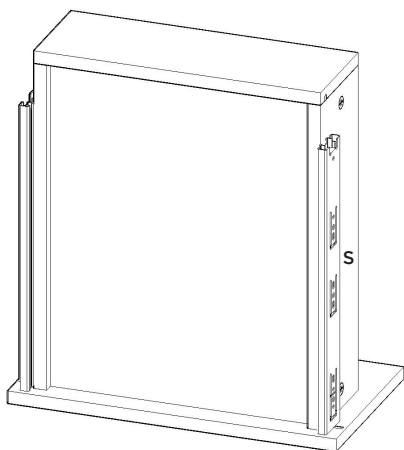
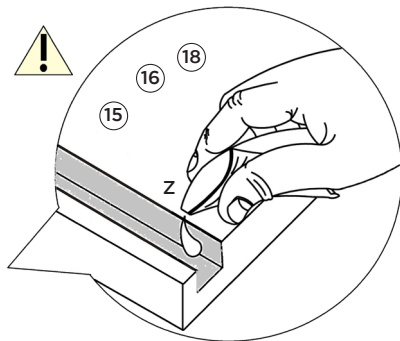
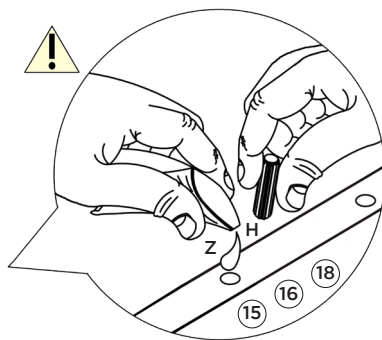
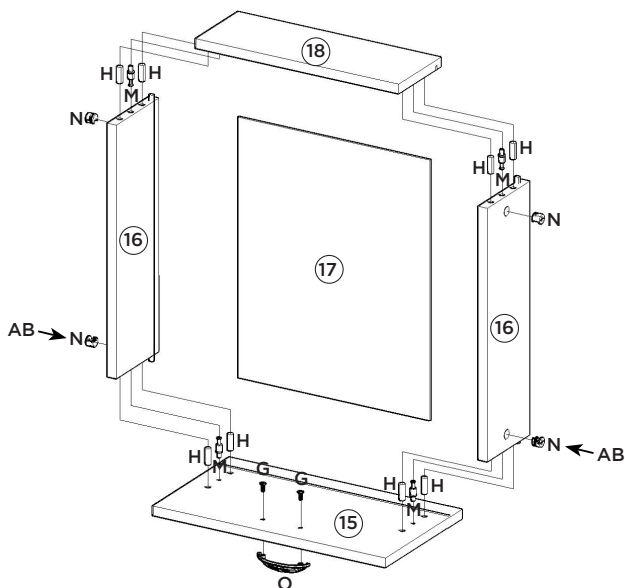

A corrediça (S) deverá ser alinhada com a parte de baixo do lado de gaveta (16).











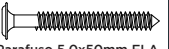

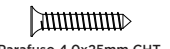
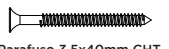
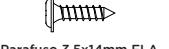
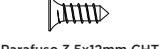



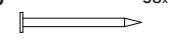

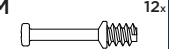

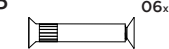



La carcasa (S) será alineada con la parte de por el lado del cajón (16).

The slide (S) should be aligned with the underside of the drawer side (16).

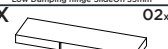
Lista de Peças | Lista de piezas | List of parts

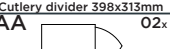
Item	Caixa Caja Box	Qtd Ctd Qty	Descrição Descripción Description	Medidas (mm) Dimensions (mm) Size (measurements) (mm)
01	1/1	01	Rodapé Frontal Frente pie de página Front Footer	1200x145x15
02	1/1	02	Rodapé Lateral Pie de página Side Side Footer	450x145x15
03	1/1	01	Rodapé Traseiro Pie de página trasera Rear Footer	1168x145x15
04	1/1	01	Base Base Base	1200x490x15
05	1/1	01	Lateral esquerda Lateral izquierda Left side	660x490x15
06	1/1	01	Divisão División Division	600x490x15
07	1/1	01	Prateleira Estante Shelf	784x400x15
08	1/1	01	Lateral direita Lateral derecha Right side	660x490x15
09	1/1	01	Travessa frontal Travesaño frontal Front crossbar	1169x60x15
10	1/1	01	Travessa traseira Travesaño trasero Rear bumper	1169x60x15
11	1/1	01	Pilastra da Porta Pilastra Puerta Pilaster door	599x60x15
12	1/1	01	Fundo Lateral Fondo Lateral Lateral Background	683x389x3
13	1/1	02	Fundo Fondo Bottom	803x341x3
14	1/1	02	Porta Puerta Door	665x396x15
15	1/1	03	Frente de gaveta Frente de cajón Front of drawer	396x220x15
16	1/1	06	Lado de Gaveta Lado del cajón Drawer Side	400x122x15
17	1/1	03	Fundo de gaveta Fondo de cajón Bottom of drawer	411x326x3
18	1/1	03	Ripa de trás Malla detrás Rear lath	345x122x15

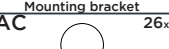
Ferragens | Herrajes | Hardware

A  Parafuso 5,0x50mm FLA. Tornillo 5,0x50mm FLA. Screw 5,0x50mm FLA.	B  Parafuso 4,5x50mm CHT. Tornillo 4,5x50mm CHT. Screw 4,5x50mm CHT.	C  Parafuso 4,0x25mm CHT. Tornillo 4,0x25mm CHT. Screw 4,0x25mm CHT.	D  Parafuso 3,5x40mm CHT. Tornillo 3,5x40mm CHT. Screw 3,5x40mm CHT.	E  Parafuso 3,5x14mm FLA. Tornillo 3,5x14mm FLA. Screw 3,5x14mm FLA.	F  Parafuso 3,5x12mm CHT. Tornillo 3,5x12mm CHT. Screw 3,5x12mm CHT.
G  Parafuso M4x20mm CHT. ZB. Tornillo M4x20mm CHT. ZB. Screw M4x20mm CHT. ZB.	H  Cavilha 8x25mm Cinta 8x25mm Dowel 8x25mm	I  Prego 12x12mm Anelado Clavo 12x12mm Anilado Ringed Nails 12x12mm	J  Prego 10x10mm Clavo 10x10mm Nail 10x10mm	K  Fixador de fundos Fijador de fondos Bottom fixer	L  Cantoneira plástica Cantonera plástica Plastic angle brackets
M  Parafuso minifix Tornillo minifix Minifix bolt	N  Tambor minifix Tornillo minifix Minifix drum	O  Puxador Concha Tirador Concha Shell Handle	P  Parafuso União 30mm Tornillo Unión 30mm Union Screw 30mm	Q  Calço Removível Calzado extraíble Removable Shim	R  Dobradica SlideOn Baixa Amortecimento 35mm Bisaagra SlideOn Baja Amortiguación 35mm Low Damping Hinge SlideOn 35mm
S  Corrediza telescópica Diapositivas telescópicas Telescopic slides	T  Porta detergente 256x91mm Puerta detergente 256x91mm Detergent door 256x91mm	U  Divisor talheres 398x313mm Divisor cubiertos 398x313mm Cutlery divider 398x313mm	V  Bucha plástica 8mm Bucha de plástico 8mm 8mm plastic bushing	W  Suporte de fixação Soporte de fijación Mounting bracket	X  Proteção para cantoneira Ángulo de protección Protection angle
Y  Sapata "L" 16x20mm Zapata "L" 16x20mm "L" shoe 16x20mm	Z  Sachê de cola Bolsa de pegamento Glue bag	AA  Giz de correção Tiza de corrección Chalk of correction	AB  Adesivo tapa parafuso 17mm Adhesivo tapón de tornillo 17mm Bolt cover adhesive 17mm	AC  Adesivo tapa parafuso 10mm Adhesivo tapón de tornillo 10mm Bolt cover adhesive 10mm	AD  Etiqueta resinada Henn Etiqueta resinada Henn Henn resin label

 O parafuso (P) deve ser usada somente quando este módulo for acoplado a outro módulo componível Henn.

 El tornillo (P) se debe utilizar sólo cuando el módulo está conectado a otro módulo componible Henn.

 The screw (P) should be used only when this module is attached to another Henn modular module.

RECOMENDAÇÃO

Para fixar o móvel na parede usar o suporte de fixação (W), o parafuso 3,5x14mm FLA (E), a Bucha 8mm (V) e o parafuso 5,0x50mm FLA (A).

RECOMENDACIÓN

Para conectar el móvil a la pared con el soporte (W), tornillo 3,5 x14mm FLA (E), el casquillo de 8 mm (V) y el 5,0 x50mm tornillo FLA (A).

RECOMMENDATION

To fix the furniture to the wall use the mounting bracket (W), the 3.5x14mm FLA (E) screw, the 8mm bushing (V) and the 5.0x50mm FLA (A).

INSTRUÇÕES DE MONTAGEM

INSTRUCCIONES DE MONTAJE ASSEMBLY INSTRUCTIONS



Requisitos para montagem
Requisitor para la montaje
Assembly Requirements

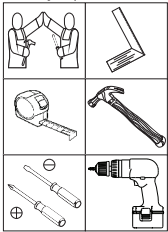

Imagens meramente ilustrativas
Imágenes meramente ilustrativas
Images for illustration only

OPCIONAL:
O944-121 Kit Pé Cônico 145mm (vendido separadamente). Caso opte em colocar pé no produto, utilizar as pré-furações que possui na Base e fixá-lo com o Parafuso que consta no Kit.

OPCIONAL:
O944-121 Kit Pie Cónico 145mm (se vende por separado). Si opta por colocar pie en el producto, utilizar las pre-furaduras que tenga en la Base y fijarlo con el Tornillo que consta en el Kit.

OPTIONAL:
O944-121 Tapered Foot Kit 145mm (sold separately). If you choose to put foot in the product, use the pre-drillings in the Base and fix it with the Screw included in the Kit.

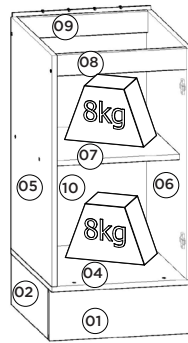
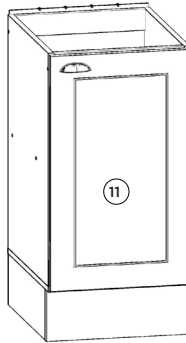

Pesos máximos recomendados com carga distribuída
Peso máximo recomendado con la carga distribuída
Recommended maximum weights with evenly distributed.

Lista de Peças | Lista de piezas | List of parts

Item	Caixa Caja Box	Qtd Ctd Qty	Descrição Descripción Description	Medidas (mm) Dimensions (mm) Size (measurements) (mm)
01	1/1	01	Rodapé Frontal Frente pie de página Front Footer	400x145x15
02	1/1	02	Rodapé Lateral Pie de página Side Side Footer	450x145x15
03	1/1	01	Rodapé Traseiro Pie de página trasera Rear Footer	368x145x15
04	1/1	01	Base Base Base	400x490x15
05	1/1	01	Lateral esquerda Lateral izquierda Left side	660x490x15
06	1/1	01	Lateral direita Lateral derecha Right side	660x490x15
07	1/1	01	Prateleira Estante Shelf	369x400x15
08	1/1	01	Travessa frontal Travesaño frontal Front crossbar	369x60x15
09	1/1	01	Travessa traseira Travesaño trasero Rear bumper	369x60x15
10	1/1	01	Fundo Fondo Bottom	684x392x3
11	1/1	01	Porta Puerta Door	665x396x15

AVISO

Para limpeza de seu móvel, use uma flanela seca ou umedecida, e não utilize produtos químicos que possam danificar seu produto.

SISTEMA DE MONTAGEM

O sistema de montagem dos produtos, funciona de acordo com a ordem crescente dos números indicados no desenho. Ex: 01, 02, 03, 04... até a conclusão da montagem.

ADVERTENCIA

Para limpieza de su móvil, use una flanela seca o húmeda, y no utilice productos químicos que puedan dañar su producto.

SISTEMA DE MONTAJE

El sistema de montaje de los productos funciona de acuerdo con el orden creciente de los números indicados en el dibujo. Ej: 01, 02, 03, 04... hasta la conclusión del montaje.

NOTICE

To clean your furniture, use a dry or wet cloth, and do not use chemicals that may damage your product.

ASSEMBLY SYSTEM

The products' assembly system works according to the increasing order of the indicated numbers. For example: 01, 02, 03, 04... to the end of the assembly.

Ferragens | Herrajes | Hardware

A	04:	B	02:	C	15:	D	32:	E	04:	F	02:	G	04:	H	24:
Parafuso 5,0x50mm FLA Tornillo 5,0x50mm FLA Screw 5,0x50mm FLA	Parafuso 4,5x50mm CHT. Tornillo 4,5x50mm CHT. Screw 4,5x50mm CHT.	Parafuso 3,5x40mm CHT. Tornillo 3,5x40mm CHT. Screw 3,5x40mm CHT.	Parafuso 3,5x14mm FLA. Tornillo 3,5x14mm FLA. Screw 3,5x14mm FLA	Parafuso 3,5x12mm CHT. Tornillo 3,5x12mm CHT. Screw 3,5x12mm CHT.	Parafuso M4x20mm CHT. ZB Tornillo M4x20mm CHT. ZB Screw M4x20mm CHT. ZB	Parafuso União 30mm Tornillo Union 30mm Union Screw 30mm	Cavilha 8x25mm Cinta 8x25mm Dowel 8x25mm	Pregos 10x10mm Clavos 10x10mm Nail 10x10mm	Sapata "L" 16x20mm Zapata "L" 16x20mm "L" shoe 16x20mm	Cantoneira plástica Cantenera plástica Plastic angle brackets	Puxador Concha Tirador Concha Shell Handle	Calço Removível Calzado extraíble Removable Shim	Bucha Slide-On Baja Amortiguador 25mm Bushing Slide-On Baja Amortiguador 25mm Low Shock On Hinge Shim Shock Absorber	Bucha plástica 8mm Bucha de plástico 8mm 8mm plastic bushing	Suporte de fixação Soporte de fijación Mounting bracket
Proteção para cantoneira Ángulo de protección Protection angle	Giz de correção Tiza de corrección Chalk of correction	Sachê de cola Bolsa de pegamento Glue bag	Adesivo tapa parafuso 10mm Adhesivo tapón de tornillo 10mm Bolt cover adhesive 10mm	Pregos 12x12mm Anelado Clavos 12x12mm Anillado Rimmed Nails 12x12mm											



O parafuso (G) deve ser usada somente quando este módulo for alocado a outro módulo componível Henn.



El tornillo (G) se debe utilizar sólo cuando el módulo está conectado a otro módulo componible Henn.



The screw (G) should be used only when this module is attached to another Henn modular module.

RECOMENDAÇÃO

Para fixar o móvel na parede usar o suporte de fixação (P), o parafuso 3,5x14mm FLA (D), a Bucha 8mm (O) e o parafuso 5,0x50mm FLA (A).

RECOMENDACIÓN

Para conectar el móvil a la pared con el soporte (P), tornillo 3,5 x14mm FLA (D), el casquillo de 8 mm (O) y el 5,0 x50mm tornillo FLA (A).

RECOMMENDATION

To fix the furniture to the wall use the mounting bracket (P), the 3.5x14mm FLA (D) screw, the 8mm bushing (O) and the 5.0x50mm FLA (A).

1º

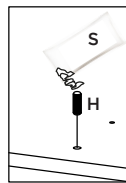
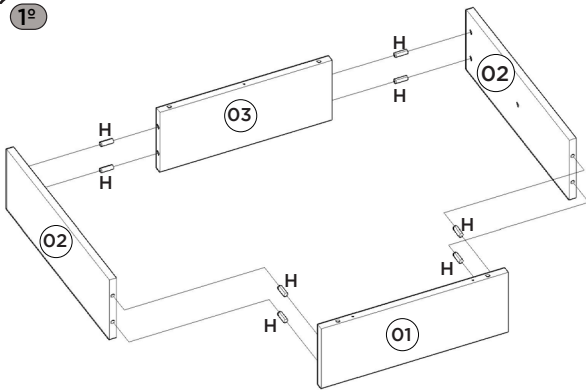

Utilizar o sachê de cola (S) em todas as cavilhas (H) do produto.

Con el pegamento sobre (S) en todos los pernos (H) producto.

Use the glue sachet (S) on all the pegs (H) of the product.

2º

Esse tampo é opcional e é vendido separadamente (C902-114).

Esta vez es opcional y se vende por separado (C902-114).

This top is optional and is sold separately (C902-114).

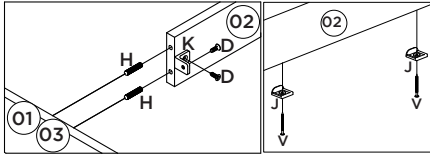
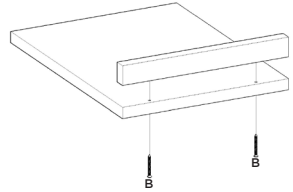

3º

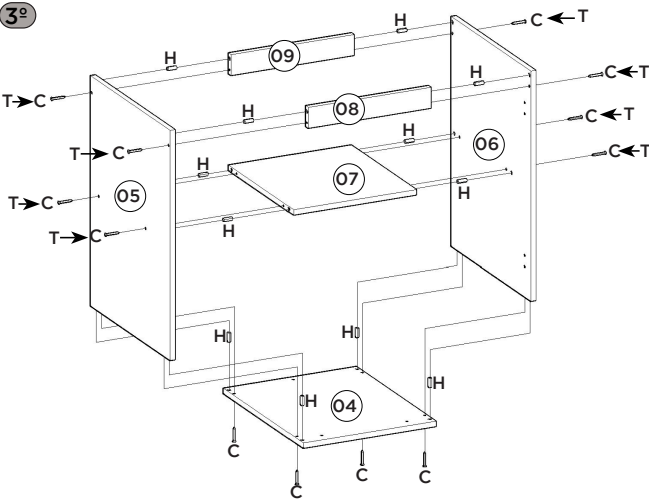

4º

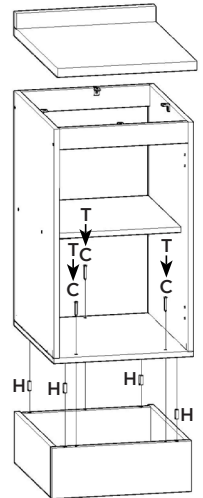
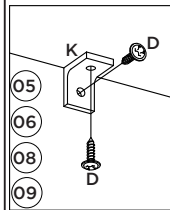

5º

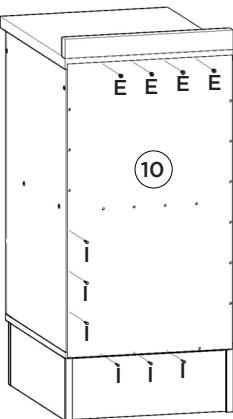

6º

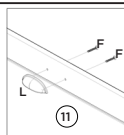

Para colocação do puxador, é necessário fazer a furação passante, com broca de 5mm.

Para colocar el mango, es necesario perforar con un taladro de 5 mm.

For placing the handle, it is necessary to drill through with a 5mm drill.

Opção Suspensa

Opción suspendida

Suspended Option

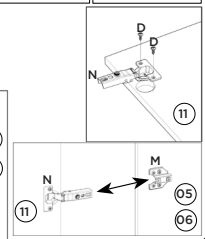
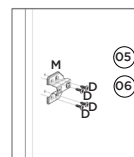
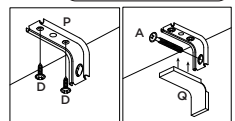
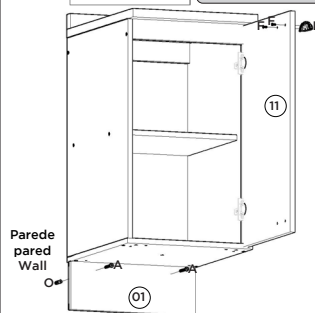

20

INSTRUÇÕES DE MONTAGEM

INSTRUCCIONES DE MONTAJE
ASSEMBLY INSTRUCTIONS

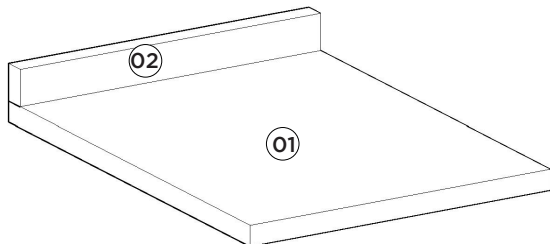

Requisitos para montagem
Requisitor para la montaje
Assembly Requirements

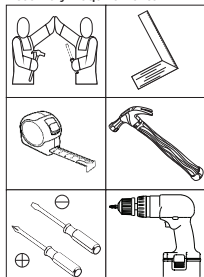

Imagens meramente ilustrativas
Imágenes meramente ilustrativas
Images for illustration only

Lista de Peças | Lista de piezas | List of parts

Item	Caixa Caja Box	Qty Ctd Qty	Descrição Descripción Description	Medidas (mm) Dimensiones (mm) Size (measure- ments) (mm)
01	1/1	01	Tampo Tapa Top	533x400x25
02	1/1	01	Rodatampo Rodatampo Rodatampo	400x45x25

Ferragens | Herrajes | Hardware

A	02x	B	08x	C	04x
					
Parafuso 4,5x50mm CHT. Tornillo 4,5x50mm CHT. Screw 4,5x50mm CHT.		Parafuso 3,5x14mm FLA. Tornillo 3,5x14mm FLA. Screw 3,5x14mm FLA.		Cantoneira plástica Cantoneira plástica Plastic angle brackets	

 Estas ferragens constam no Pacote do respectivo Balcão.
Estos herrajes constan en el Paquete del respectivo Balcón.
These hardware are included in the Package of the respective Counter.

AVISO

Para limpeza de seu móvel, use uma flanela seca ou umedecida, e não utilize produtos químicos que possam danificar seu produto.

SISTEMA DE MONTAGEM

O sistema de montagem dos produtos, funciona de acordo com a ordem crescente dos números indicados no desenho. Ex: 01, 02, 03, 04... até a conclusão da montagem.

ADVERTENCIA

Para limpeza de su móvil, use una flanela seca o húmeda, y no utilice productos químicos que puedan dañar su producto.

SISTEMA DE MONTAJE

El sistema de montaje de los productos funciona de acuerdo con el orden creciente de los números indicados en el dibujo. Ej.: 01, 02, 03, 04... hasta la conclusión del montaje.

NOTICE

To clean your furniture, use a dry or wet cloth, and do not use chemicals that may damage your product.

ASSEMBLY SYSTEM

The products' assembly system works according to the increasing order of the indicated numbers. For example: 01, 02, 03, 04 ... to the end of the assembly.

Esse tampo é opcional e é vendido separadamente

Esta vez es opcional y se vende por separado

This top is optional and is sold separately

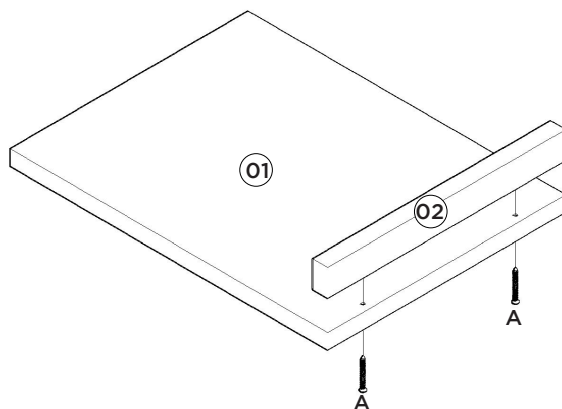

Exemplo de como fixar o Tampo no produto.

Ejemplo de la fijación de la tapa sobre el producto.

Example of fixing the lid on the product.

