



CARRARO
MÓVEIS

Rua Nelson Carraro, 2001 - Bento Gonçalves - Rio Grande do Sul - Brasil - Cep: 95702-798
Fone: (55) 54 3455 12 12 - Fax: (55) 54 3455 12 11 www.carraro.com.br - Cód. Manual: 12000346 - Out 2015

Ref. 592

Ropero 6 Puertas / 6-Door Wardrobe / Roupeiro 6 Portas

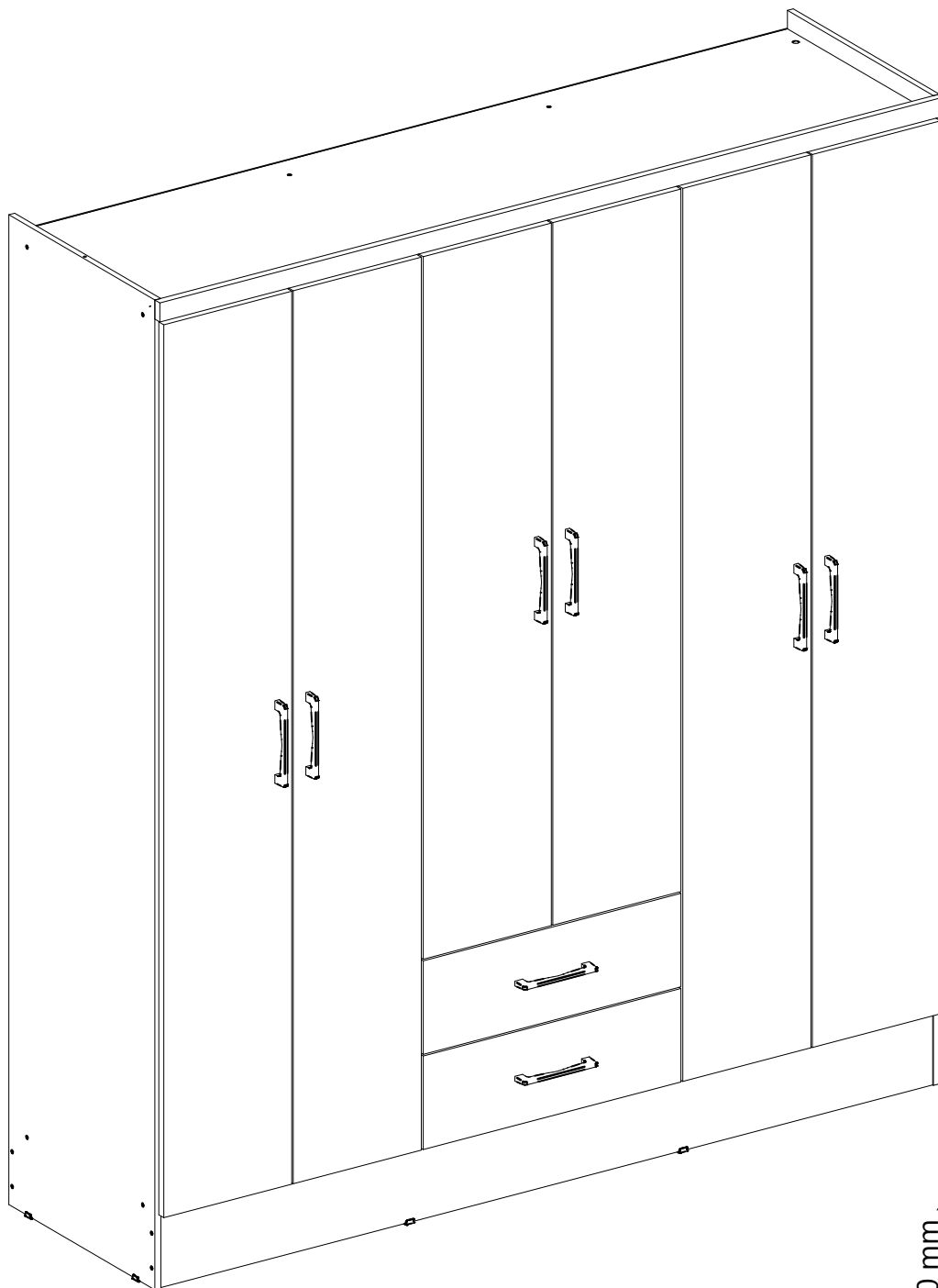

Dimensiones
Dimensions
Dimensões

1820 mm
1600 mm
463 mm

Consejos de Conservación

- No debe utilizarse en la limpieza, abrasivos como lana de acero, alcohol, vinagre, limón, o productos corrosivos que puedan rayar o quitar la película protectora en los muebles.
- Cuando la limpieza de muebles en general, napa y formica, deben utilizarse un paño ligeramente humedecido y jabón suave.
- Para mover el móvil, es importante que este se eleve desde el suelo, debido a que el arrastre puede causar daño estructural.
- No deje a su móvil en exposición a la intemperie.

Conservation Tips

- Do not use abrasive products to clean such as steel wool, alcohol, vinegar, lemon, scouring powder, or corrosive products which can scratch or peel off the protective film of the furniture.
- The best way to clean your furniture is to use a slightly moistened cloth with a mild soap.
- To move the furniture assembled, it is important that it is lifted off the ground, because the drag it can cause structural damage.
- Do not leave your furniture in weather exposure.

Dicas de Conservação

- Não utilizar na limpeza produtos abrasivos tais como: palha de aço, álcool, vinagre, limão, saponáceo, ou produtos corrosivos que possam riscar ou descolar a película protetora dos móveis.
- Na limpeza de móveis em geral, napa e fórmicas, deve ser utilizado um pano levemente umedecido e sabão neutro.
- Para a movimentação do móvel, é importante que este seja levantado do chão, pois ao arrastá-lo pode causar avarias estruturais.
- Não deixe o móvel em exposição a intempéries.

Certificado de Garantia

A garantia dos produtos fabricados pela Carraro, abrange eventuais defeitos/vícios de fabricação, no prazo estabelecido pelo Código de Defesa do Consumidor, em seu artigo 26,II, o qual prevê a garantia legal de 90 (noventa) dias.

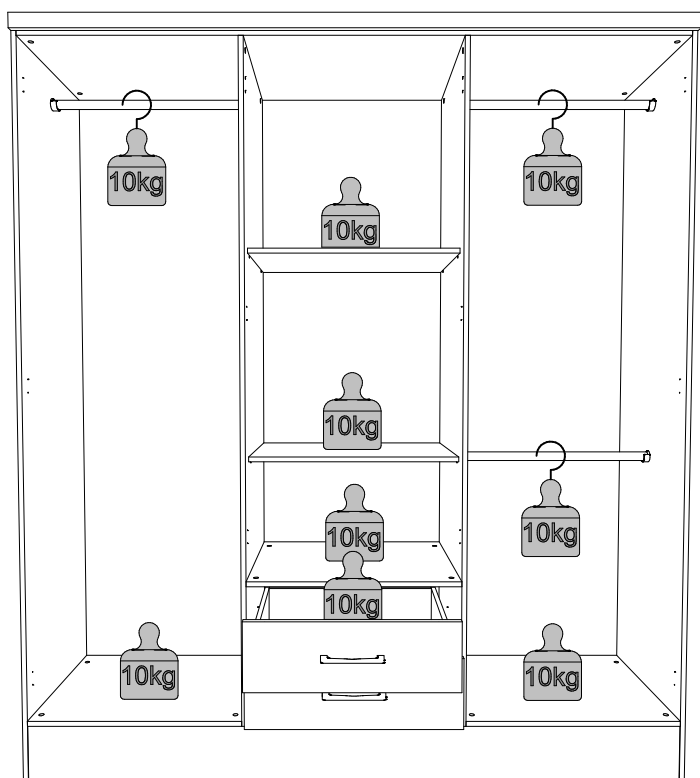

Peso por estante

Por favor, preste atención a los pesos máximos admitidos por cada compartimento del producto. Tenga cuidado de no exceder estos pesos, con el fin de garantizar la calidad y durabilidad del producto.

Es importante recordar que los pesos muestran en caso de ser distribuida en toda el área de la plataforma.

Weight per shelf

Please pay attention to the maximum weights supported by each compartment product. Be careful not to exceed these weights, in order to ensure the quality and durability of the product. It is important to remember also that the weights shown should be distributed throughout the area of the shelf.

Peso por Prateleira

Ao lado são demonstrados os pesos máximos suportados por cada compartimento do produto. Cuide para não exceder esses pesos, afim de garantir a qualidade e a durabilidade do mesmo. É importante lembrar também, que os pesos mostrados devem ser DISTRIBUÍDOS ao longo de toda a área da peça.

LISTA DE PIEZAS / LIST OF PARTS / RELAÇÃO DE PEÇAS

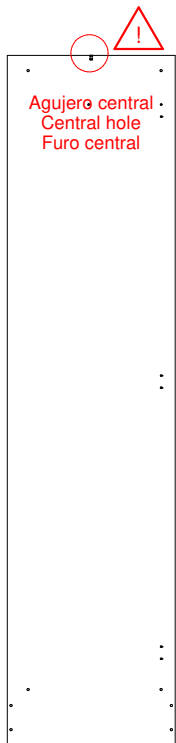

Agujero central
Central hole
Furo central

1 Lateral izquierda
Left side
Lateral esquerda
1820 x 444 x 12

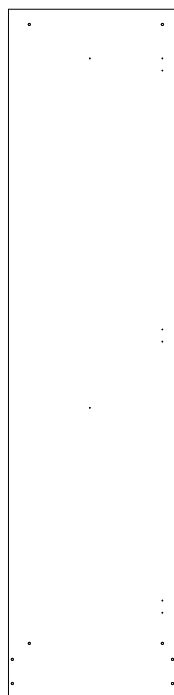

2 Lateral derecha
Right side
Lateral direita
1820 x 444 x 12



3 División derecha
Right division
Divisão direita
1637 x 444 x 12

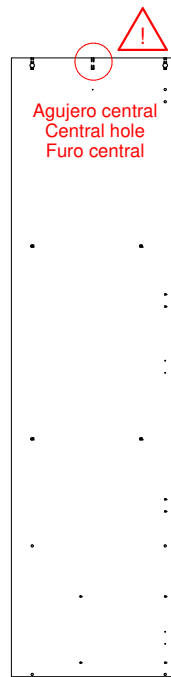

Agujero central
Central hole
Furo central

4 División izquierda
Left division
Divisão esquerda
1637 x 444 x 12



5 Marco
Frame
Moldura
1600 x 35 x 15

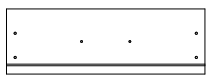

6 Frente del cajón
Drawer front
Frente de gaveta
525 x 172 x 15 | 2 un.



7 Costado del Cajón
Drawer back Panel
Costa de gaveta
467 x 100 x 12 | 2 un.



8 Lateral del cajón
Drawer side
Lateral de gaveta
385 x 100 x 12 | 4 un.

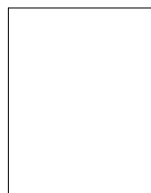

9 Fondo del cajón
Drawer Bottom
Fundo de Gaveta
492 x 387 x 2,5 | 2 un.



10 Repisa
Shelf
Prateleira
517 x 380 x 12 | 2 un.

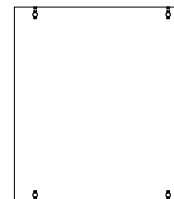

11 Base
Base
Base
517 x 444 x 12 | 3 un.



12 Tapa
Top
Chapéu
1575 x 444 x 12



13 Costado
Back panel
Costa
1647 x 530 x 2.5 | 3 un.

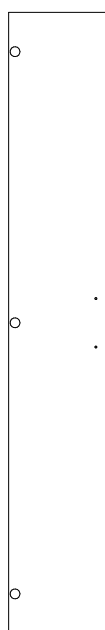

14 Puerta Maior
Biggest Door
Porta Maior
1642 x 261 x 15 | 2 un.



15 Puerta Menor
Smaller Door
Porta Menor
1292 x 261 x 15 | 2 un.

Zócalo Delantero: Revestido
Frontal Baseboard: With finish
Rodapé Frontal: Com acabamento

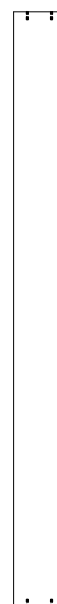

16 Zócalo
Baseboard
Rodapé
1575 x 137 x 15/12 | 2 un.

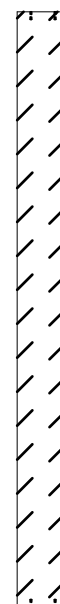

Zócalo Trasero: Sin revestimiento
Back Baseboard: Unfinished
Rodapé Traseiro: Sem acabamento

ACCESORIOS / HARDWARE / ACESSÓRIOS

A

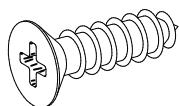

Ø4 x 12 | 110 un.

B

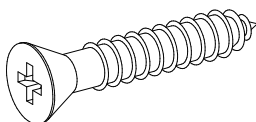

Ø4 x 25 | 16 un.

C

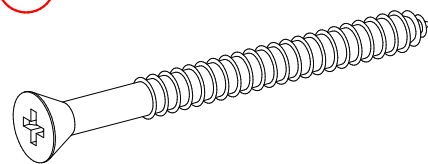

Ø4,5 x 50 | 28 un.

D

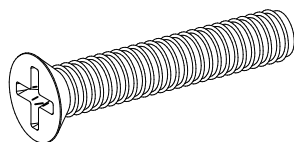

M4 x 22 | 4 un.

E

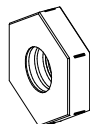

M4 | 4 un.

F

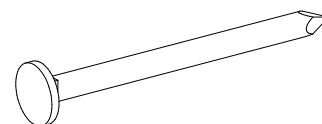

102 un.

G

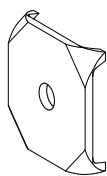

24 un.

H



20 un.

I

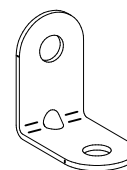

12 un.

J

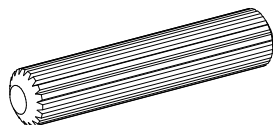

8 un.

K



1 un.

L

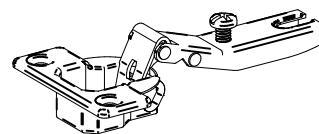

18 un.

M



18 un.

N



8 un.

O

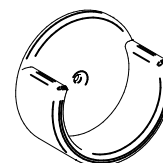

6 un.

P

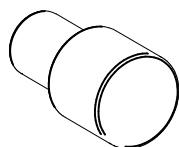

8 un.

Q



8 un.

R



1 un.

S

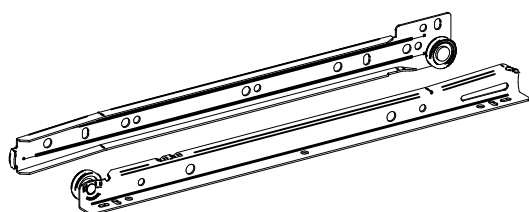

2 un.

T

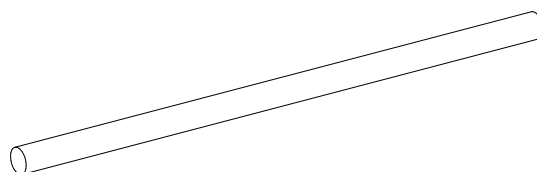

3 un.

FERRAMENTAS
HARDWARE
FERRAMENTAS

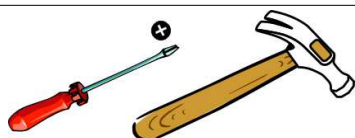

PERSONAS NECESARIAS PARA EL MONTAJE
PEOPLE REQUIRED FOR ASSEMBLY
PESSOAS NECESSÁRIAS PARA A MONTAGEM



Pre Montaje

Pre Assembly

Pré Montagem

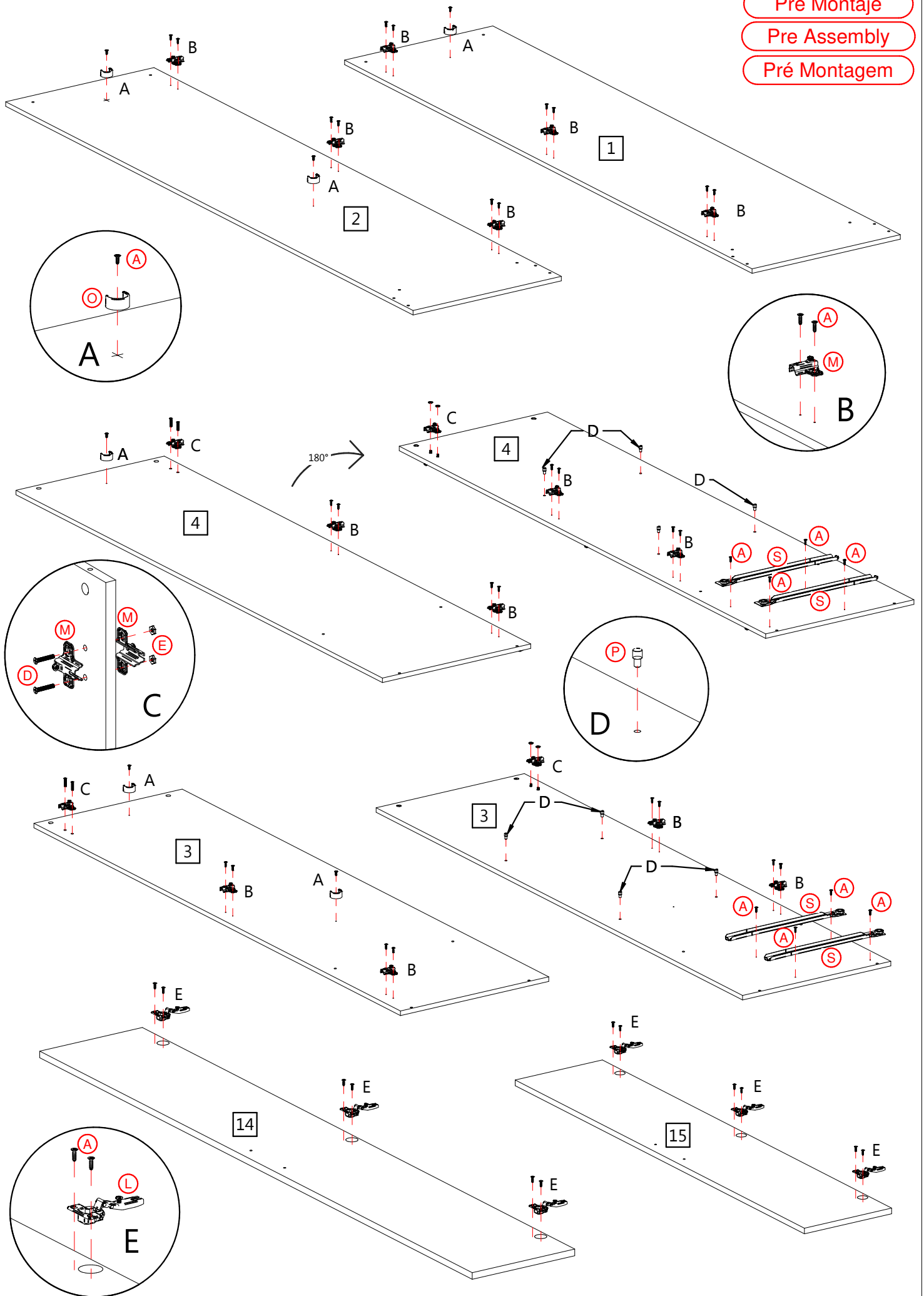

1

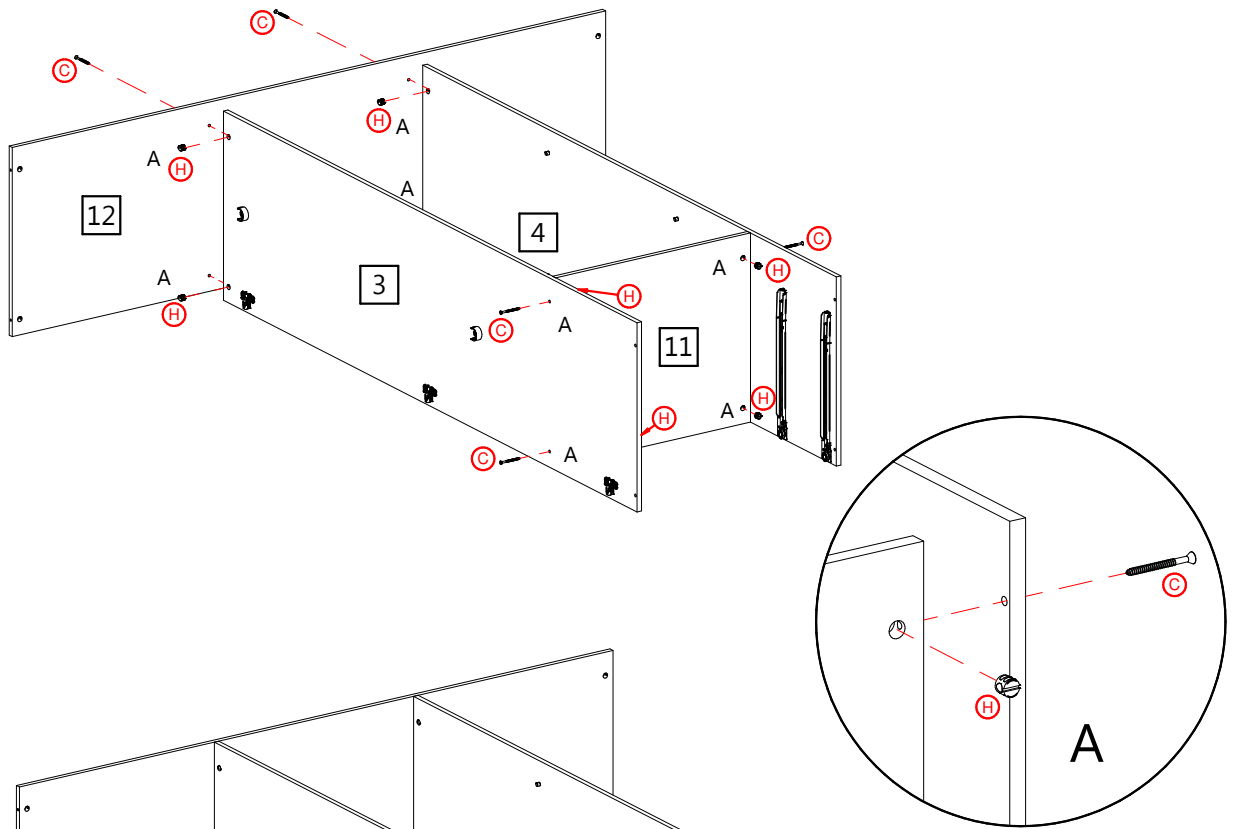

2

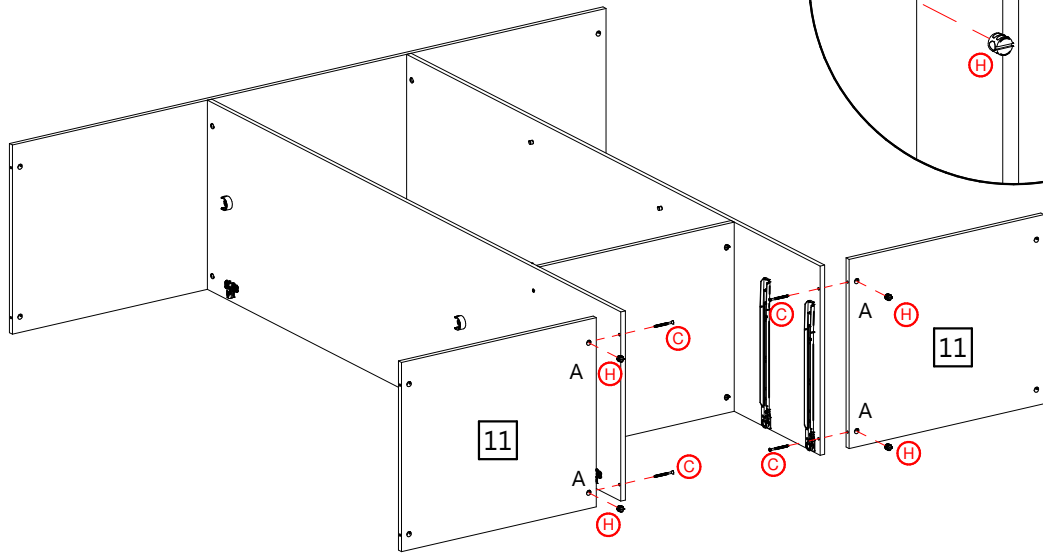

3

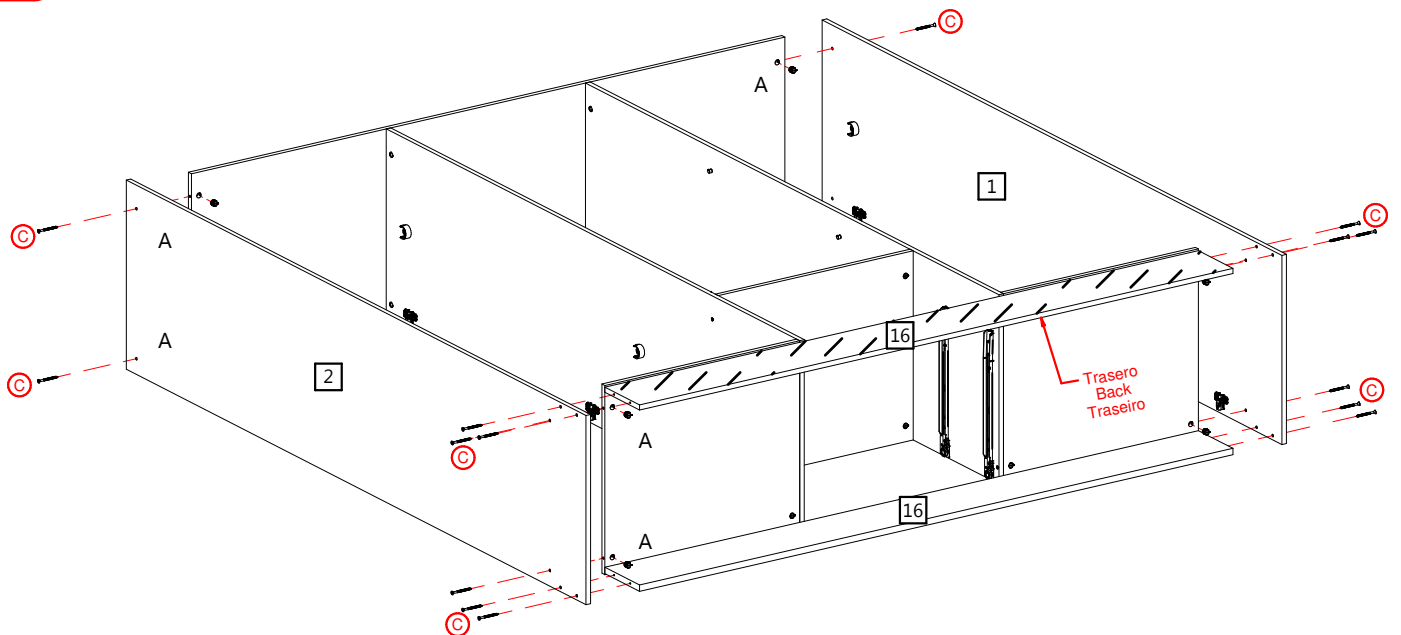

4

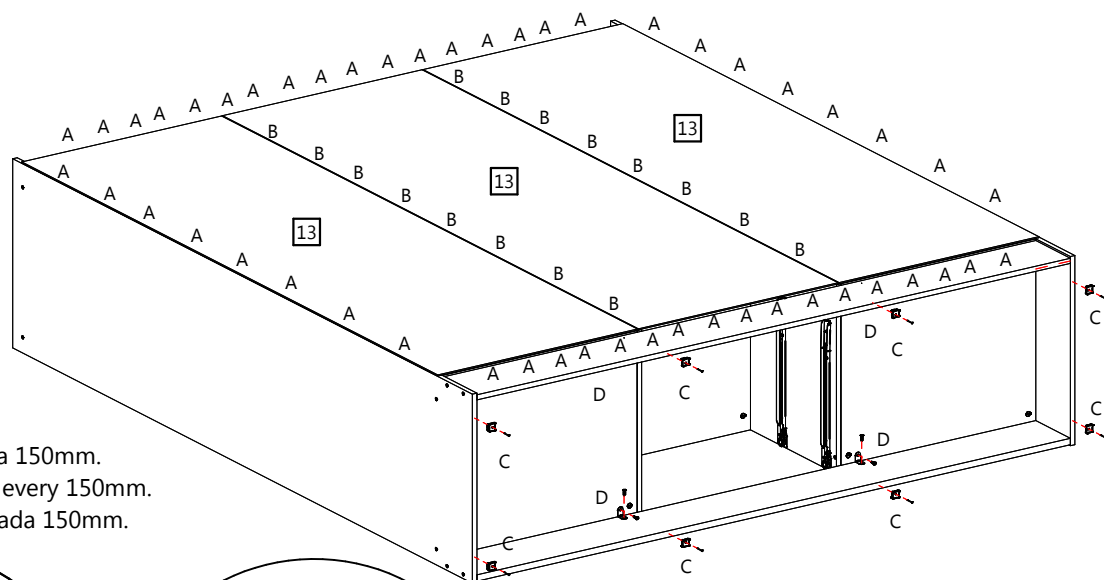

Fijar costado con clavos cada 150mm.
Fasten back panel with nails every 150mm.
Fixar costas com pregos, a cada 150mm.

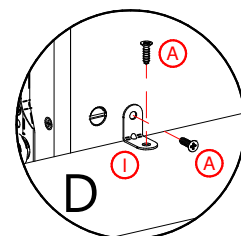
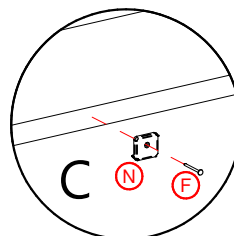
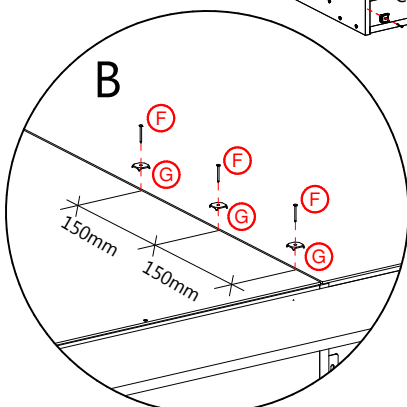
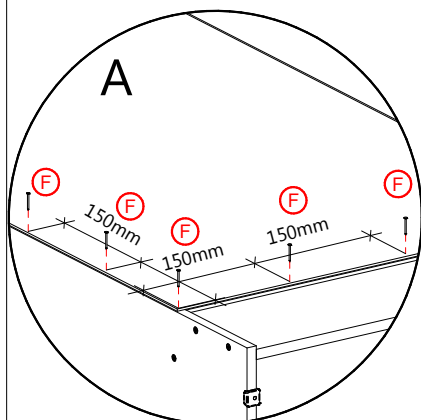

5 x 2

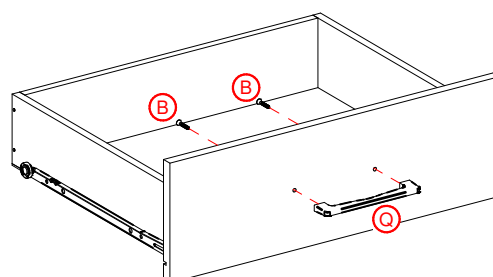
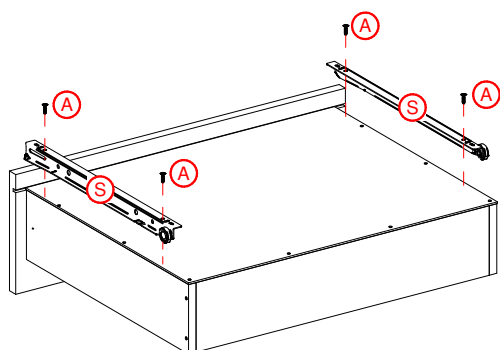
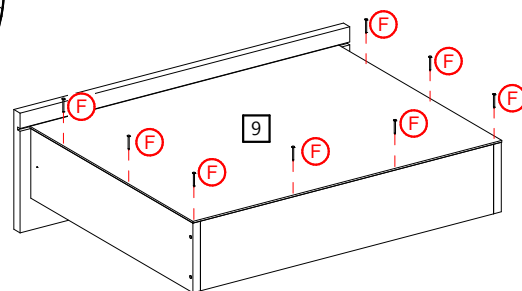
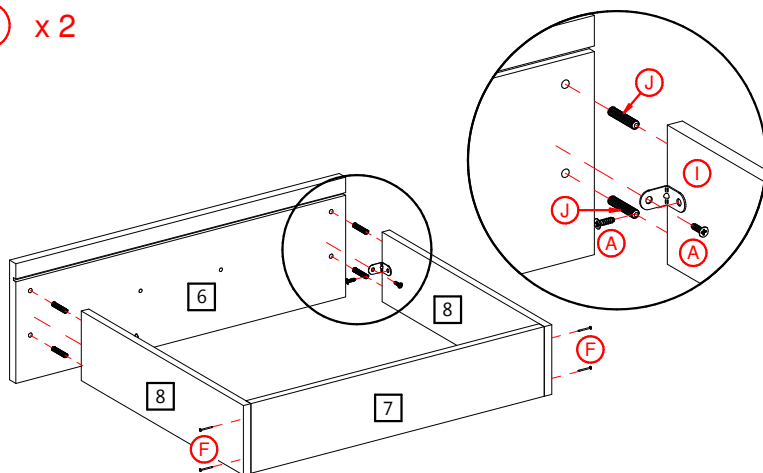

6

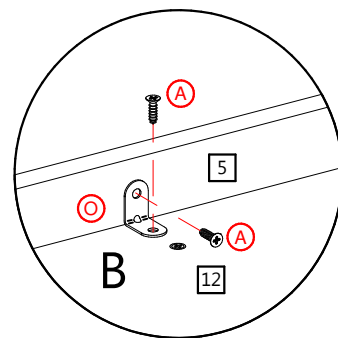
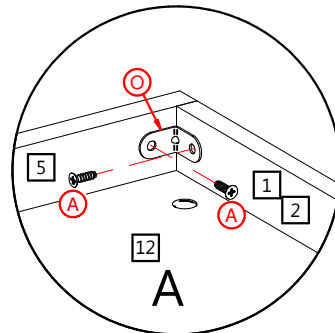
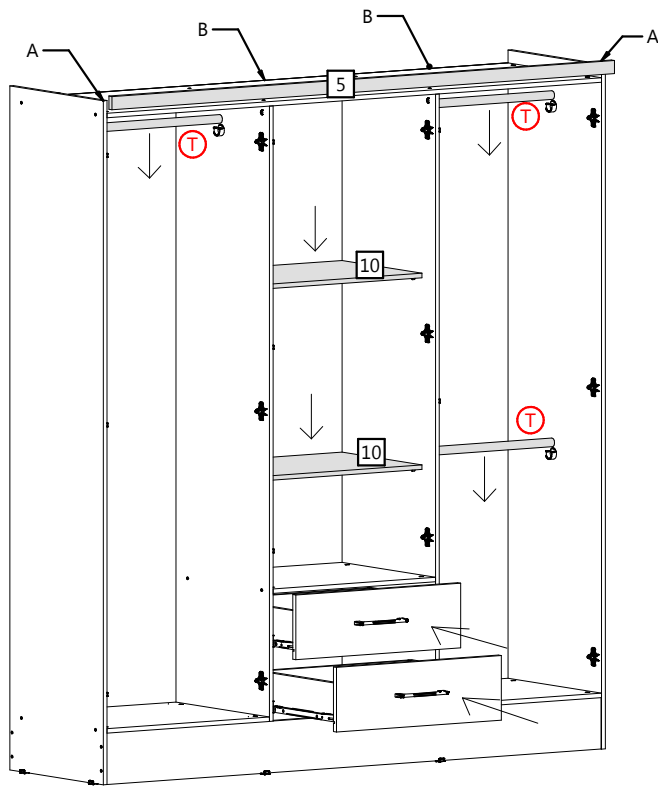

7

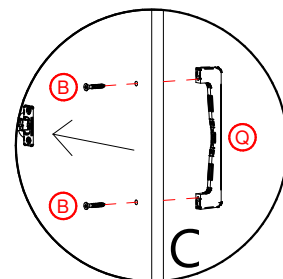
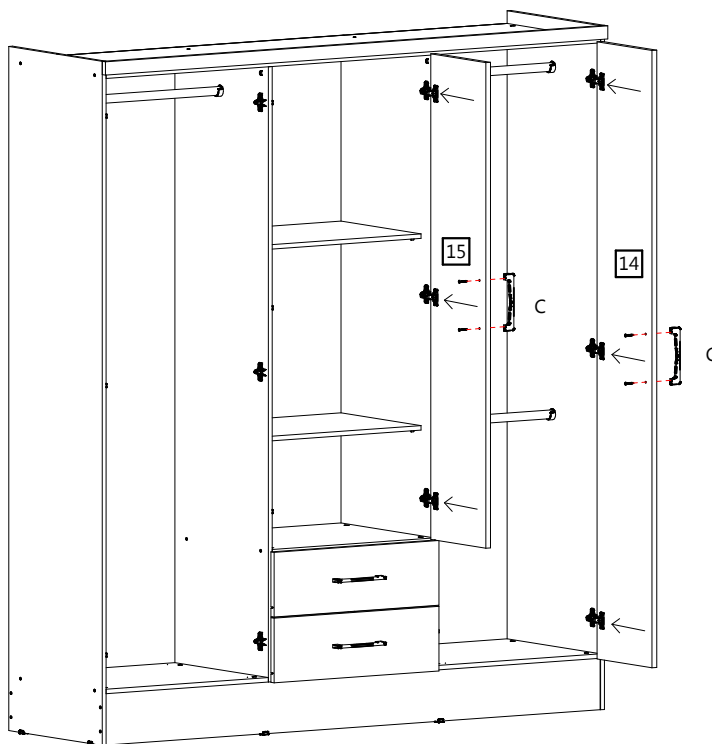

Ajuste das Portas / Door Adjustment / Ajuste de las Puertas

Encaixe da porta
Door setting
Encaje de la puerta

Ajuste de Altura
Height Adjustment
Ajuste del alto

Ajuste Interno
Internal Adjustment
Ajuste Interno

Ajuste de Profundidade
Depth Adjustment
Ajuste de la profundidad

