

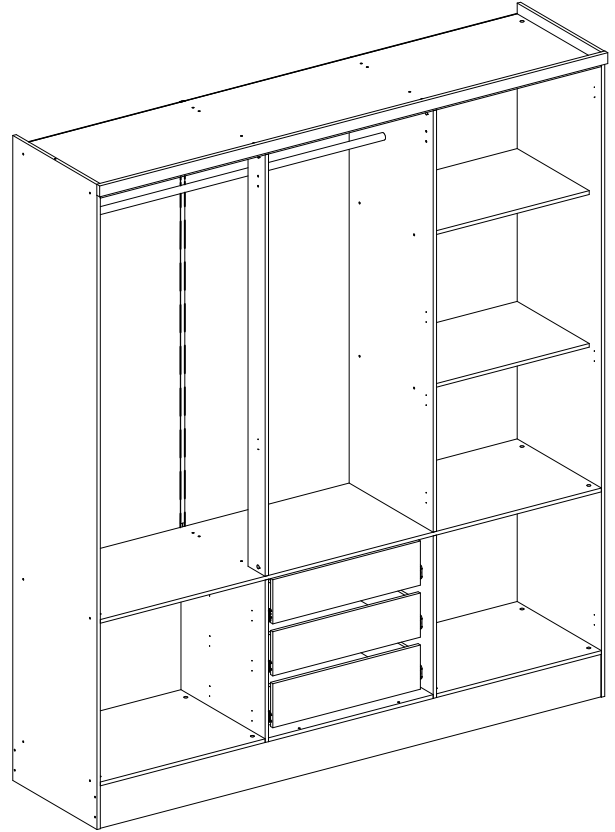

CARRARO
MÓVEIS

Ref. 578

INSTRUCCIONES DE MONTAJE / ASSEMBLY INSTRUCTION / ESQUEMA DE MONTAGEM
Ropero 6 Puertas 3 Cajón / Wardrobe 6 Doors 3 Drawer / Roupeiro 6 Portas 3 Gavetas

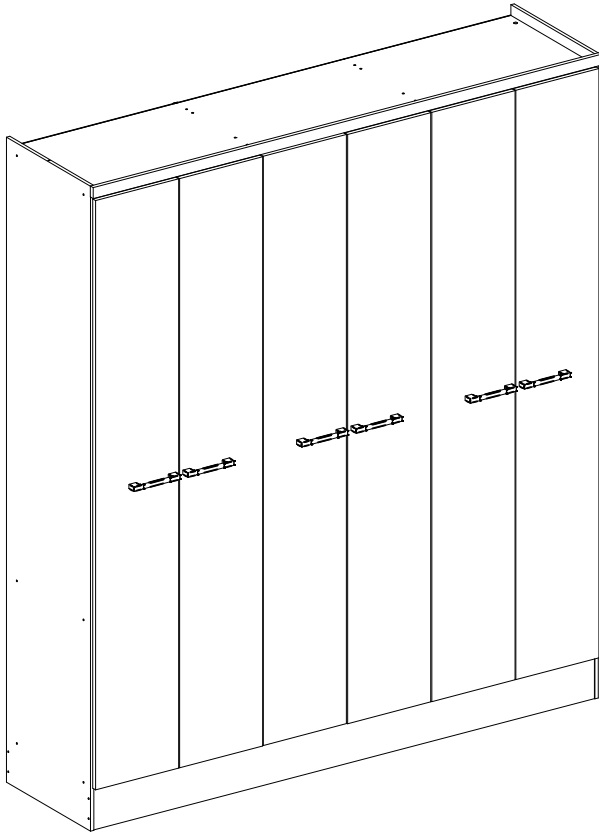

ACESSORIOS / HARDWARE / ACESSÓRIOS

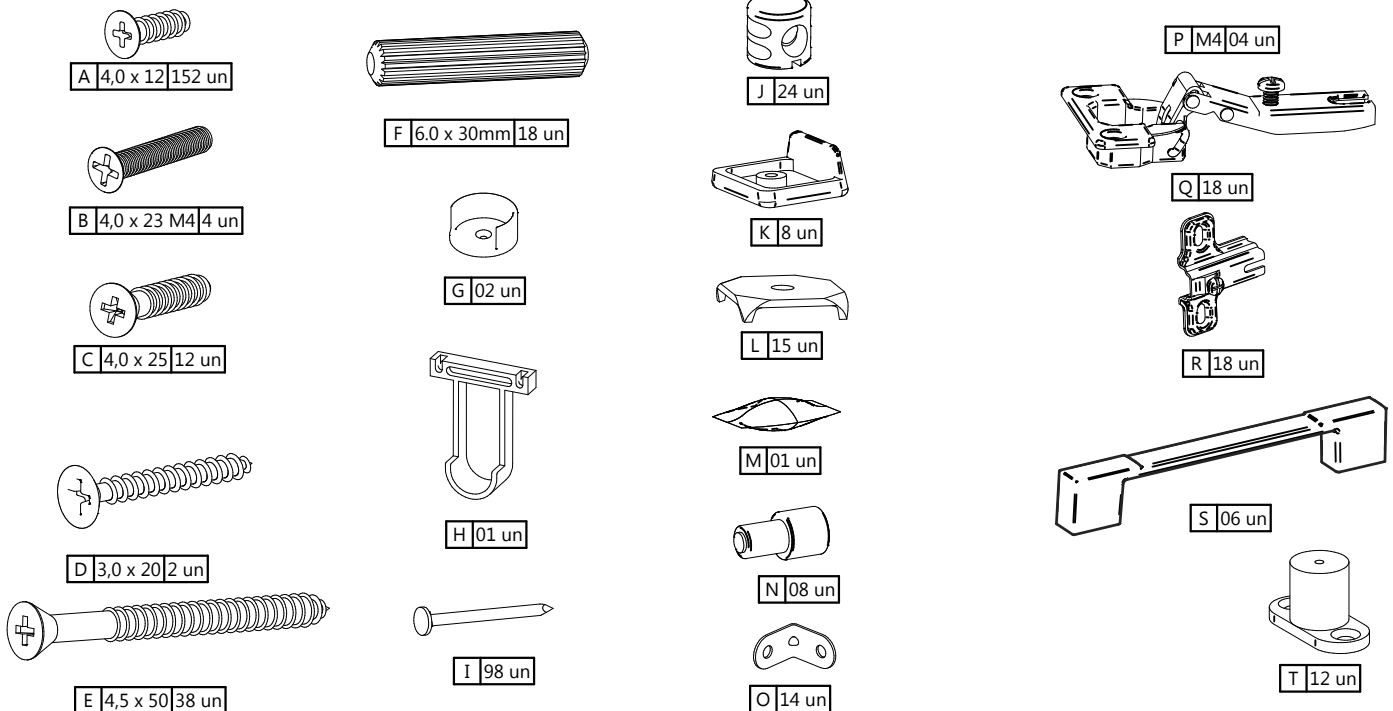

FERRAMIENTAS
HARDWARE
FERRAMENTAS

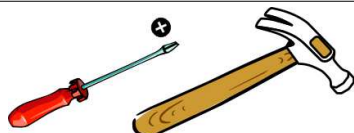

PERSONAS NECESARIAS PARA EL MONTAJE
PEOPLE REQUIRED FOR ASSEMBLY
PESSOAS NECESSÁRIAS PARA A MONTAGEM



Consejos de Conservación

- No debe utilizarse en la limpieza, abrasivos como lana de acero, alcohol, vinagre, limón, o productos corrosivos que puedan rayar o quitar la película protectora en los muebles.
- Cuando la limpieza de muebles en general, napa y formica, deben utilizarse un paño ligeramente humedecido y jabón suave.
- Para mover el móvil, es importante que este se eleve desde el suelo, debido a que el arrastre puede causar daño estructural.
- No deje a su móvil en exposición a la intemperie.

Conservation Tips

- Do not use abrasive products to clean such as steel wool, alcohol, vinegar, lemon, scouring powder, or corrosive products which can scratch or peel off the protective film of the furniture.
- The best way to clean your furniture is to use a slightly moistened cloth with a mild soap.
- To move the furniture assembled, it is important that it is lifted off the ground, because the drag it can cause structural damage.
- Do not leave your furniture in weather exposure.

Dicas de Conservação

- Não utilizar na limpeza produtos abrasivos tais como: palha de aço, álcool, vinagre, limão, saponáceo, ou produtos corrosivos que possam riscar ou descolar a película protetora dos móveis.
- Na limpeza de móveis em geral, napa e fórmicas, deve ser utilizado um pano levemente umedecido e sabão neutro.
- Para a movimentação do móvel, é importante que este seja levantado do chão, pois ao arrastá-lo pode causar avarias estruturais.
- Não deixe o móvel em exposição a intempéries.

Certificado de Garantia

A garantia dos produtos fabricados pela Carraro, abrange eventuais defeitos/vícios de fabricação, no prazo estabelecido pelo Código de Defesa do Consumidor, em seu artigo 26,II, o qual prevê a garantia legal de 90 (noventa) dias.

Peso por estante

Por favor, preste atención a los pesos máximos admitidos por cada compartimento del producto. Tenga cuidado de no exceder estos pesos, con el fin de garantizar la calidad y durabilidad del producto.

Es importante recordar que los pesos muestran en caso de ser distribuida en toda el área de la plataforma.

Weight per shelf

Please pay attention to the maximum weights supported by each compartment product. Be careful not to exceed these weights, in order to ensure the quality and durability of the product. It is important to remember also that the weights shown should be distributed throughout the area of the shelf.

Peso por Prateleira

Ao lado são demonstrados os pesos máximos suportados por cada compartimento do produto. Cuide para não exceder esses pesos, afim de garantir a qualidade e a durabilidade do mesmo. É importante lembrar também, que os pesos mostrados devem ser DISTRIBUÍDOS ao longo de toda a área da peça.

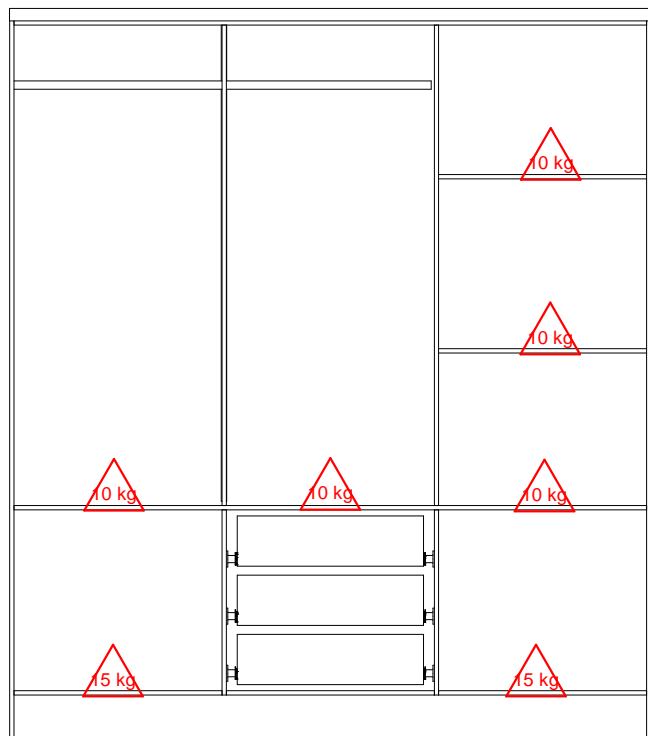

LISTA DE PIEZAS / LIST OF PARTS / RELAÇÃO DE PEÇAS

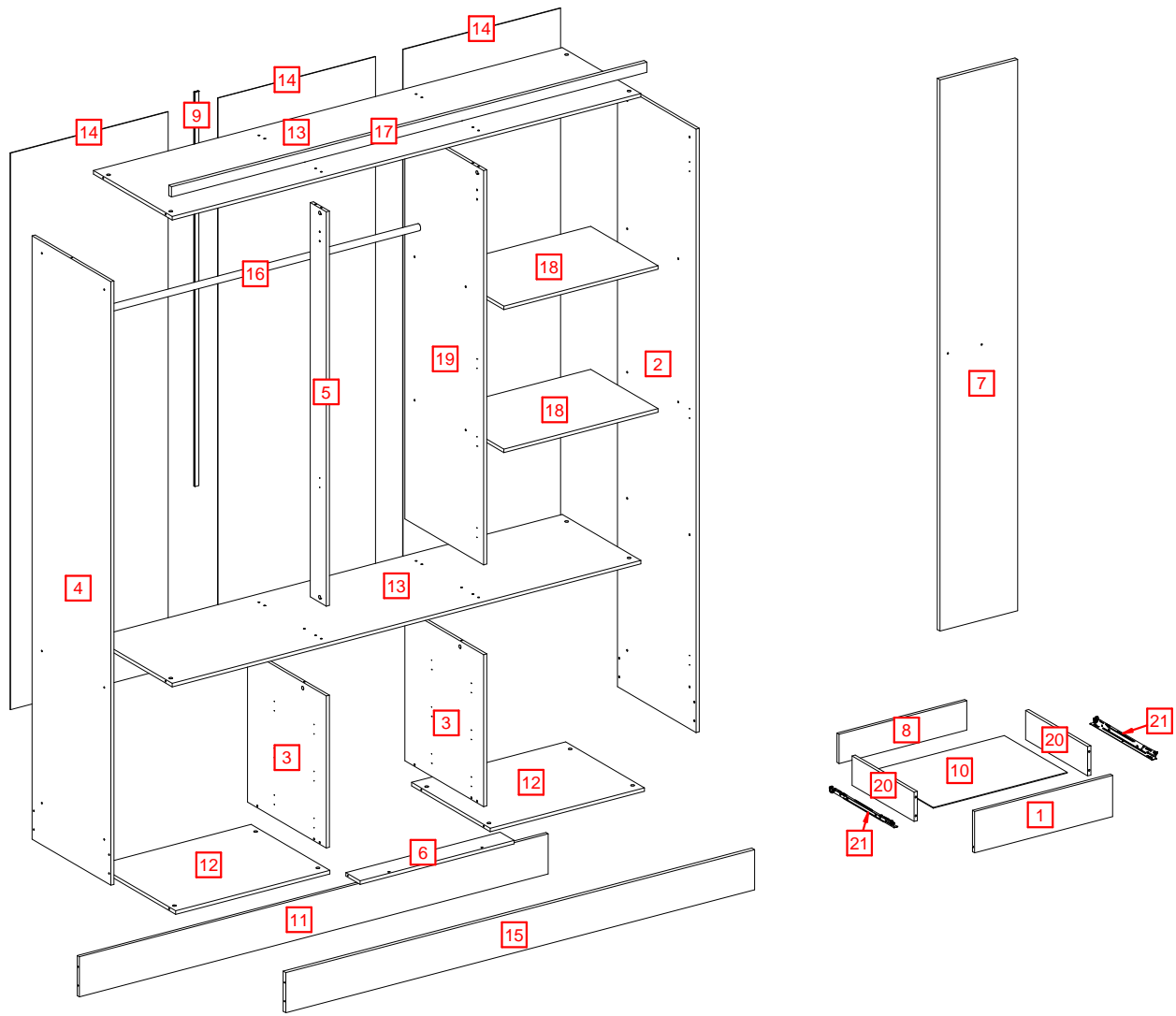

#	Quantity Cantidad Quant.	Pieza	Piece	Peça	Dimensiones (mm) Dimensions (mm) Dimensões (mm)	Códigos para repuestos / Codes for replacement / Códigos para reposição					
						Roble / Oak Carvalho	Gamuza / Chamois Camurça	Gris / Grey Gris	Tabaco / Tobacco Tabaco	Blanco / White Branco	Negro / Black Preto
1	3	Frente de Cajón	Front Drawer	Frente de Gaveta Interna	522 x 135 x 12		057815992				
2	1	Lateral Derecha	Right Side	Lateral Direita	2060 x 444 x 12	057815922		057815929	057815916	057815909	
3	2	División Derecha /Izquierda	Left/Right Division	Divisão Direita/Esquerda	519 x 444 x 12	057815976		057815986	057815981	057815969	
4	1	Lateral Izquierda	Left Side	Lateral Esquerda	2060 x 444 x 12	057815923		057815931	057815917	057815911	
5	1	Pilastra Derecha/Izquierda	Left/Right Pilaster	Pilastra Direita/Esquerda	1346 x 90 x 12	057815978		057815989	057815984	057815972	
6	1	Travessa Base	Base Crosspiece	Travessa Base	583 x 80 x 12	057815979		057815991	057815985	057815973	
7	6	Puerta	Door	Porta Maior	1882 x 294 x 15	057815921		057815954	057815928	057815915	057815925
8	3	Costa de Cajón	Drawer Back	Costa de Gaveta Interna	483 x 100 x 12		057814116				
9	1	Perfil "I"	Profile "I"	Perfil I	1346 x 15 x 6		000037522				
10	3	Fondo de Cajón	Drawer Bottom	Fundo de Gaveta Interna	507 x 355 x 2,5		057814149				
11	1	Zócalo Trasero	Back Baseboard	Rodapé Traseiro	1773 x 137 x 12		057804109				
12	2	Base	Base	Base	583 x 444 x 12	057815924		057815932	057815918	057815913	
13	2	Tapa	Upper Base	Chapéu-Tampo Cômoda	1773 x 444 x 12	057815975		057815987	057815982	057815974	
14	3	Costado	Back	Costa	1900 x 596 x 2,5		057815732				
15	1	Zócalo Frontal	Frontal Baseboard	Rodapé Dianteiro	1773 x 137 x 15	057814216		057814887	057810164	057810221	
16	1	Rolizo Percha	Hanger Rod	Cabideiro	∅23 x 1169						000017248
17	1	Marco	Frame	Moldura	1798 x 35 x 15	057814275		057814878	057809856	057813242	
18	2	Repisa Móvil	Mobile Shelf	Prateleira Móvel	583 x 380 x 12		057815914				
19	1	División Superior Derecha	Upper Division	Divisão Superior Direita	1346 x 444 x 12	057817977		057815988	057815983	057815971	057815971
20	6	Lateral de Cajón	Drawer Side	Lateral de Gaveta	350 x 100 x 12		057814152				
21	3	Corredera Metalica	Metalic Slide	Corrediça Metálica	Compr.: 350mm						000018095
22	1	Accesorios	Accessories	Acessórios	-						000046217

01

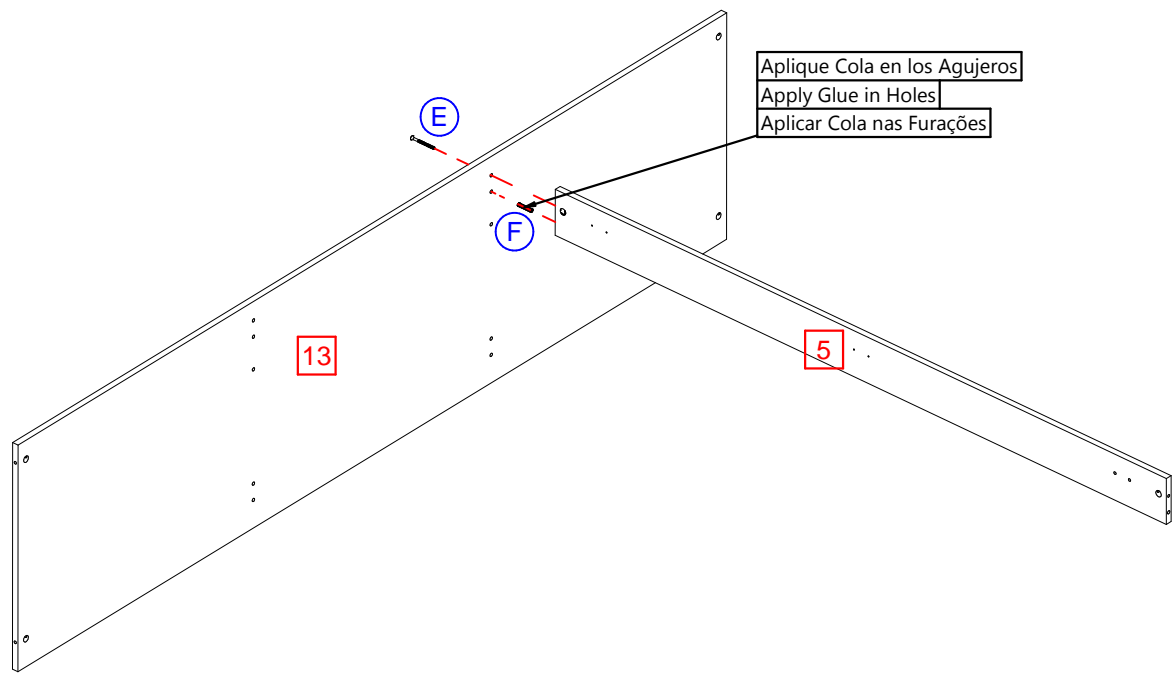

02

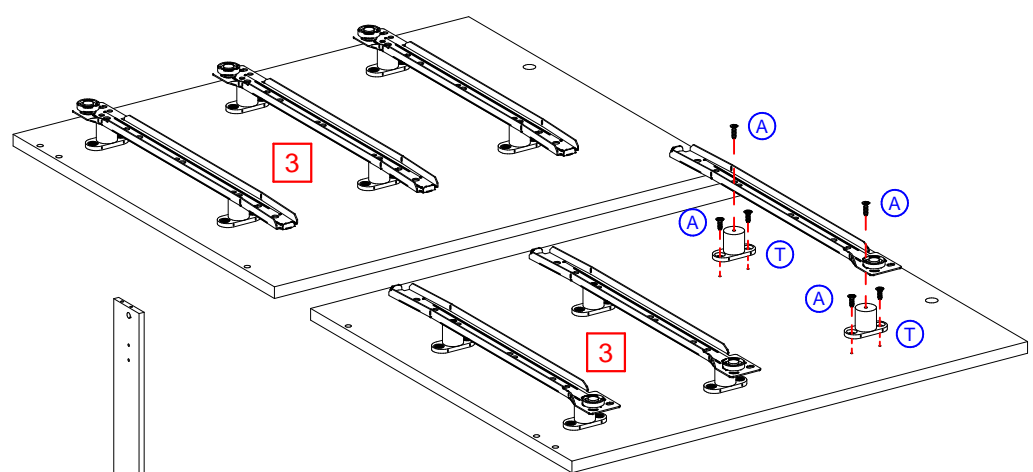

03

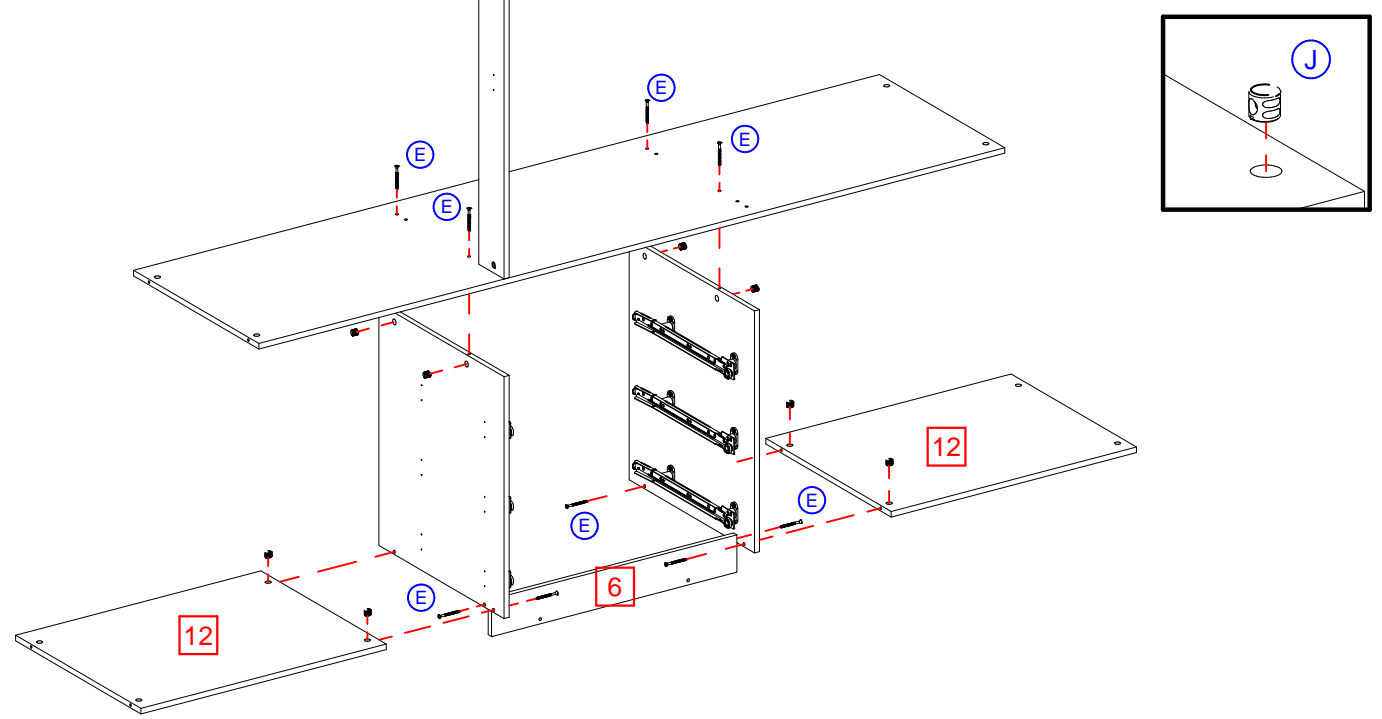

04

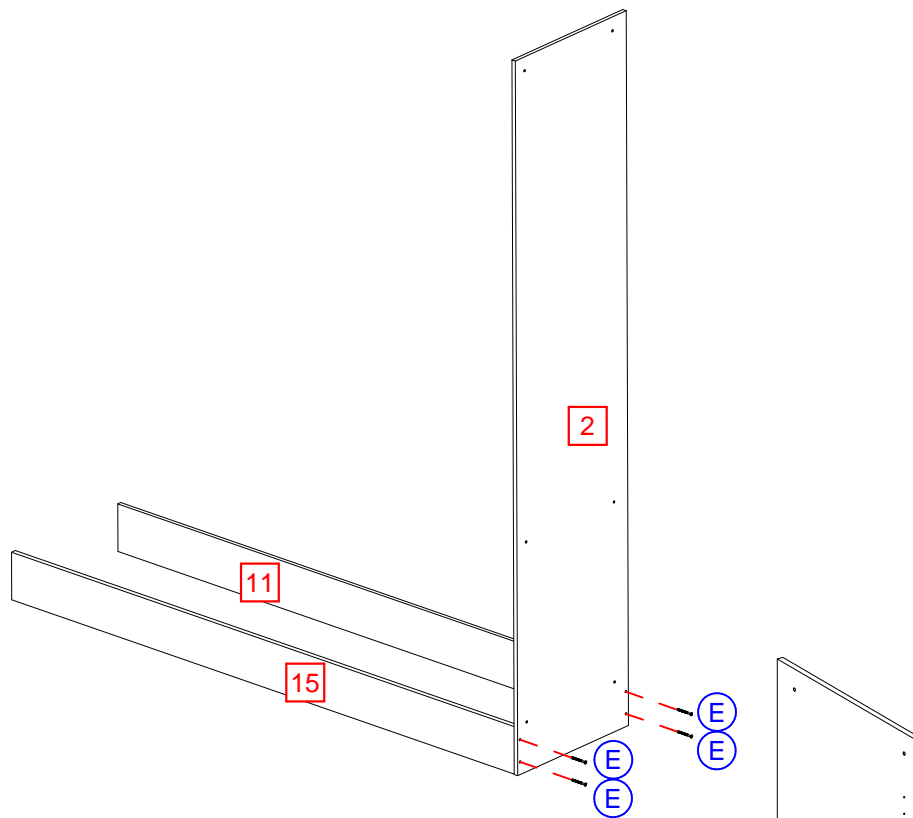

05

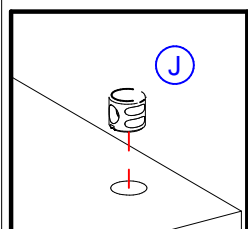
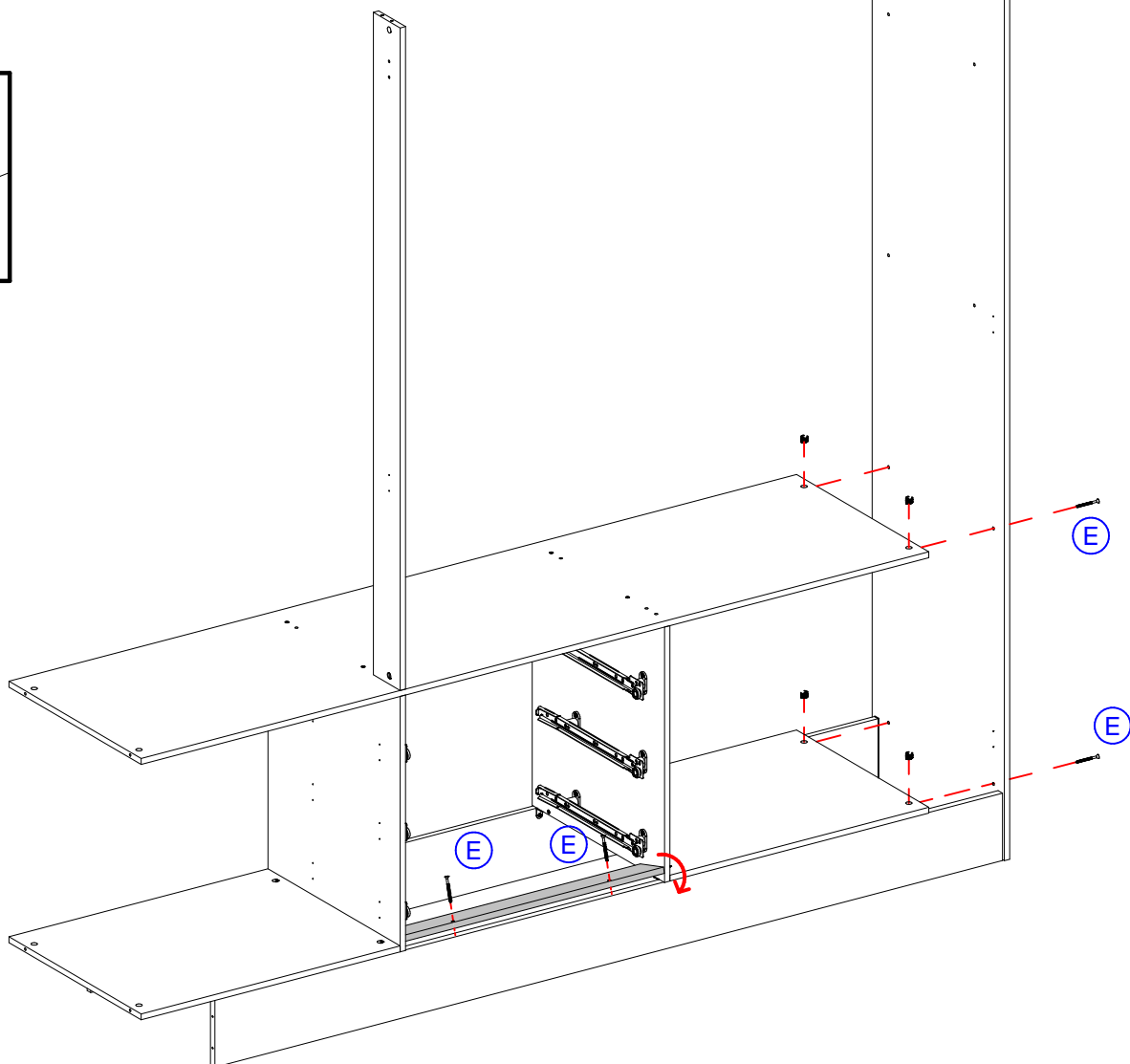
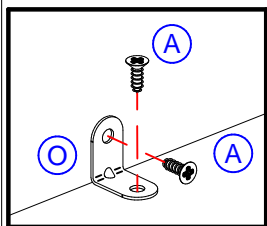

06

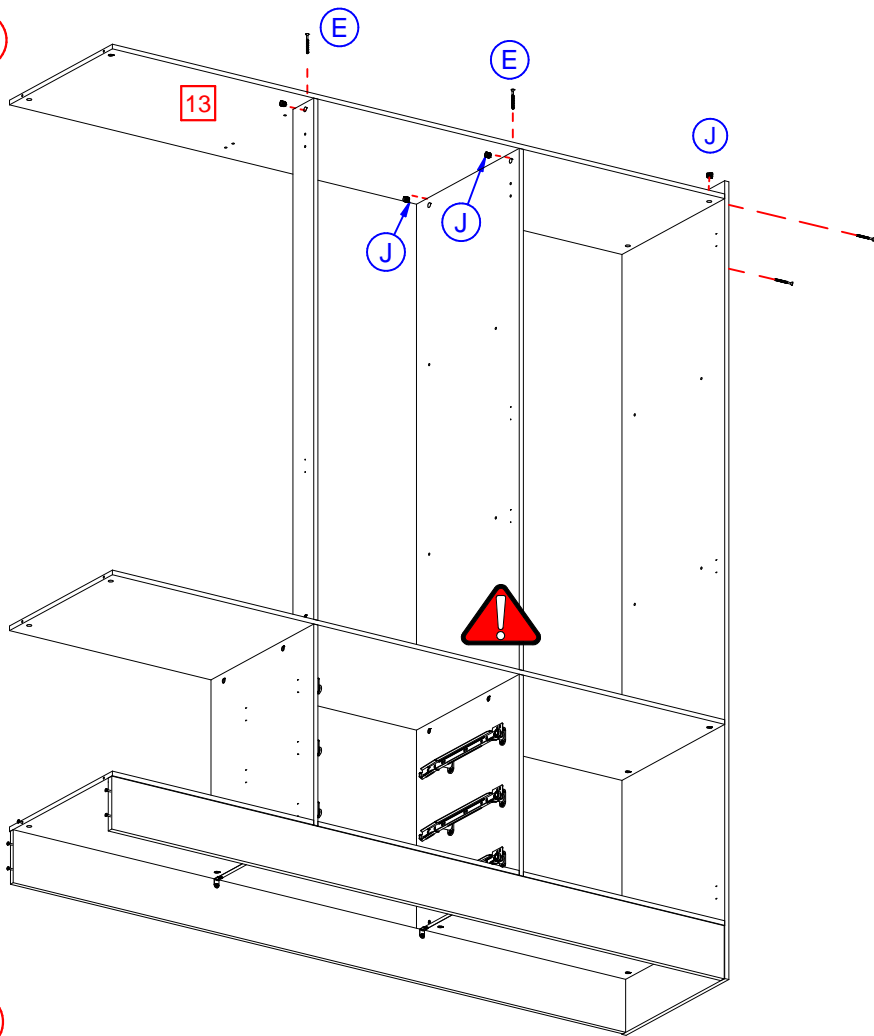

Simultáneamente, el montaje de los accesorios de este paso, colocar los pernos.
At the same time the mounting of accessories in this step, placing the bolts.
Simultaneamente a montagem destes acessórios neste passo, colocar as cavilhas.

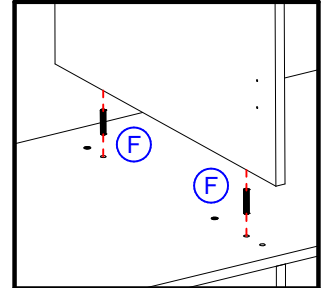

07

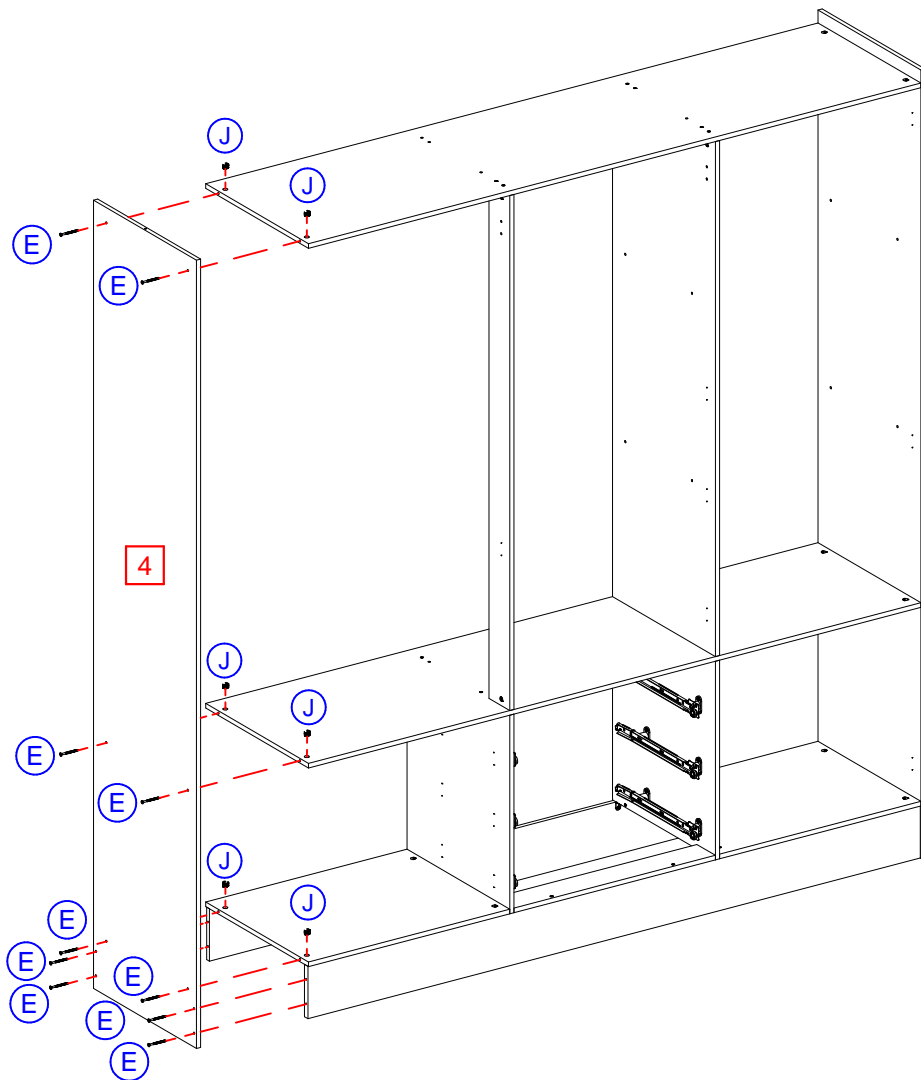

08

Colocación de clavos en área poblada
Distancia entre clavos: 200 mm

Placing nails in populated area
Distance between nails: 200mm

Colocar pregos na area preenchida
Distância entre pregos: 200mm

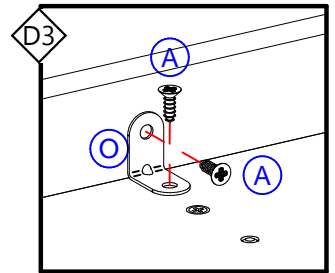
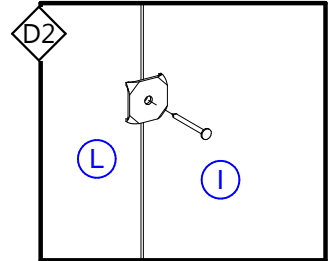
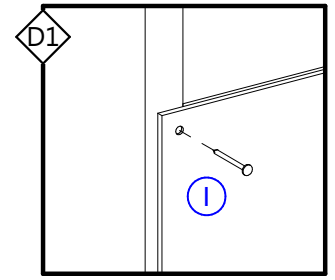
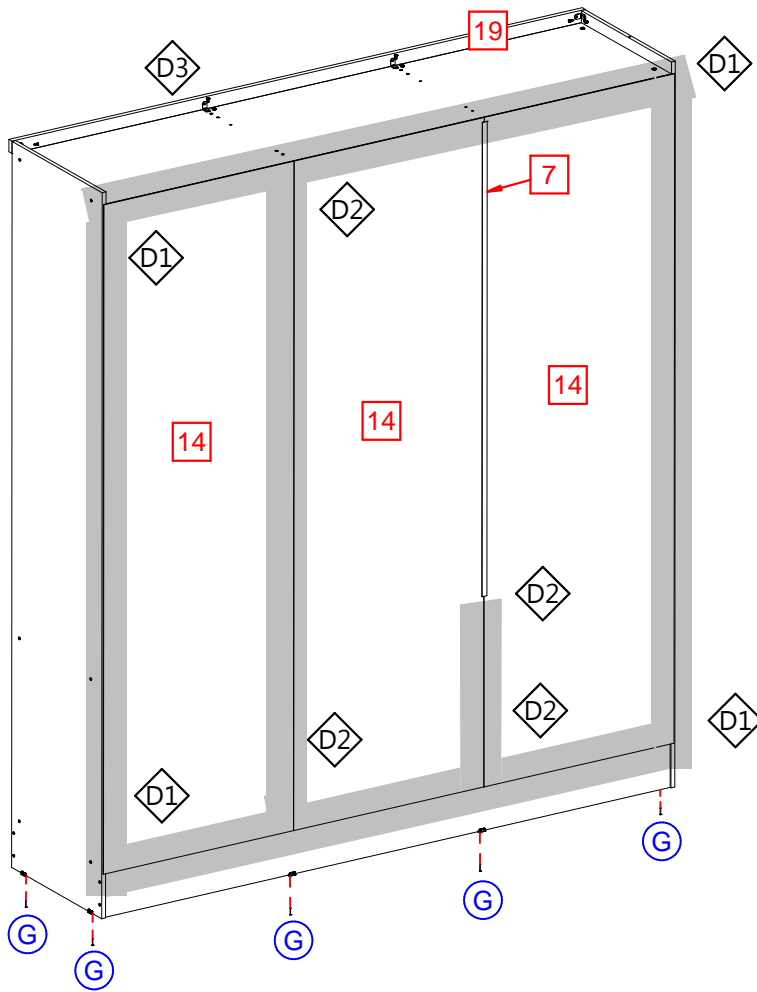

Centralizar accesorio con Pilastra
 Centralize accessory with Pilaster
 Centralizar o acessório com a Pilastra

09

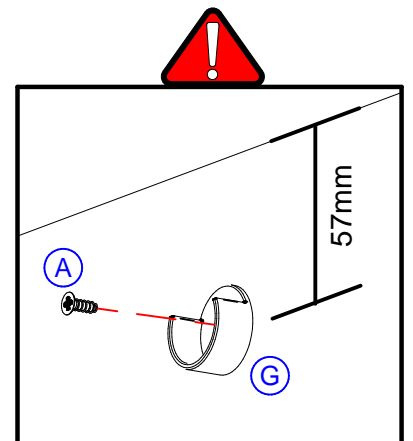
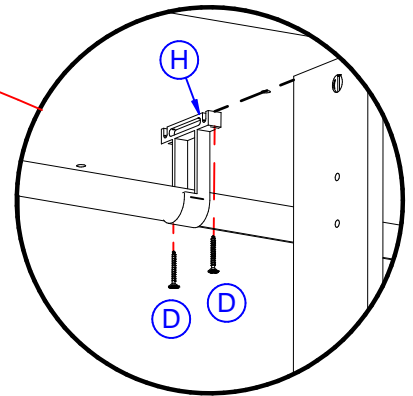
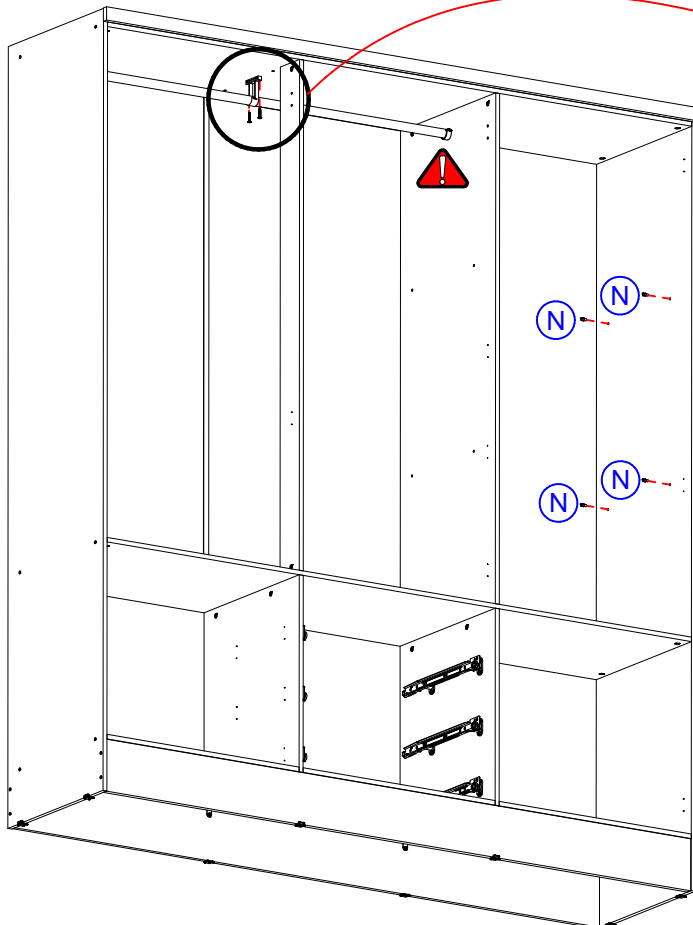

10

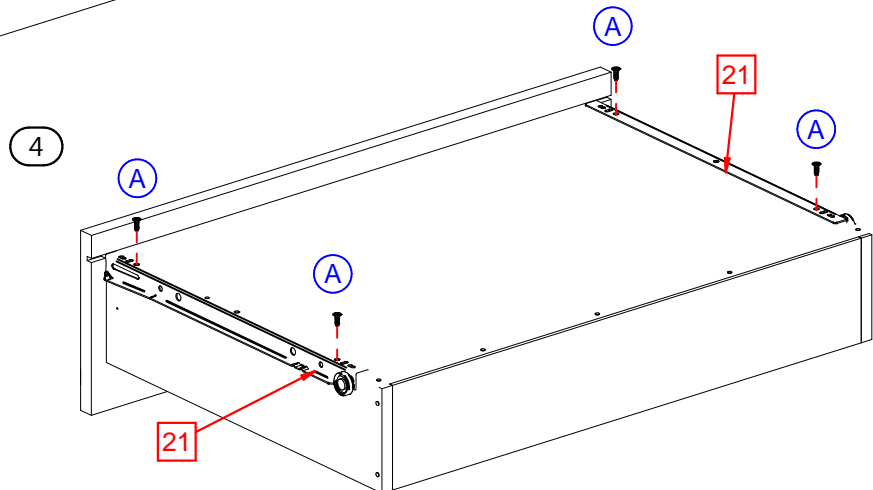
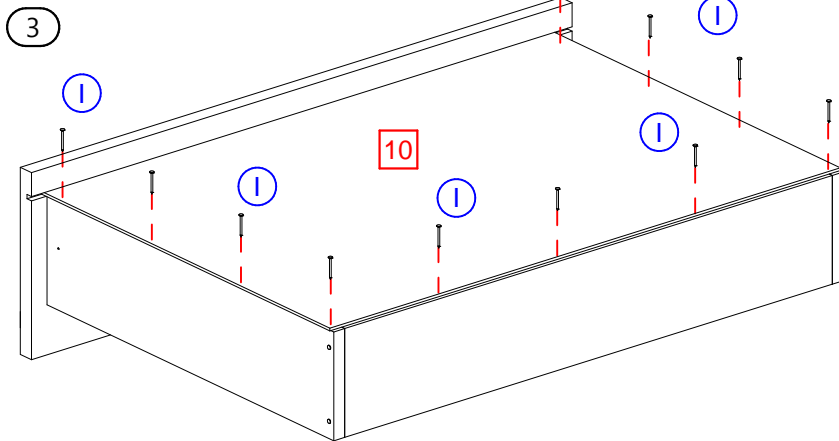
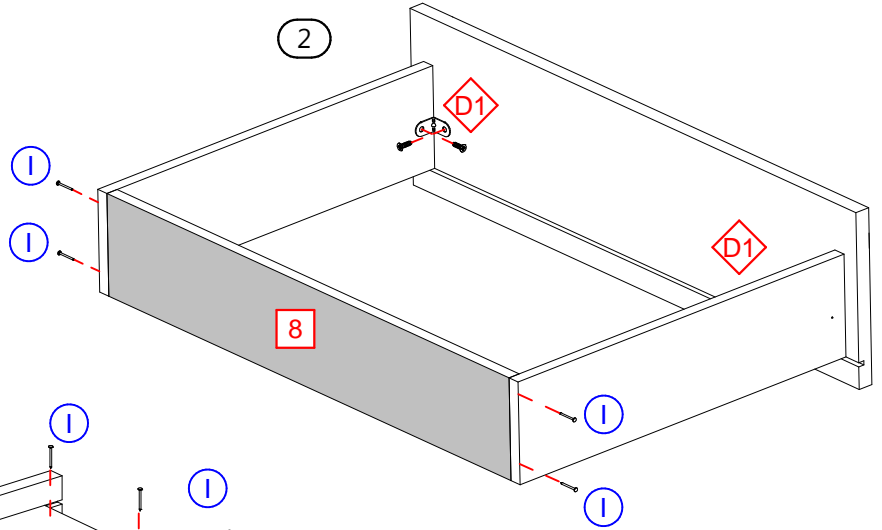
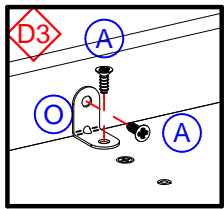
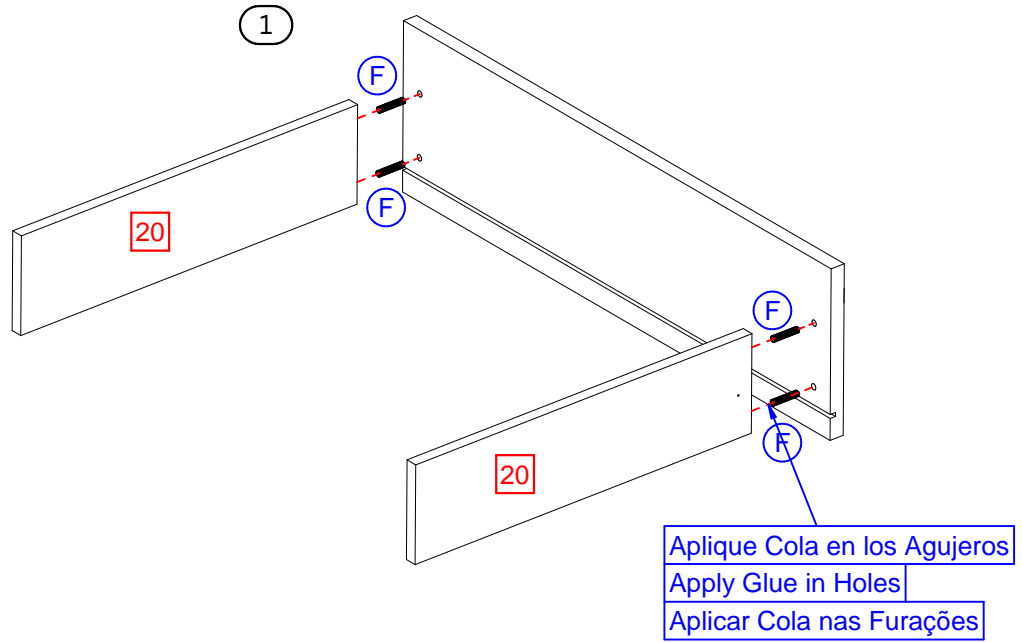

11

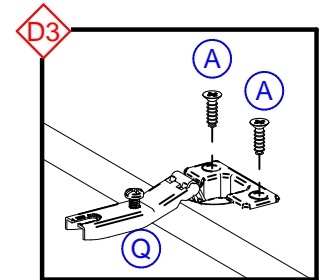
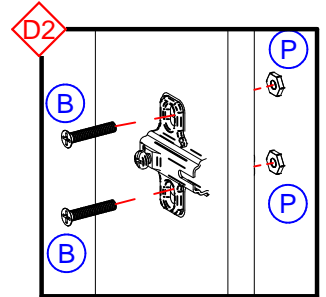
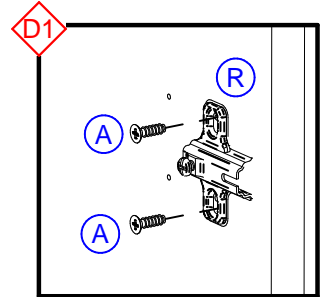
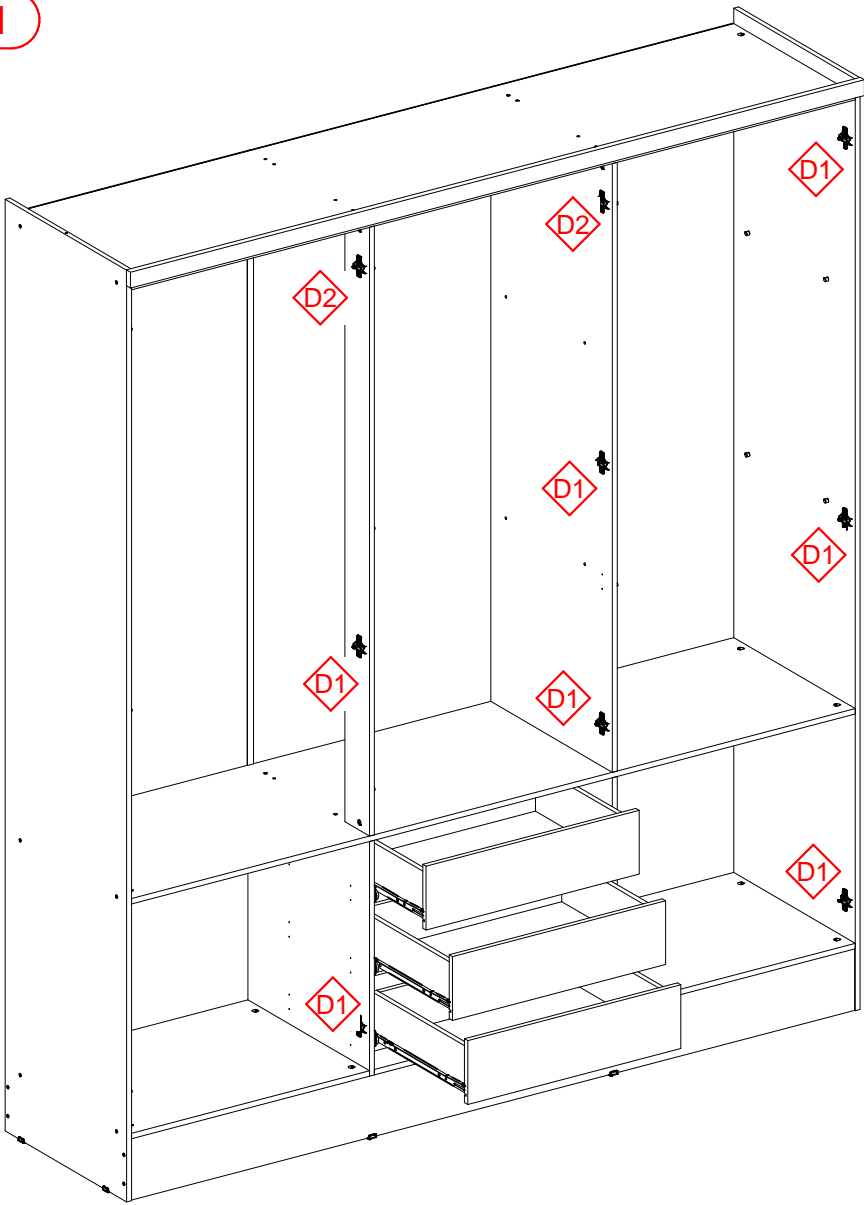

12

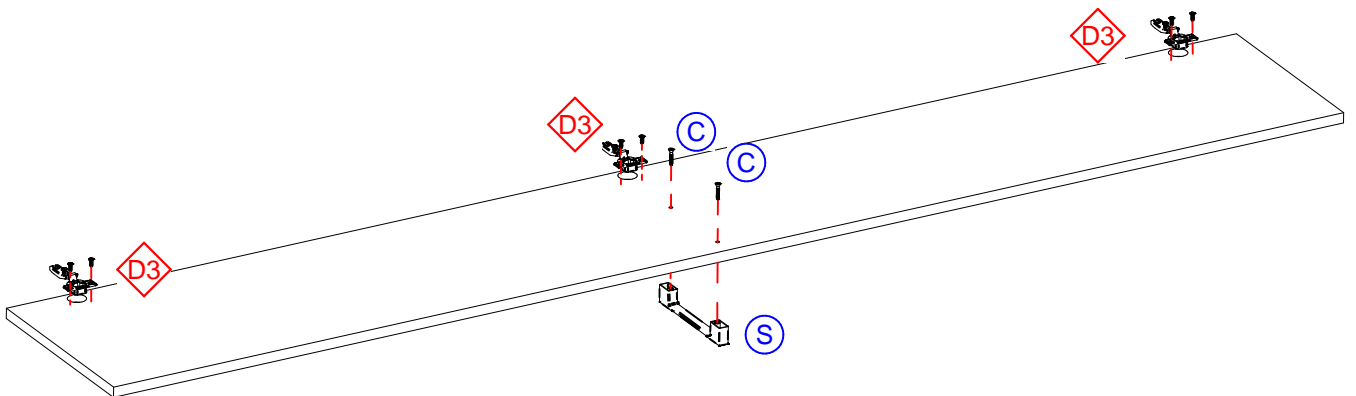

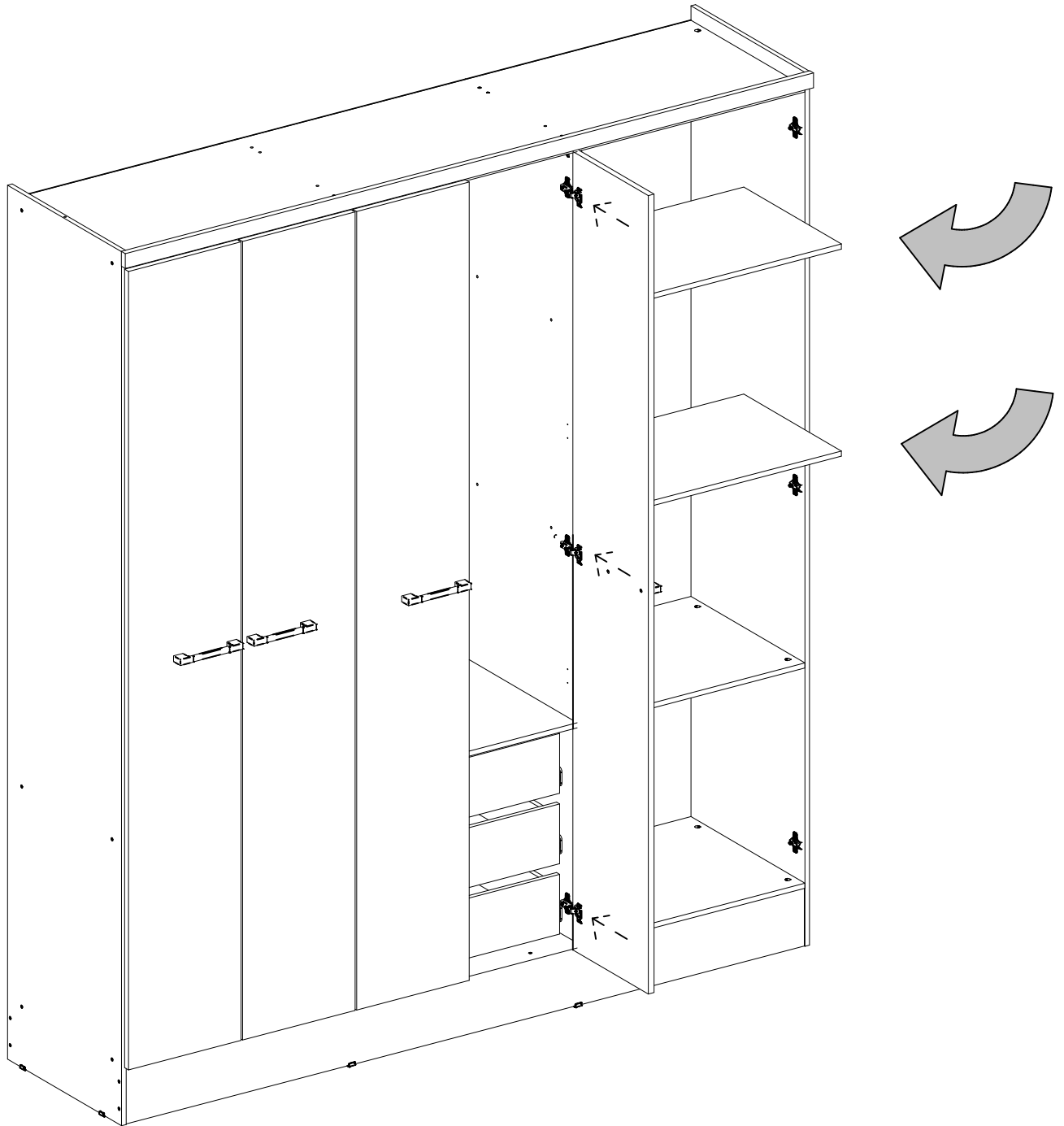

Ajuste das Portas / Door Adjustment / Ajuste de las Puertas

Encaixe da porta
Door setting
Encaje de la puerta

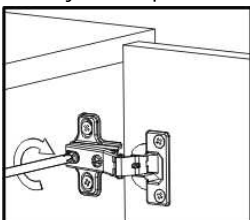

Ajuste de Altura
Height Adjustment
Ajuste del alto

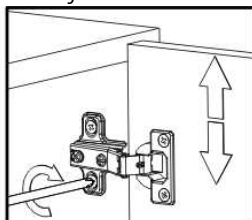

Ajuste Interno
Internal Adjustment
Ajuste Interno

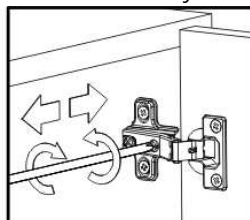

Ajuste de Profundidade
Depth Adjustment
Ajuste de la profundidad

