

REFERÊNCIA DO MODELO
PH-1738 ROUPEIRO 2 PORTAS DE CORRER

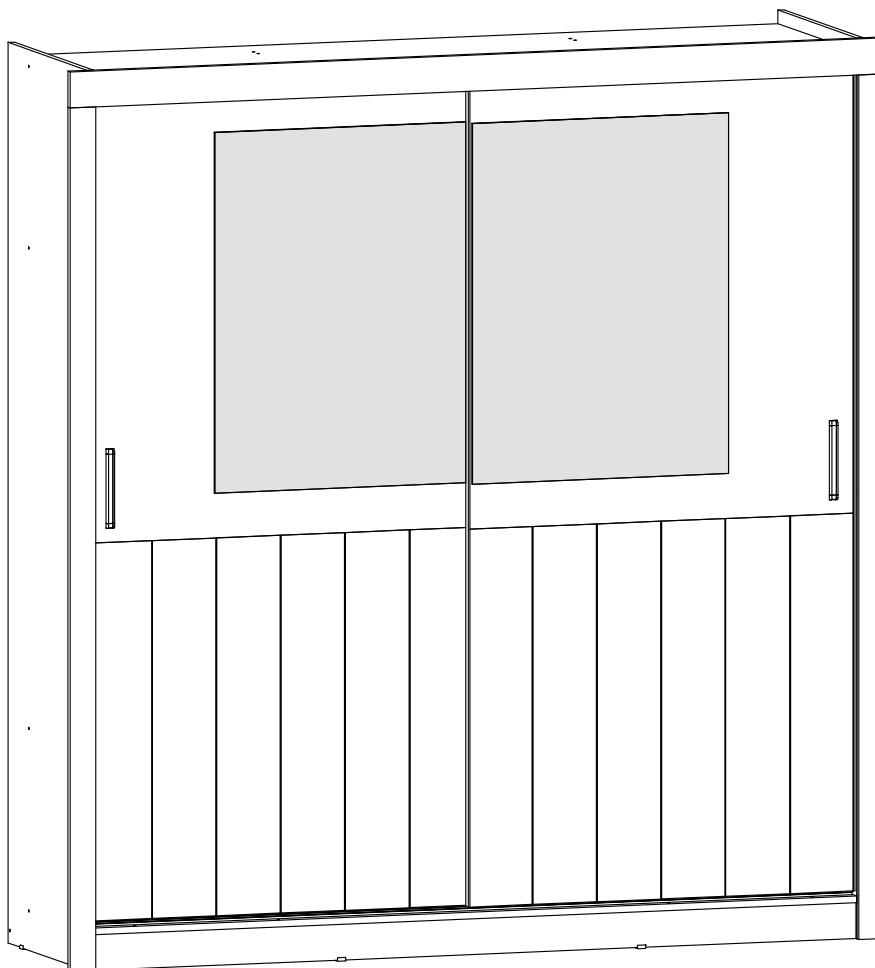

Atenção / Attention / Atención

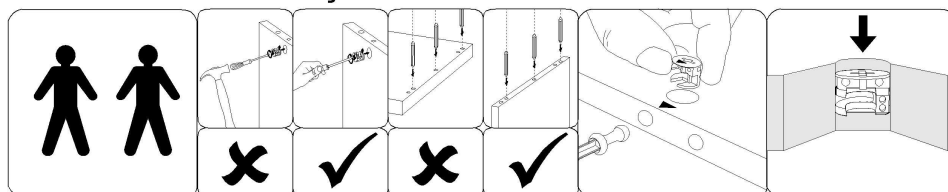

Informações ao cliente

Garantia de 06 meses, sendo 03 meses conforme o código de defesa do consumidor, e mais 03 meses por garantia do fabricante. Nos reservamos no direito de efetuar alterações nos produtos, sem aviso prévio, quando entender necessário.

Assistência
HERVAL
3564.8330
assistencia@herval.com.br
www.herval.com.br

EXPLOÇÃO DAS PEÇAS

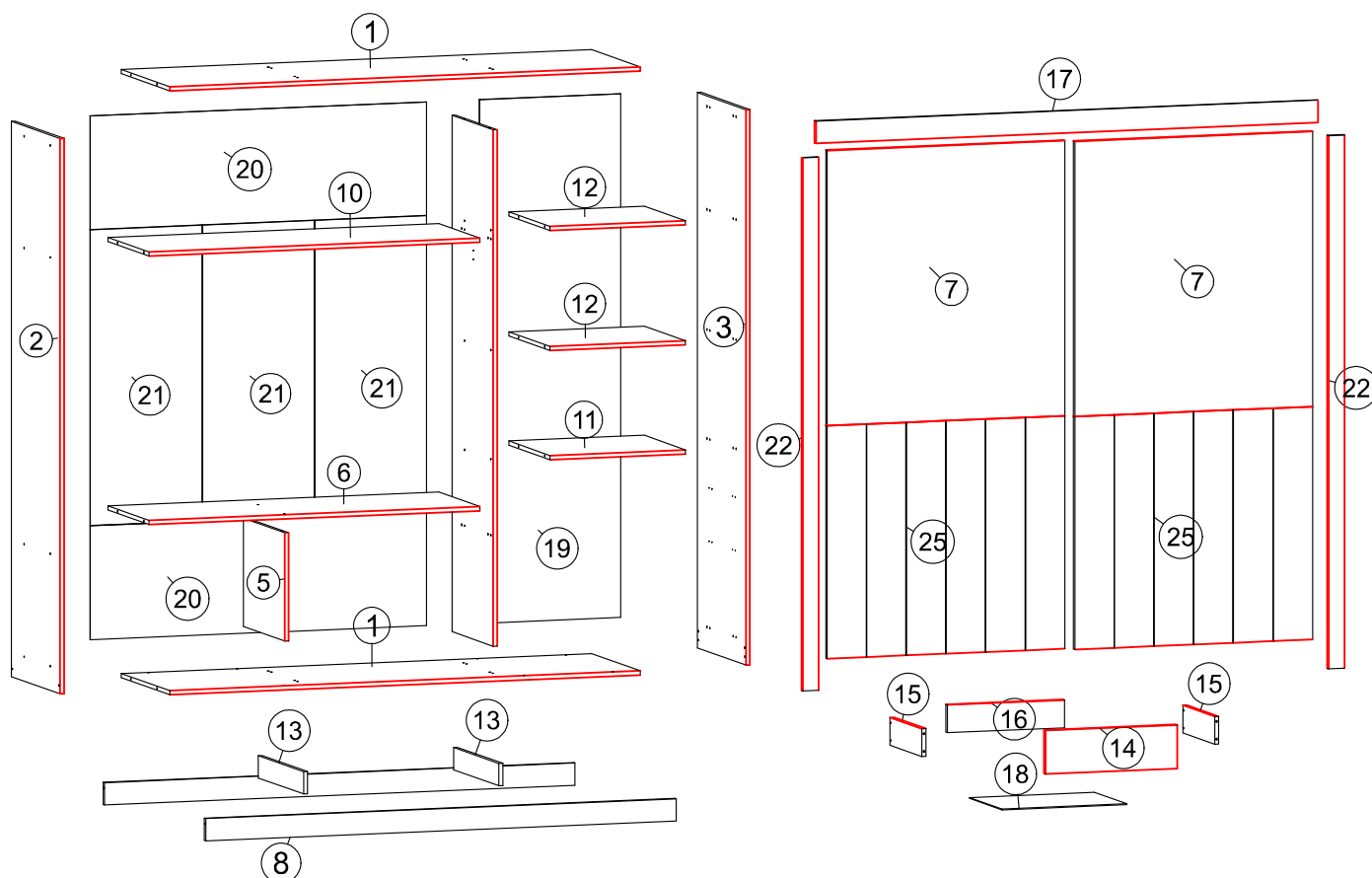

LISTA DE PEÇAS

VOLUME-1

N°	CÓDIGO	PEÇA	MEDIDA	QTDE
2	158585E	LATERAL ESQUERDA	2000.0x535.0x15.0	1
3	158586E	LATERAL DIREITA	2000.0x535.0x15.0	1
4	158587L	DIVISÃO	1860.0x452.0x15.0	1
5	158588L	DIVISÃO MENOR	390.0x452.0x15.0	1
11	158589L	TAMPO GAVETEIRO	513.0x452.0x15.0	1
16	158590L	TRASEIRO GAVETA	443.0x100.0x15.0	2
17	158591E	VISTA SUPERIOR	1900.0x80.0x15.0	1
18	158592L	FUNDO GAVETA	471.0x357.0x3.0	2
19	158593L	FUNDO MAIOR	1886.0x533.0x3.0	1
20	158594L	FUNDO INFERIOR	1272.0x410.0x3.0	2
21	158595L	FUNDO MEIO	1066.0x422.3x3.0	3
22	158597E	VISTA LATERAL	1920.0x60.0x15.0	2
27	1608457	PERFIL I 1052X20x3,8MM CINZA CIMENTO 053	1052.0x17.0x6.0	2
28	1608458	TUBO OBLONGO 1242MM	1242.0x30.0x15.8	1
29	1608455	PF AL FOSCO SG2013 1830MM C 8F ANODIZADO	1830.0x15.0x18.0	4
30	1608465	PUXADOR SILKY BAS 160MM ANOD PRATA	176.0x18.0x8.5	2
31	1606930	SIST JM 135 GUIA FOLGA ZERO	xx	2
34	1601800	CORREDICA NORMAL 350MM	xx	2

VOLUME-2

N°	CÓDIGO	PEÇA	MEDIDA	QTDE
1	158584E	TAMPO-BASE	1780.0x535.0x15.0	2
6	158598L	PRATELEIRA MAIOR	1252.0x452.0x15.0	1
8	158600E	RODAPÉ FRONTAL	1780.0x80.0x15.0	1
9	158601E	RODAPÉ TRASEIRO	1780.0x80.0x15.0	1
10	158602L	MALEIRO	1252.0x452.0x15.0	1
12	158603L	PRATELEIRA FIXA	513.0x452.0x15.0	2
13	158604E	TRAVESSA RODAPÉ	497.0x80.0x15.0	2
14	158605L	FRENTE GAVETA	498.0x157.0x15.0	2
15	158606L	LATERAL GAVETA	350.0x100.0x15.0	4
32	1606936	PERFIL AL INF SG3061 1775MM C FURACAO	1775.0x42.0x5.2	1
33	1606937	PERFIL PLAST SUP E28 1775MM	1775.0x60.0x24.0	1











LISTA DE PEÇAS**VOLUME-3**

N°	CÓDIGO	PEÇA	MEDIDA	QTDE
7	158608L	PORTA SUPERIOR	991.0x900.0x15.0	2
25	158607L	PORTA INFERIOR	839.0x900.0x15.0	2

KIT ESPELHOS**OPCIONAL****Cód.: 1608452**

LETRA	CÓDIGO	PEÇA	MEDIDA	QTDE
-	-	ESPELHO 3MM	801.0x598.0x3.0	2

KIT ACESSÓRIOS**CÓD.: K072557**

INDICE	PEÇA	IMAGE	CÓDIGO	QTDE
A	CANTONEIRA 18x18 (ZB)		1604301	13
B	CANTONEIRA 20x20x42mm (08.02.096)		-	8
C	CAVILHA DE MADEIRA 6X40		1604742	48
D	DISTANCIADOR DE CORREDIÇA 15MM		-	4
E	FIXADOR PARA COSTAS ZINCO BR		1601469	28
F	PARAFUSO 3 X 20 CAB. CHATA PHILIPS		1604857	8
G	PARAFUSO 4 X 14 CAB. CHATA REBAIXADA PHILIPS		1602420	86
G1	GIZ CERA NOG-CEDRO-FENDI-FREIJÓ Ø14x8MM		XXXXXXXX	1
G2	GIZ CERA BRANCO Ø14x8MM		XXXXXXXX	1
G4	GIZ CERA OFF WHITE - CINZA BP - LÍNEO Ø14x8MM		XXXXXXXX	1
G5	GIZ CERA CARVALHO VERMONT Ø14x8MM		XXXXXXXX	1
H	PARAFUSO 4 X 40 CAB. CHATA PHILIPS		1604937	56
I	PREGO 10 X 10 C/CABEÇA - Ø1,5 x 23mm		1605365	106
J	SAPATA QUADRADA 15x15mm (CINZA)		1602714	8
K	SUPORTE (04 04 059)		-	10
L	SUPORTE TUBO OBLONGO PLÁSTICO		1603790	2
M	TAPA FURO ADESIVO PAPEL 15mm		-	4
N	PARAFUSO 3.5 X 14 CAB. CHATA PHILIPS		1607861	48
O	PARAFUSO 3.5 X 20 CAB. FLANGEADO		-	4
P	PARAF. CORREDICA 6X10 PHILLIPS		XXXXXX	4

PASSO 1

PEÇAS NECESSÁRIAS

INDICE	QUANT.
2	1
3	1
34	2

FERRAGEM NECESSÁRIA

QTDE	IMAGEM	INDICE
4		D
14		G
4		I
4		J
2		L
4		P

PEÇAS NECESSÁRIAS

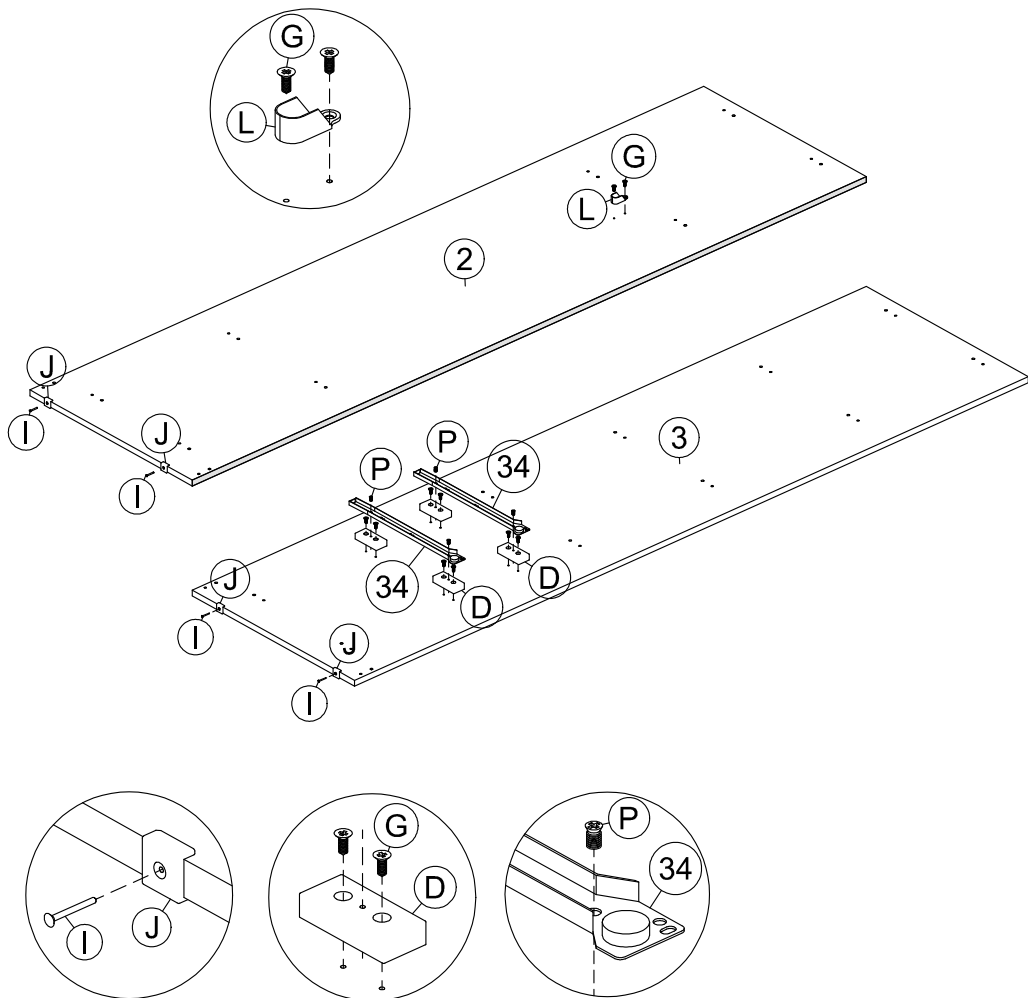

PASSO 2

INDICE	QUANT.
4	1
5	1
34	2

FERRAGEM NECESSÁRIA

QTDE	IMAGEM	INDICE
8		C
6		G
1		L

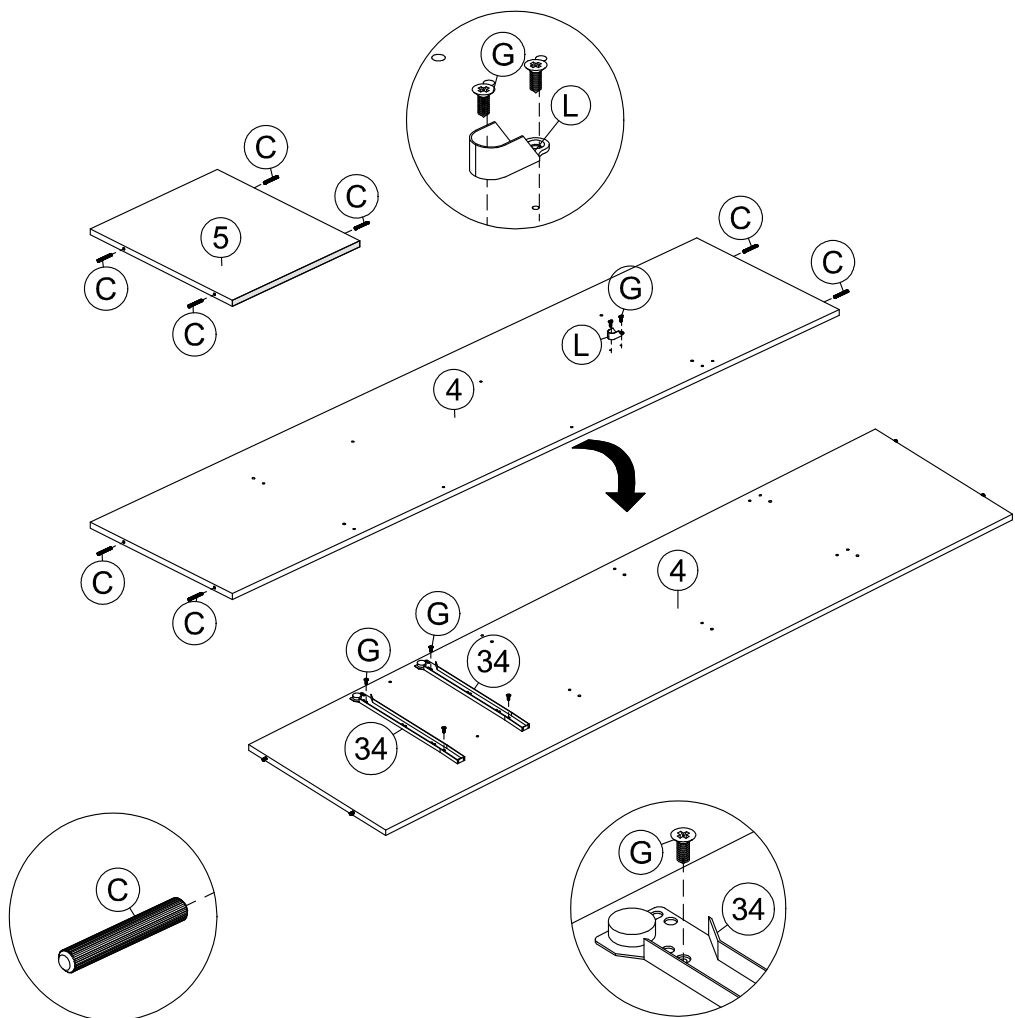

PASSO 3

PEÇAS NECESSÁRIAS

INDICE	QUANT.
1	2
6	1
10	1
11	1
12	2

FERRAGEM NECESSÁRIA

QTDE	IMAGEM	INDICE
28	—	C

PEÇAS NECESSÁRIAS

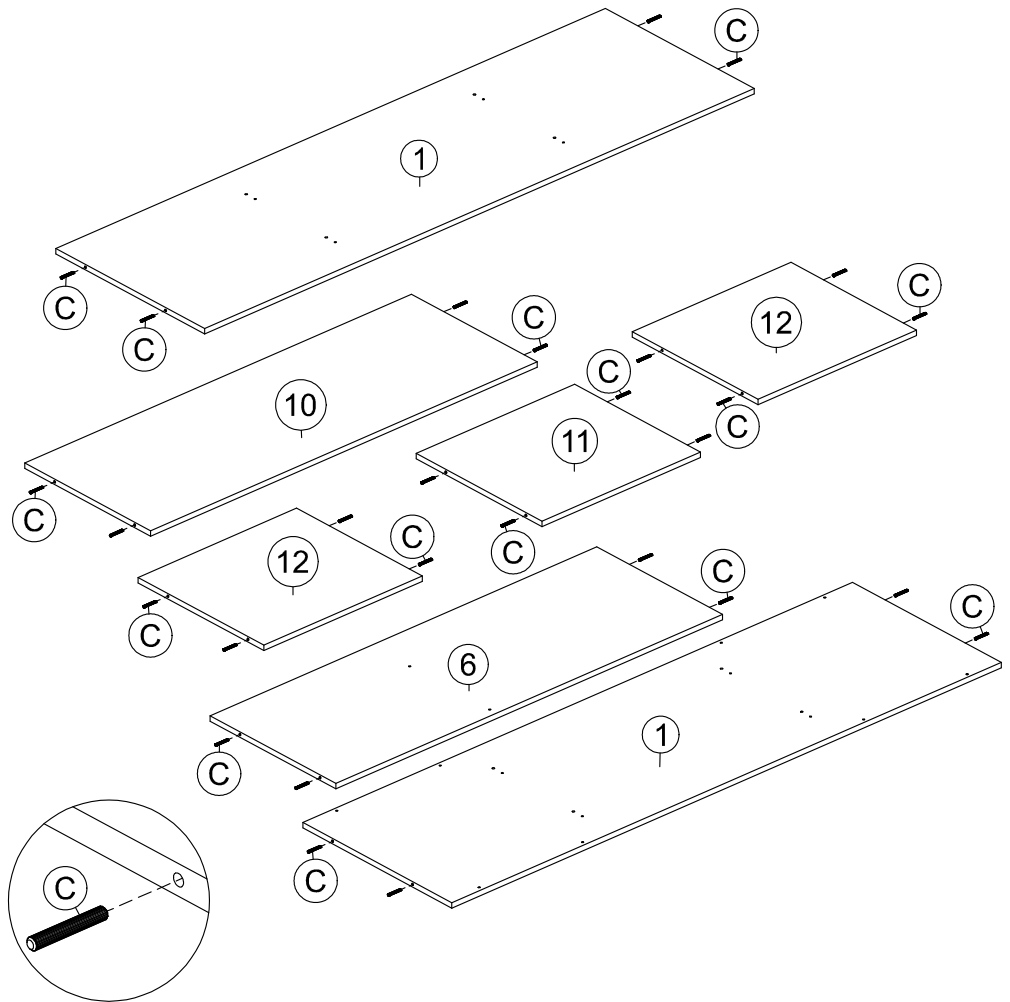

PASSO 4

INDICE	QUANT.
8	1
9	1
13	2

FERRAGEM NECESSÁRIA

QTDE	IMAGEM	INDICE
4		A
4	—	C
8		G
4		I
4		J

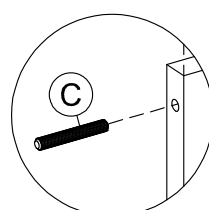
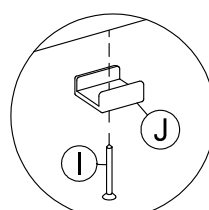
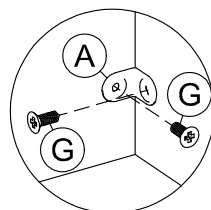
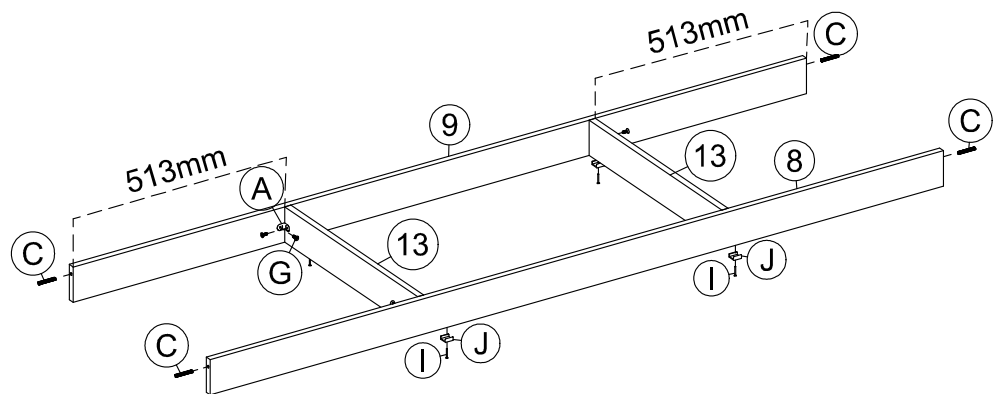

PASSO 5

PEÇAS NECESSÁRIAS

INDICE	QUANT.
1	1

FERRAGEM NECESSÁRIA

QTDE	IMAGEM	INDICE
12		H

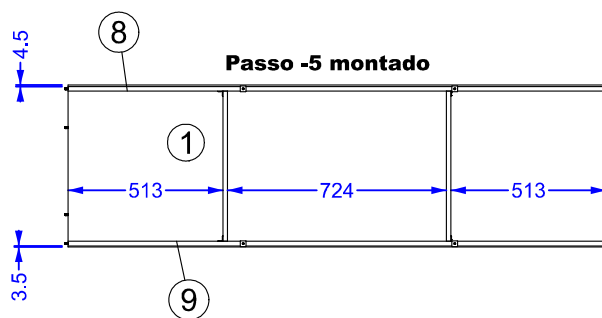
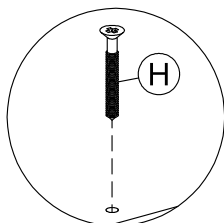
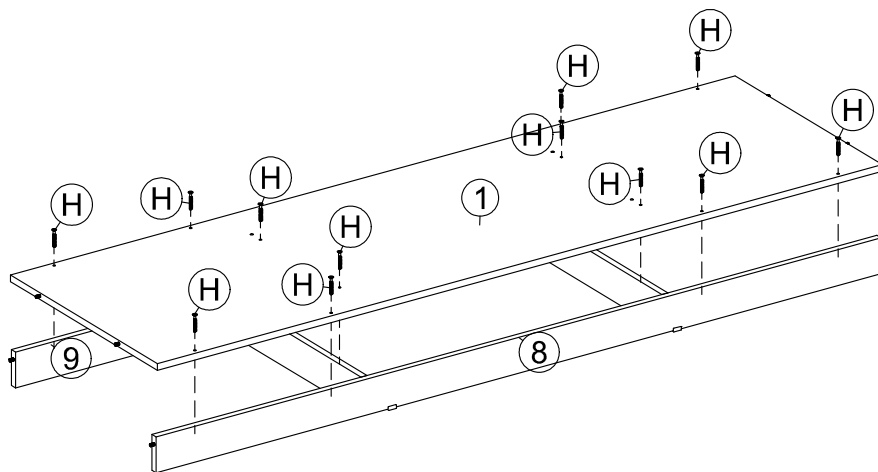

PEÇAS NECESSÁRIAS

PASSO 6

INDICE	QUANT.
3	1
4	1
11	1
12	2

FERRAGEM NECESSÁRIA

QTDE	IMAGEM	INDICE
16		H

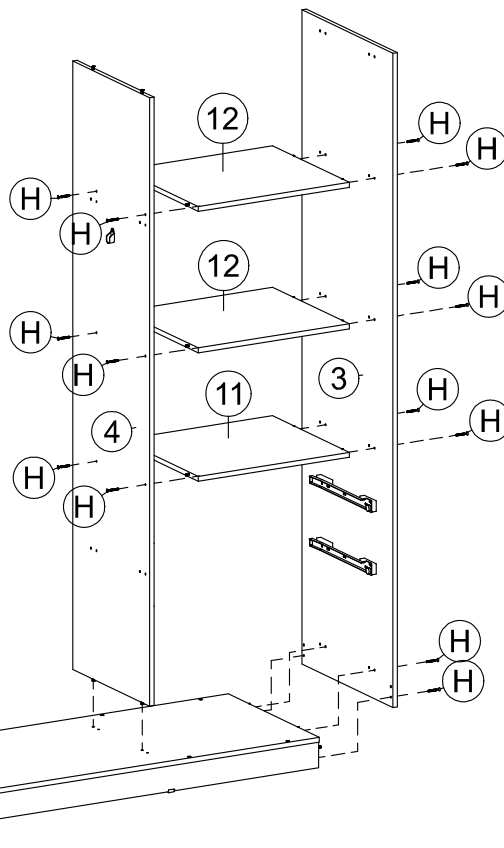
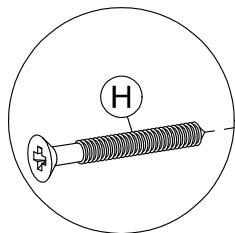

PASSO 7

PEÇAS NECESSÁRIAS

INDICE	QUANT.
5	1
6	1

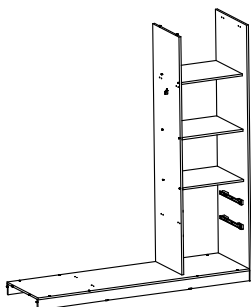

FERRAGEM NECESSÁRIA

QTDE	IMAGEM	INDICE
4		H

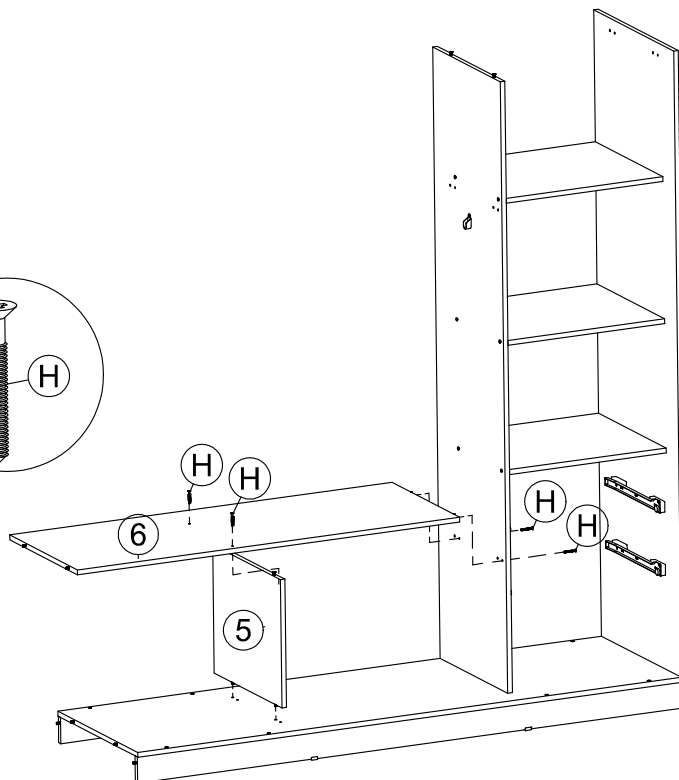
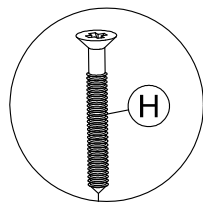

PEÇAS NECESSÁRIAS

PASSO 8

INDICE	QUANT.
2	1

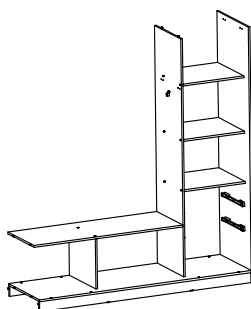

FERRAGEM NECESSÁRIA

QTDE	IMAGEM	INDICE
10		H

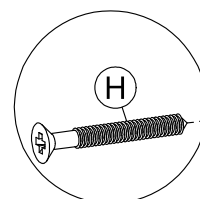
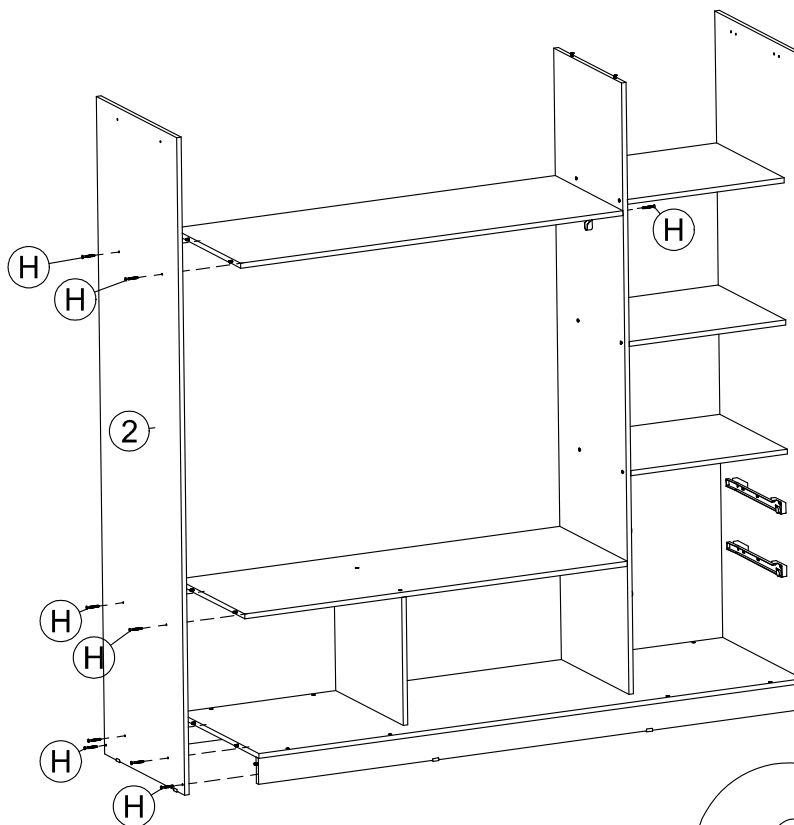

PASSO 9

PEÇAS NECESSÁRIAS

INDICE	QUANT.
1	1

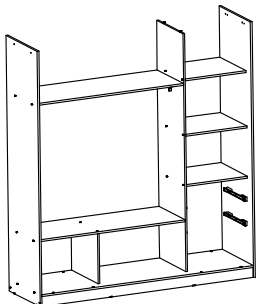

FERRAGEM NECESSÁRIA

QTDE	IMAGEM	INDICE
6		H

PEÇAS NECESSÁRIAS

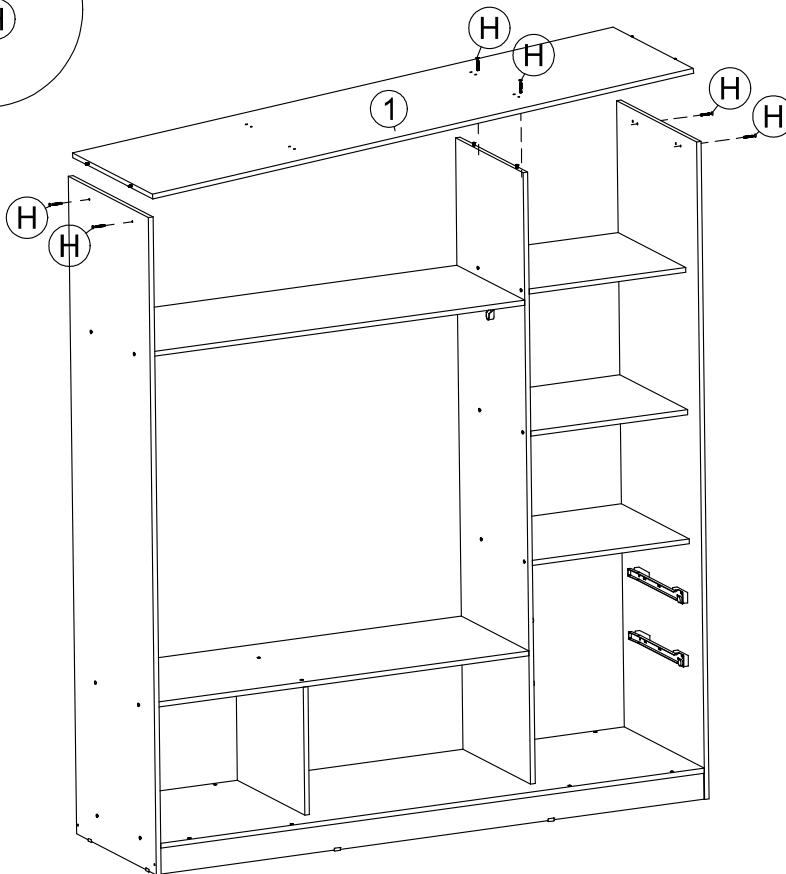
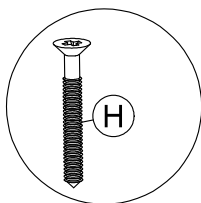

PASSO 10

INDICE	QUANT.
19	1
20	2
21	3
27	2

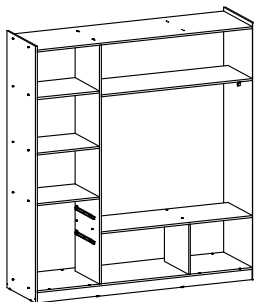

FERRAGEM NECESSÁRIA

QTDE	IMAGEM	INDICE
28		E
48		I

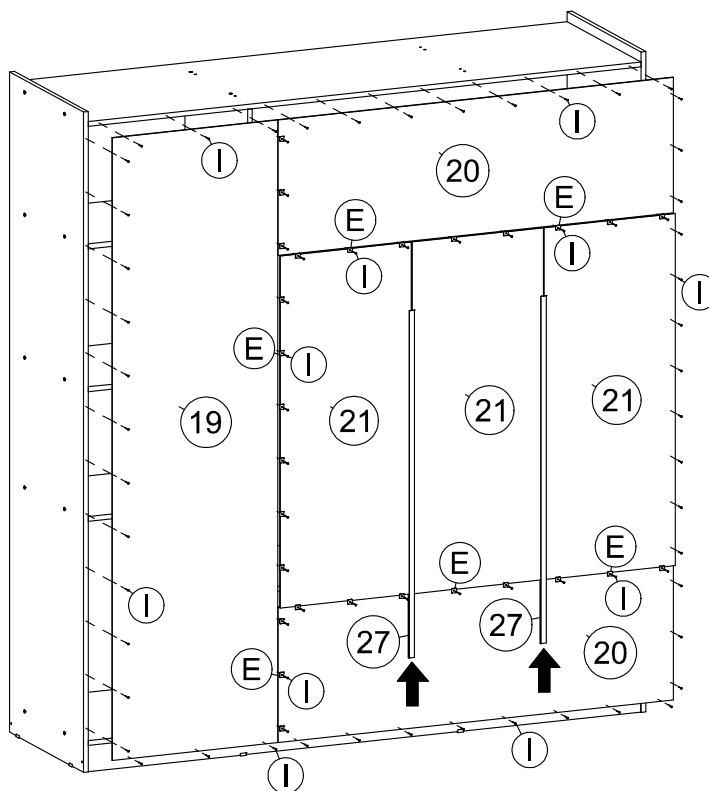
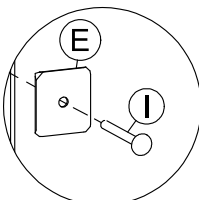
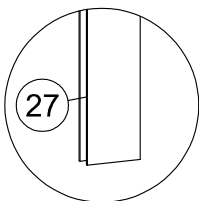

PASSO 11

PEÇAS NECESSÁRIAS

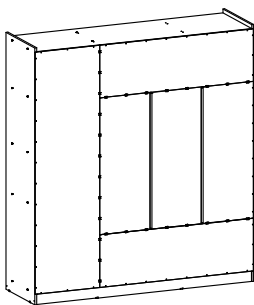

FERRAGEM NECESSÁRIA

QTDE	IMAGEM	INDICE
12		I

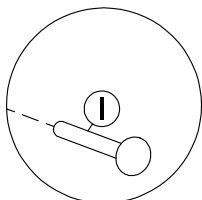
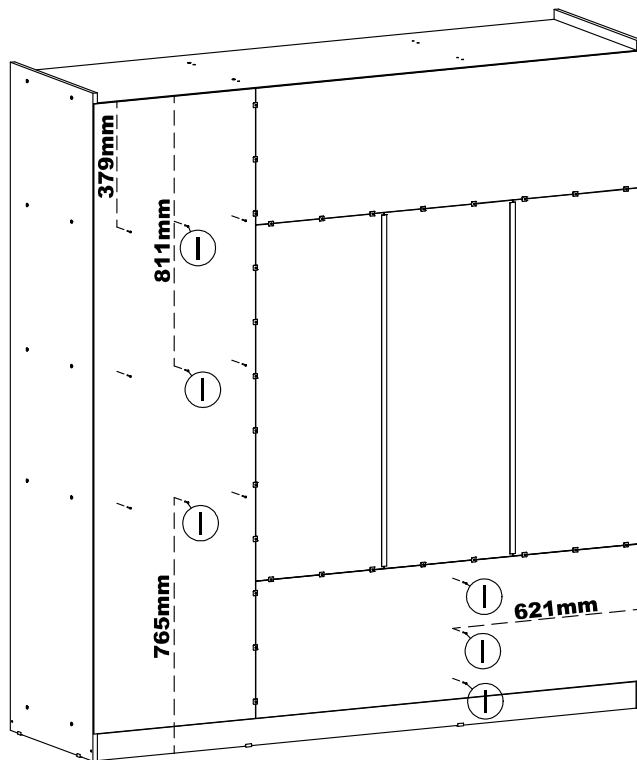

PEÇAS NECESSÁRIAS

PASSO 12

INDICE	QUANT.
28	1

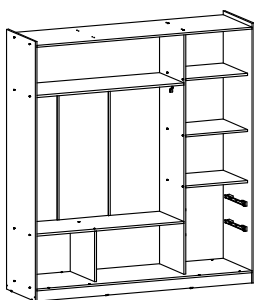

FERRAGEM NECESSÁRIA

QTDE	IMAGEM	INDICE
5		A
8		B
21		G

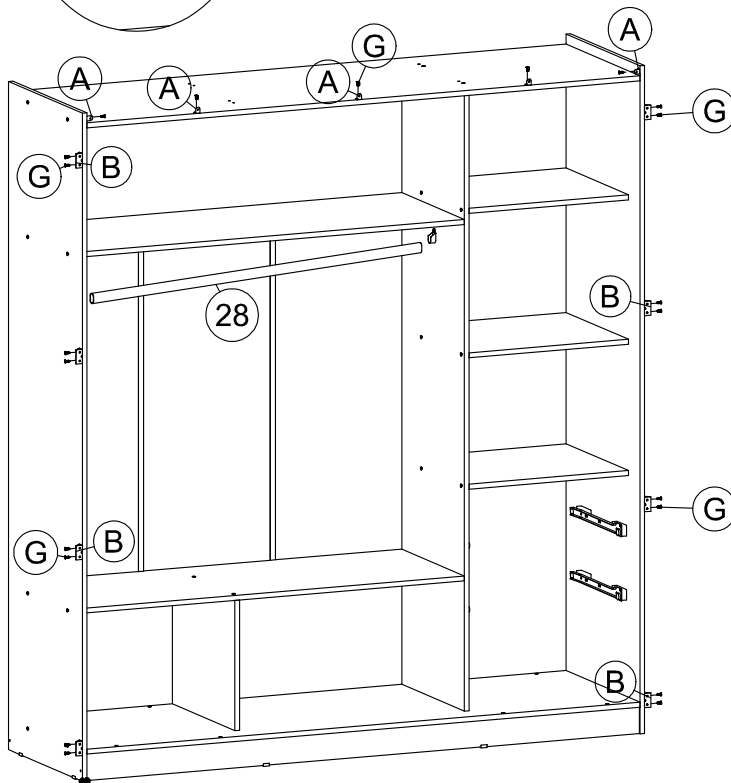
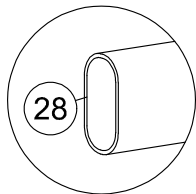
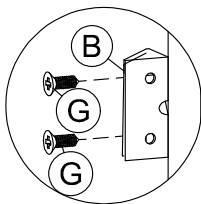
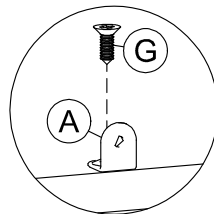

PASSO 13

PEÇAS NECESSÁRIAS

INDICE	QUANT.
17	1
22	2

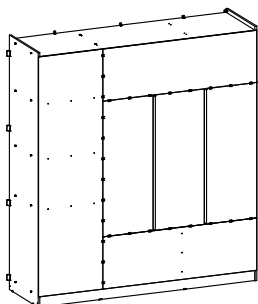

FERRAGEM NECESSÁRIA

QTDE	IMAGEM	INDICE
25		G
2		K

PEÇAS NECESSÁRIAS

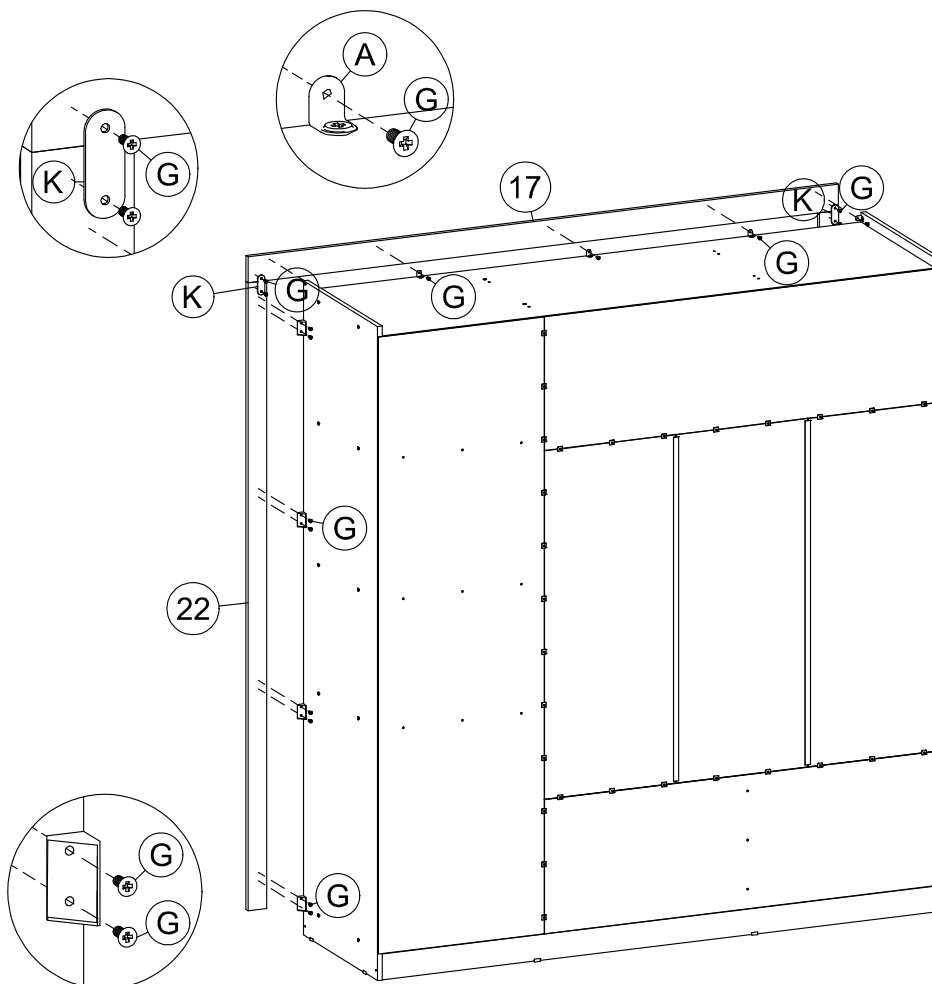

PASSO 14

INDICE	QUANT.
32	1
33	1

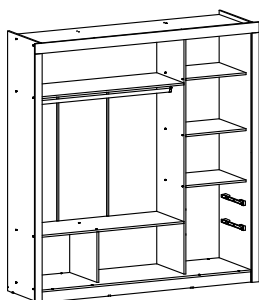

FERRAGEM NECESSÁRIA

QTDE	IMAGEM	INDICE
12		G

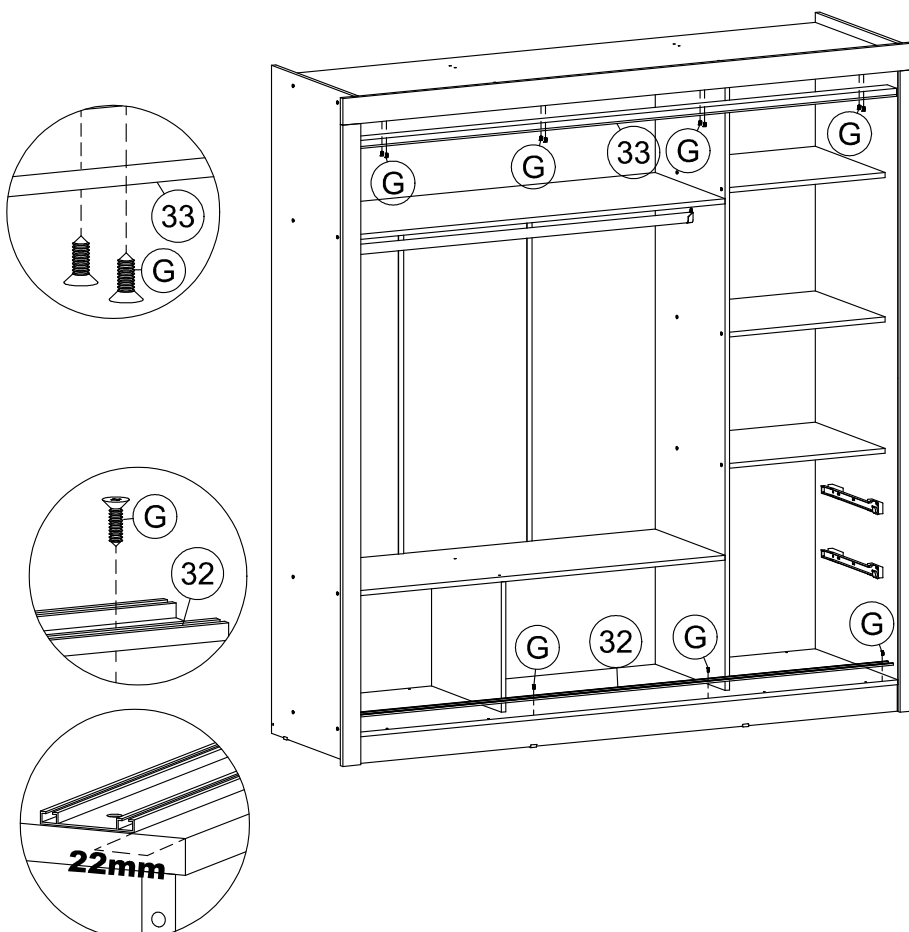



PASSO 15

PEÇAS NECESSÁRIAS

INDICE	QUANT.
14	2
15	4
16	2

FERRAGEM NECESSÁRIA

QTDE	IMAGEM	INDICE
4		A
8		G
8		H

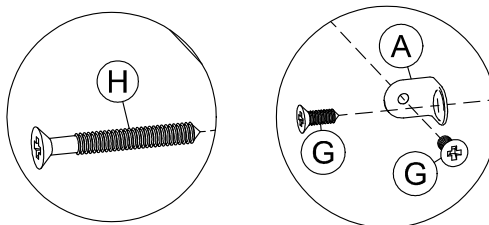
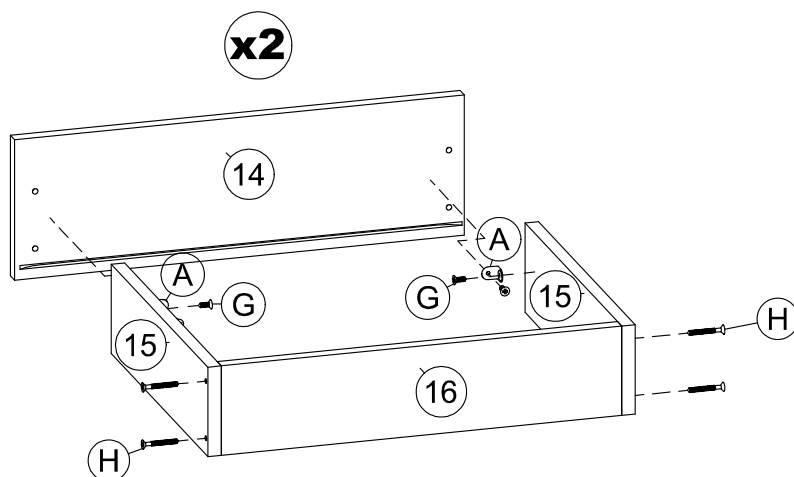

PEÇAS NECESSÁRIAS



PASSO 16

INDICE	QUANT.
18	2
34	4

FERRAGEM NECESSÁRIA

QTDE	IMAGEM	INDICE
8		F
10		I

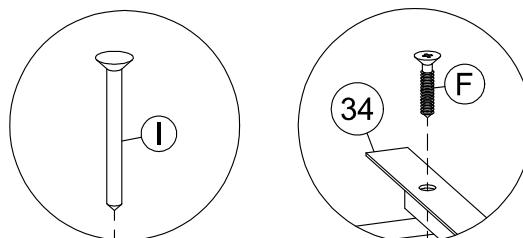
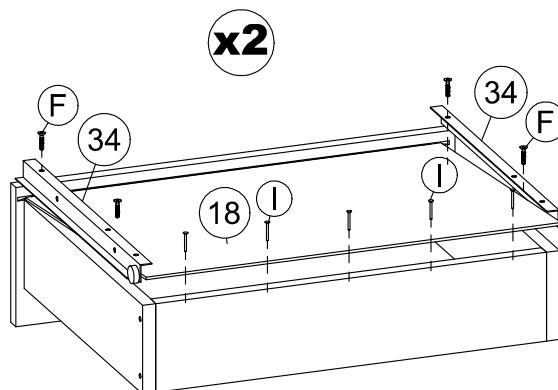

PASSO 17

PEÇAS NECESSÁRIAS

FERRAGEM NECESSÁRIA

PEÇAS NECESSÁRIAS

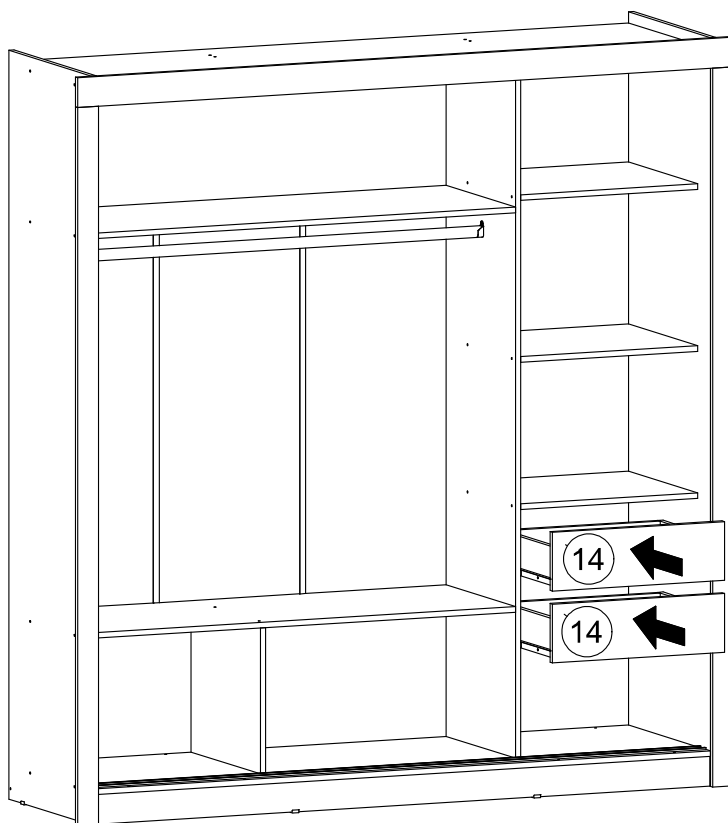

PASSO 18

Rotacionar a Porta Superior (26), para fazer o outro lado da Porta.

INDICE	QUANT.
7	2
25	2

FERRAGEM NECESSÁRIA

QTDE	IMAGEM	INDICE
16		G
8		K

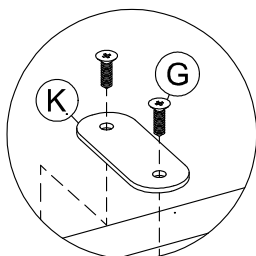
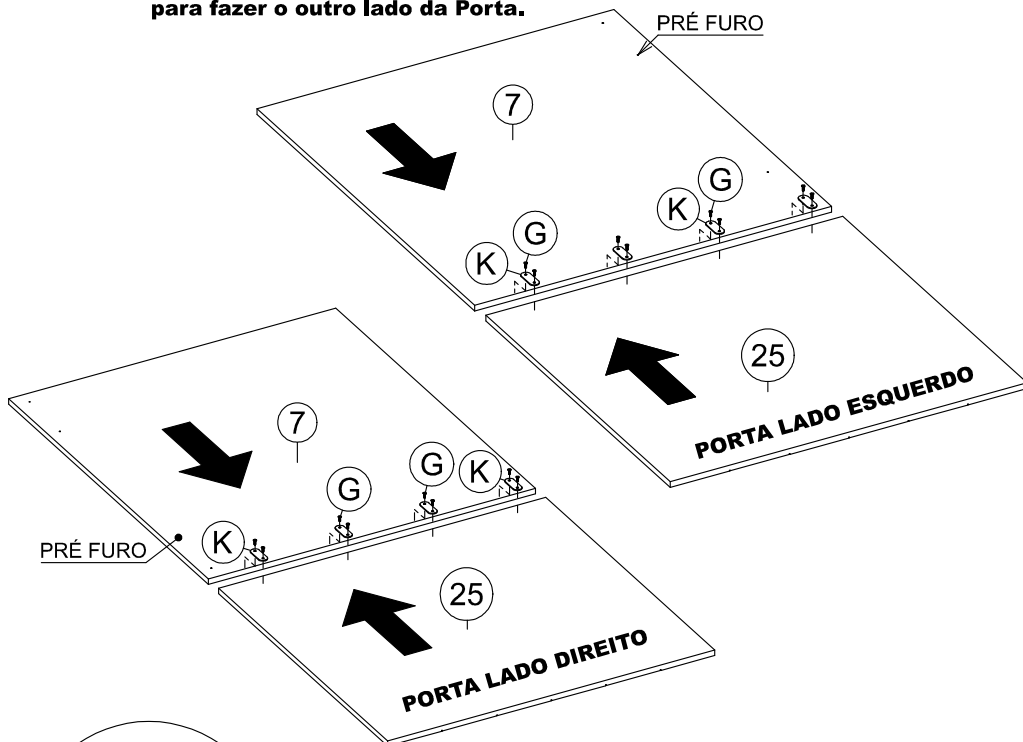

PASSO 19

PEÇAS NECESSÁRIAS

INDICE	QUANT.
29	4

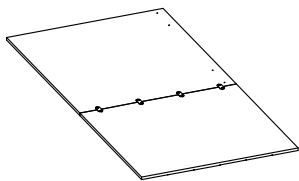

FERRAGEM NECESSÁRIA

QTDE	IMAGEM	INDICE
28		N

PEÇAS NECESSÁRIAS

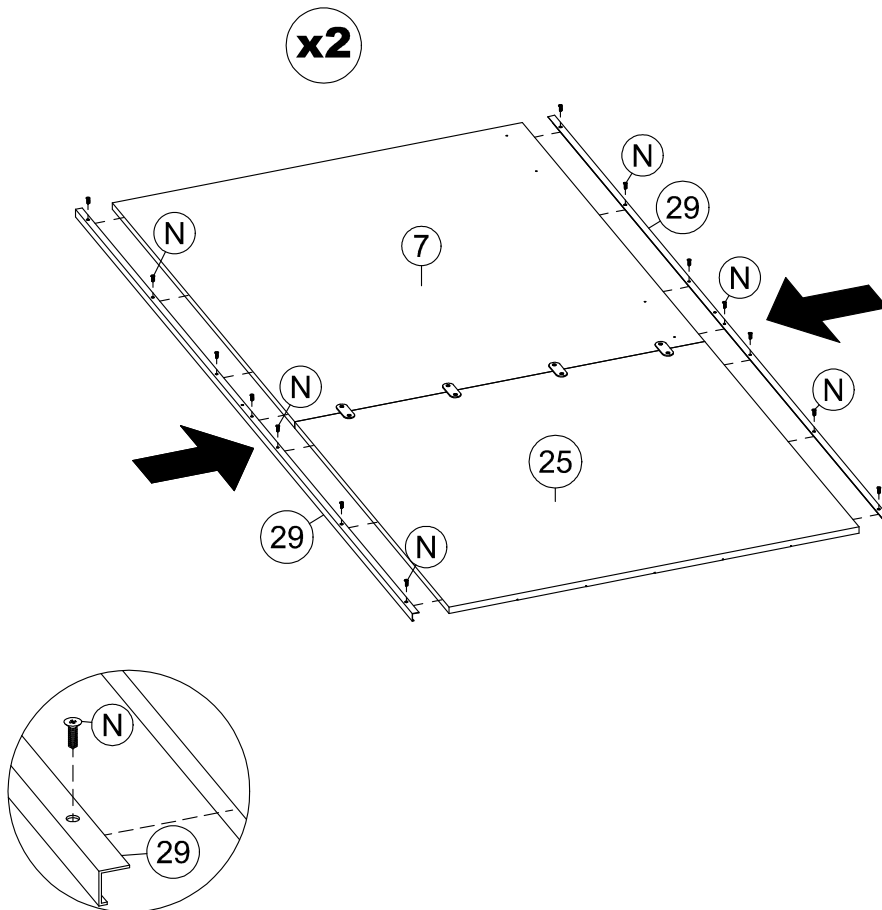

PASSO 20

INDICE	QUANT.
31	2

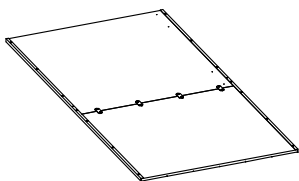

FERRAGEM NECESSÁRIA

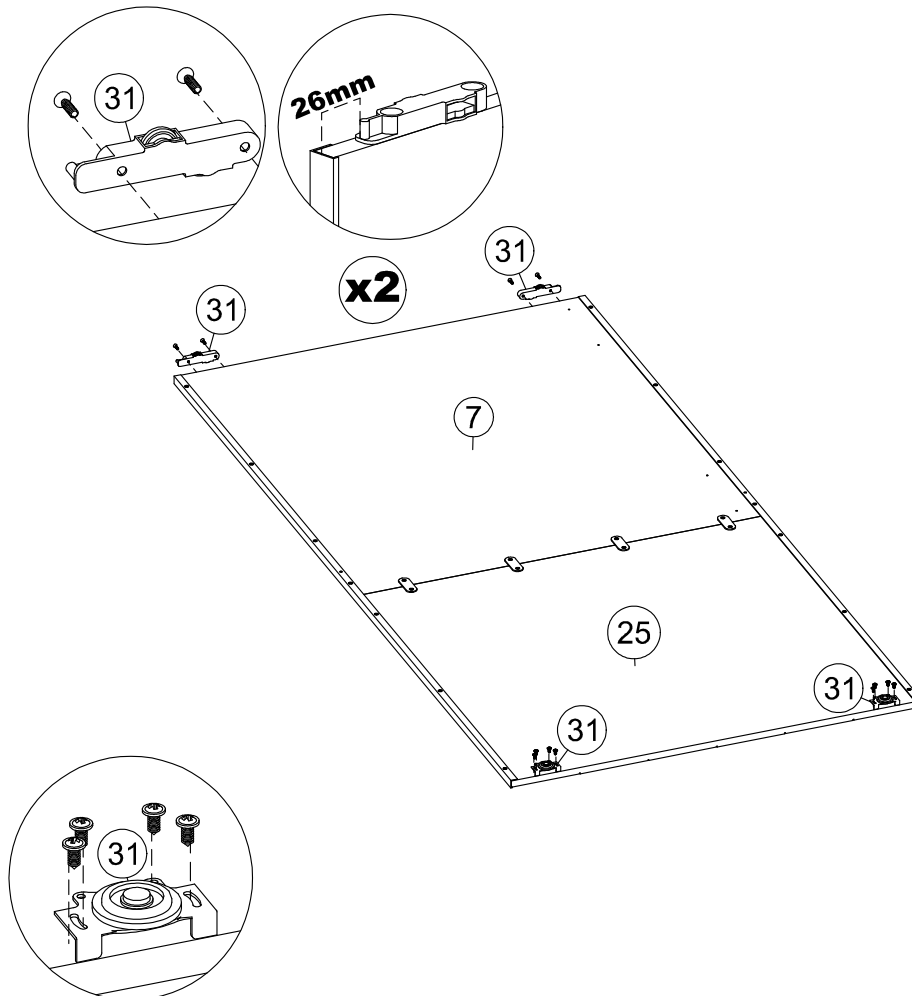



PASSO 21

PEÇAS NECESSÁRIAS

INDICE	QUANT.
30	2

FERRAGEM NECESSÁRIA

QTDE	IMAGEM	INDICE
2		-
4		O

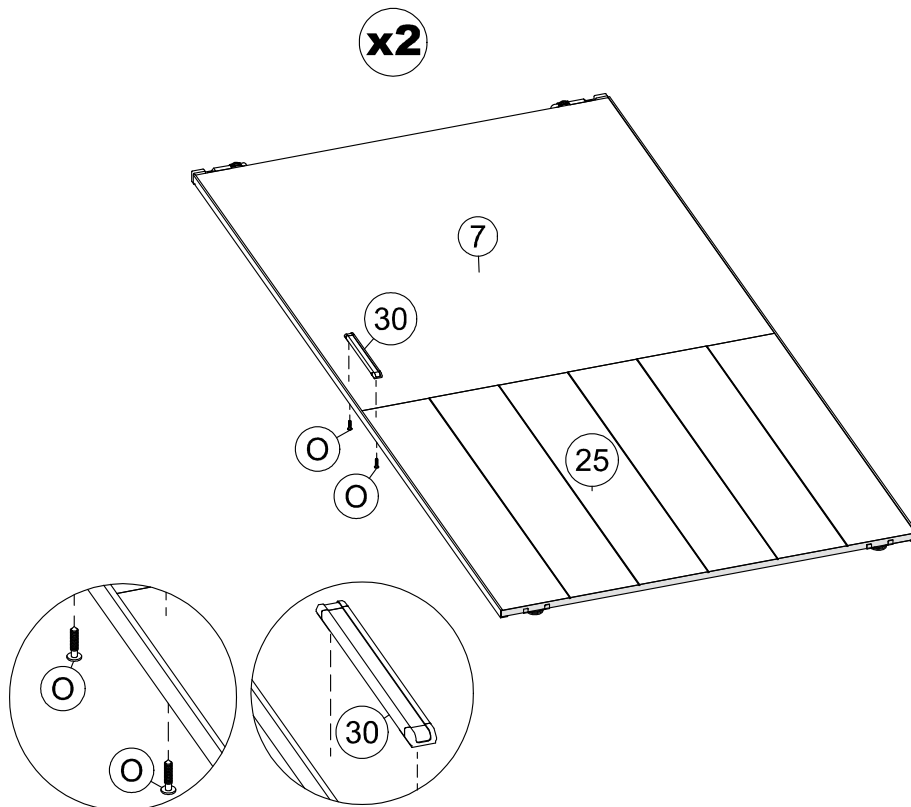

PASSO 22

PEÇAS NECESSÁRIAS

INDICE	QUANT.
31	2

FERRAGEM NECESSÁRIA

Atenção!
Fixar o Freio do Sistema de Correr
Conforme mostra o desenho abaixo.!

