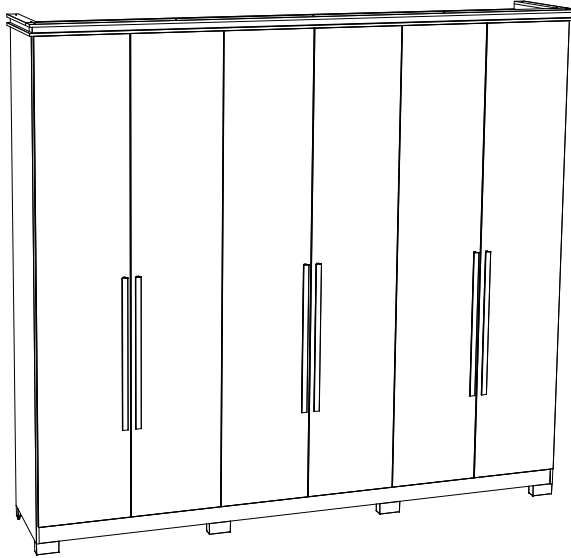
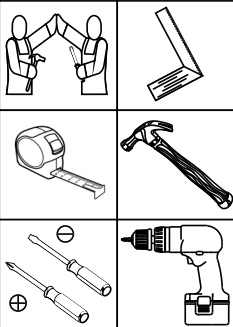

HENNInd. e Com. de Móveis Henn
Mondaiá - SC - Brasil

☎ +55 49 3674.3500

📷 @moveishenn
www.henn.com.br**INSTRUÇÕES DE
MONTAGEM****ROUPEIRO BÉLORI 06 PORTAS | ARMARIO BÉLORI 06 PUERTAS | WARDROBE
BÉLORI 06 DOORS**D303-127 Nature/Off White
D303-130 Castanho HP II**Requisitos para montagem
Requisitos para la montaje
Assembly Requirements**

Imagens meramente ilustrativas,
não acompanha o produto.
Imágenes ilustrativas, no incluidas
con el producto.
Illustrative images, not included
with the product.

Para limpeza de seu móvel, use uma flanela seca ou umedecida, e não utilize produtos químicos que possam danificar seu produto.

SISTEMA DE MONTAGEM

O sistema de montagem dos produtos, funciona de acordo com a ordem crescente dos números indicados no desenho. Ex.: 01, 02, 03, 04... até a conclusão da montagem.

ASSISTÊNCIA TÉCNICA

Para solicitação de Assistência Técnica você consumidor deverá entrar em contato com o Lojista a qual você realizou a compra deste produto e solicitar a assistência técnica das peças avariadas. A garantia abrange todas as peças, partes e componentes que eventualmente venham apresentar defeito de fabricação no prazo de 03 (três) meses, contando a partir da entrega do produto ao consumidor, mediante nota fiscal de compra. Se houver qualquer alteração na estrutura do produto ou ocorrer defeito por negligência do montador/consumidor em relação a instrução de montagem e manuseio, não será fornecido assistência técnica gratuita.

ADVERTENCIA

Para limpieza de su móvil, use una flanela seca o húmeda, y no utilice productos químicos que puedan dañar su producto.

SISTEMA DE MONTAJE

El sistema de montaje de los productos funciona de acuerdo con el orden creciente de los números indicados en el dibujo. Ej.: 01, 02, 03, 04... hasta la conclusión del montaje.

ASSISTÊNCIA TÉCNICA

Para solicitar Asistencia Técnica, el consumidor debe comunicarse con el Comercio que usted realizó la compra de este producto y solicita asistencia técnica para las partes dañadas. La garantía cubre todas las partes, piezas y componentes que eventualmente puedan presentar defecto de fabricación en el plazo de 03 (tres) meses, contados a partir de la entrega del producto al consumidor, mediante factura de compra. Si se produce algún cambio en la estructura del producto o se produce un defecto por negligencia del montador/consumidor en relación con las instrucciones de montaje y manipulación, no se prestará asistencia técnica gratuita.

NOTICE**ASSEMBLY SYSTEM**

The products' assembly system works according to the increasing order of the indicated numbers. For example: 01, 02, 03, 04 ... to the end of the assembly.

TECHNICAL ASSISTANCE

To request Technical Assistance, the consumer must contact the retailer from whom you purchased this product and request technical assistance for the damaged parts. The warranty covers all parts, parts and components that may eventually present a manufacturing defect within a period of 03 (three) months, counting from the delivery of the product to the consumer, by means of a purchase invoice. If there is any change in the structure of the product or defect occurs due to negligence of the assembler/consumer in relation to the assembly and handling instruction, free technical assistance will not be provided.

ACESSÓRIOS | ACCESORIOS | ACCESSORIES

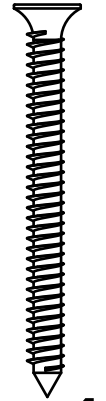

x4



x32



x8



x16



x18

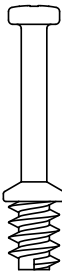

x3



x18



x10



x118



x82

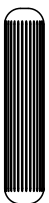

x118

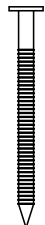

x10



x154

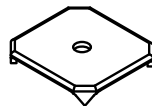

x46



x3

Parafusos em escala
Tornillos escalados
Scaled screws

1:1

ACESSÓRIOS | ACCESORIOS | ACCESSORIES

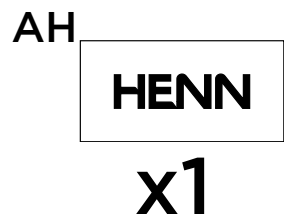
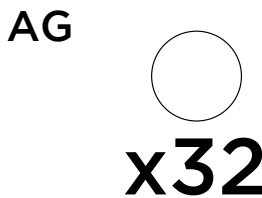
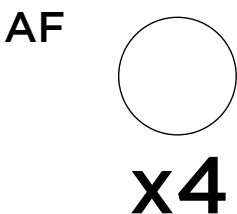
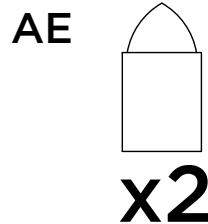
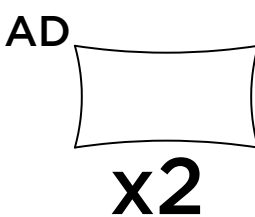
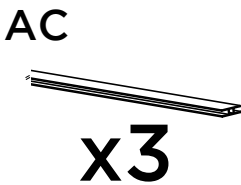
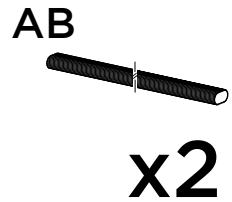
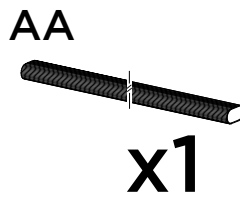
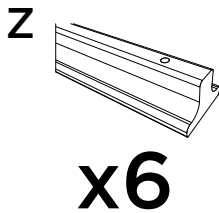
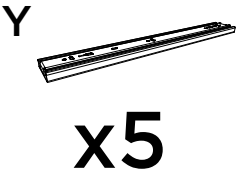
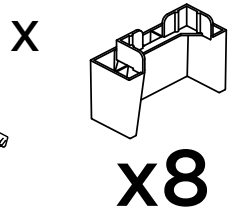
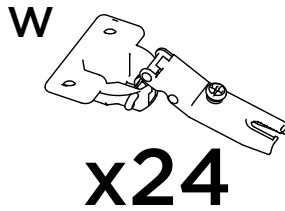
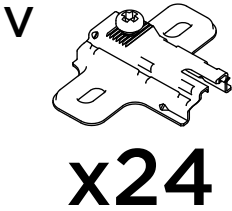
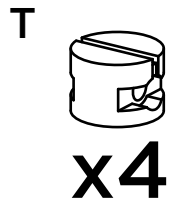
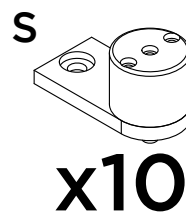
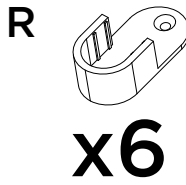
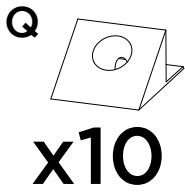

LISTA DE PEÇAS | LISTA DE PIEZAS | LIST OF PIECES

35Item	Caixa Caja Box	Qtd Ctd Qty	Descrição Descripción Description	Dimensões (mm) Dimensiones (mm) Dimensions (mm)		
				Comprimento Largo Length	Largura Ancho Width	Espessura Grosor Thickness
1	2/4	01	RODAPÉ FRONTAL PIE DE PÁGINA FRONTAL FRONT FOOTER	2463	73	12
2	2/4	02	TRAVESSA DO RODAPÉ RECORRIDO DE PIE DE PÁGINA FOOTER TRAVERSE	415	73	12
3	2/4	01	RODAPÉ TRASEIRO PIE DE PÁGINA POSTERIOR REAR FOOTER	2463	73	12
4	2/4	01	BASE BASE BASE	2463	445	12
5	3/4	01	LATERAL ESQUERDA LADO IZQUIERDO LEFT SIDE	2201	445	12
6	3/4	01	DIVISÃO MENOR DIVISIÓN MENOR MINOR DIVISION	1350	350	12
7	1/4	03	PRATELEIRA MENOR ESTANTE MÁS PEQUEÑO SMALLER SHELF	443	350	12
8	2/4	01	PRATELEIRA DA DIVISÃO ESTANTE DE DIVISIÓN DIVISION SHELF	813	350	12
9	1/4	01	DIVISÃO ESQUERDA DIVISIÓN IZQUIERDA LEFT DIVISION	1690	445	12
10	1/4	01	DIVISÃO DIREITA DIVISIÓN DERECHA RIGHT DIVISION	1690	445	12
11	3/4	01	TAMPO DAS GAVETAS PARTE SUPERIOR DE LOS CAJONES DRAWER TOPS	813	400	12
12	3/4	01	DIVISÃO DA COLMÉIA DIVISIÓN DE COLMENA HIVE DIVISION	778	350	12
13	1/4	02	PRATELEIRA DA COLMÉIA ESTANTE DE COLMENA BEEHIVE SHELF	400	350	12
14	3/4	01	LATERAL DIREITA LADO DERECHO RIGHT SIDE	2201	445	12
15	2/4	01	PRATELEIRA CALCEIRO ESTANTE CALCEIRO CALCEIRO SHELF	813	250	12
16	2/4	01	CHÃO DO MALEIRO PISO DEL MALETERO TRUNK FLOOR	2463	445	12
17	2/4	02	RIPA DO MALEIRO LISTÓN MALEIRO TRUNK SLAT	414	73	12
18	2/4	01	TAMPO CUBRIR COVER	2517	495	12
19	2/4	02	RIPA LATERAL LISTÓN LATERAL SIDE SLAT	873	58	25
20	2/4	01	MOLDURA FRONTAL MARCO FRONTAL FRONT FRAME	2487	60	25
21	2/4	02	MOLDURA LATERAL MARCO LATERAL SIDE FRAME	415	35	25
22	2/4	01	MOLDURA FRONTAL MAIOR MARCO FRONTAL MÁS GRANDE LARGER FRONT FRAME	2517	80	12
23	2/4	02	MOLDURA LATERAL MAIOR MARCO LATERAL MÁS GRANDE LARGER SIDE FRAME	415	50	12
24	2/4	01	FUNDO SUPERIOR FONDO SUPERIOR UPPER BOTTOM	2483	432	3
25	3/4	06	FUNDO FONDO BOTTOM	1707	410	3
26	4/4	06	PORTA PUERTA DOOR	2118	410	15
27	1/4	05	FRENTE DE GAVETA FRENTE DEL CAJÓN DRAWER FRONT	755	170	12
28	3/4	10	LADO DE GAVETA LADO DEL CAJÓN DRAWER SIDE	350	122	12
29	1/4	05	FUNDO DA GAVETA RECORTADO FONDO DE CAJÓN RECORTADO CROPPED DRAWER BOTTOM	730	361	3
30	1/4	05	RIPA DE TRÁS LISTÓN TRASERO BACK SLAT	743	122	12

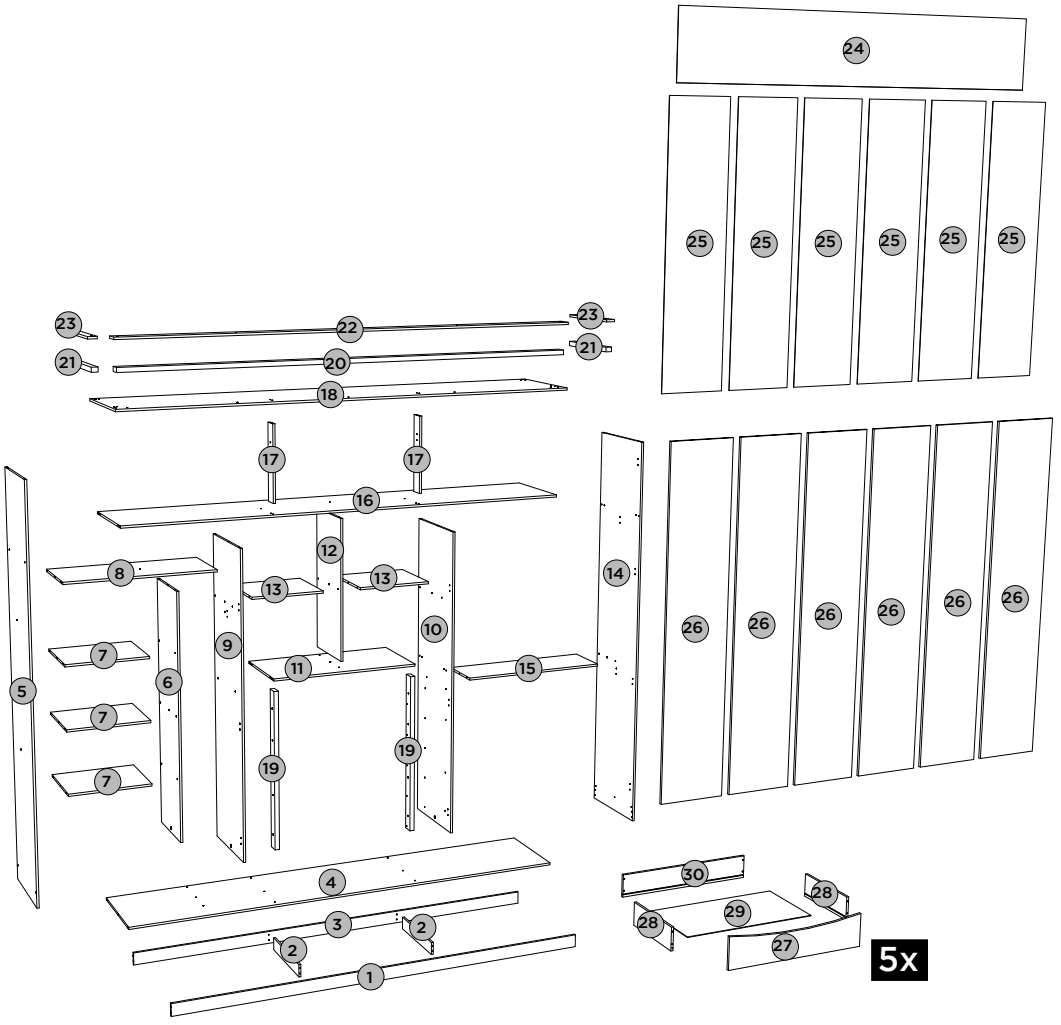

LISTA DE PEÇAS | LISTA DE PIEZAS | LIST OF PIECES



PEÇAS REQUERIDAS

1	RODAPÉ FRONTAL	x1
2	TRAVESSA DO RODAPÉ	x2
3	RODAPÉ TRASEIRO	x1
17	RIPA DO MALEIRO	x2

ACESSÓRIOS REQUERIDOS

I		04
K		20
P		04

FERRAMENTAS NECESSÁRIAS

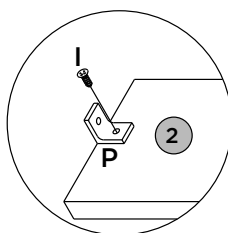
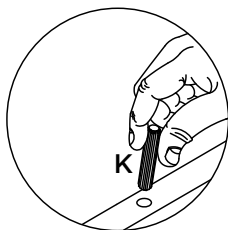
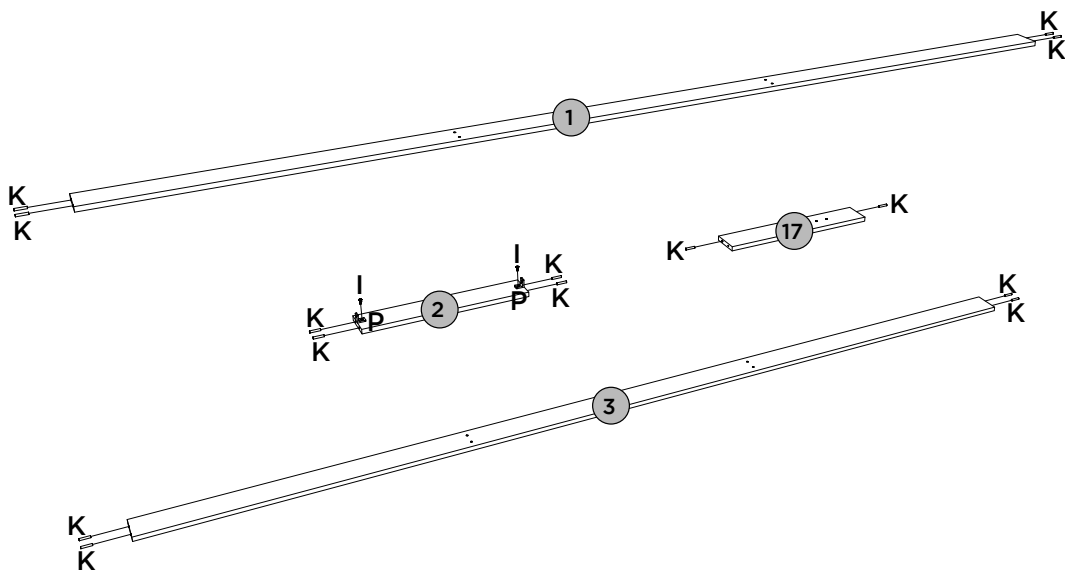
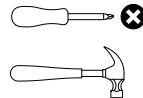





PASSO 2

ITM/D303-

PEÇAS REQUERIDAS

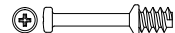
4	BASE	x1
5	LATERAL ESQUERDA	x1

ACESSÓRIOS REQUERIDOS

F		03
I		08
K		04
T		04
V		04



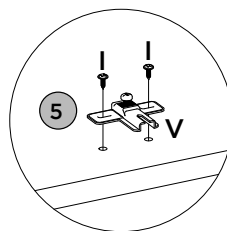
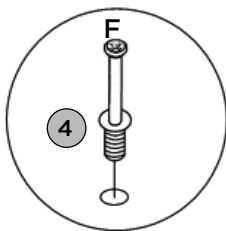
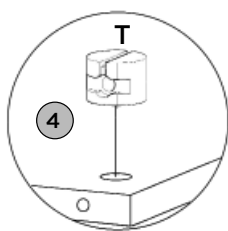
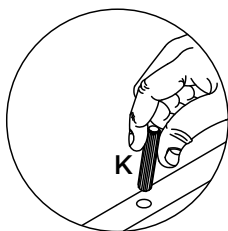
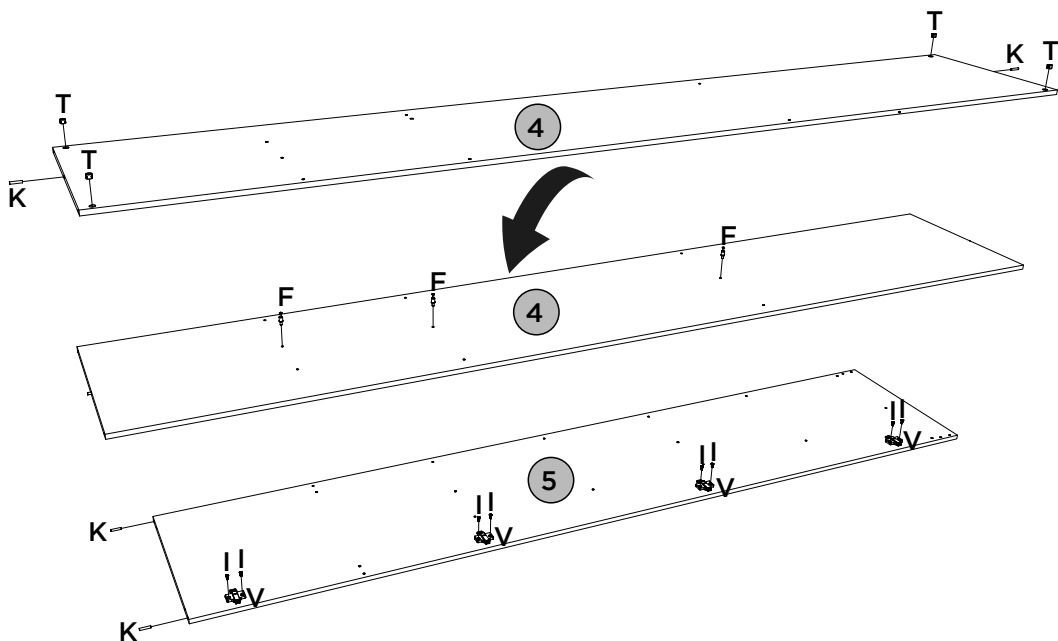
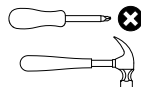

FERRAMENTAS NECESSÁRIAS



PEÇAS REQUERIDAS

6	DIVISÃO MENOR	x1
7	PRATELEIRA MENOR	x3
8	PRATELEIRA DA DIVISÃO	x1
9	DIVISÃO ESQUERDA	x1

ACESSÓRIOS REQUERIDOS

I		05
J		04
K		24
R		02
S		05



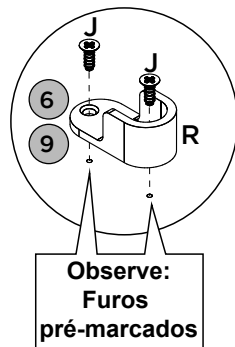
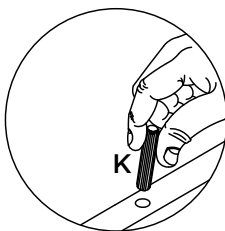
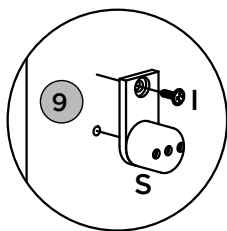
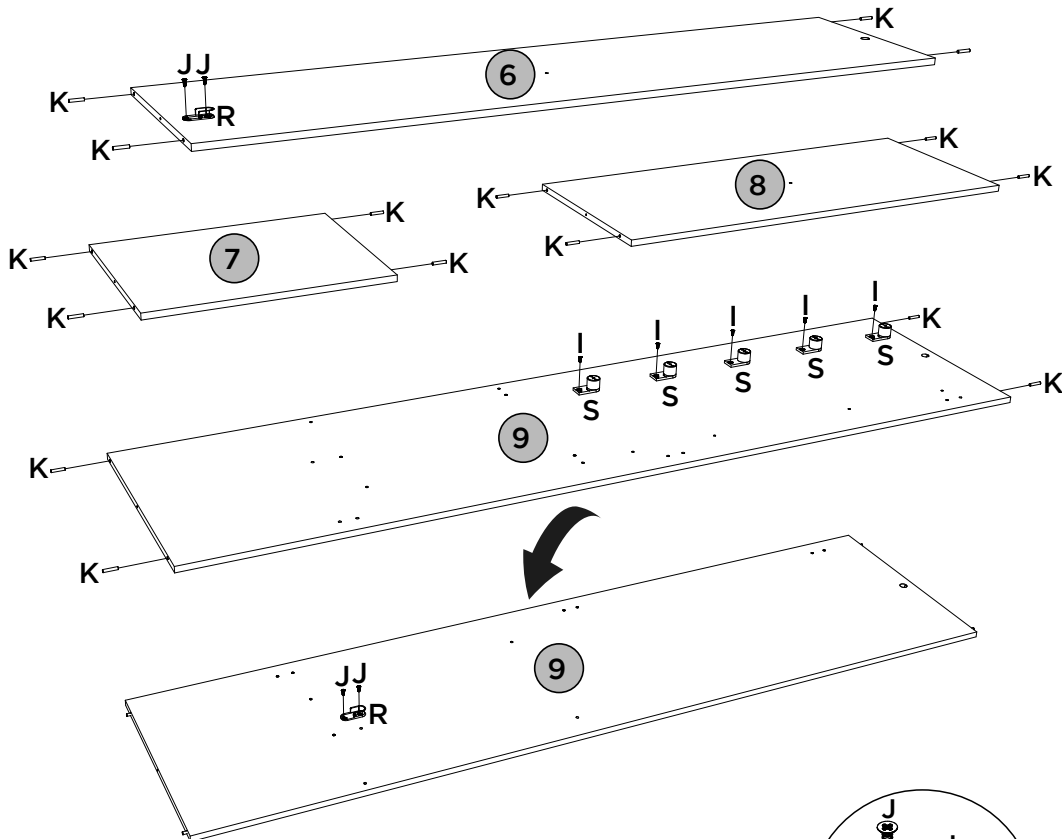
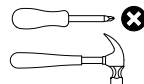

FERRAMENTAS NECESSÁRIAS



PEÇAS REQUERIDAS

10	DIVISÃO DIREITA	x1
11	TAMPO DAS GAVETAS	x1
12	DIVISÃO DA COLMÉIA	x1

ACESSÓRIOS REQUERIDOS

I		05
J		04
K		12
R		02
S		05



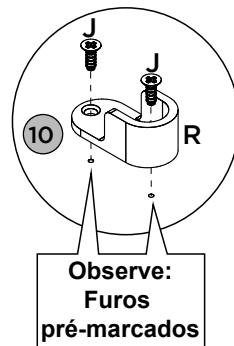
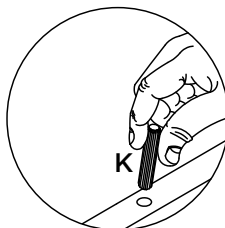
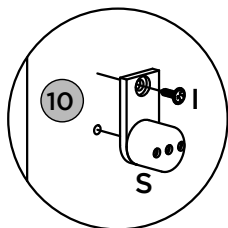
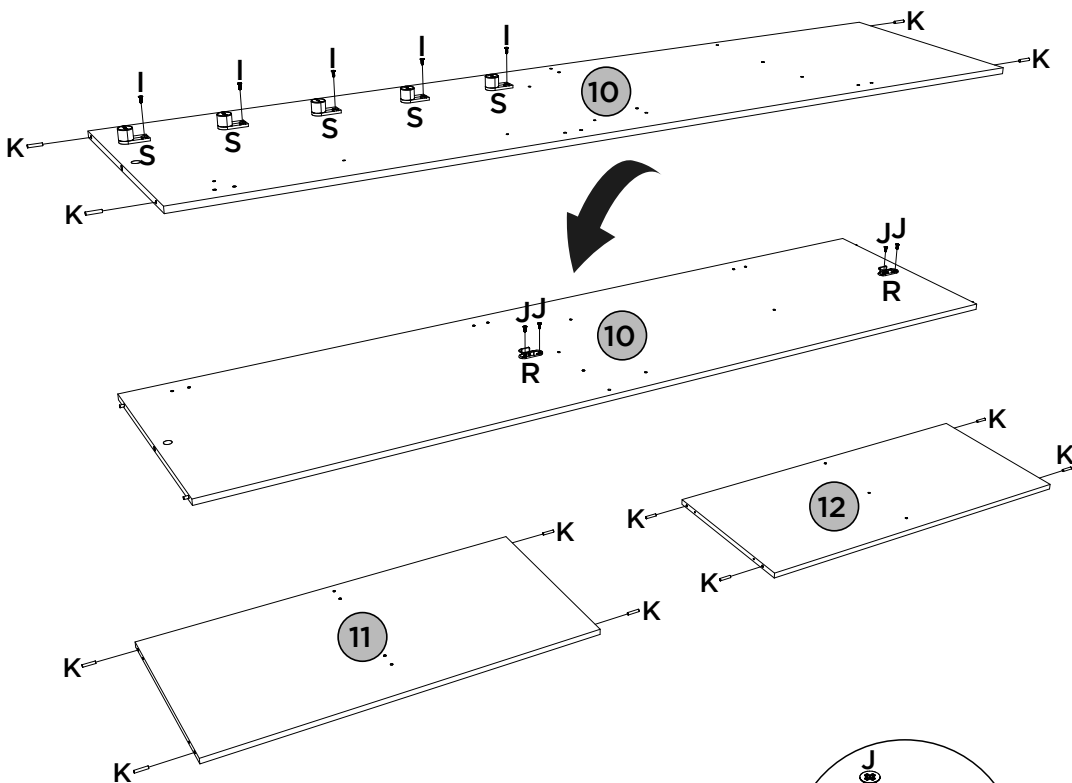
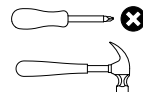

FERRAMENTAS NECESSÁRIAS

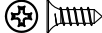

PEÇAS REQUERIDAS

13	PRATELEIRA DA COLMÉIA	x2
14	LATERAL DIREITA	x1
15	PRATELEIRA DO CALCEIRO	x1
16	CHÃO DO MALEIRO	x1

ACESSÓRIOS REQUERIDOS

I		08
J		04
K		18
R		02
V		04

FERRAMENTAS NECESSÁRIAS

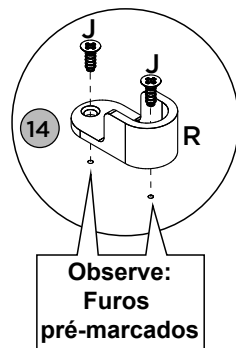
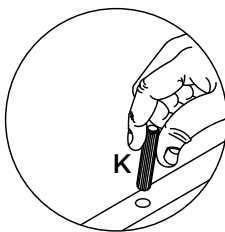
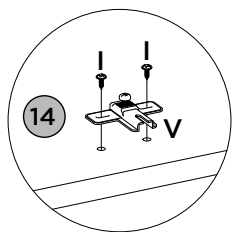
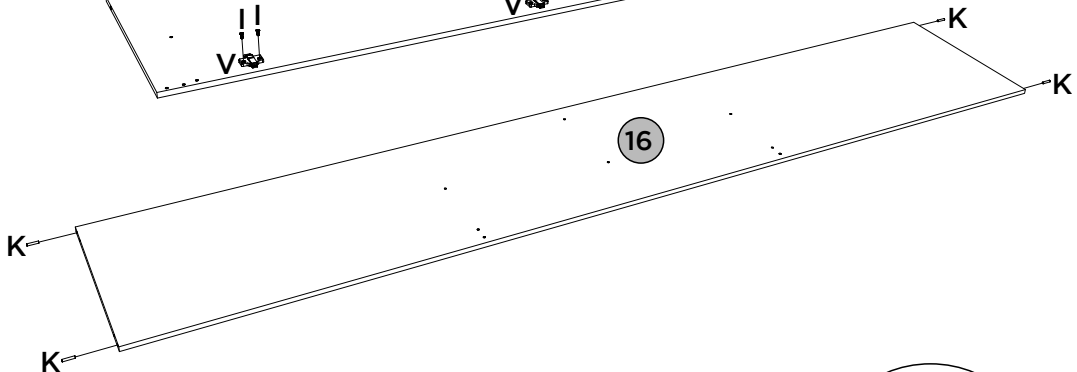
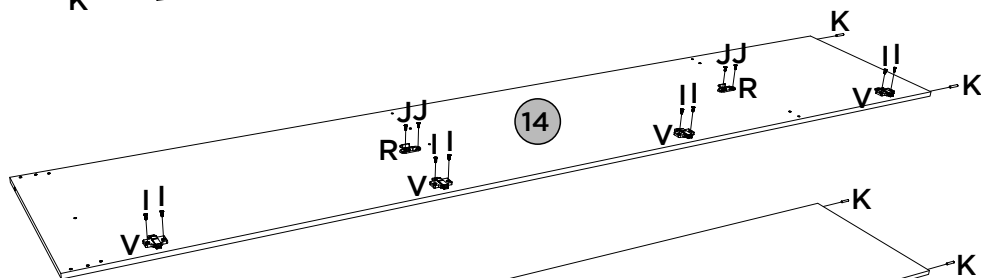
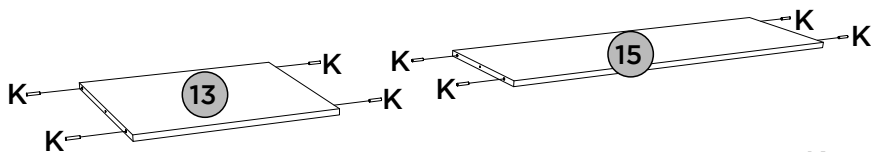
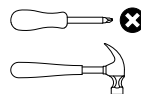



**Observe:
Furos
pré-marcados**

PEÇAS REQUERIDAS

1	RODAPÉ FRONTAL	x1
2	TRAVESSA DO RODAPÉ	x2
3	RODAPÉ TRASEIRO	x1

ACESSÓRIOS REQUERIDOS



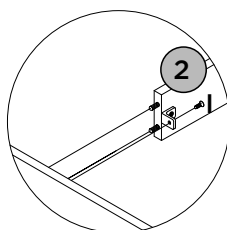
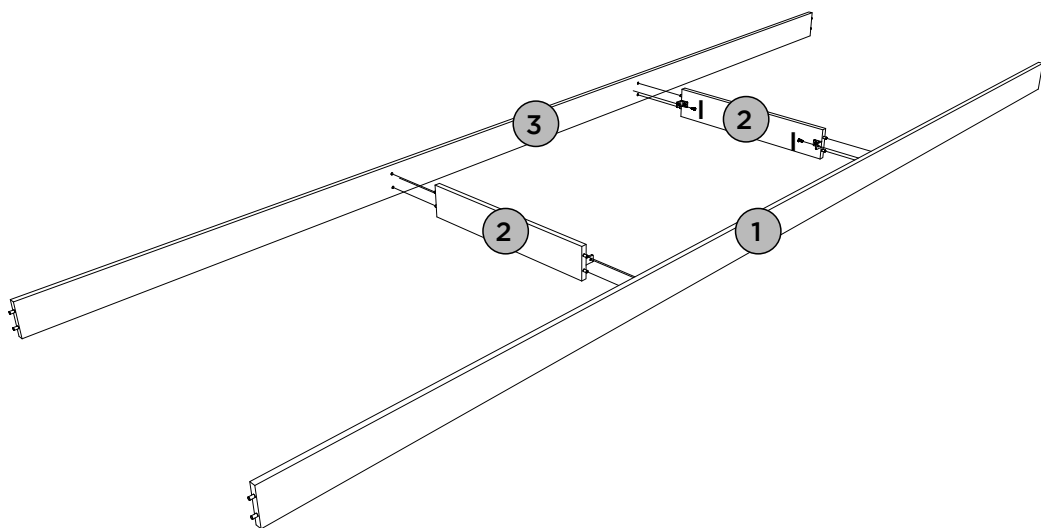
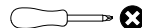



1			04
---	--	--	----

FERRAMENTAS NECESSÁRIAS

PEÇAS REQUERIDAS

4	BASE	x1
5	LATERAL ESQUERDA	x1
6	DIVISÃO MENOR	x1
7	PRATELEIRA MENOR	x3
8	PRATELEIRA DA DIVISÃO	x1

ACESSÓRIOS REQUERIDOS

A		02
B		04
I		36
O		01
P		06
X		08

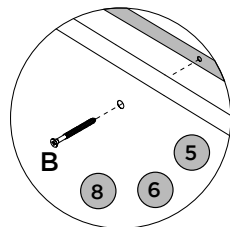
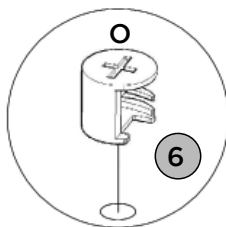
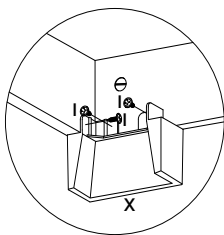
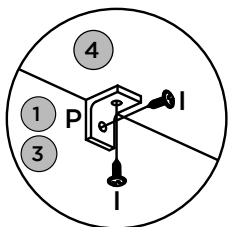
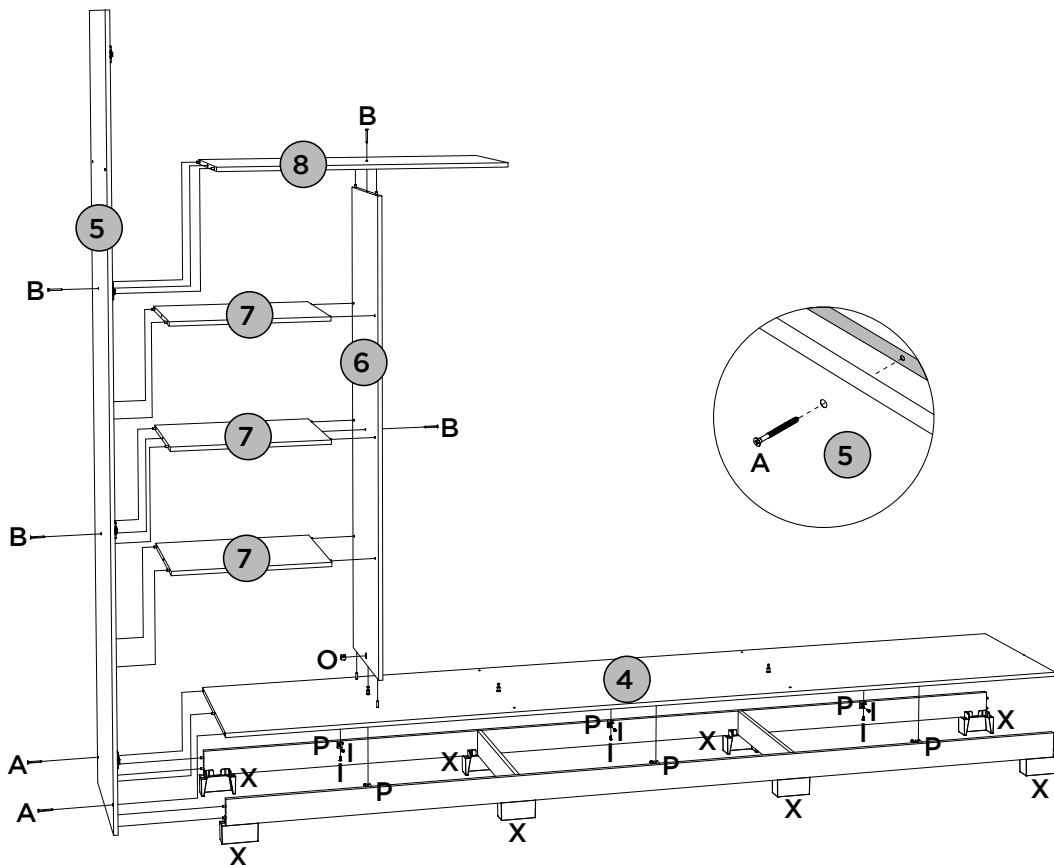
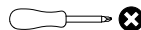
FERRAMENTAS NECESSÁRIAS

PEÇAS REQUERIDAS

9	DIVISÃO ESQUERDA	x1
10	DIVISÃO DIREITA	x1
11	TAMPO DAS GAVETAS	x1
12	DIVISÃO DA COLMÉIA	x1
13	PRATELEIRA DA COLMÉIA	x2



ACESSÓRIOS REQUERIDOS

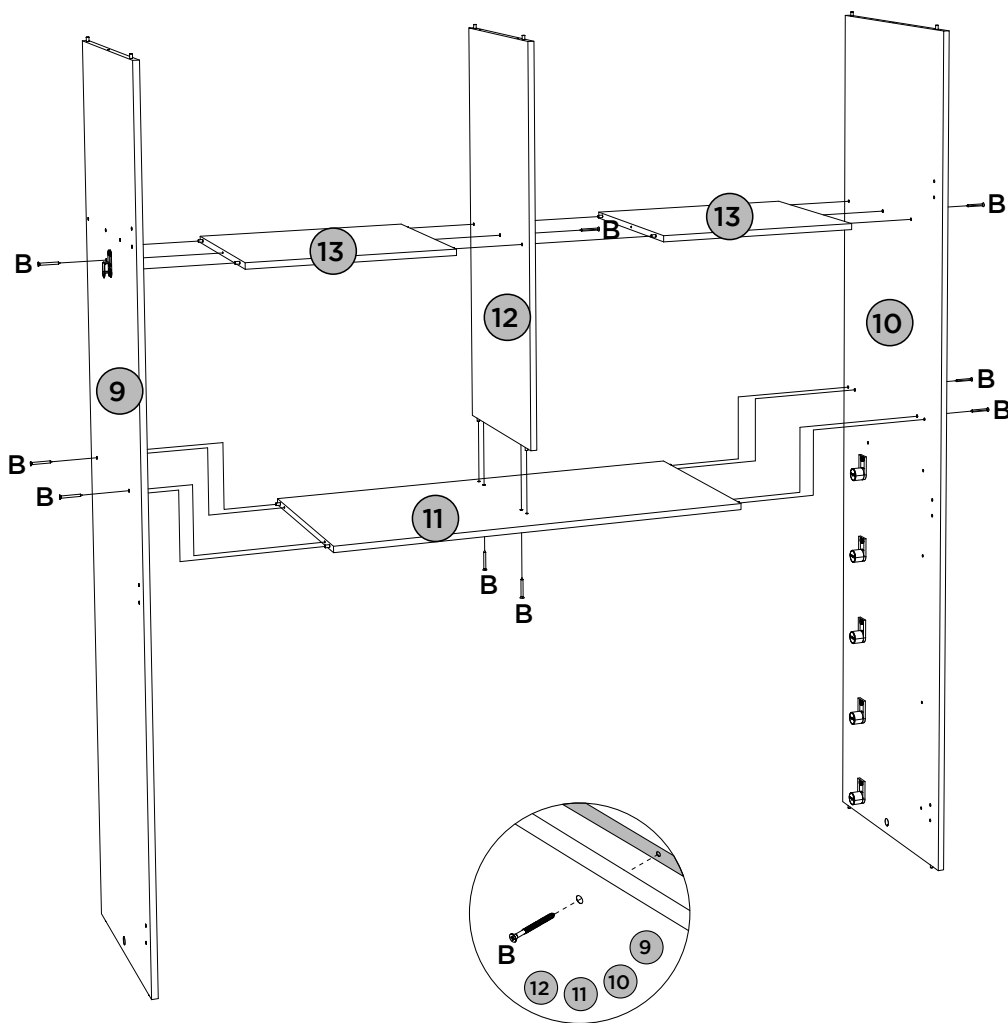
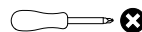

FERRAMENTAS NECESSÁRIAS



ACESSÓRIOS REQUERIDOS

B			01
O			02



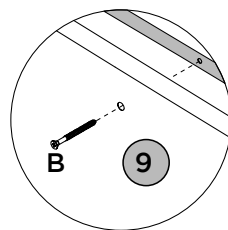
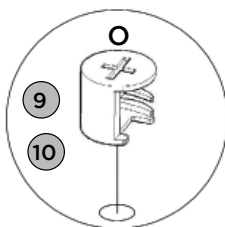
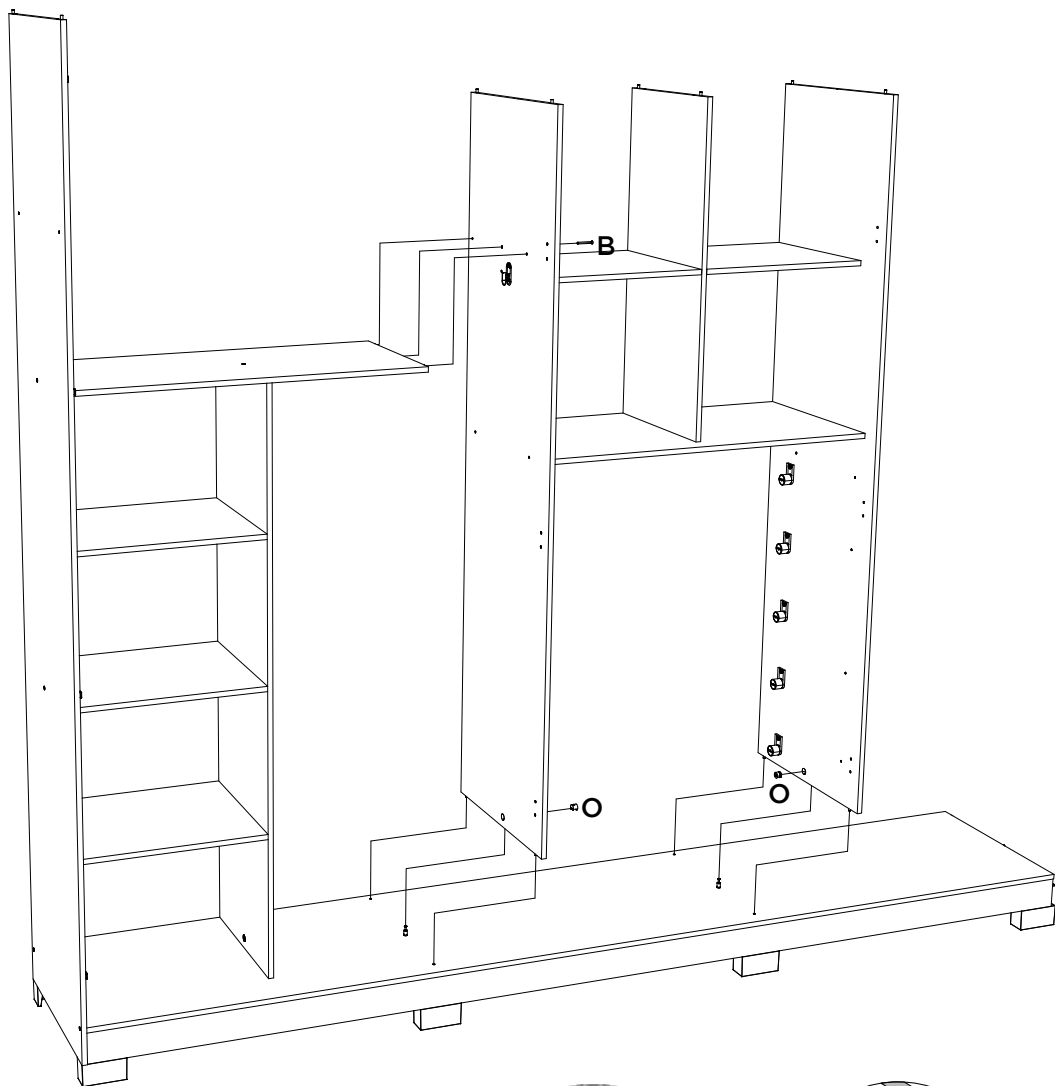
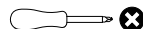



FERRAMENTAS NECESSÁRIAS



PEÇAS REQUERIDAS

14	LATERAL DIREITA	x1
15	PRATELEIRA DO CALCEIRO	x1
16	CHÃO DO MALEIRO	x1
17	RIPA DO MALEIRO	x2
18	TAMPO	x1
19	RIPA LATERAL	x2

ACESSÓRIOS REQUERIDOS

A			02
B			18
C			08



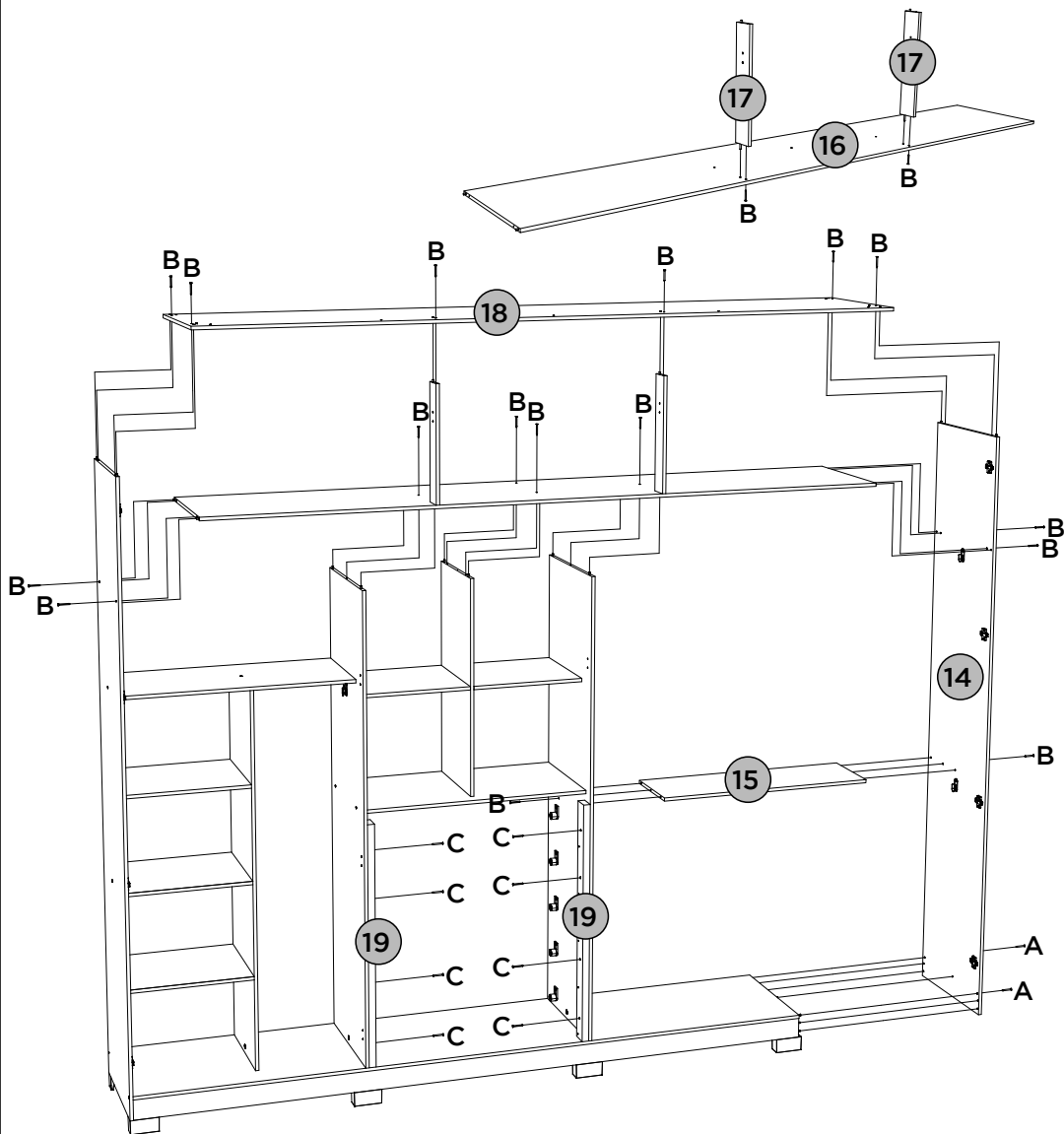
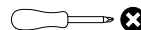



FERRAMENTAS NECESSÁRIAS



PEÇAS REQUERIDAS

20	MOLDURA FRONTAL	x1
21	MOLDURA LATERAL	x2

ACESSÓRIOS REQUERIDOS

D		16
G		09
J		20
U		16
V		16
Y		05

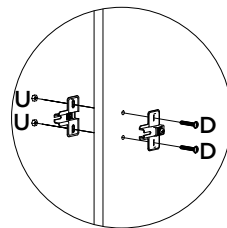
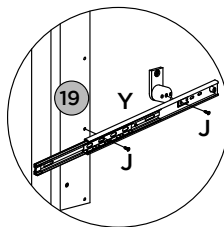
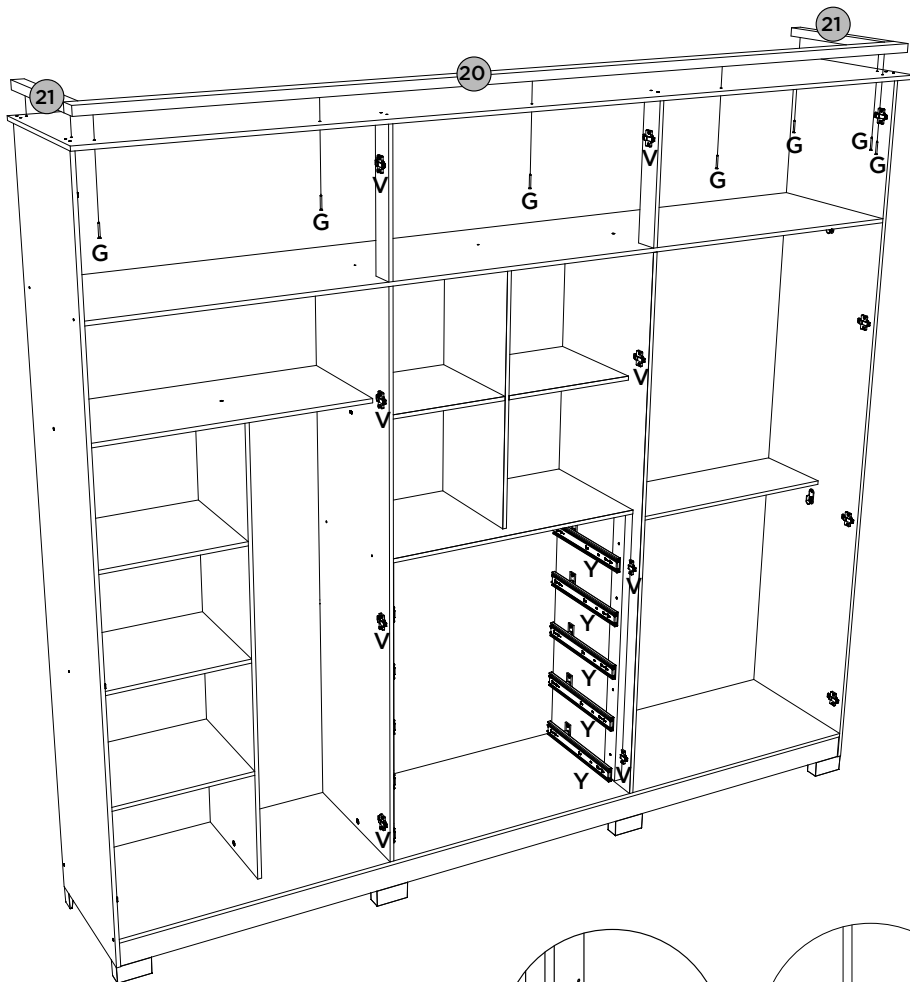
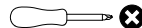
FERRAMENTAS NECESSÁRIAS





PASSO 12

ITM/D303-

PEÇAS REQUERIDAS

22	MOLDURA FRONTAL MAIOR	x1
23	MOLDURA LATERAL MAIOR	x2
24	FUNDO SUPERIOR	x1
25	FUNDO	x6

ACESSÓRIOS REQUERIDOS

G		09
M		154
N		46
AC		03



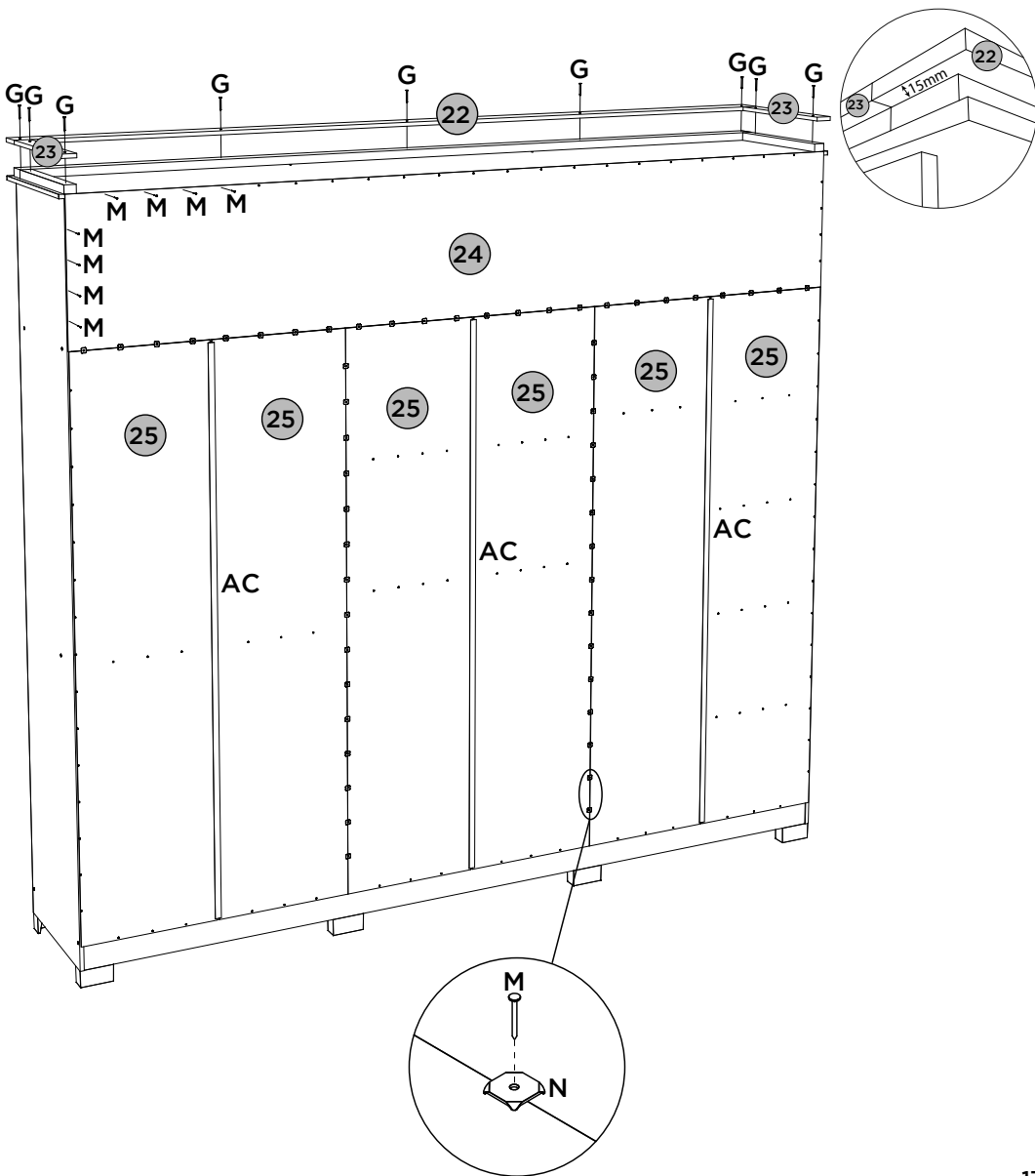
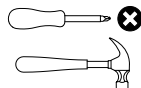

FERRAMENTAS NECESSÁRIAS



PEÇAS REQUERIDAS

26	PORTA	x6
----	-------	----

ACESSÓRIOS REQUERIDOS

E		18
I		48
W		24
Z		06

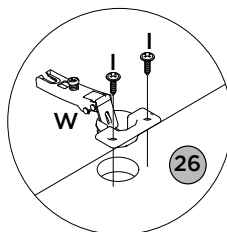
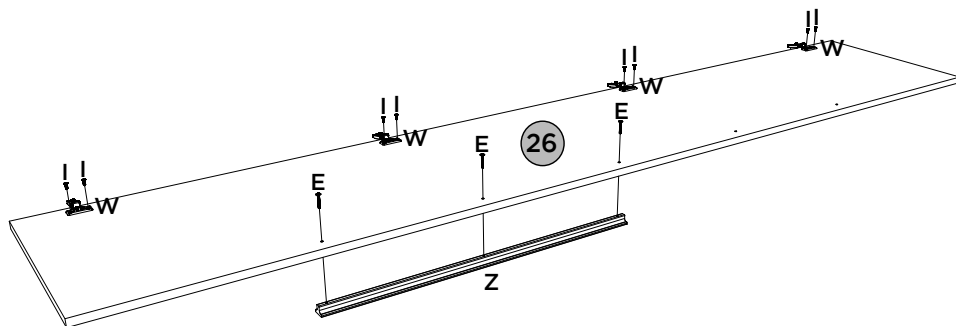
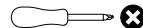

FERRAMENTAS NECESSÁRIAS



PEÇAS REQUERIDAS

26	PORTA	x6
----	-------	----

ACESSÓRIOS REQUERIDOS

AA		01
AB		02

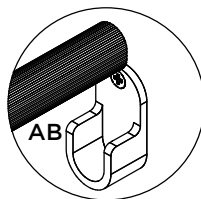
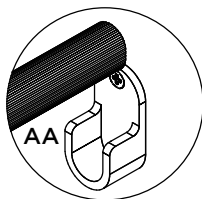
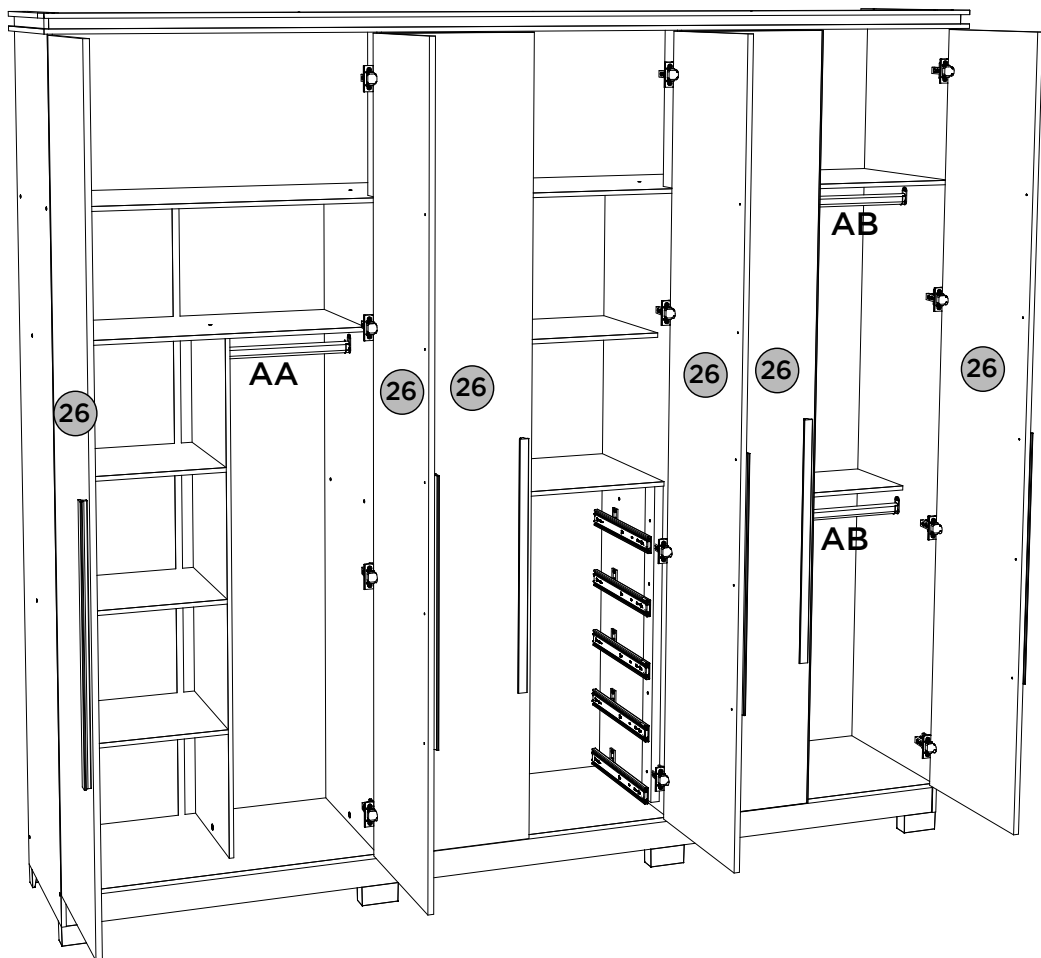





PASSO 15

ITM/D303-

PEÇAS REQUERIDAS

28	LADO DE GAVETA	x10
----	----------------	-----

ACESSÓRIOS REQUERIDOS

J		10
K		40
P		10
AD		

FERRAMENTAS NECESSÁRIAS

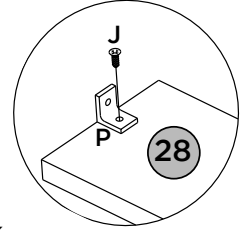
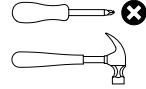

Cantoneira próximo da borda do lado de gaveta (28)

Soporte en ángulo cerca del borde del lado del cajón (28)

Angle bracket near edge of drawer side (28)

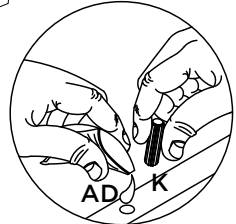
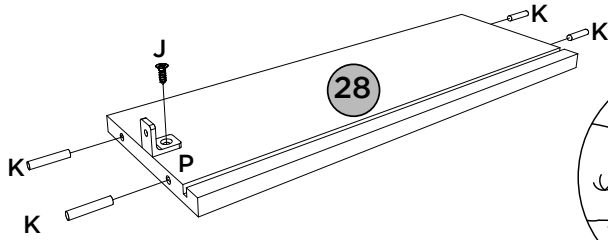

PASSO 16

PEÇAS REQUERIDAS

28	LADO DE GAVETA	x10
30	RIPA DE TRÁS	x5

ACESSÓRIOS REQUERIDOS

AD		
----	---	--

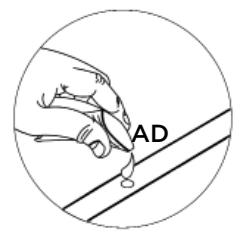
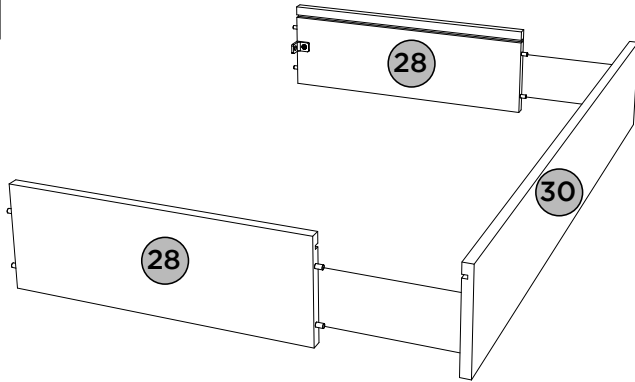

5x
1º



PEÇAS REQUERIDAS







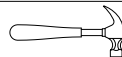
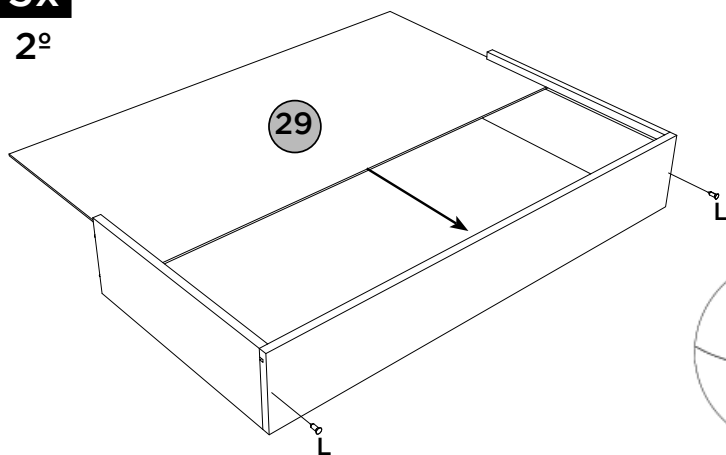
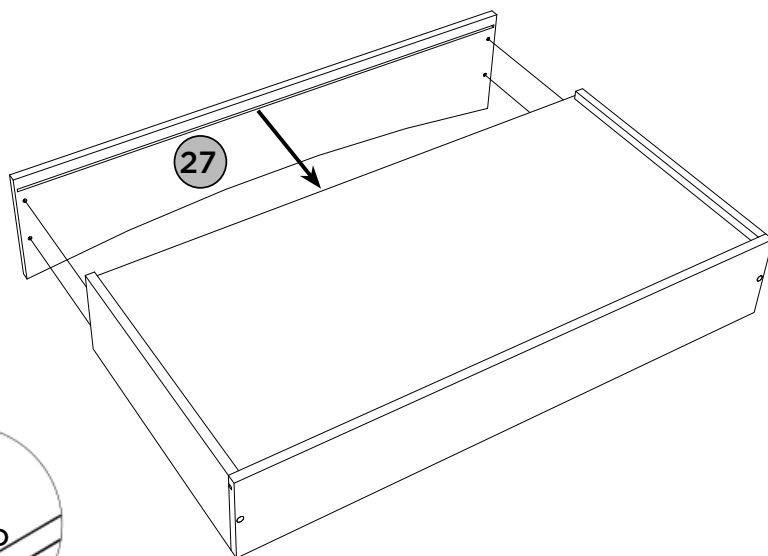

27	FRENTE DE GAVETA	x5
29	FUNDO DE GAVETA RECORTADO	x5

ACESSÓRIOS REQUERIDOS

L		10
AD		

FERRAMENTAS NECESSARIAS

5x
2º

5x
3º

ACESSÓRIOS REQUERIDOS

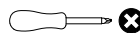
J			40
H			10
Q			10
Y			05

FERRAMENTAS NECESSÁRIAS



5x
4º

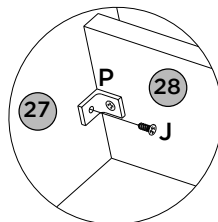
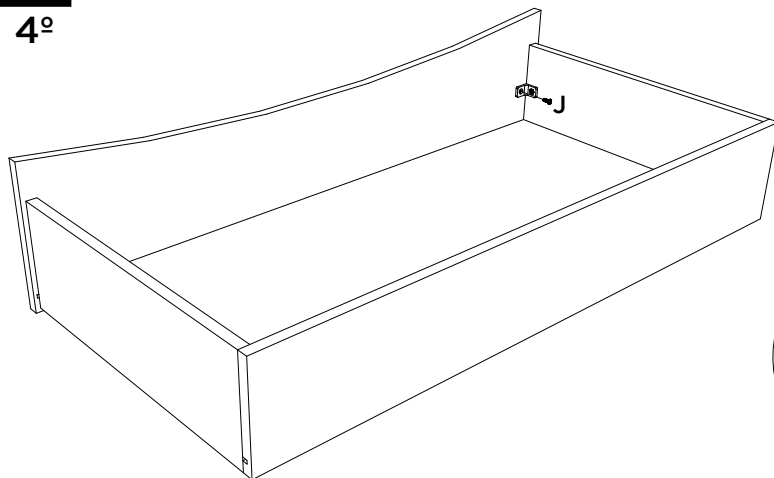

5x
5º

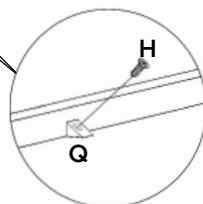
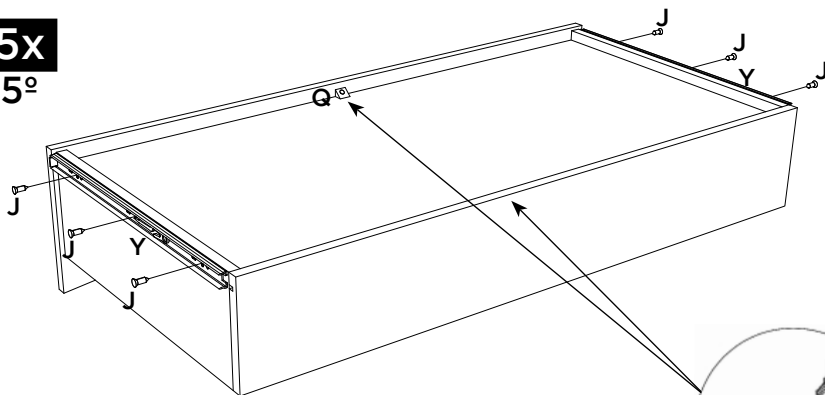

Produto Concluído
Producto terminado
Finished Product

