

Nº	Cód.	Peças	Piezas	Parts	Medida / Size	Qtd.	Vol.
01	07764	Tampo externo	Cubierta externa	External top	1724x345x15	01	01
02	07669	Lateral externa esquerda	Lado exterior izquierdo	Left outer side	343x350x15	01	01
03	07670	Lateral externa direita	Lado exterior derecho	Right outer side	343x350x15	01	01
04	07765	Base externa	Base externa	External base	1724x345x15	01	01
05	07365	Lateral de gaveta	Lateral del cajones	Side panel of the drawer	250x100x15	04	01
06	07430	Contra fundo de gaveta	Trasero del cajones	Rear panel of the drawer	751x100x15	02	01
07	07367	Divisão do nicho	División del nicho	Niche divider	290x125x25	01	01
08	07766	Regua inferior do nicho	Regla inferior del nicho	Niche bottom ruler	1605x28x25	02	01
09	07767	Base interna	Base interna	Internal base	1682x323x20	01	01
10	07768	Regua do tampo	Regla del cubierta	Top ruler	1682x60x20	01	01
11	07673	Lateral interna	Lado interno	Inner side	323x342x20	02	01
12	07769	Tampo do nicho	Parte superior del nicho	Niche top	1603x290x12	01	01
13	07376	Lateral do nicho	Lateral del nicho	Niche of side	290x125x12	02	01
14	07436	Frente de gaveta	Frente del cajones	Front of drawer	798x150x15	02	01
15	07437	Fundo de gaveta	Fondo del cajones	Bottom of the drawer	733x262x2,5	02	01
16	07770	Fundo traseiro furado	Fondo trasero perforado	Bottom rear holed	1715x372x2,5	01	01
17	30018851	Kit vidro	Kit vidrio	Glass kit	210x165x8	02	01

Recorte aqui e guarde seu certificado de garantia!

Certificado de garantia

A Gelius Indústria de Móveis confia na qualidade de seus produtos e por isso o garante pelo prazo de 90 dias para defeitos de fabricação em condições normais de uso.

Resultarão nula a garantia e sem efeito a cobertura, se o produto, (incluindo vidros e ou espelhos que o compõe):

- sofrer dano provocado por acidente, agente da natureza.
- uso indevido ou maus tratos como arrastar, subir em cima, colocar produtos com excesso de peso).
- não utilizado para os fins a que se destina.
- conter manchas provocadas por uso de produtos químicos em sua limpeza.
- excesso de umidade ou água.

Ao detectar qualquer defeito em seu móvel, entre em contato com a loja onde foi efetuada a compra. A comprovação de que o móvel a ser consertado ou substituído encontra-se dentro do prazo de garantia é de total responsabilidade do fabricante e deve ser feita mediante a apresentação desse certificado corretamente preenchido e sem rasuras ou resalvas.

Cuidados com seu móvel Gelius!

- para limpeza do seu móvel, utilize apenas pano macio e seco.
- jamais limpe-o com palha de aço, álcool ou qualquer outro produto químico ou abrasivos, óleos de peroba ou produtos do gênero.
- evite deixá-lo sob raios solares ou chuva.
- ao transportar o seu móvel Gelius, prenda-o firmemente para que não ocorra quedas indesejáveis.

Seguindo corretamente as informações acima, você conservará por muito mais tempo o seu móvel Gelius!

GARANTIA DO CLIENTE:

Cliente: _____

Rua: _____ Nº: _____ Bairro: _____

Cidade: _____ UF: _____ Loja onde comprou: _____

Data da compra: ____/____/____ Nota Fiscal: _____

Data da reclamação na loja: ____/____/____

Defeito constante: _____

Recomendações | Recomendaciones | Recommendations

Atenção
Atención
Attention

Este produto deve ser montado por um profissional.

Este producto debe ser ensamblado por un profesional.

This product must be assembled by a professional.

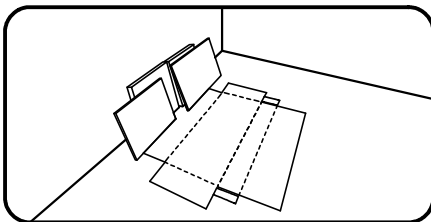

Antes de começar a montagem prepare o ambiente, deixando-o completamente limpo e com bom espaço para iniciar o trabalho. Utilize o papelão da própria embalagem para separar e apoiar as peças retiradas da caixa.

Antes de comenzar el montaje preparar el ambiente, dejándolo completamente limpio y con buen espacio para comenzar el trabajo. Utilice el cartón de la embalaje para separar y apoyar las piezas desmontadas de las cajas.

Prepare the room before starting the assembly, leaving it completely clean and the area in good condition to start the work. Use the cardboard of the packaging to separate and support the parts removed from the boxes.

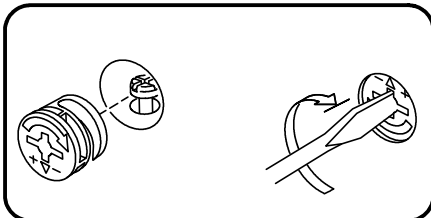

Como usar o acessório Pino e Tambor Minifix (quando utilizado no produto).

Como usar el herraje Pino y Tambor Minifix (cuando se usa en el producto).

How to use the Minifix Set (when used in the product).

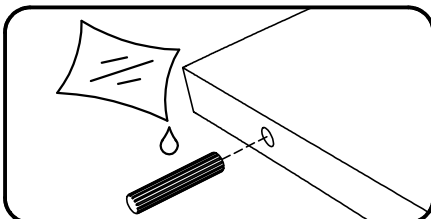

Aplicar cola nas cavilhas de madeira (quando utilizado no produto).

Aplicar pegamento a las clavijas de madera (cuando se usa en el producto).

Apply glues to the wooden dowels (when used in the product).

Ferramentas recomendadas para montagem | Herramientas de montaje recomendadas | Recommended tools

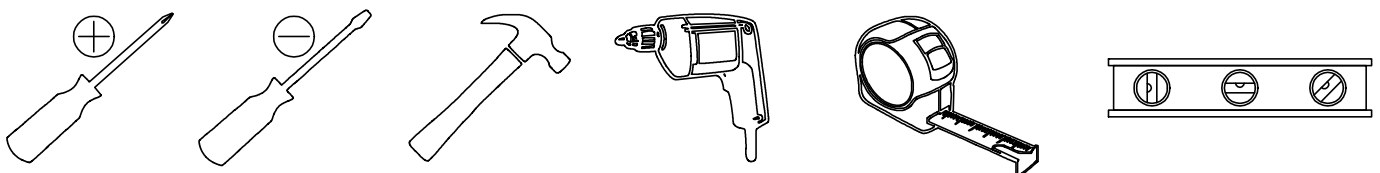

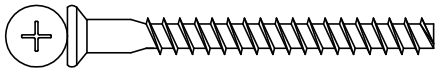
Acessórios e ferragens | Herrajes | Hardware

A) cód. 30010093 010 un.

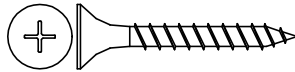

B) cód. 30000716 007 un.



C) cód. 30014538 022 un.

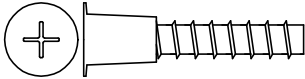

D) cód. 30018169 006 un.

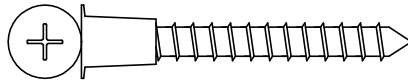

E) cód. 30017779 004 un.

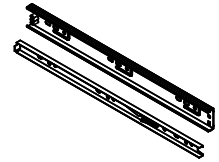

F) cód. 30017790 004 un.

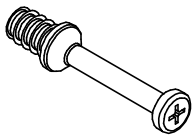

G) cód. 30006753 026 un.



H) cód. 30001073 026 un.



I) cód. 30000783 042 un.

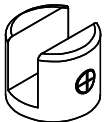

J) cód. 30018560 002 un.



K) cód. * 040 un.



L) cód. * 012 un.

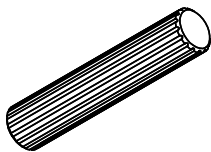

M) cód. 30000770 002 un.

01

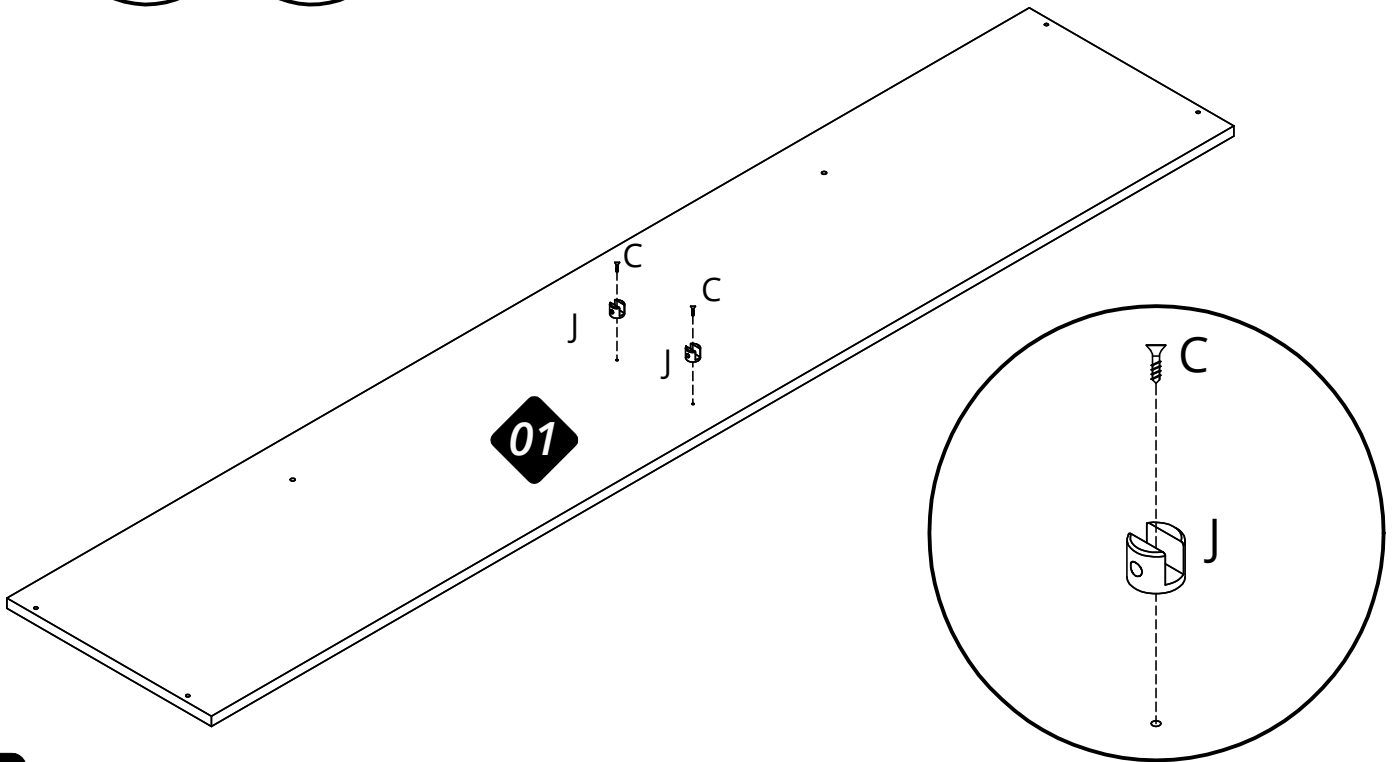
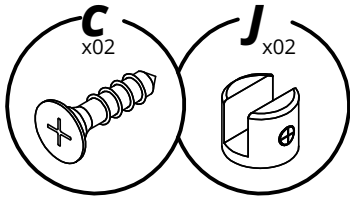

02

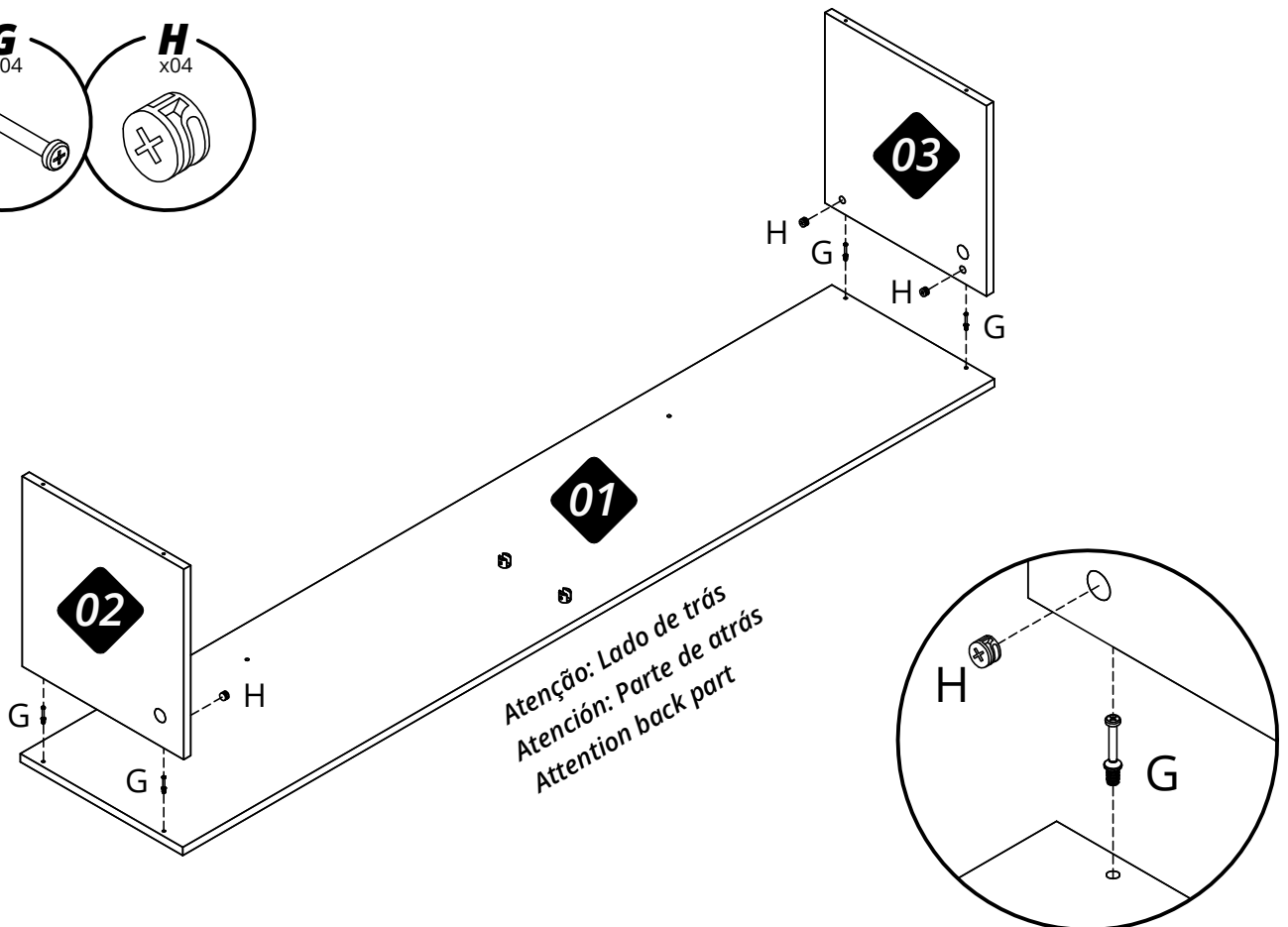
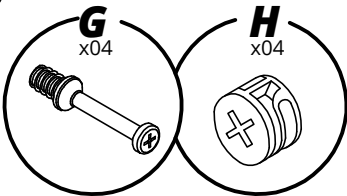

03

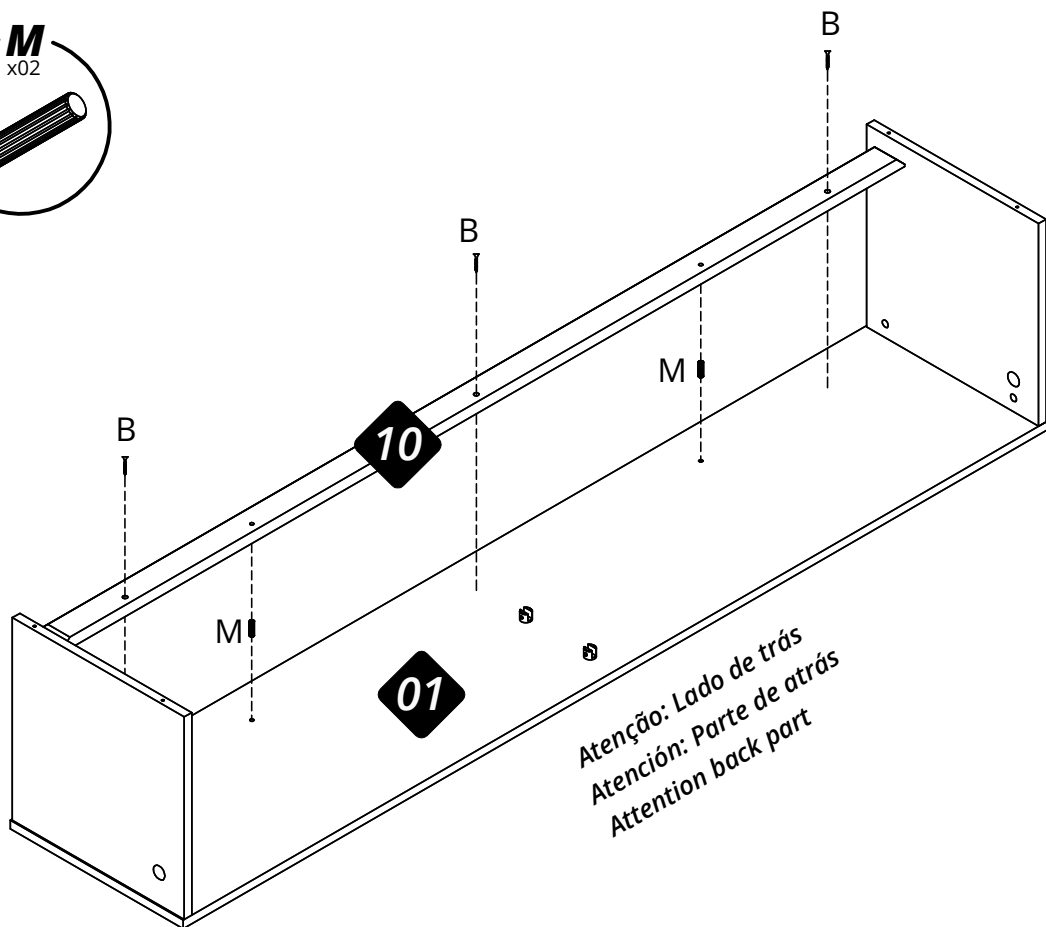
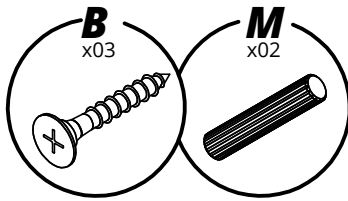

04

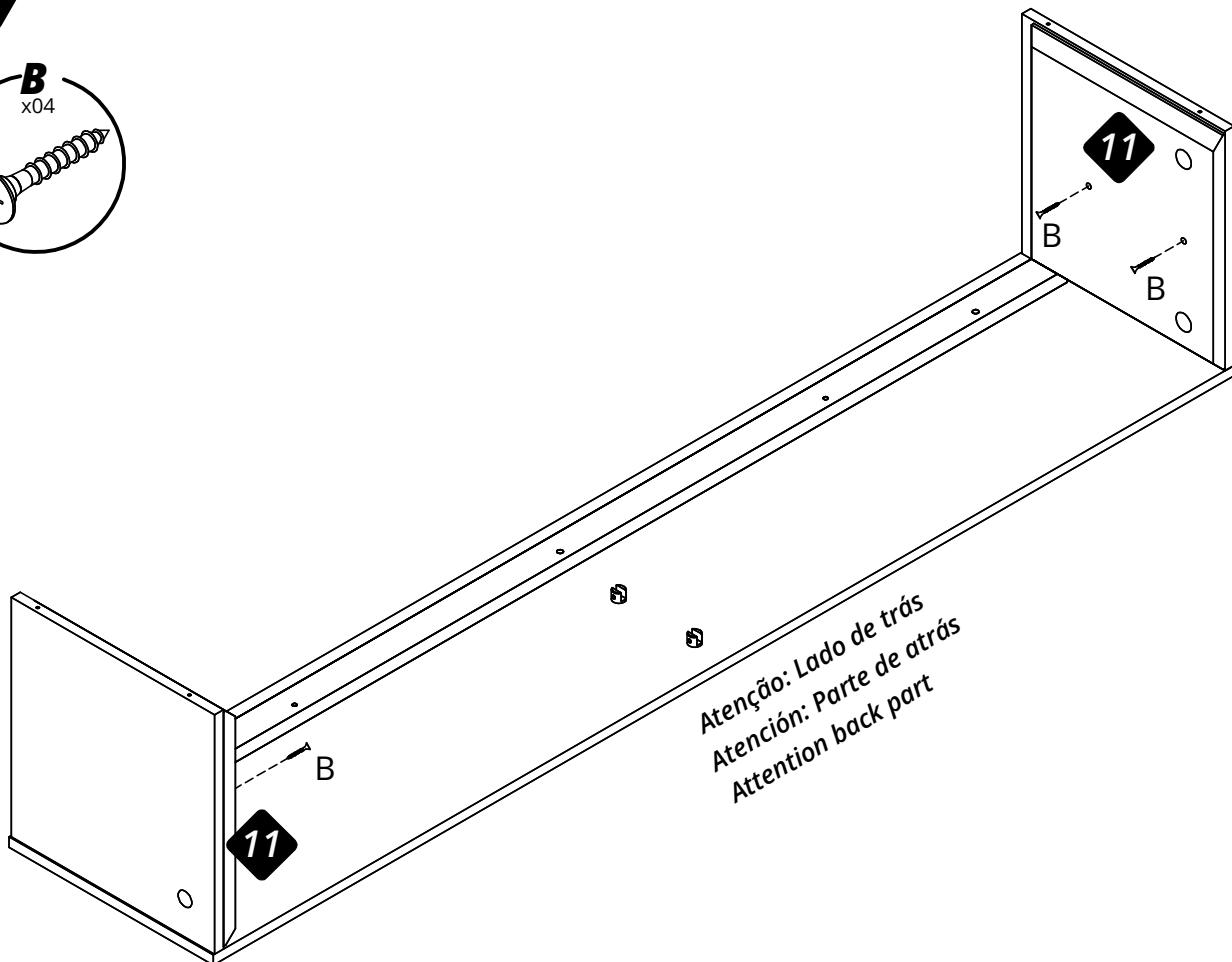
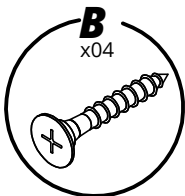

05

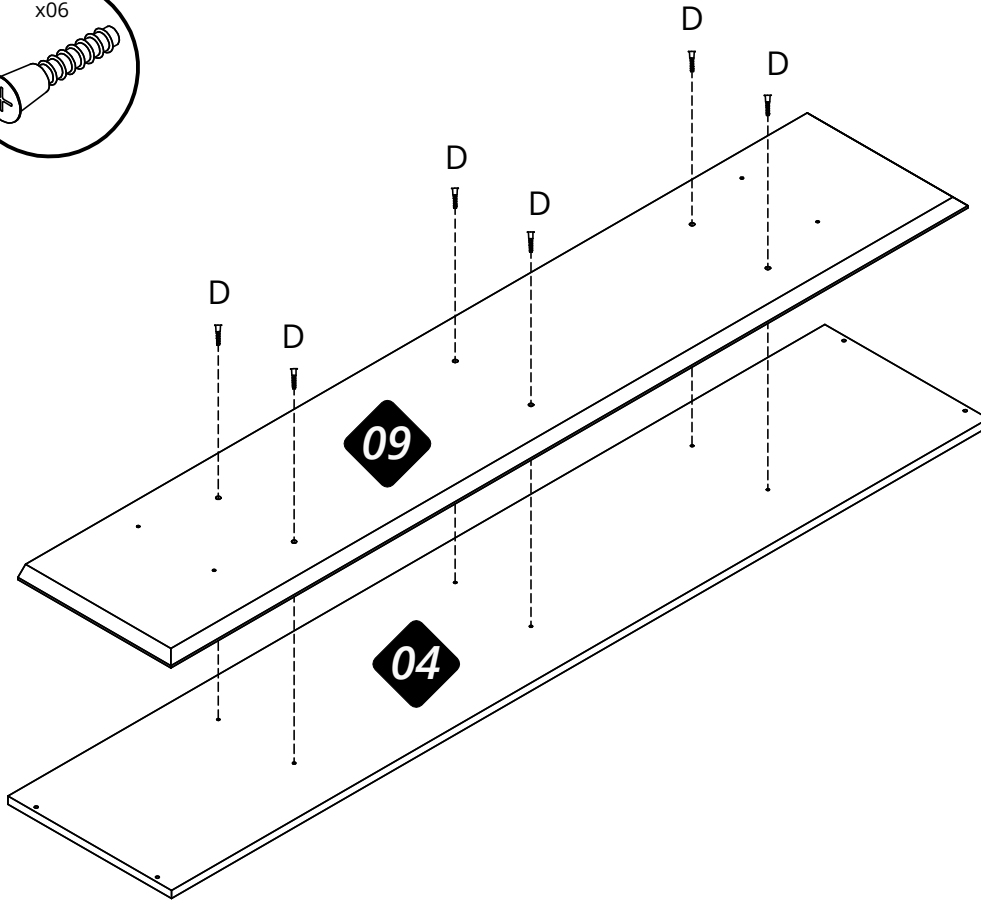
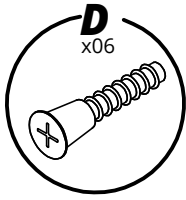

06

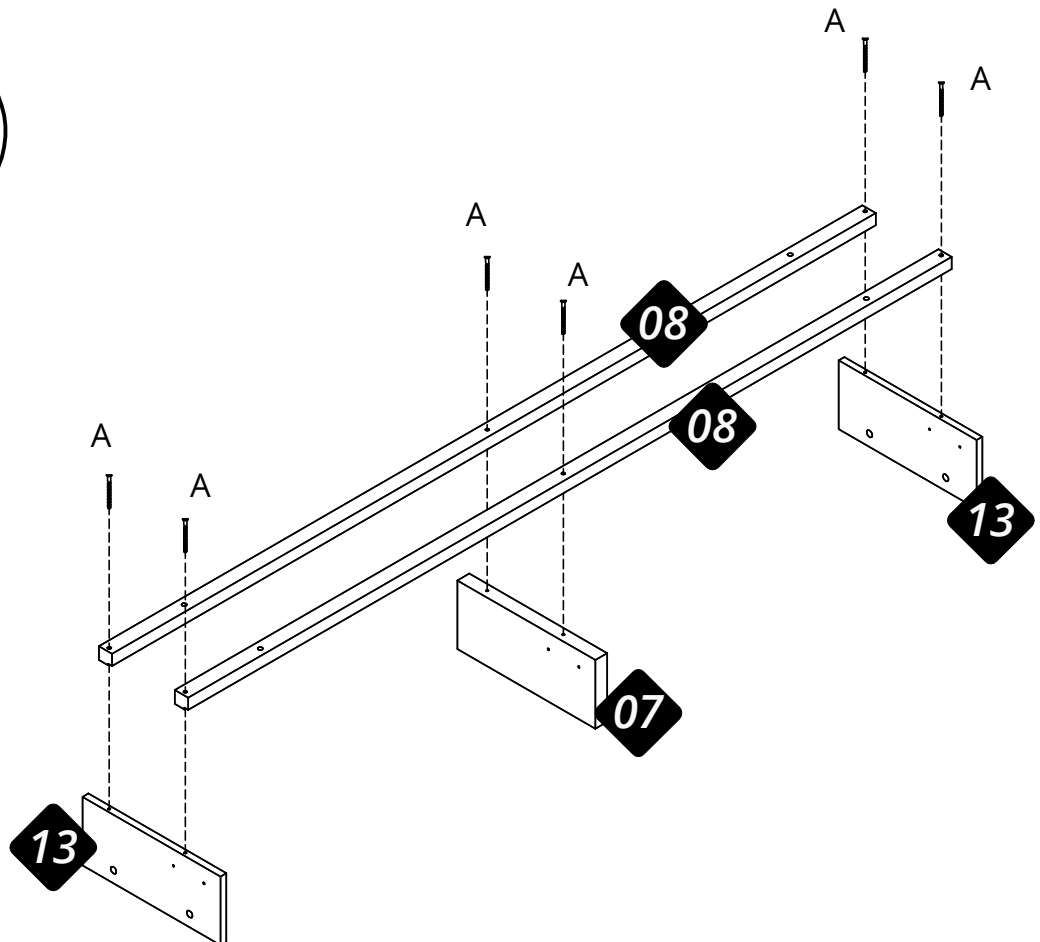
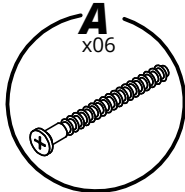

07

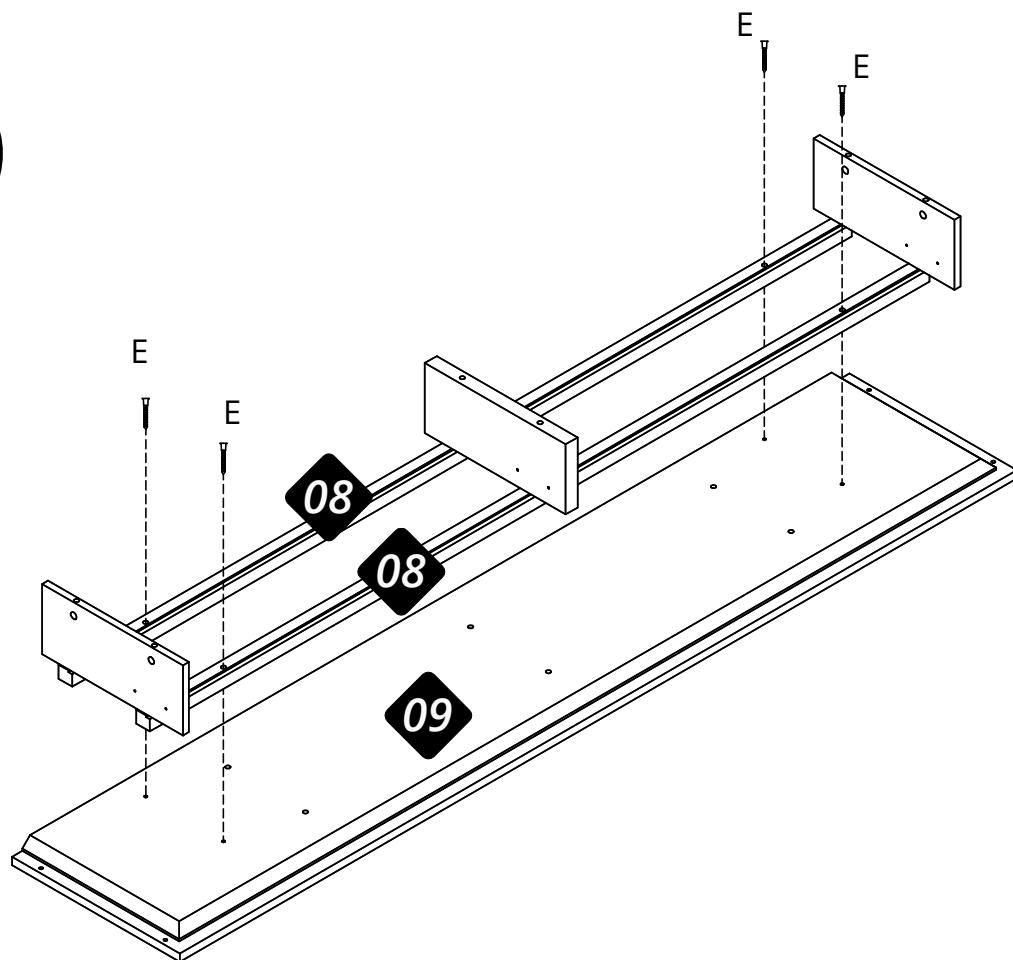
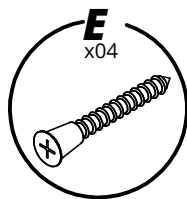

08

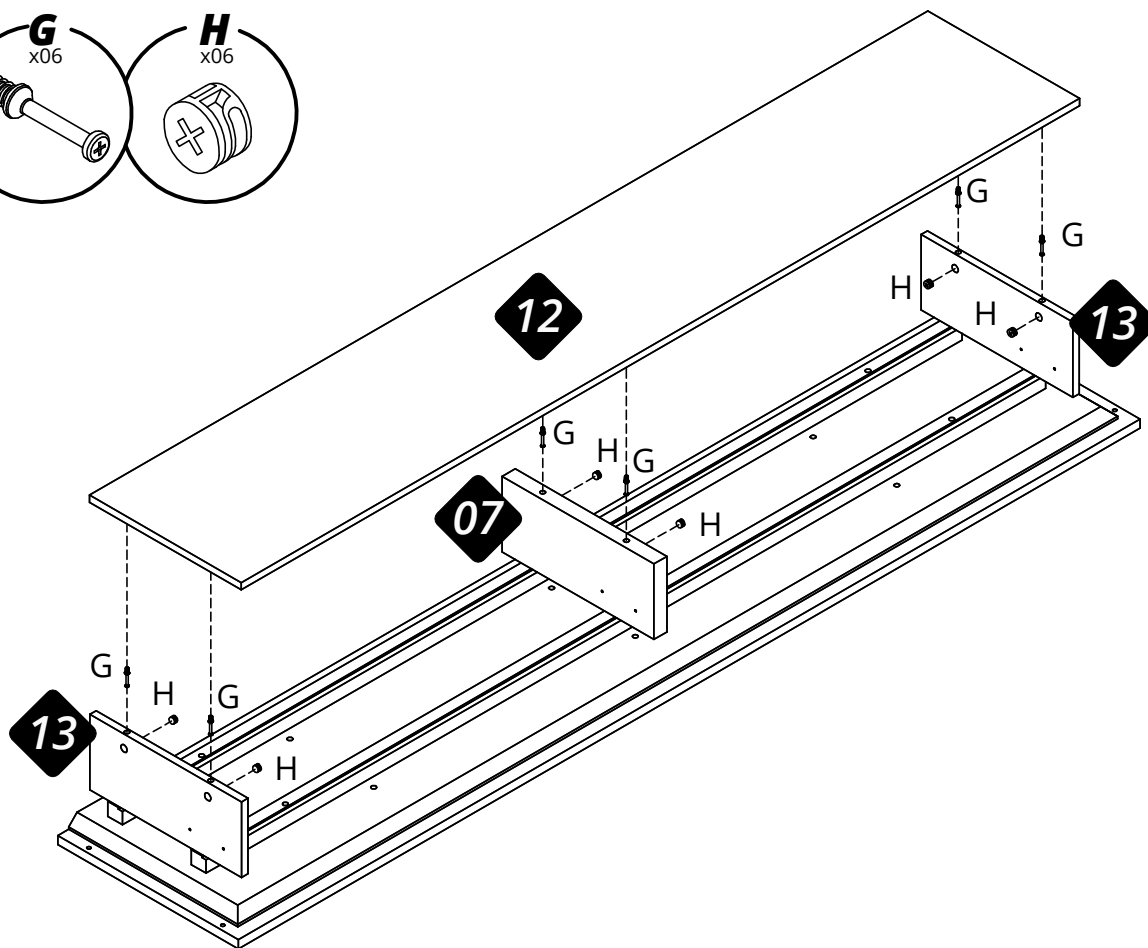
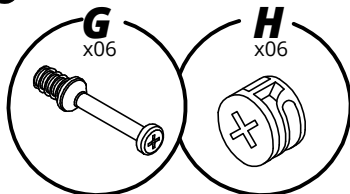

09

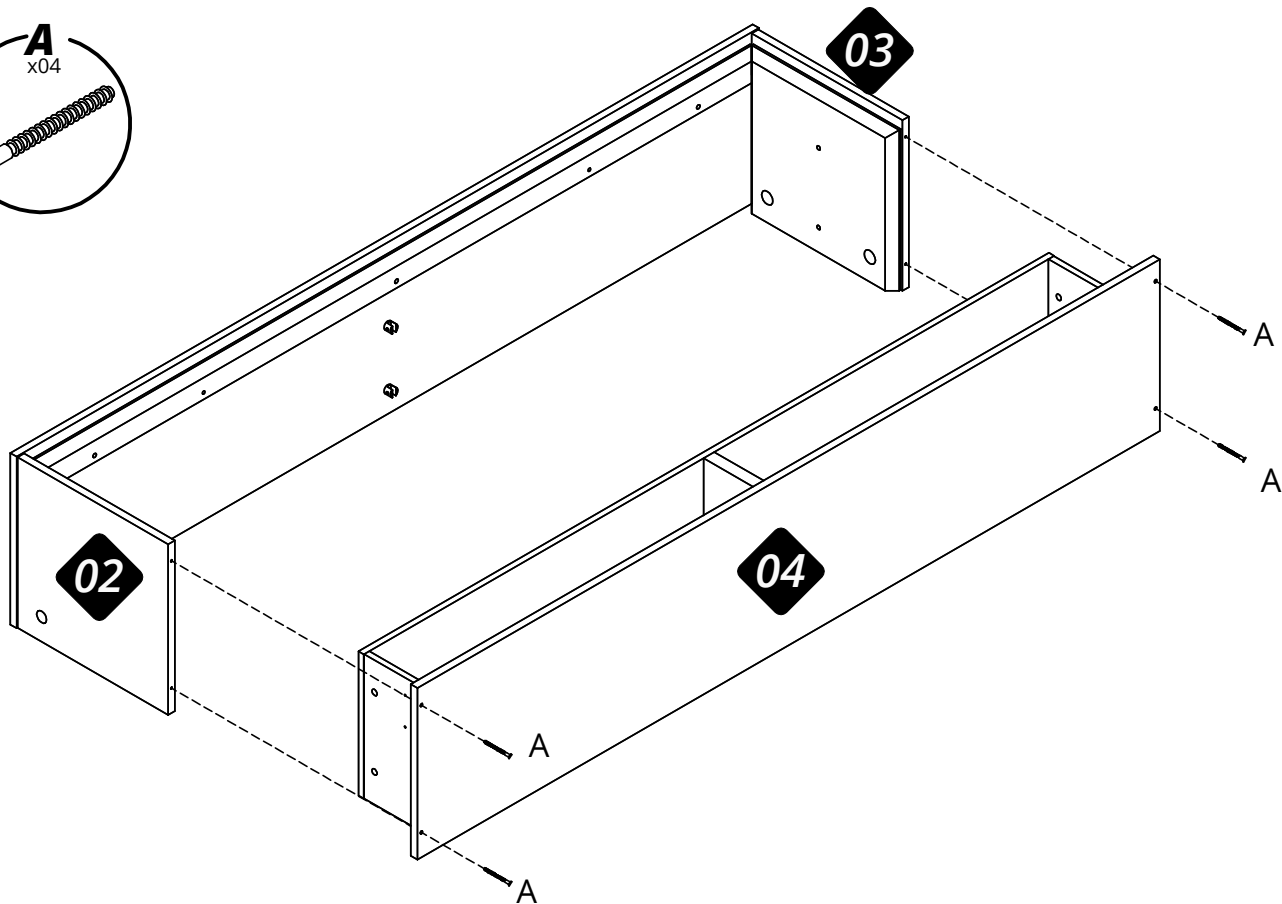
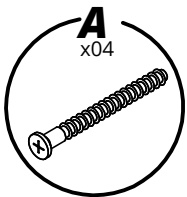

10

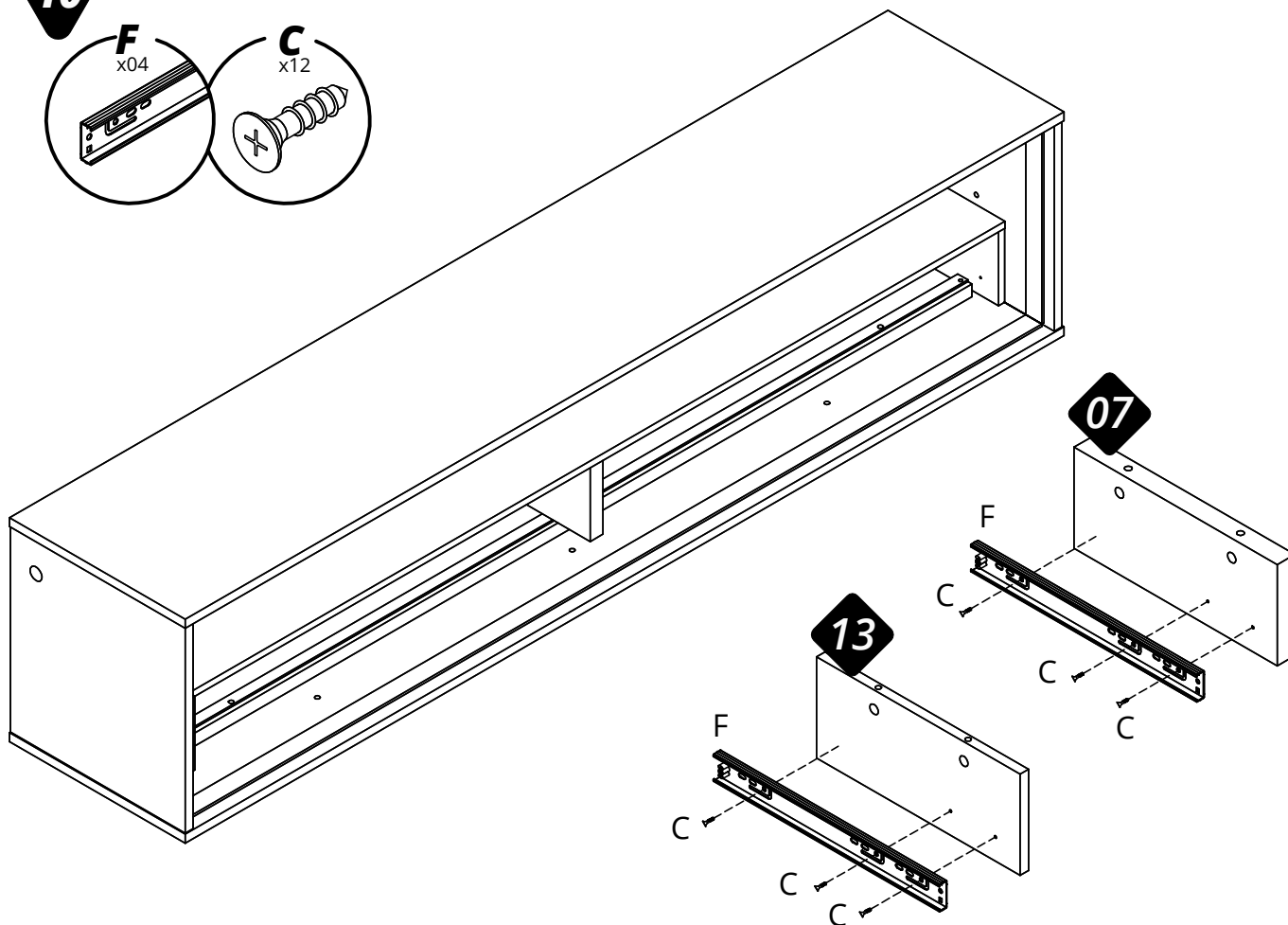
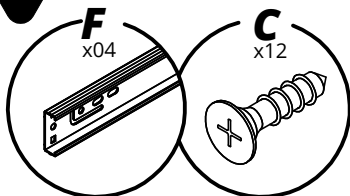

11

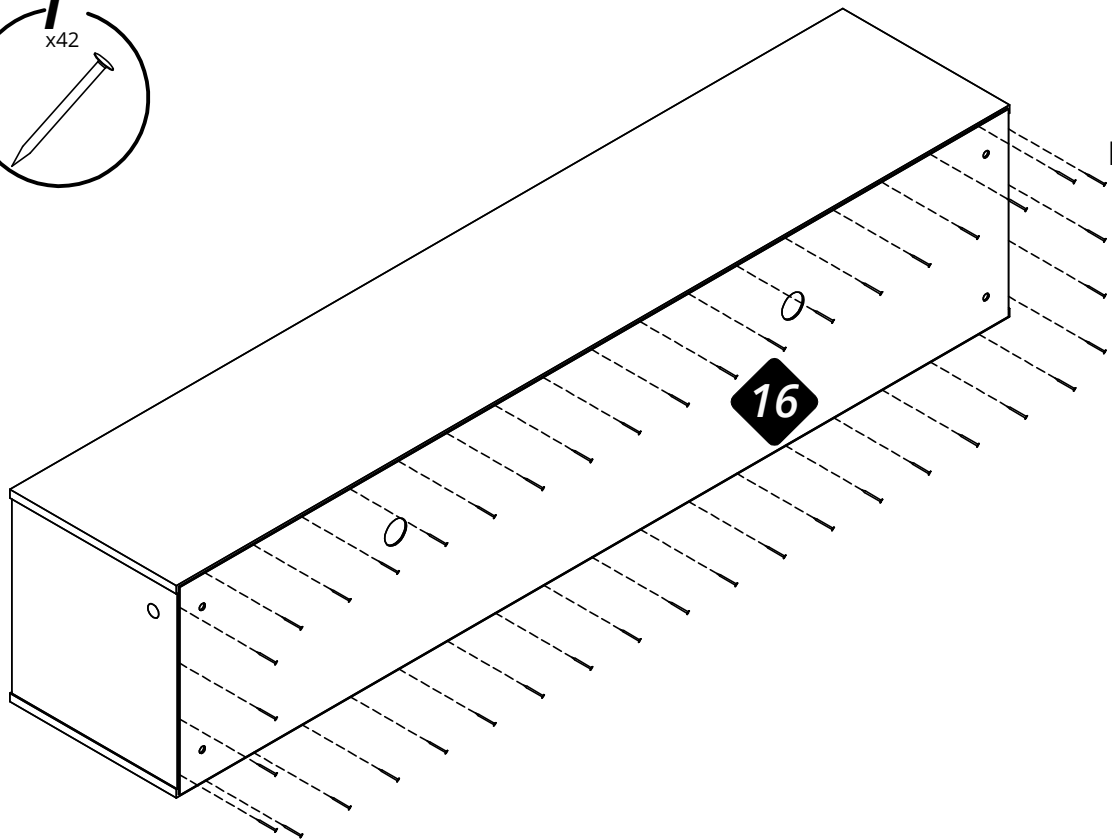
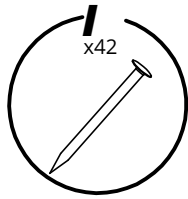

12

KIT LED

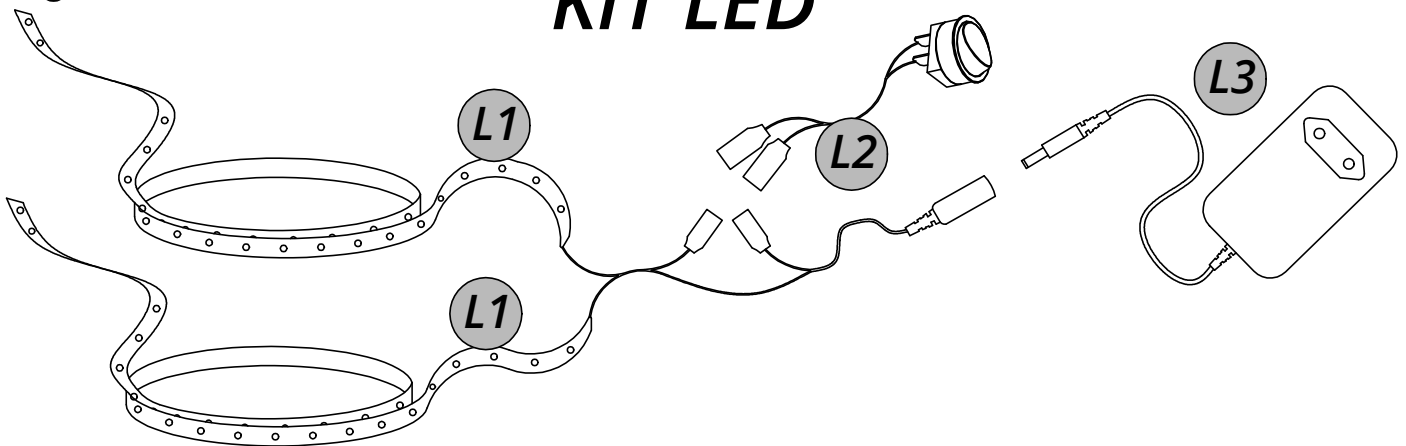

Retire a película protetora da fita dupla face e inicie a colagem da fita de led no rebaixo da peça nº 08, e na parte interna da peça nº 01.

Retire la película protectora de la cinta de doble cara y comience a pegar la tira de Led en el hueco de la pieza nº 08 y en el interior de la pieza nº 01.

Remove the protective film from the double-sided tape and start gluing the Led strip to the recess of part nº 08, and to the inside of part nº 01.

13

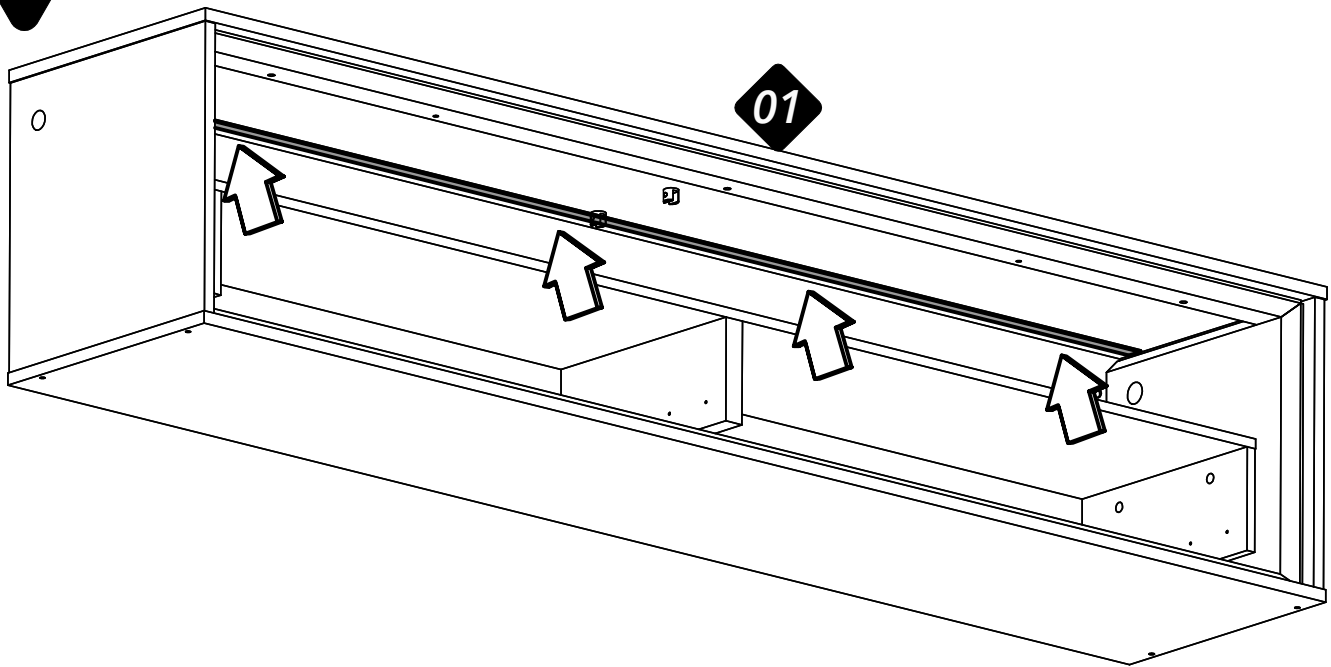

Aplique a fita led na peça n°01 no local indicado pela seta.

Aplique la tira de led a la pieza n°01 en el lugar indicado por la flecha.

Apply the led strip to part n°01 in the place indicated by the arrow.

14

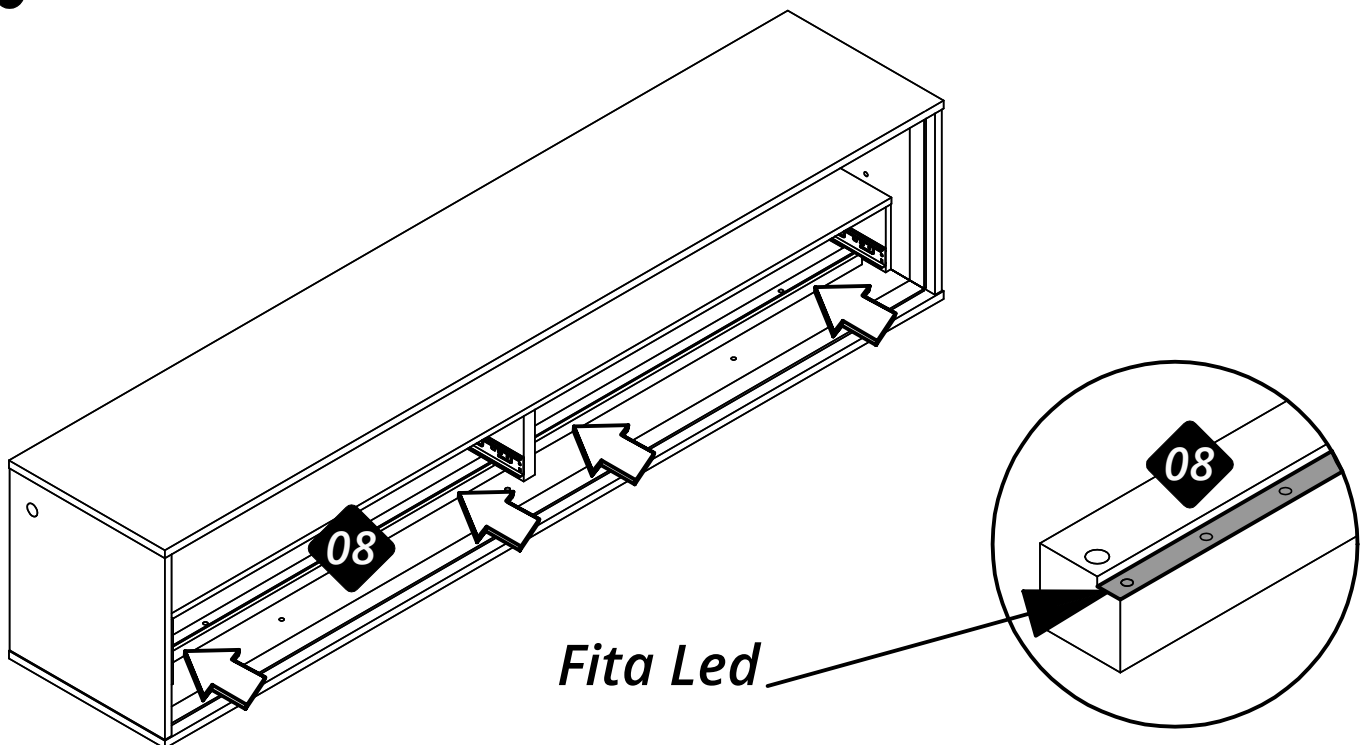

Aplique a fita led na peça n° 08 no local indicado pela seta.

Aplicar la cinta led sobre la pieza n° 08 en el lugar indicado por la flecha.

Apply the led tape on part n° 08 in the place indicated by the arrow.

15

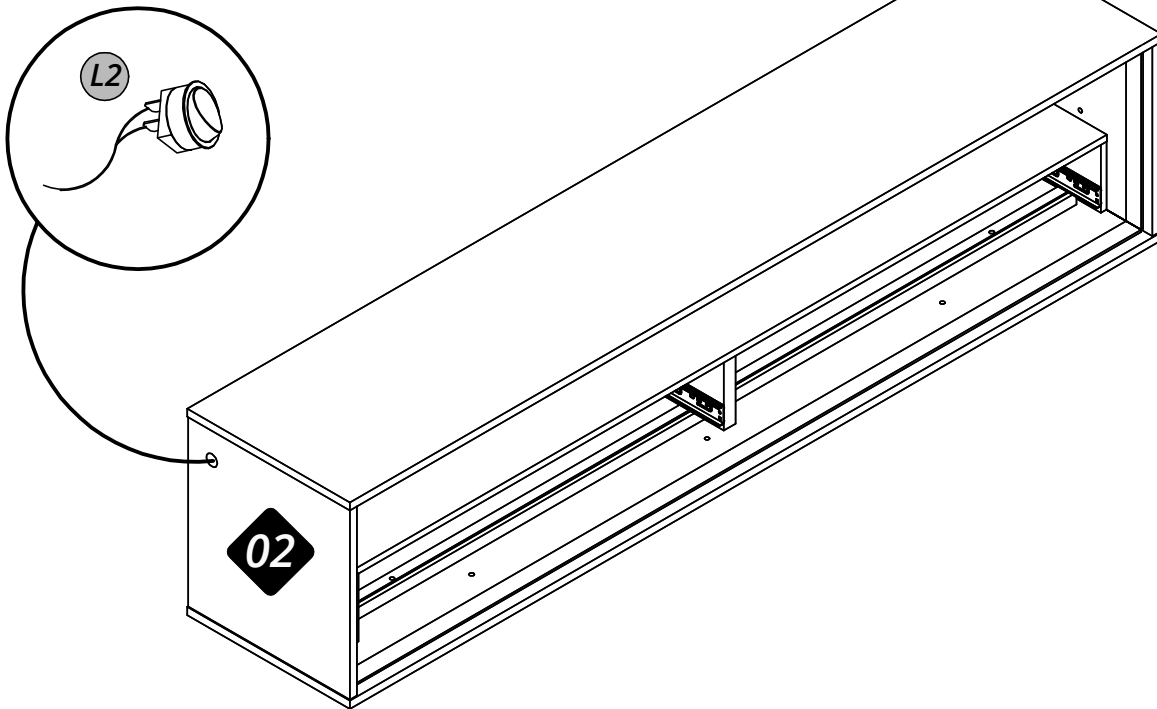

Encaixar o botão liga/desliga (L2) na peça nº 02.

Montar el botón de encendido/apagado (L2) en la pieza nº 02.

16

Fit the on/off button (L2) on part nº 02.

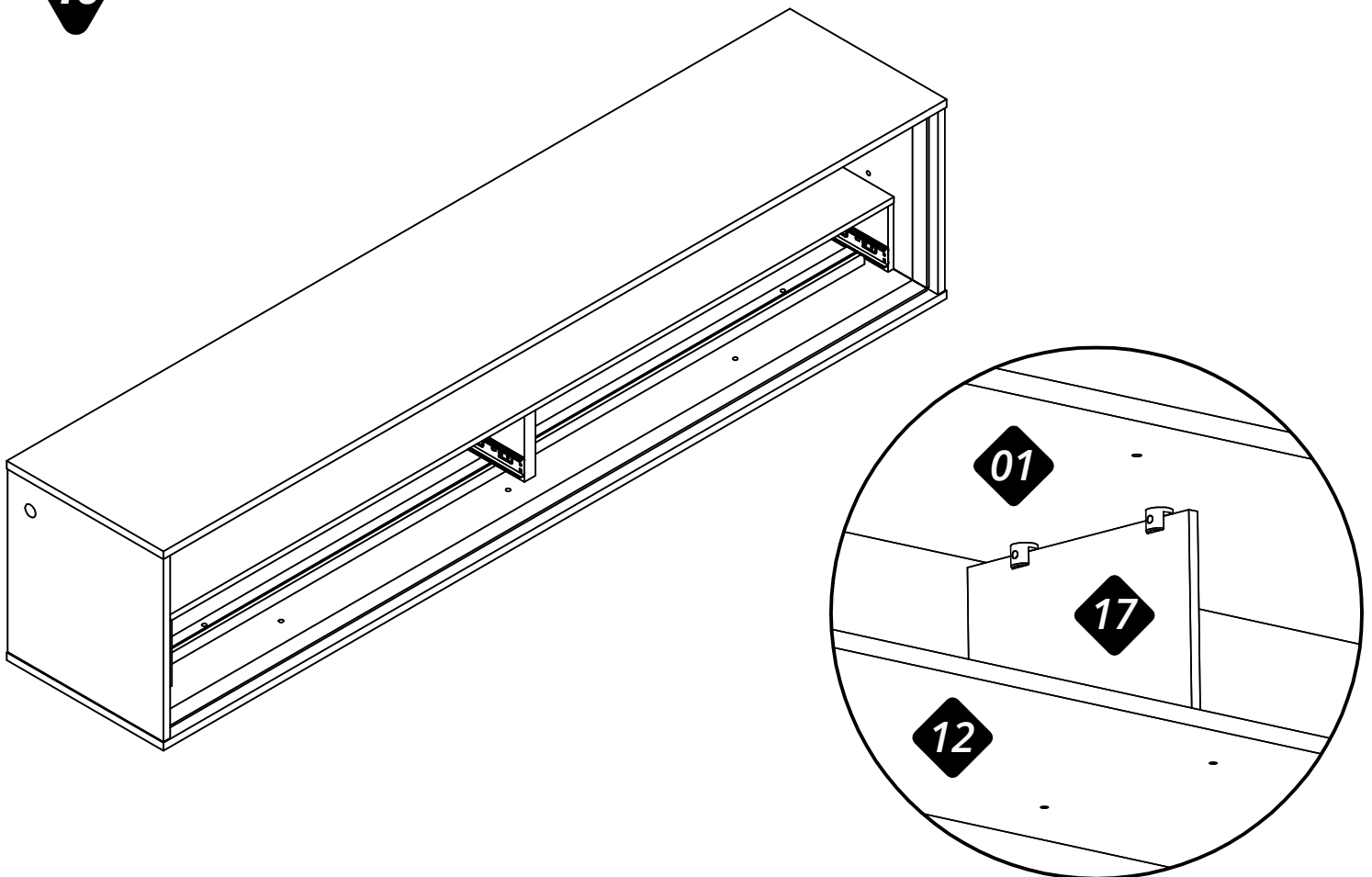

17

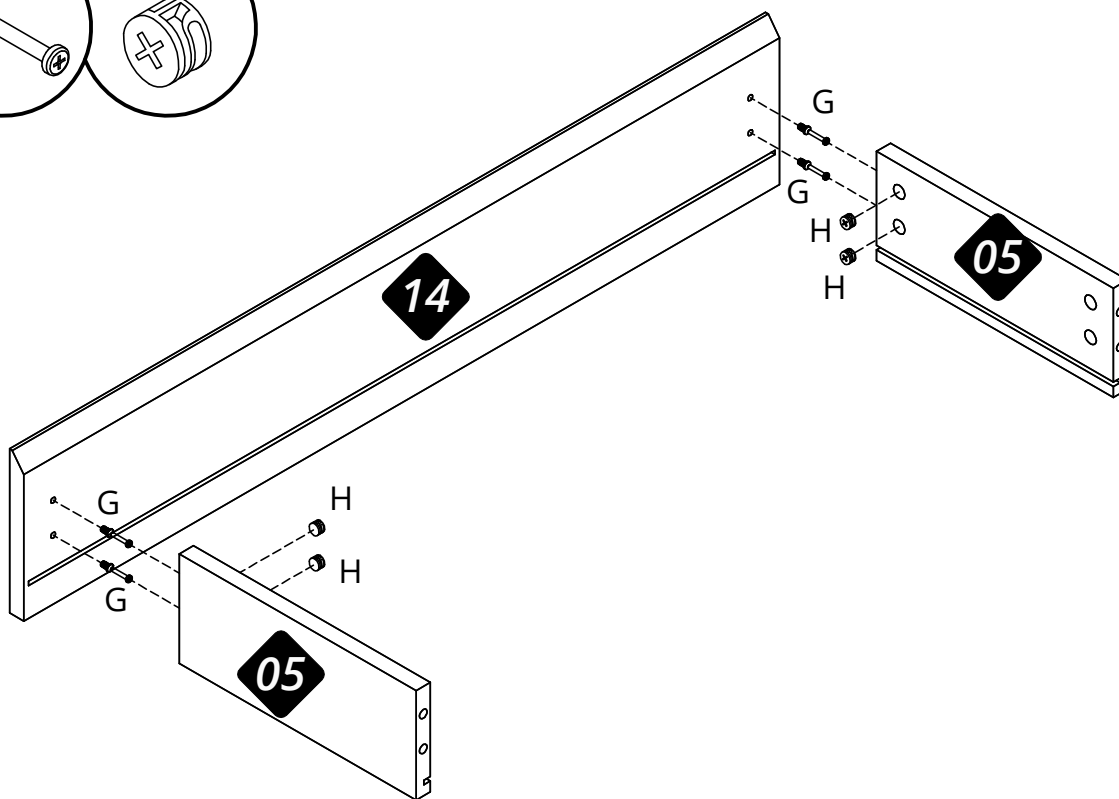
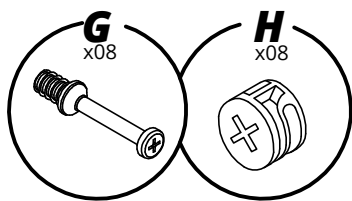

18

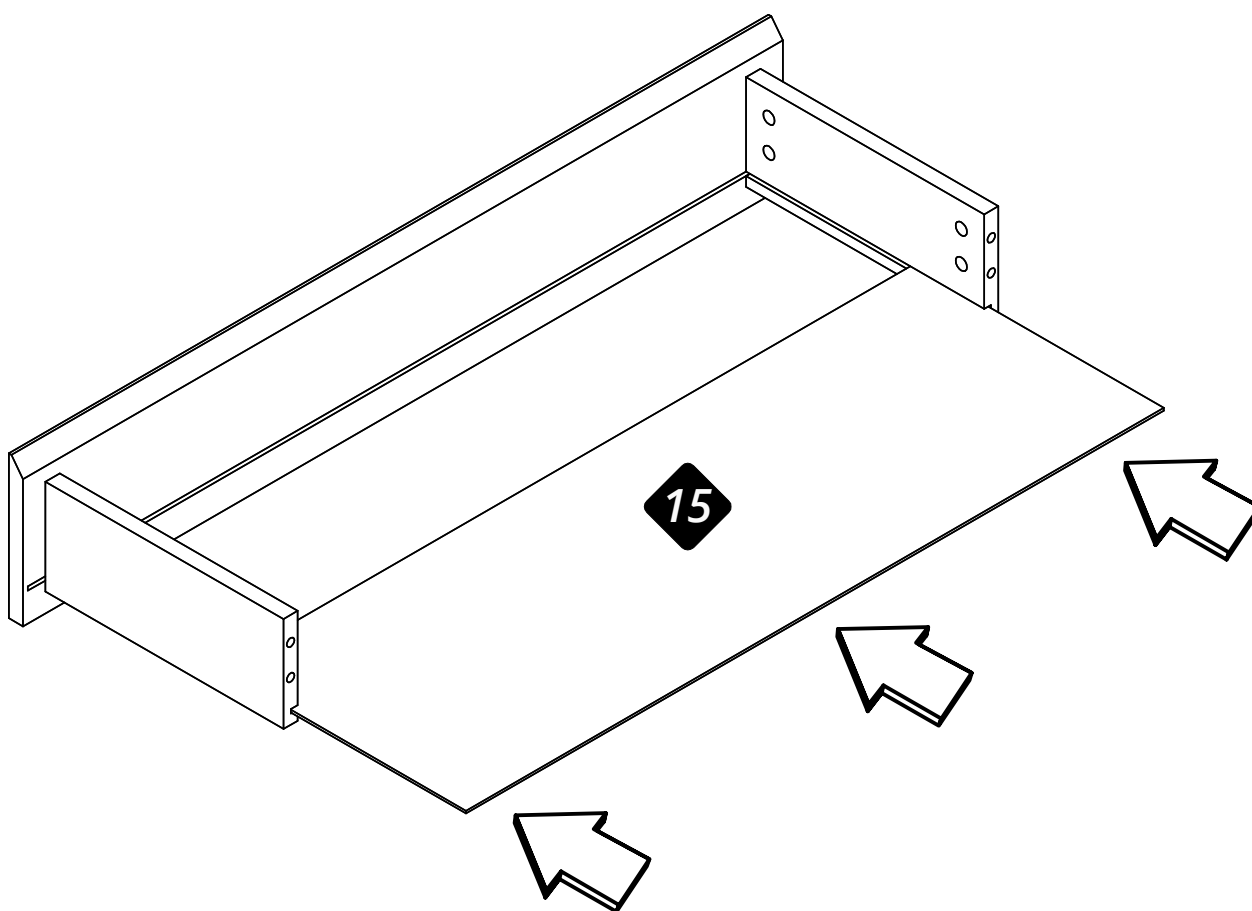

19

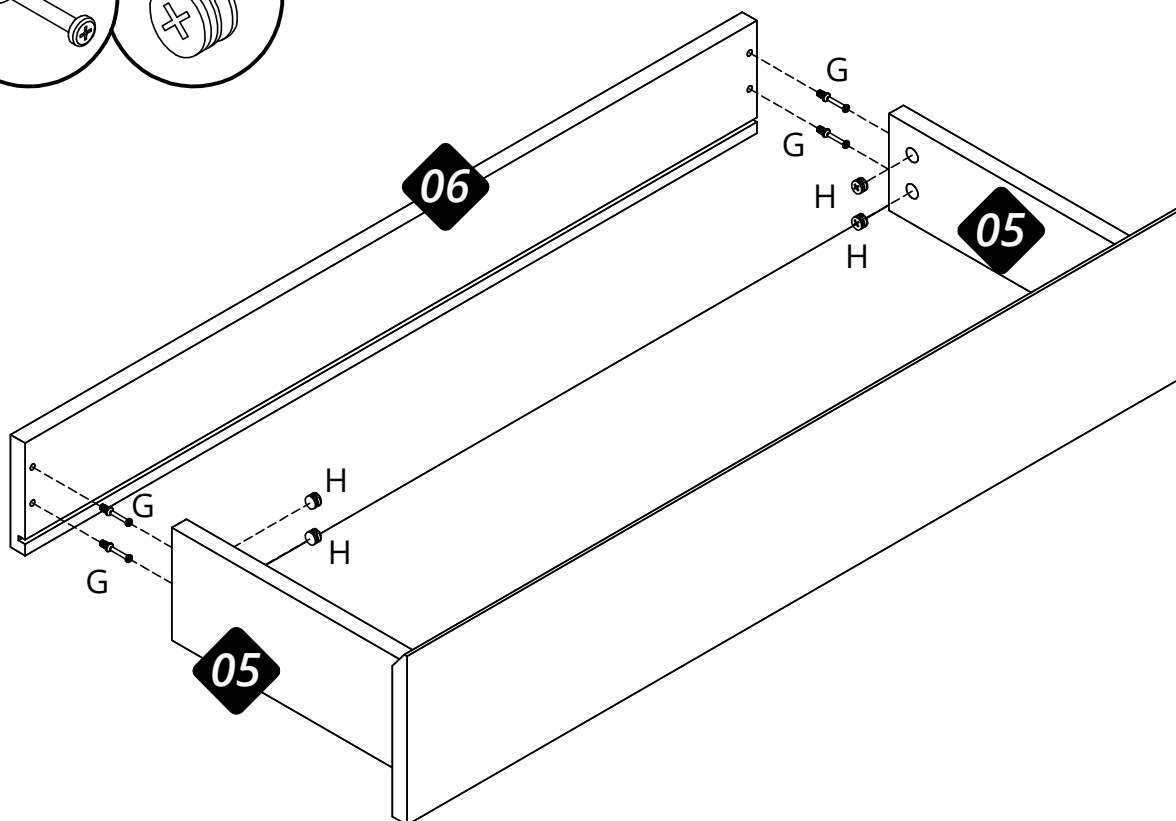
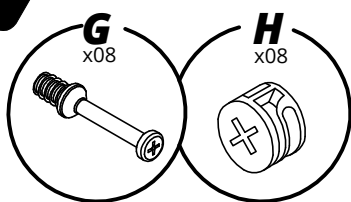

20

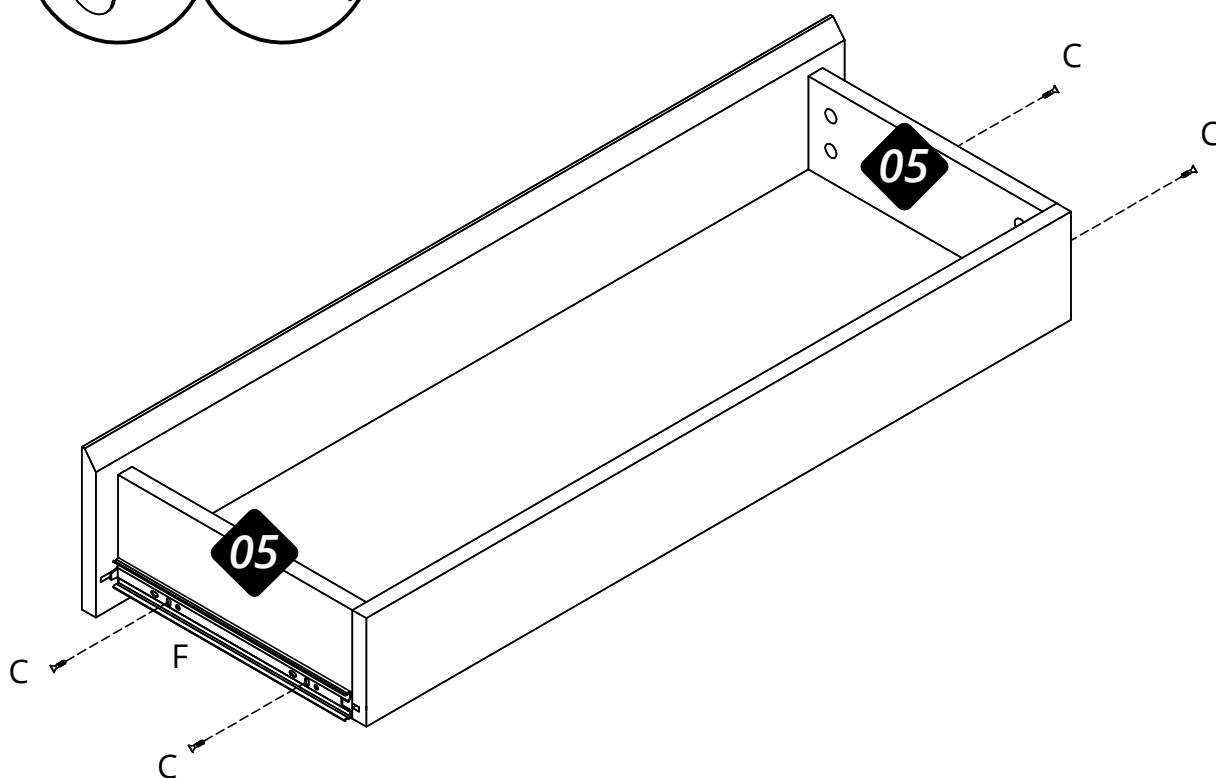
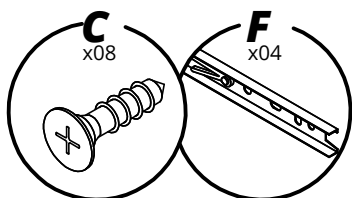

21

Instalação do kit cadeira* (vendido separadamente).

Instalación del kit silla * (se vende por separado).

Installing the kit chair (sold separately).

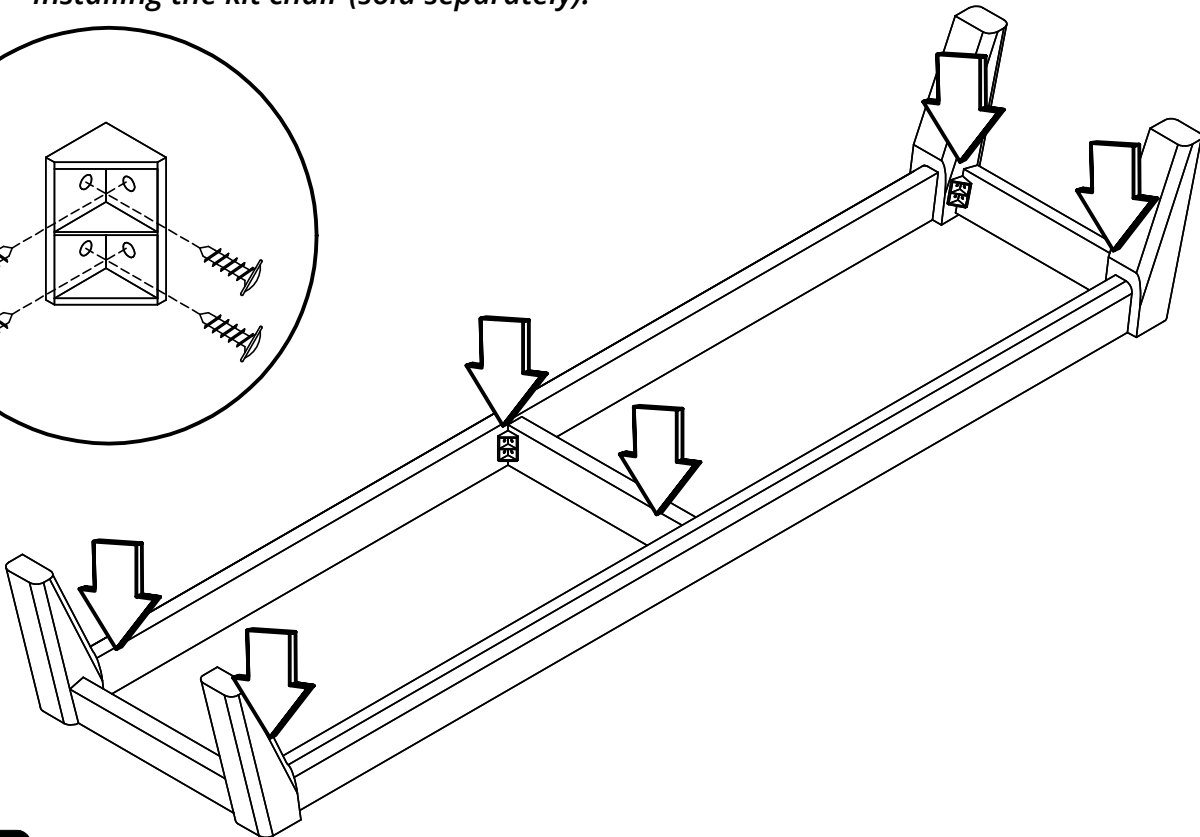
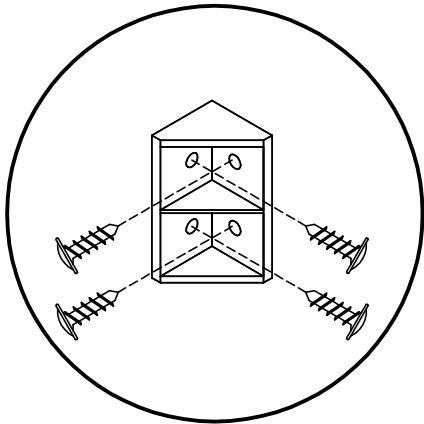

22

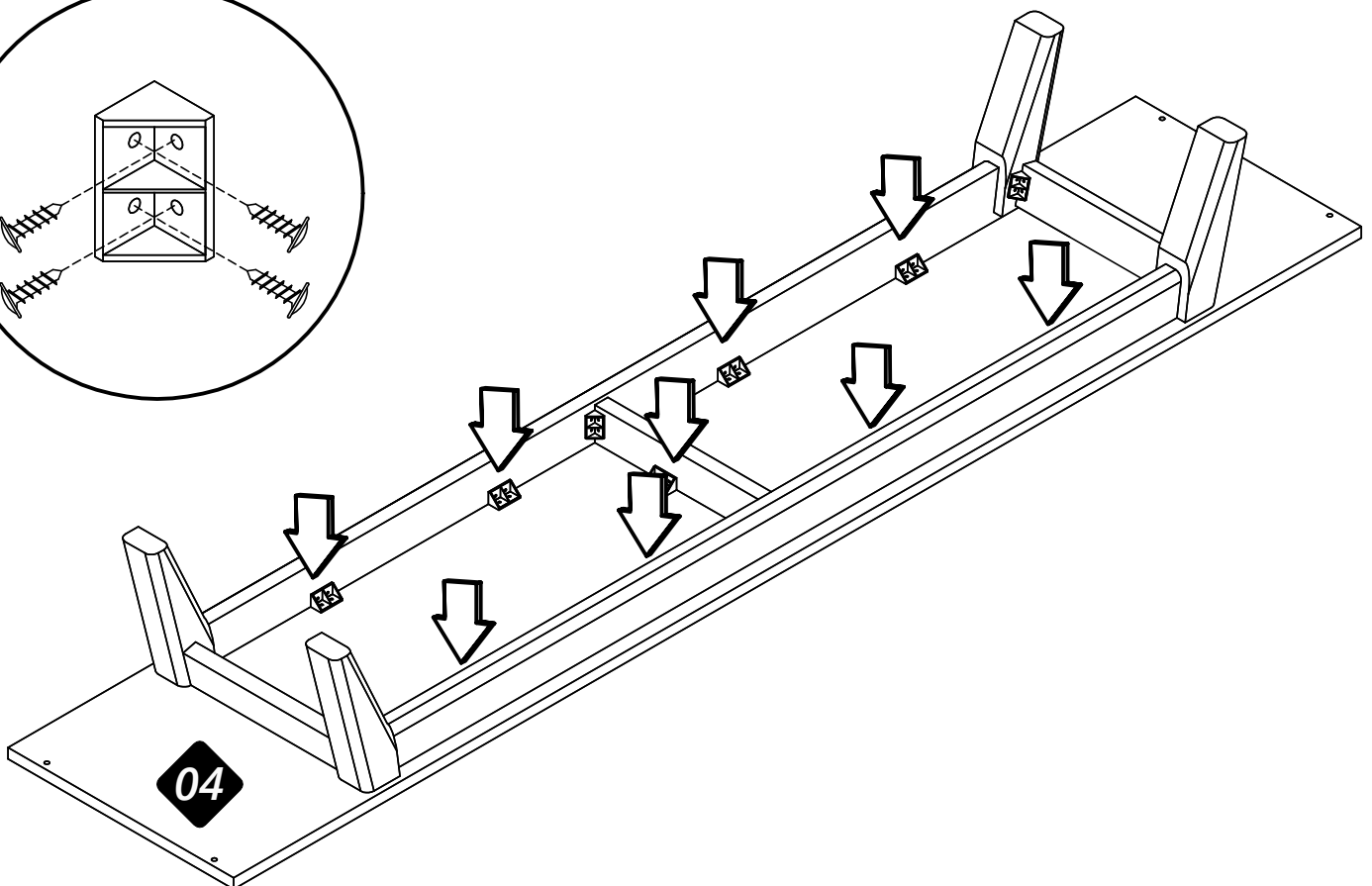
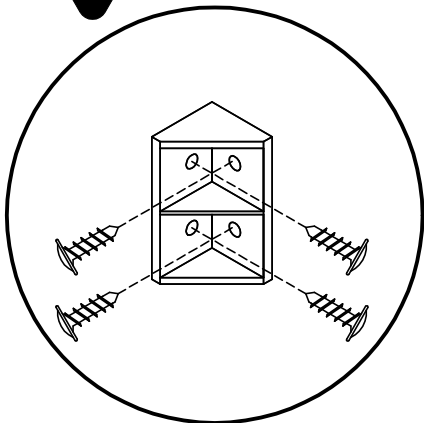

23

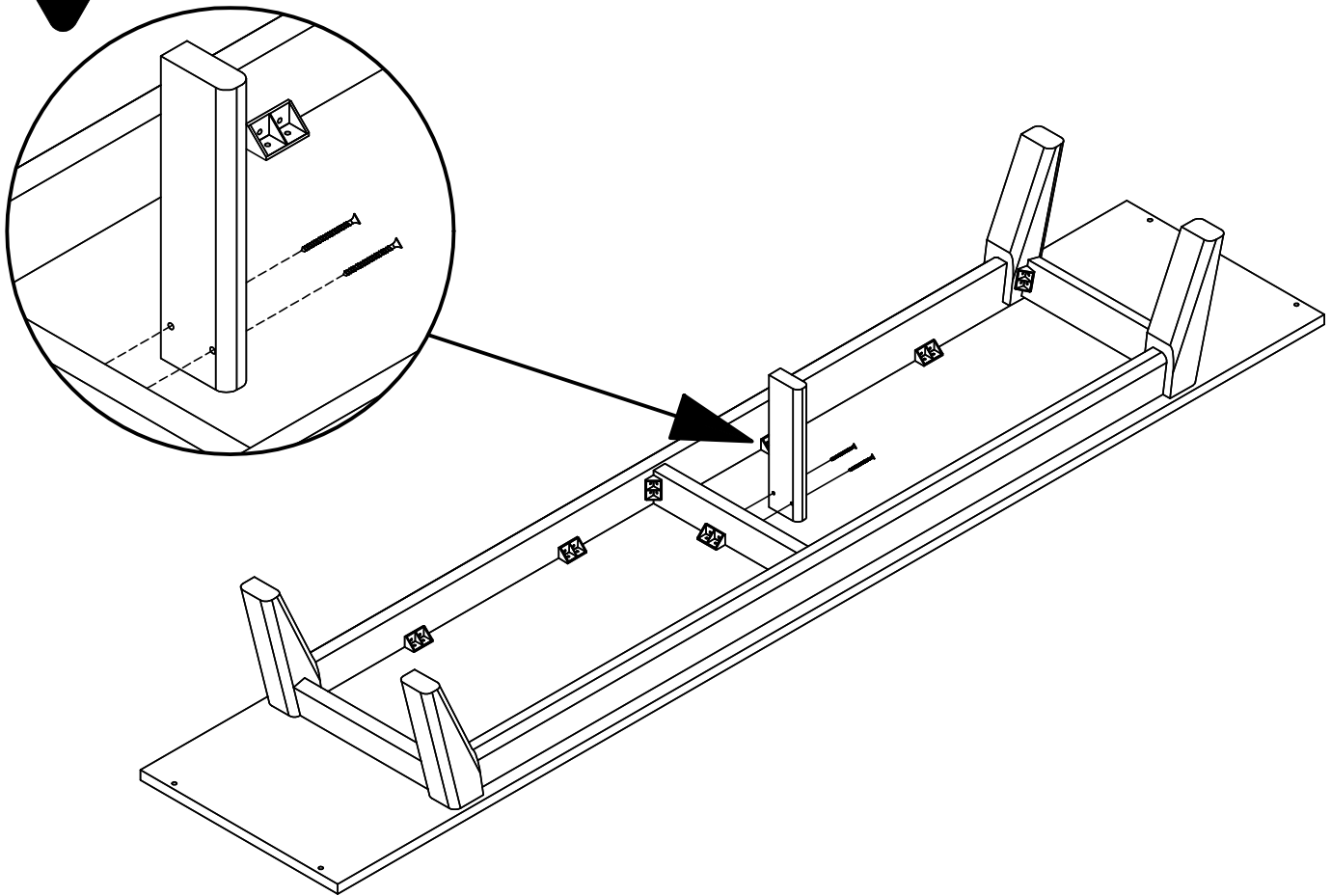

24

Instalação do kit rodízio (vendido separadamente).*

Instalación del juego de ruedas (se vende por separado).*

Installing the furniture wheel (sold separately).

