

ASSEMBLY INSTRUCTIONS MANUAL DE MONTAGEM / INSTRUCCIONES DE ARMADO

BAHIA DRESSING TABLE

PENTEADEIRA BAHIA

TOCADOR BAHIA

Reference
Referência
Referencia

190184

Revised
Revisão
Revisión

01



ENGLISH
PORTUGUÊS
ESPAÑOL

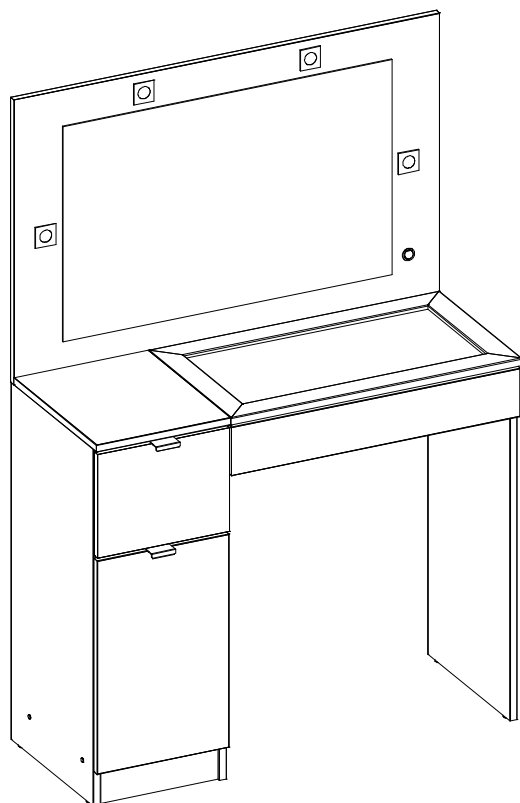

MAXIMUM RECOMMENDED WEIGHT
BEING THIS EVENLY DISTRIBUTED.

PESO MÁXIMO RECOMENDADO SENDO
ESTE DISTRIBUÍDO UNIFORMEMENTE.

PESO MÁXIMO RECOMENDADO SIENDO
ESTE UNIFORMEMENTE DISTRIBUIDO.

	LB	KG
—		
C	6	3
D	11	5

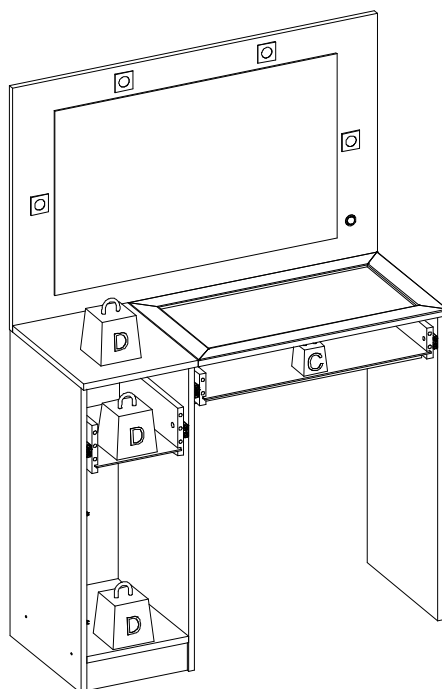

Nº	Measures_Inches	Medidas_cm	Qty./Qtd.
01	11 1/8 x 13 3/4 x 5/8	28.4 x 35.0 x 1.5	1
02	9 7/8 x 13 3/4 x 5/8	25.1 x 34.8 x 1.5	1
03	29 1/8 x 13 3/4 x 5/8	74.0 x 34.8 x 1.5	1
06	9 7/8 x 2 3/4 x 5/8	25.1 x 7.0 x 1.5	1
07	9 1/4 x 23 5/8 x 5/8	23.5 x 60.0 x 1.5	1
08	35 3/8 x 23 1/4 x 5/8	90.0 x 59.0 x 1.5	1
09	11 x 17 3/8 x 5/8	27.9 x 44.2 x 1.5	1
10	11 x 8 1/2 x 5/8	27.9 x 21.5 x 1.5	1
11	24 x 3 7/8 x 5/8	61.1 x 10.0 x 1.5	1
12	11 3/4 x 3 x 5/8	30.0 x 7.5 x 1.5	1
13	11 3/4 x 3 x 5/8	30.0 x 7.5 x 1.5	1
14	7 3/4 x 4 1/2 x 5/8	19.6 x 11.5 x 1.5	1
15	21 1/2 x 3 x 5/8	54.5 x 7.5 x 1.5	1
16	11 3/4 x 8 1/4 x 1/8	29.9 x 21.0 x 0.3	1
17	22 x 11 3/4 x 1/8	55.9 x 29.9 x 0.3	1
18	26 3/4 x 10 5/8 x 1/8	68.0 x 27.1 x 0.3	1
19	29 1/8 x 13 3/4 x 5/8	74.0 x 34.8 x 1.5	1
20	2 3/4 x 23 5/8 x 5/8	7.0 x 60.0 x 1.5	1
21	29 1/8 x 13 3/4 x 5/8	74.0 x 34.8 x 1.5	1
60	24 1/4 x 13 3/4 x 5/8	61.6 x 35.0 x 1.5	1
106	11 3/4 x 4 1/2 x 5/8	30.0 x 11.5 x 1.5	1
107	11 3/4 x 4 1/2 x 5/8	30.0 x 11.5 x 1.5	1

PARTS IDENTIFICATION IDENTIFICAÇÃO DAS PEÇAS / IDENTIFICACIÓN DE LAS PIEZAS

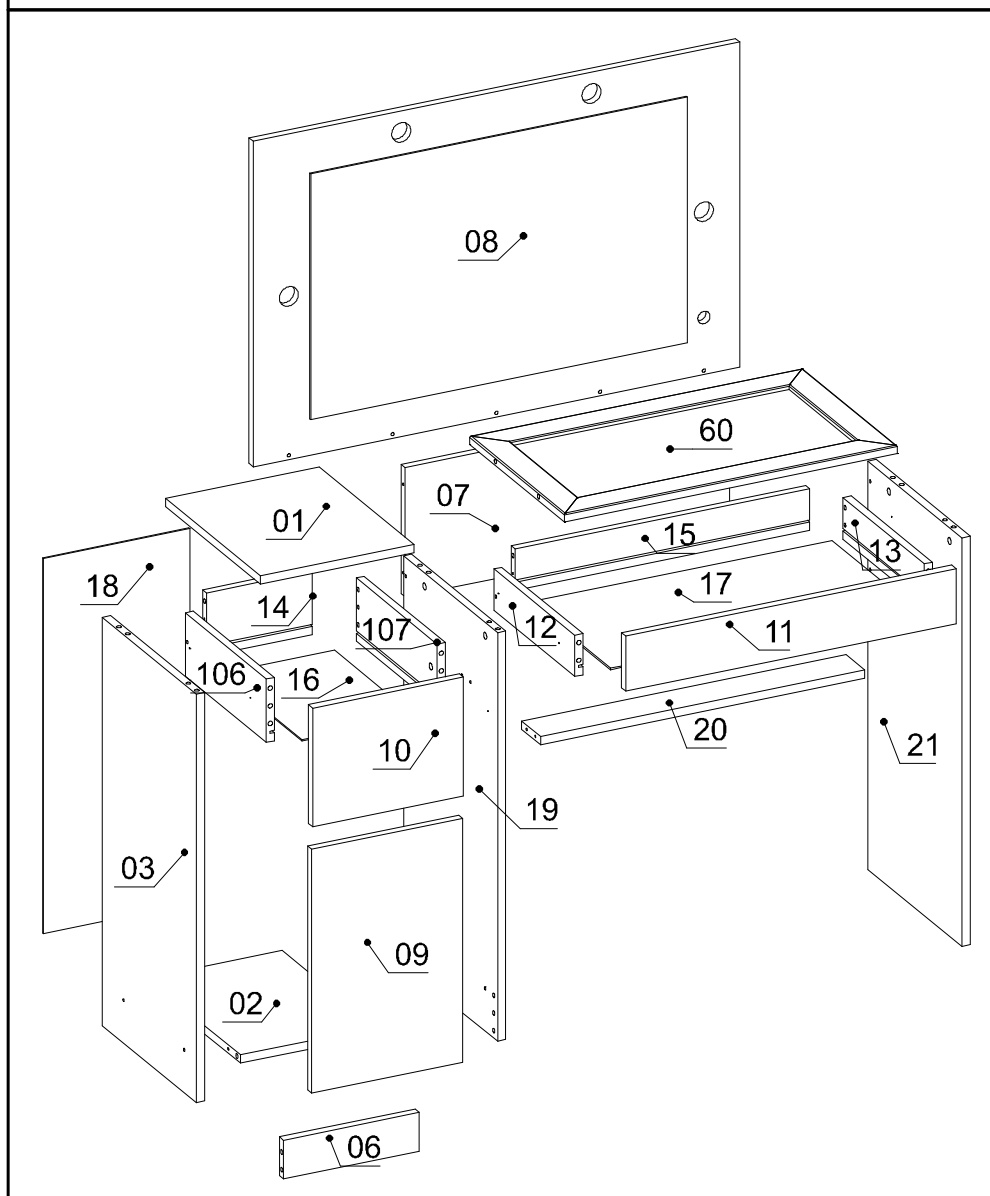

YOU WILL NEED / VOCÊ VAI PRECISAR DE / USTED NECESITARÁ

Tools not supplied / Ferramentas não fornecidas / Herramientas no incluidas

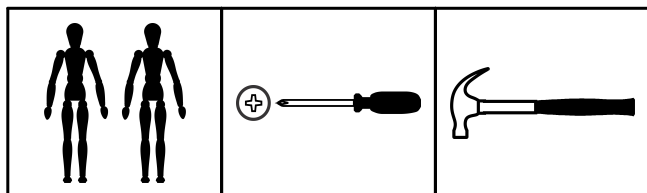

2 People
2 Pessoas
2 Personas

Screwdriver Phillips
Chave Phillips
Destornillador cruz

Hammer
Martelo
Martillo

















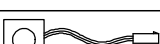
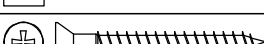

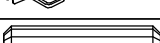

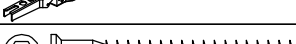

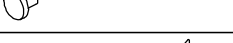

The separation of the accessories before you start the assembly will facilitate the same. In case of doubt on the size of the screws and bolts, use the ruler to bottom of page 3.

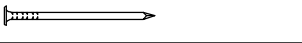
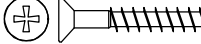
A separação dos acessórios antes de iniciar a montagem facilitará a mesma. Em caso de dúvida no tamanho dos parafusos e cavilhas, utilize a régua ao final da página 3.

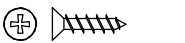
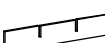
La separación de los accesorios antes de comenzar el armado facilitará el mismo. En caso de duda sobre el tamaño de los tornillos y taquetes, utilice la regla al pie de página 3.

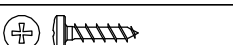
IDENTIFICATION OF ACCESSORIES IDENTIFICAÇÃO DOS ACESSÓRIOS/ IDENTIFICACIÓN DE ACCESORIOS

A1		Glue / Cola / Pegamento	13 g	1
A2		Small plastic foot / Sapata redonda / Pie plástico	14 mm	6
A3		Trapeze / Trapézio / Trapecio	-	2
A4		Metalic bracket / Cantoneira de metal / Suporte de metal	22x22 mm	2
A14		Junction of tops / Junção de tampos / Unión de tapas	40x90 mm	2
A15A		Electric cable / Chicote elétrico / Cable eléctrico	-	1
A15B		Switch / Interruptor / Interruptor	-	1
A15C		Light fixture / Luminária LED / Luminaria	-	4
D		Flat head screw / Parafuso chato / Tornillo de cabeza plana	4,0x40 mm	5
D5		Hinge shim / Calço dobradiça / Bisagra de calce	-	2
E		Wooden dowel / Cavilha / Taquete	8x30 mm	30
F9		Metal hinge straight / Dobradiça reta / Bisagra recta	26 mm	2
G		Structural screw / Parafuso estrutural / Tornillo estructural	5,0x50 mm	12
H		Allen key / Chave allen / Liave allen	3 mm	1
I		Structural screw cover/Tampa parafuso estrutural/Tapa tornillo estructural	-	8
J		Simple minifix screw / Haste minifix simples / Tornillo minifix simple	-	8
L		Drum lock / Tambor minifix / Tambor minifix	12 mm	8
M		Bore patch adhesive / Tapa furo adesivo / Tapones adhesivo	-	2
N		Nail / Prego / Clavo	10x10	22
O		Flat head screw / Parafuso chato / Tornillo de cabeza plana	4,5x45 mm	4
P		Pan head screw / Parafuso panela / Tornillo de pan	4,5x25 mm	2
P5		Flat head screw / Parafuso chato especial / Tornillo de cabeza plana	3,5x14 mm	4
Q14A		Drawer divider / Divisor de gavetas / Divisor de cajón	544mm	2
Q14B		Drawer divider / Divisor de gavetas / Divisor de cajón	284mm	4
S		Pan head screw / Parafuso panela / Tornillo de pan	3,5x14 mm	40
S10		Telescopic slide / Corrediça telescópica / Corredera telescópica	300 mm	4
X4		Handle / Puxador Stile Alfa / Tirador	32 mm	2

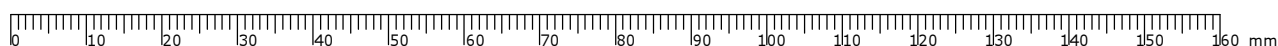

PRE-ASSEMBLE
PRÉ-MONTAGE / PRE ARMADO

01

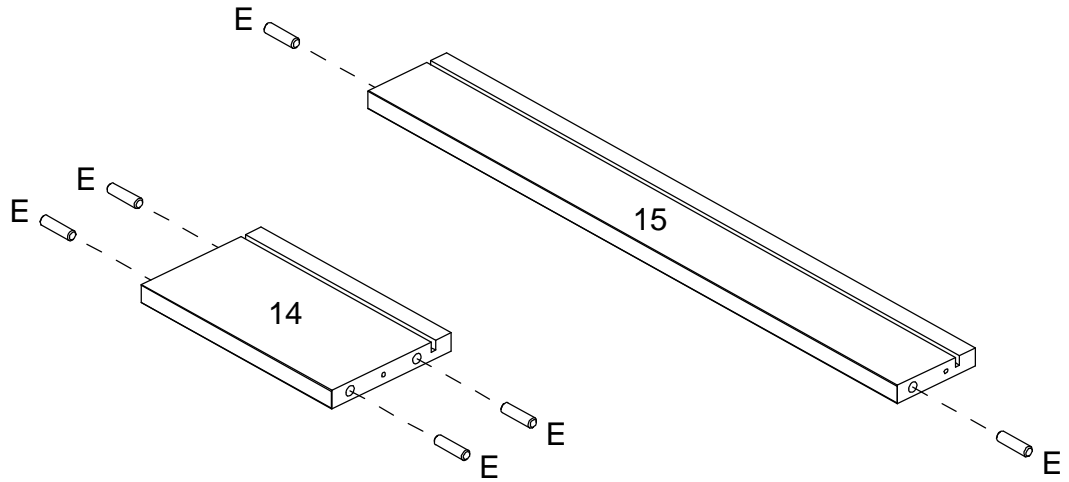
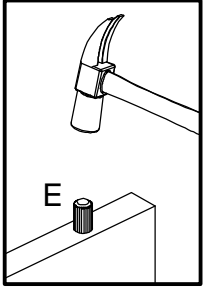

02

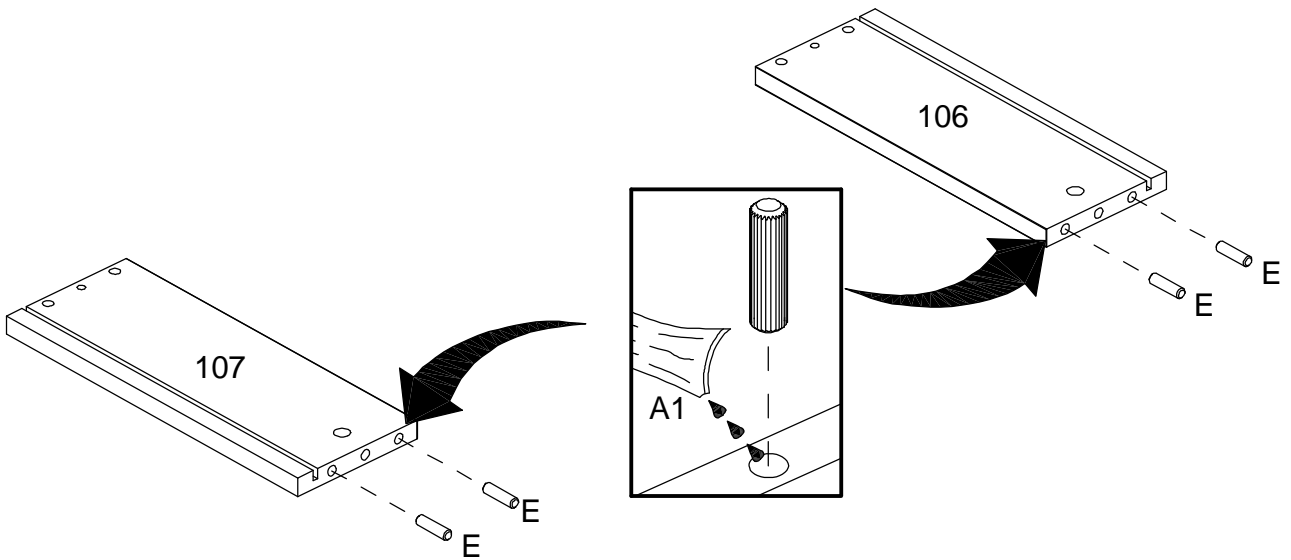

03

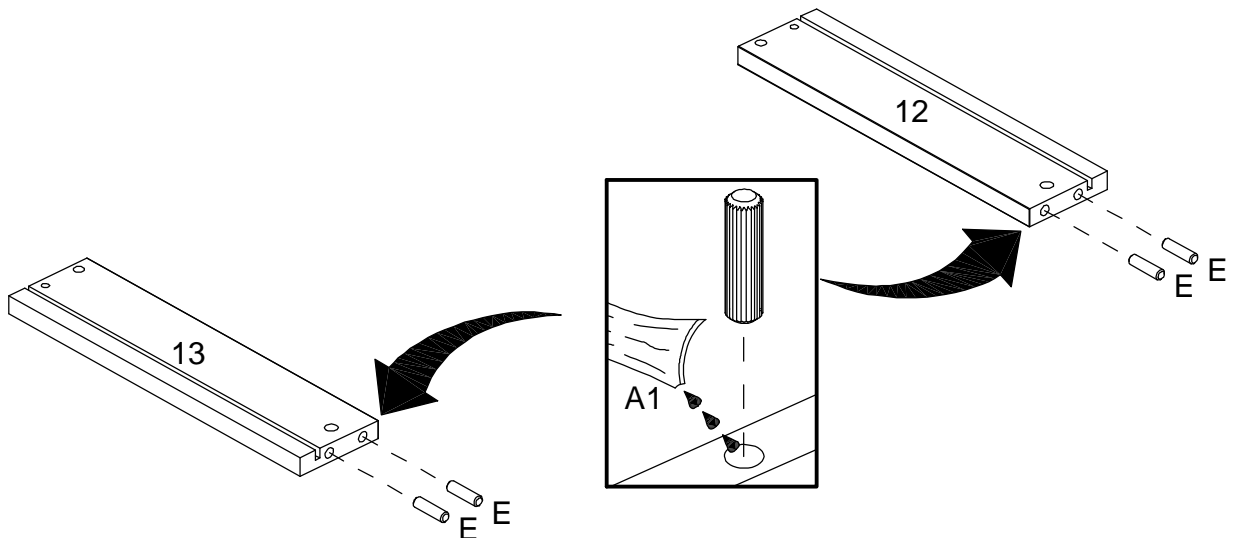

04

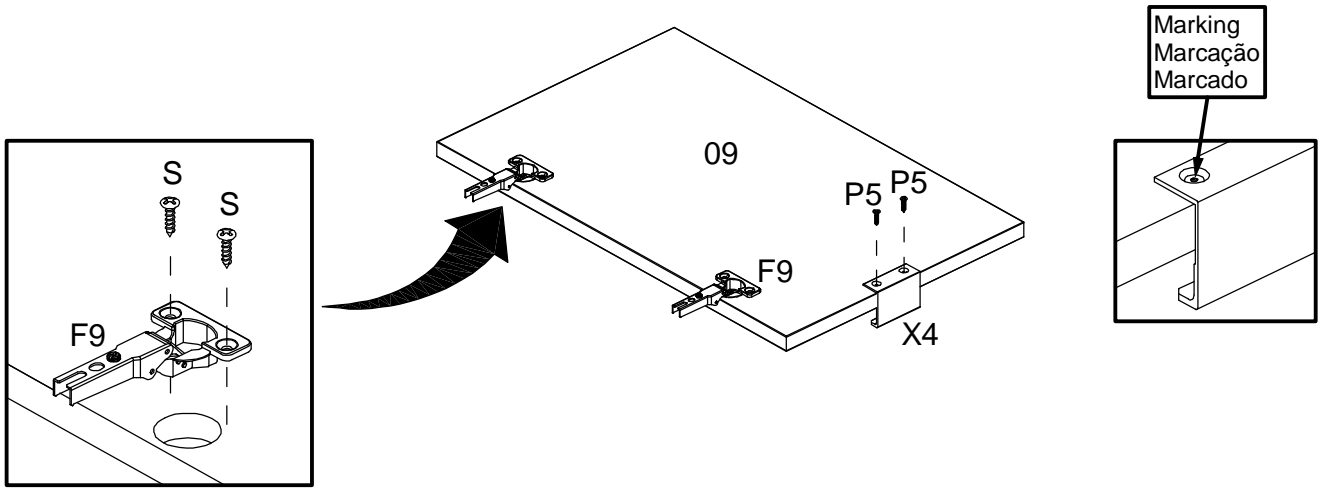

05

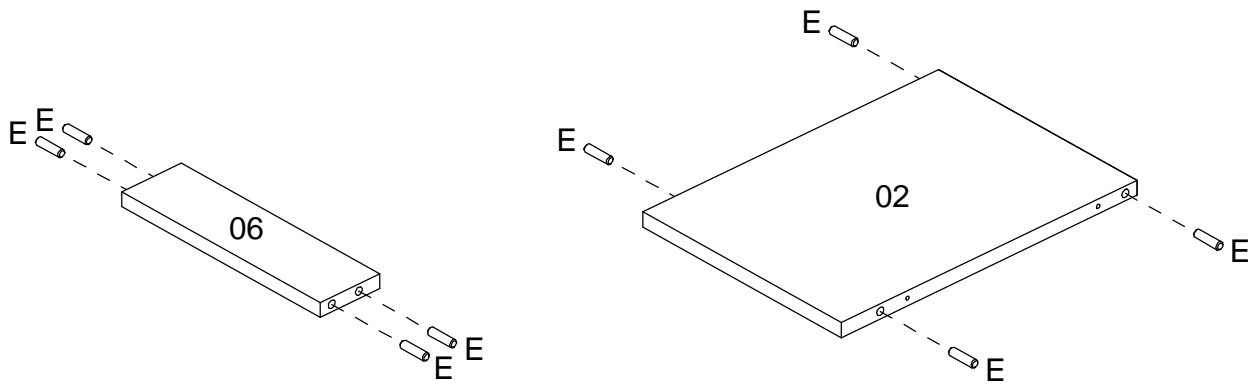

06

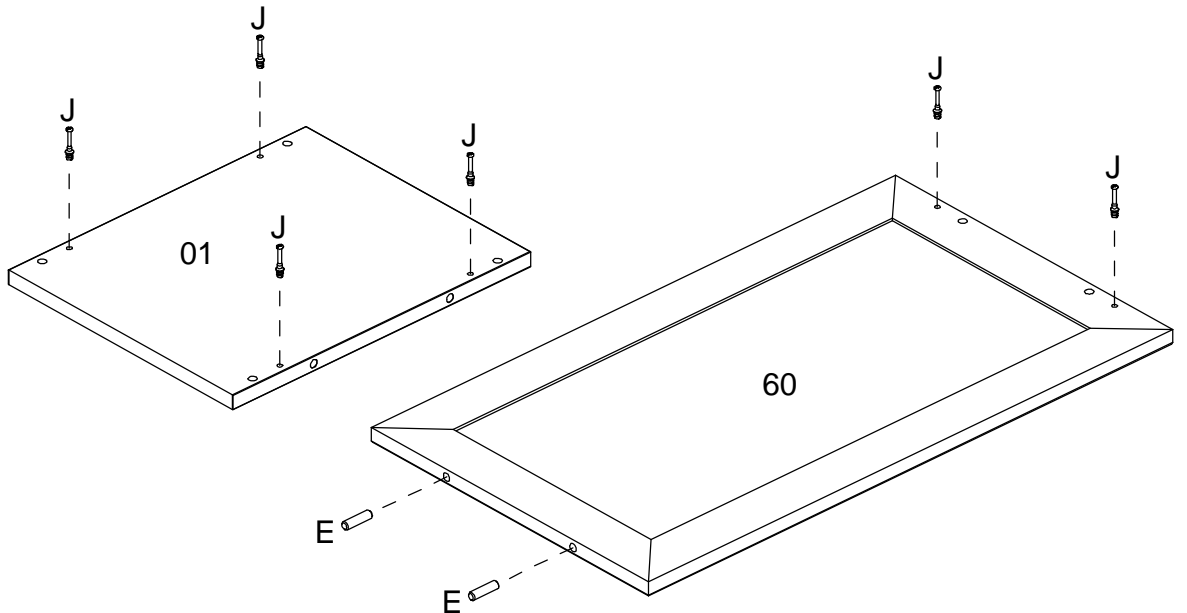
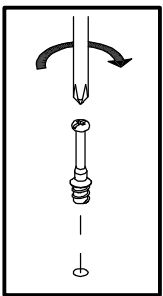

07

SEPARATE THE TWO PARTS OF THE METAL SLIDE TO THE ASSEMBLY FOLLOWING THE INSTRUCTIONS BELOW.
SEPARAR AS DUAS PARTES DA CORREDIÇA METÁLICA PARA A MONTAGEM SEGUINDO AS INSTRUÇÕES ABAIXO.
SEPARAR LAS DOS PARTES DE LA CORREDERA DE METAL PARA EL ARMADO Y SEGUIR A LAS INSTRUCCIONES ABAJO.

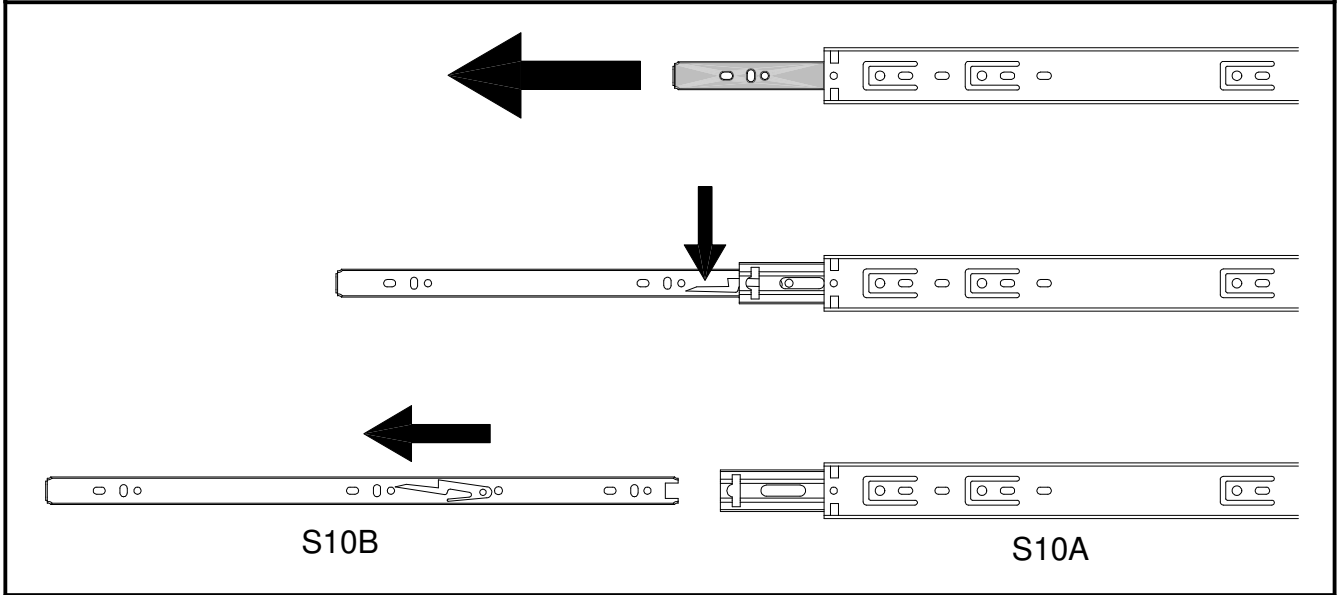

08

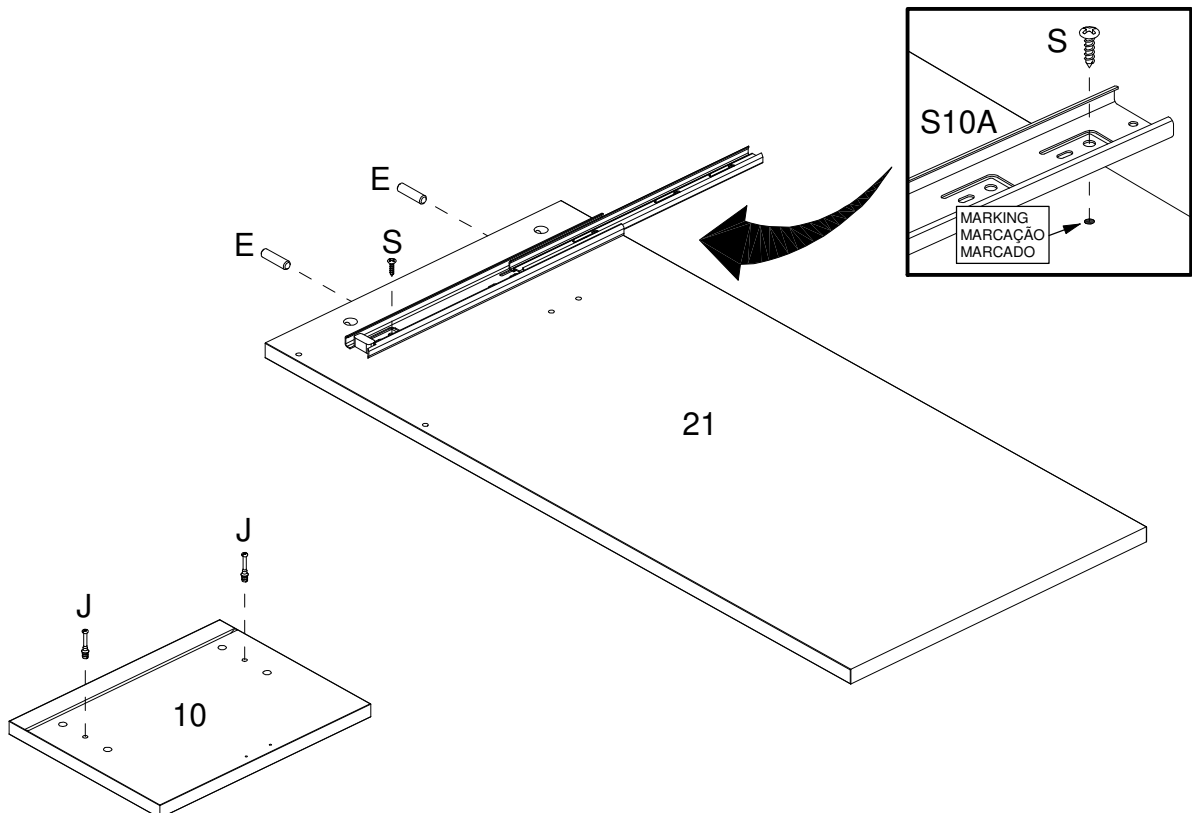

09

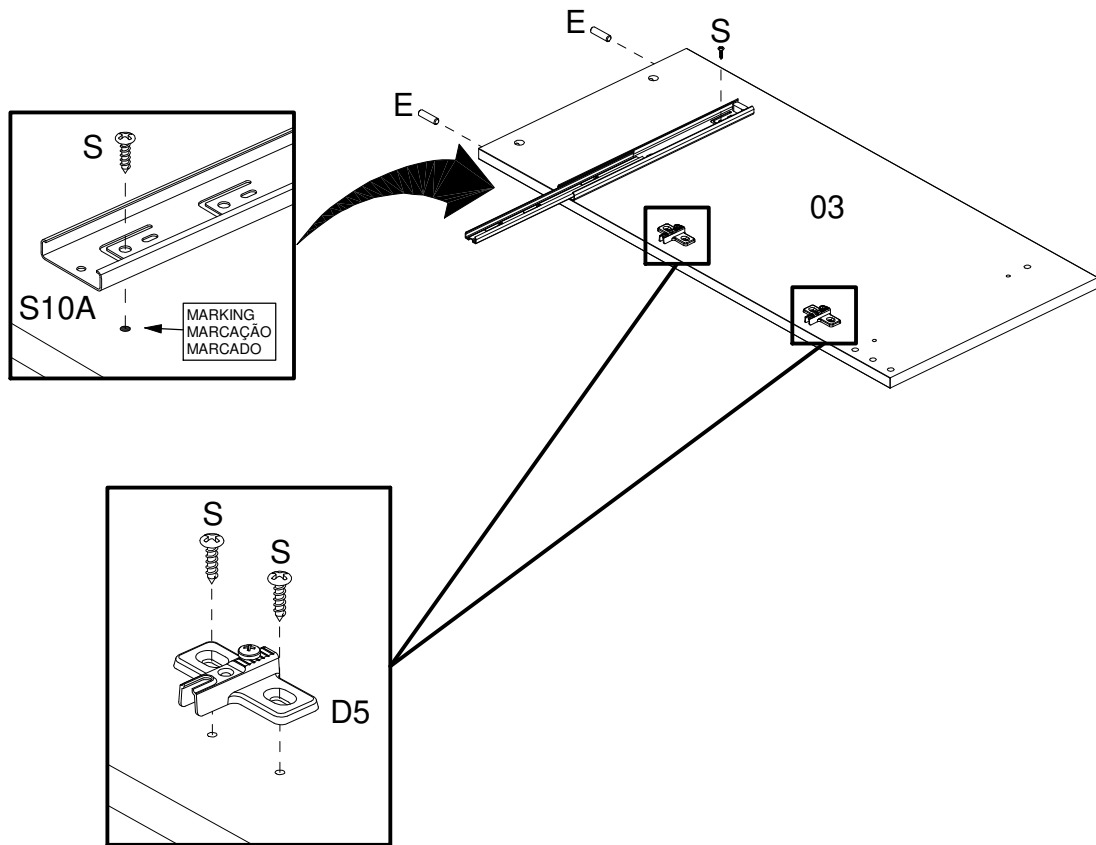

10

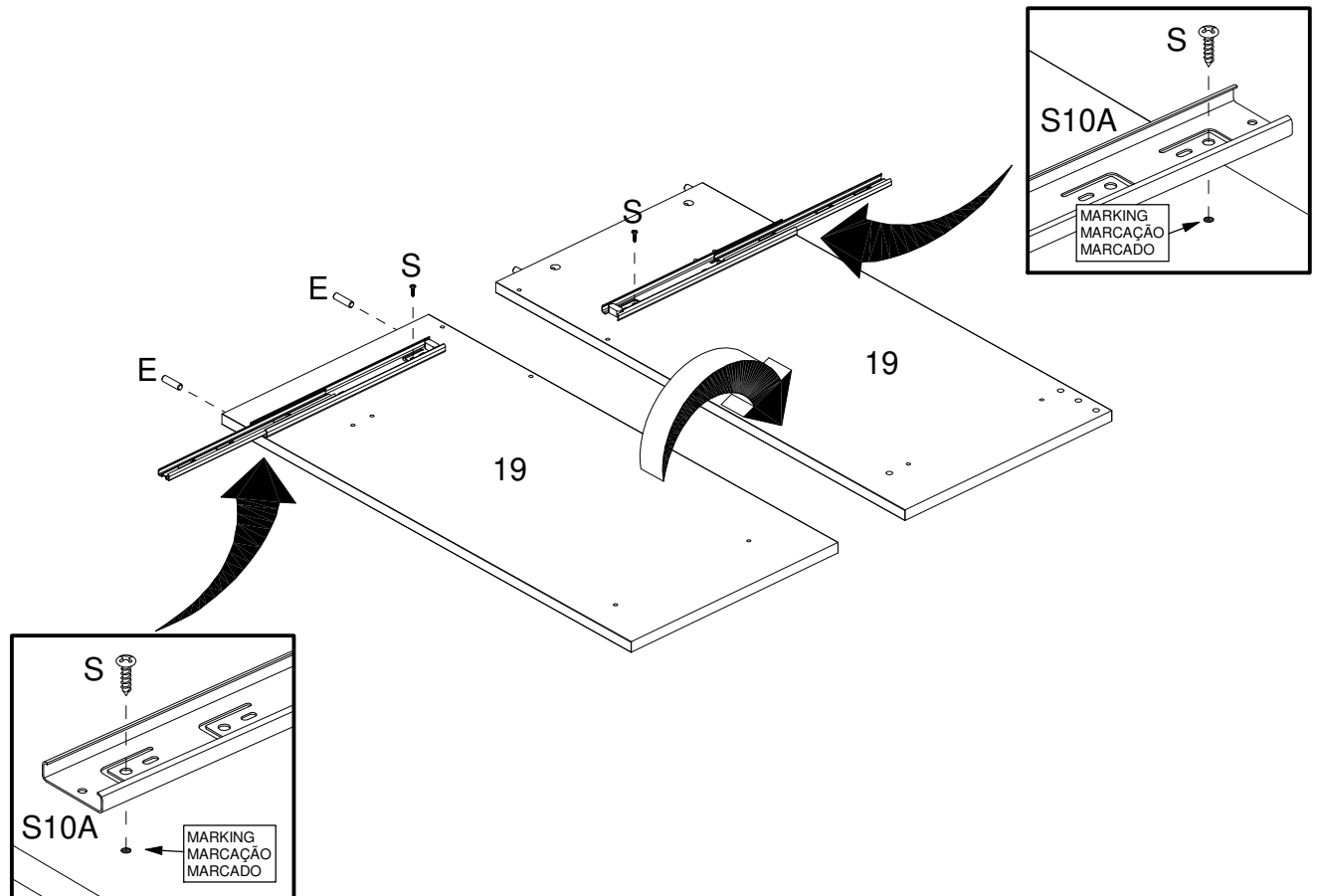

ASSEMBLY
MONTAGEM / ARMADO

11

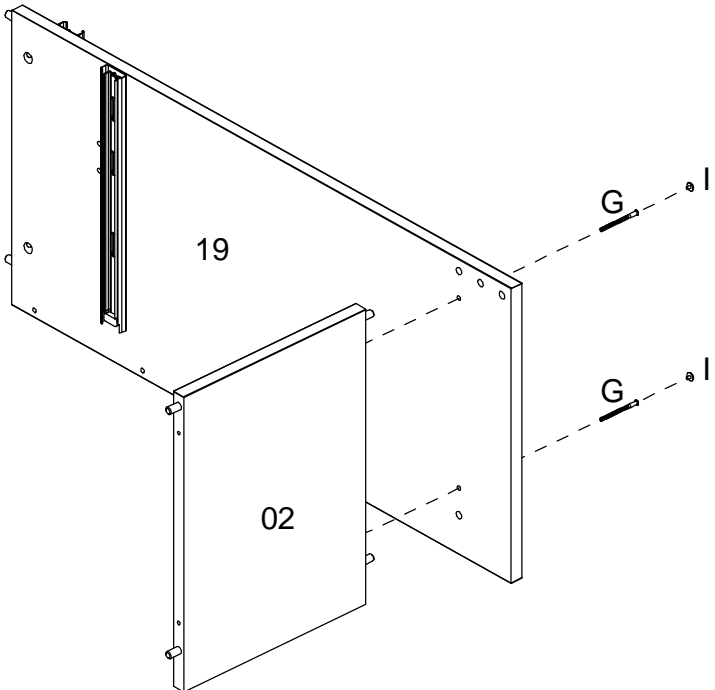
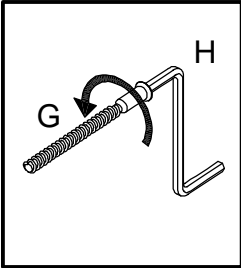

12

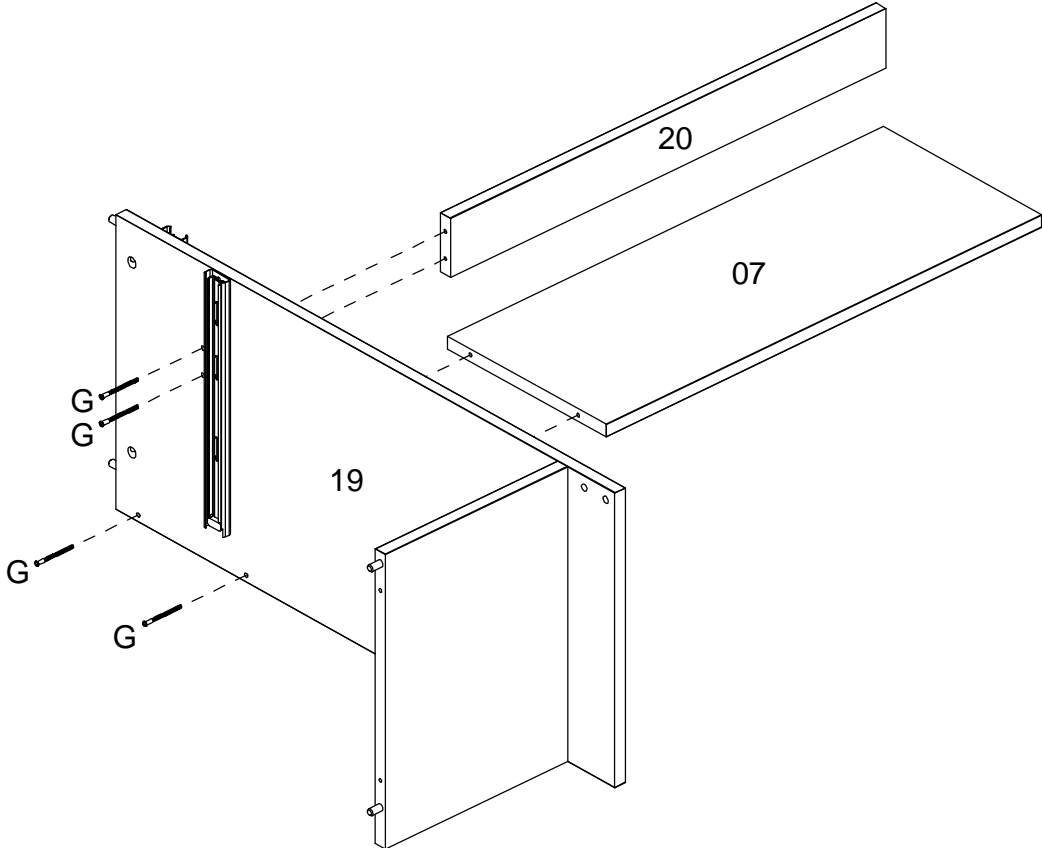

13

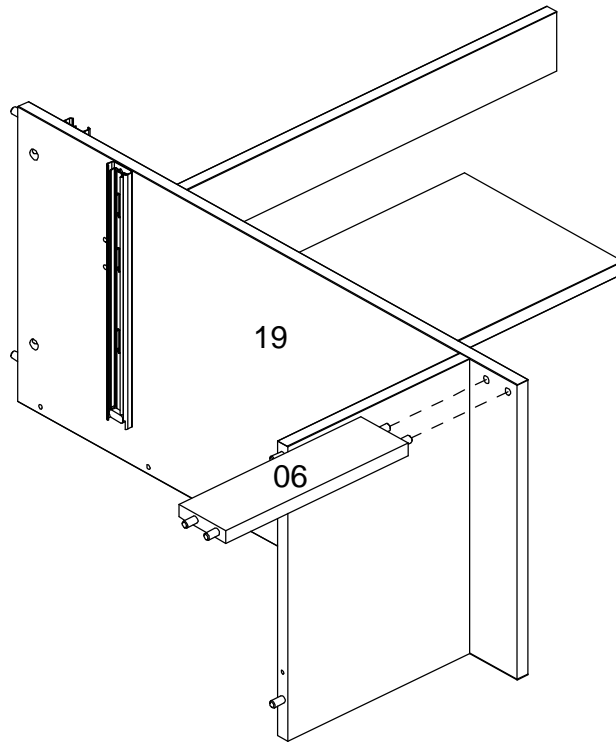

14

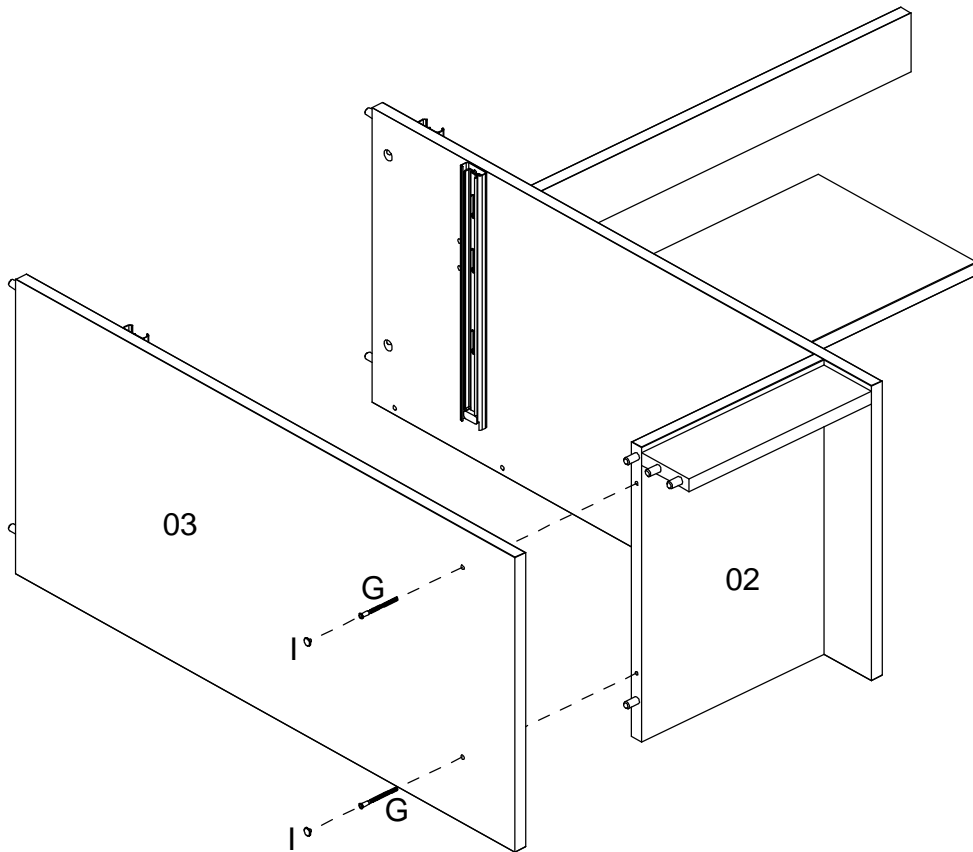

15

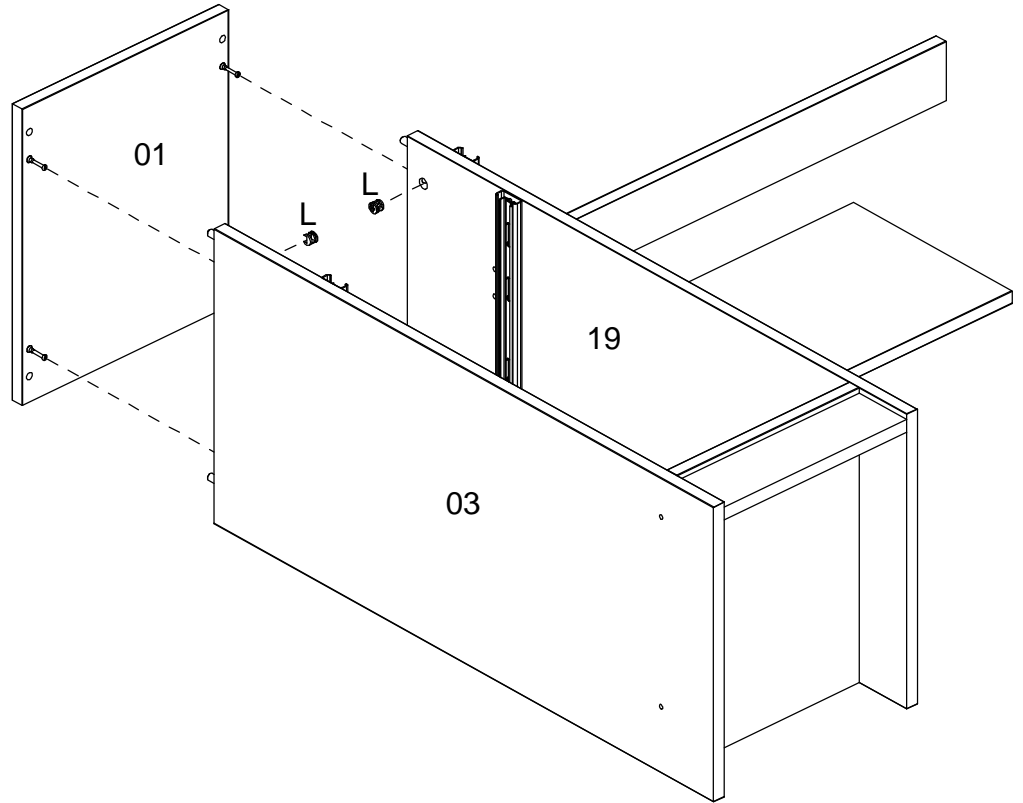
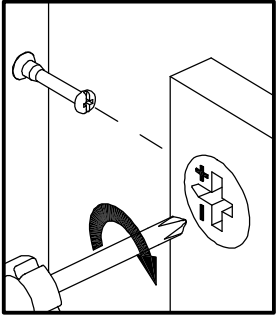

16

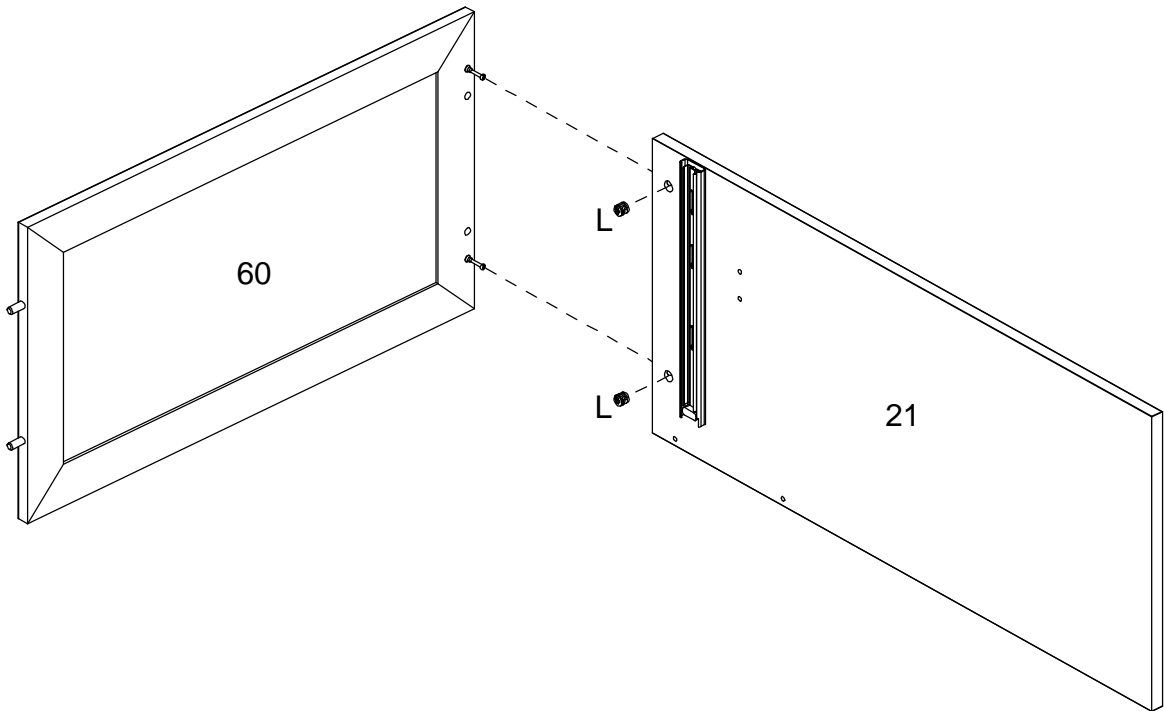

17

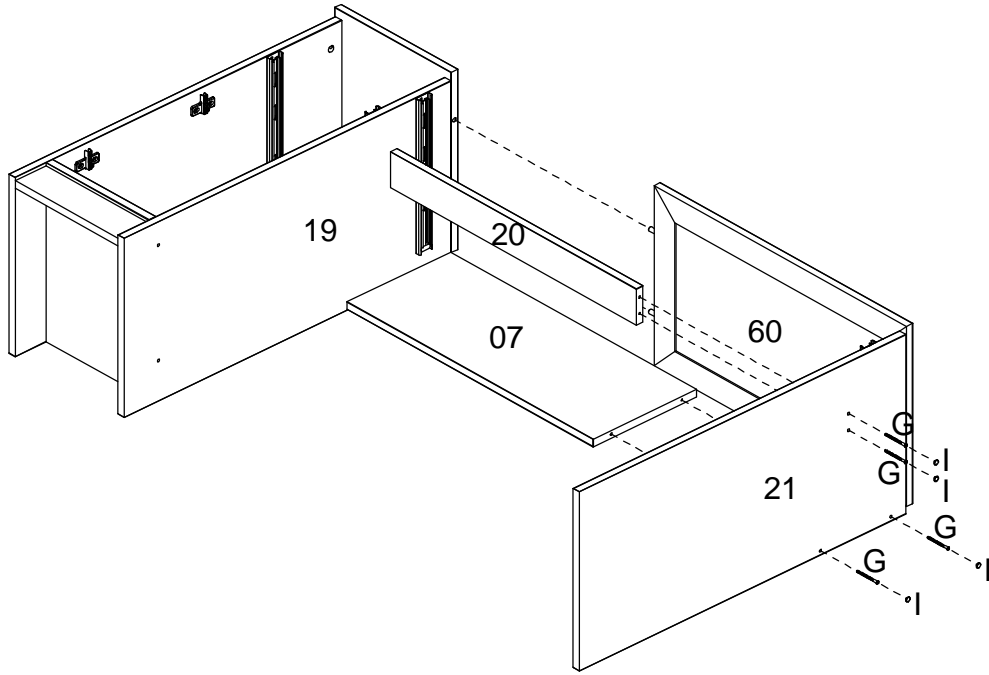

18

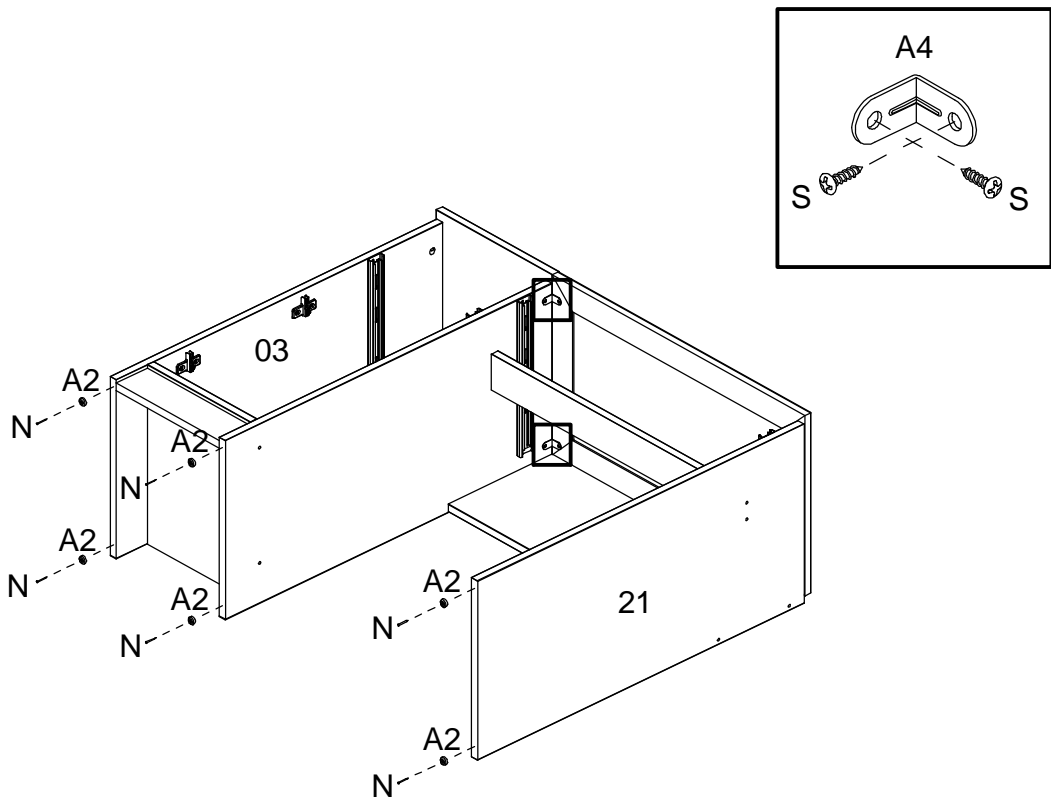

19

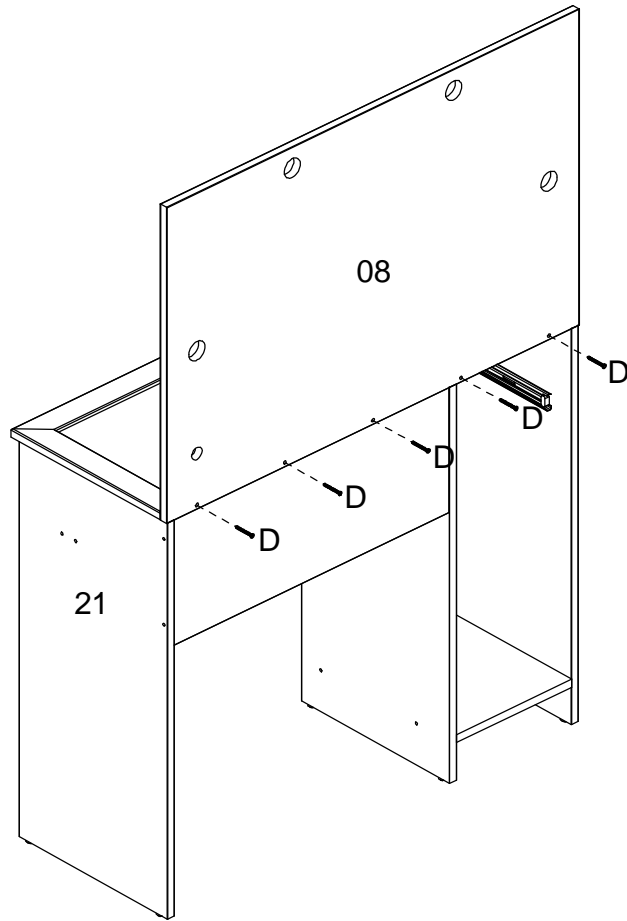

20

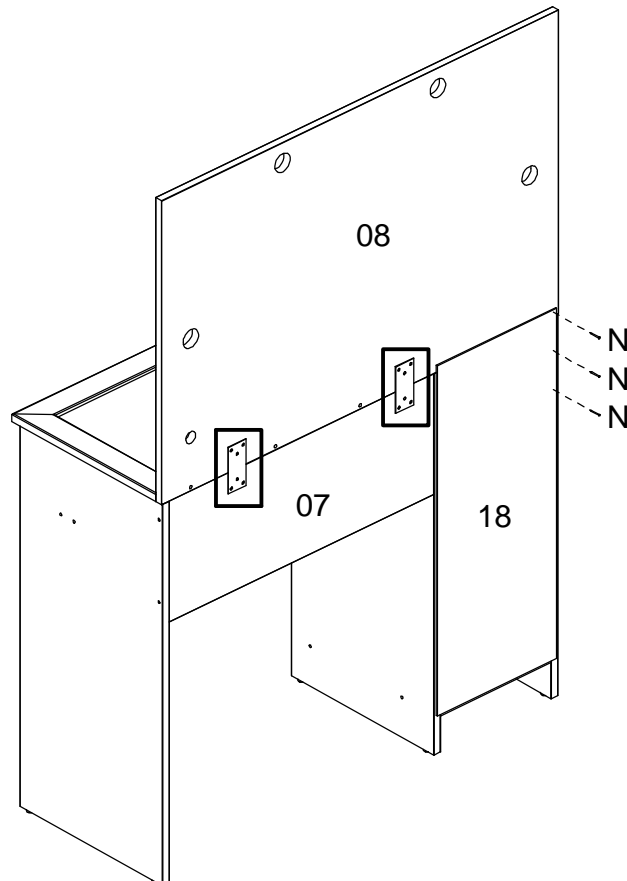
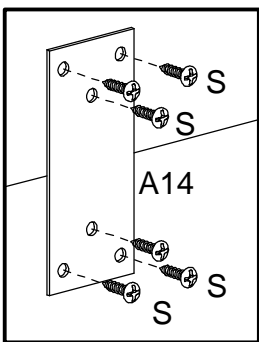

21

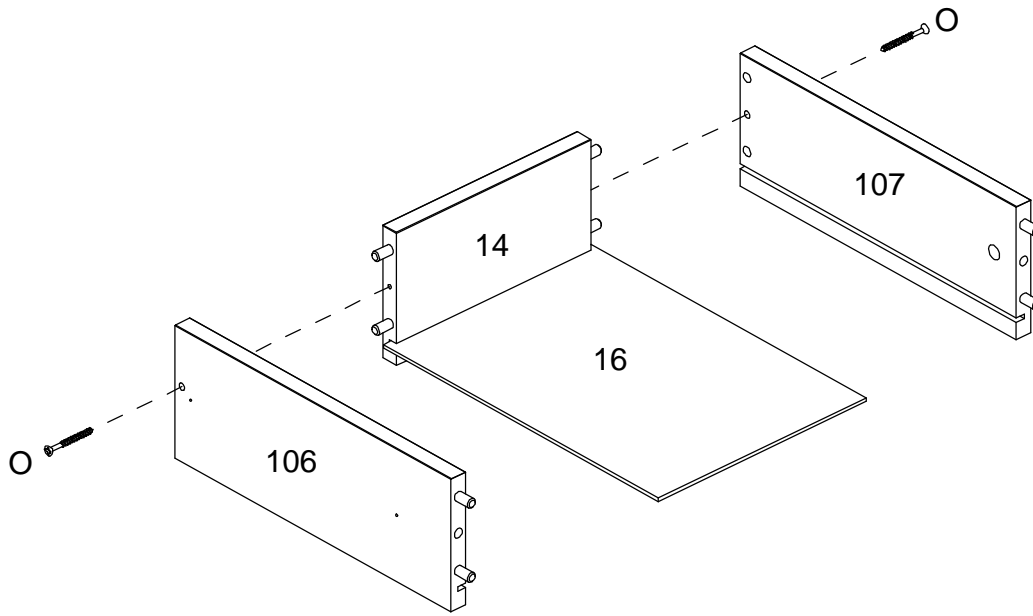

22

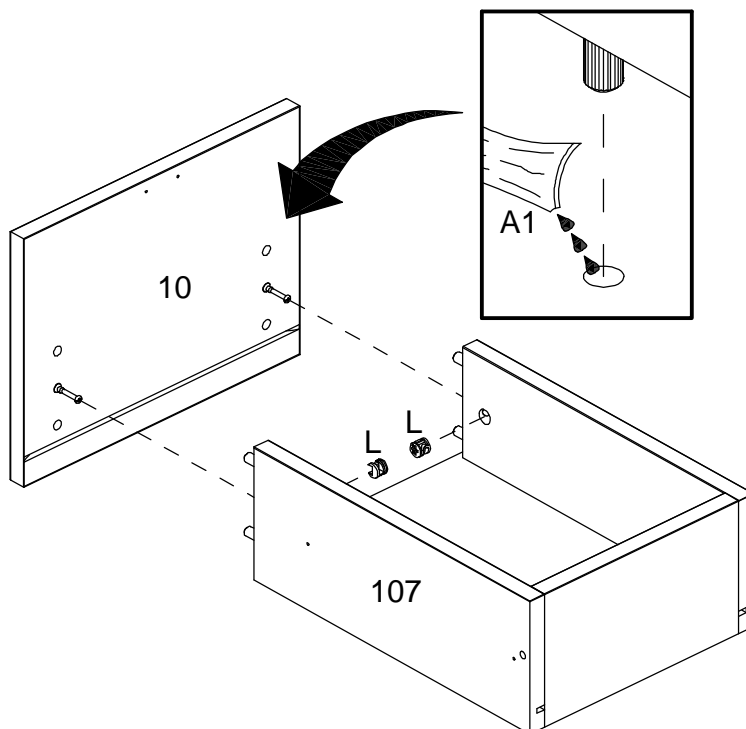

23

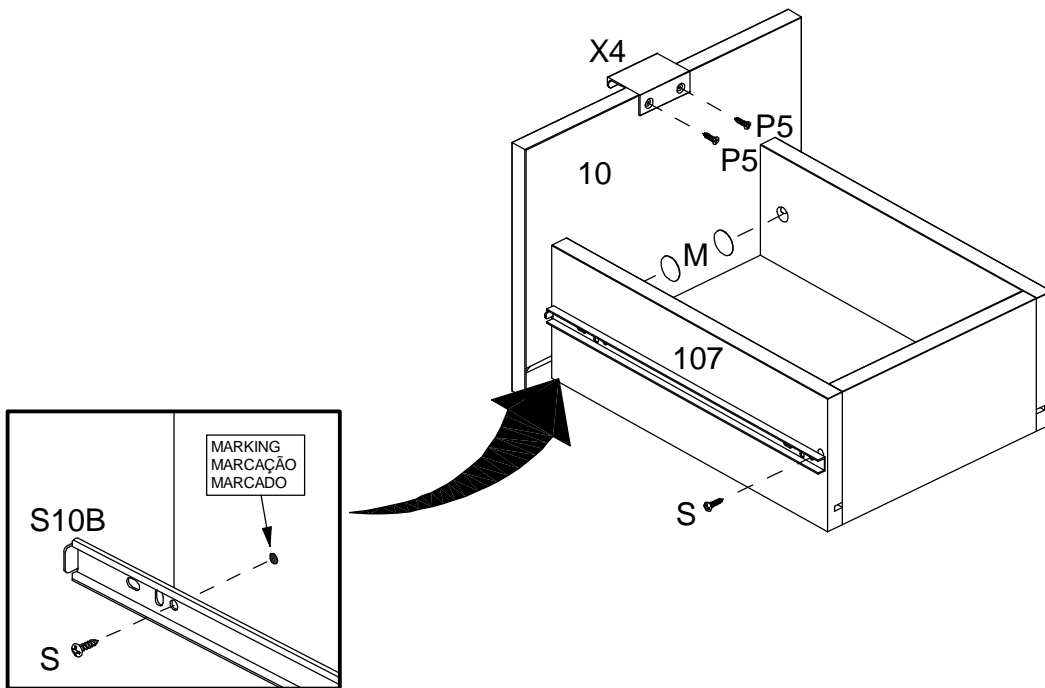

24

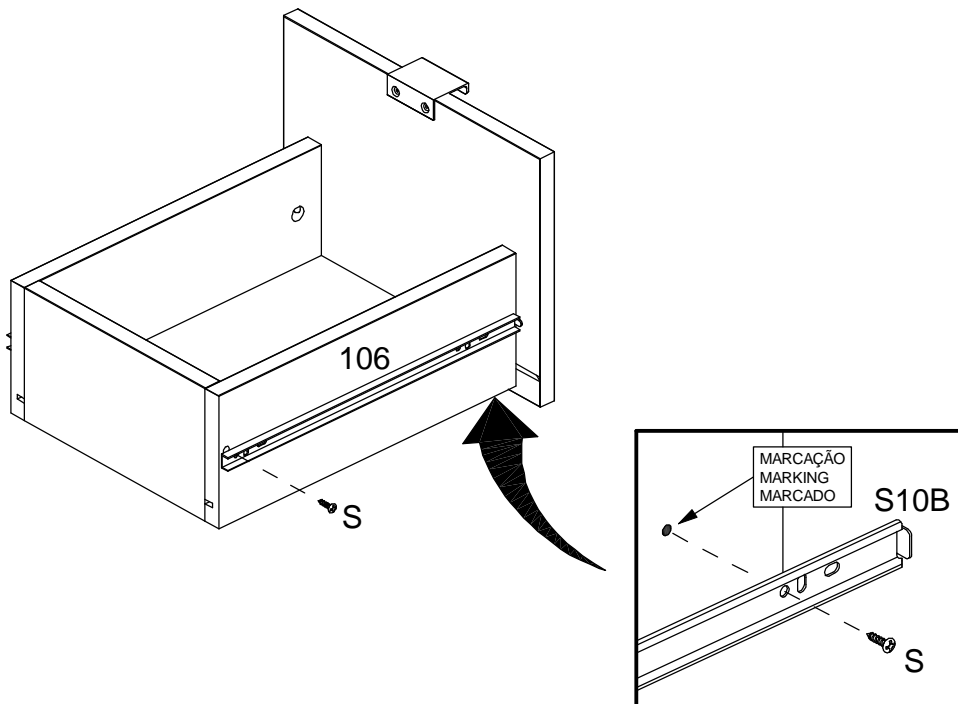

25

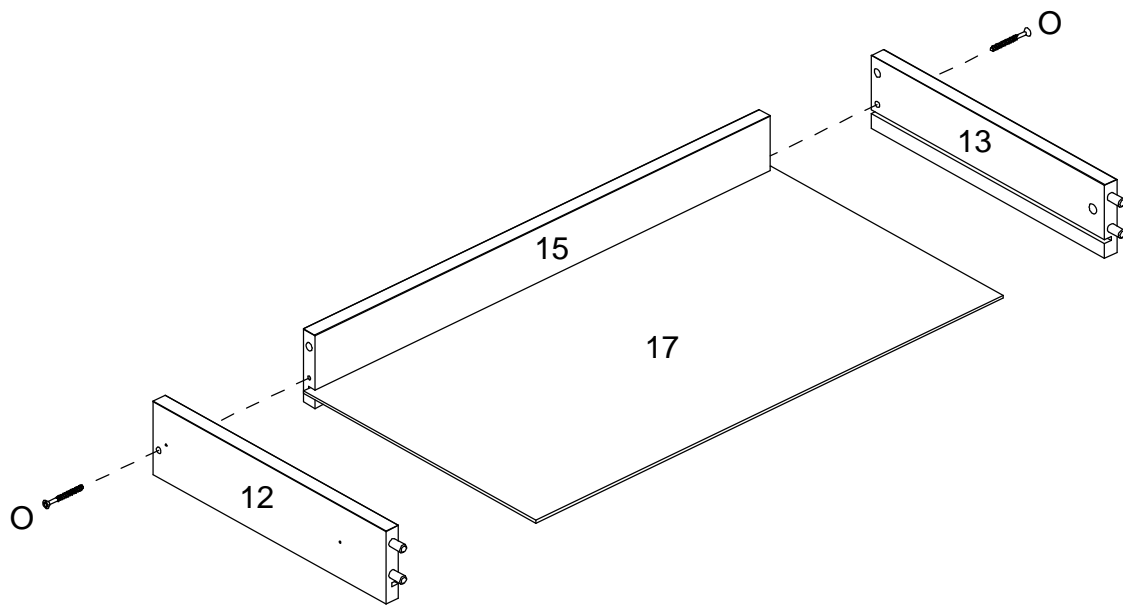

26

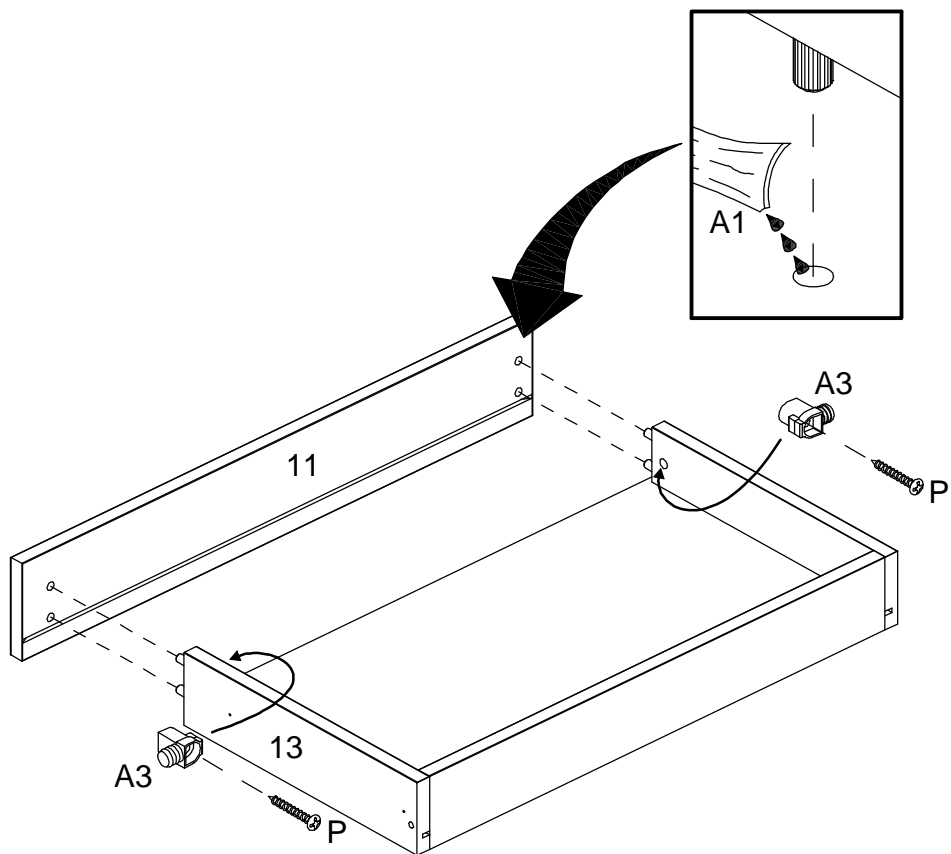

27

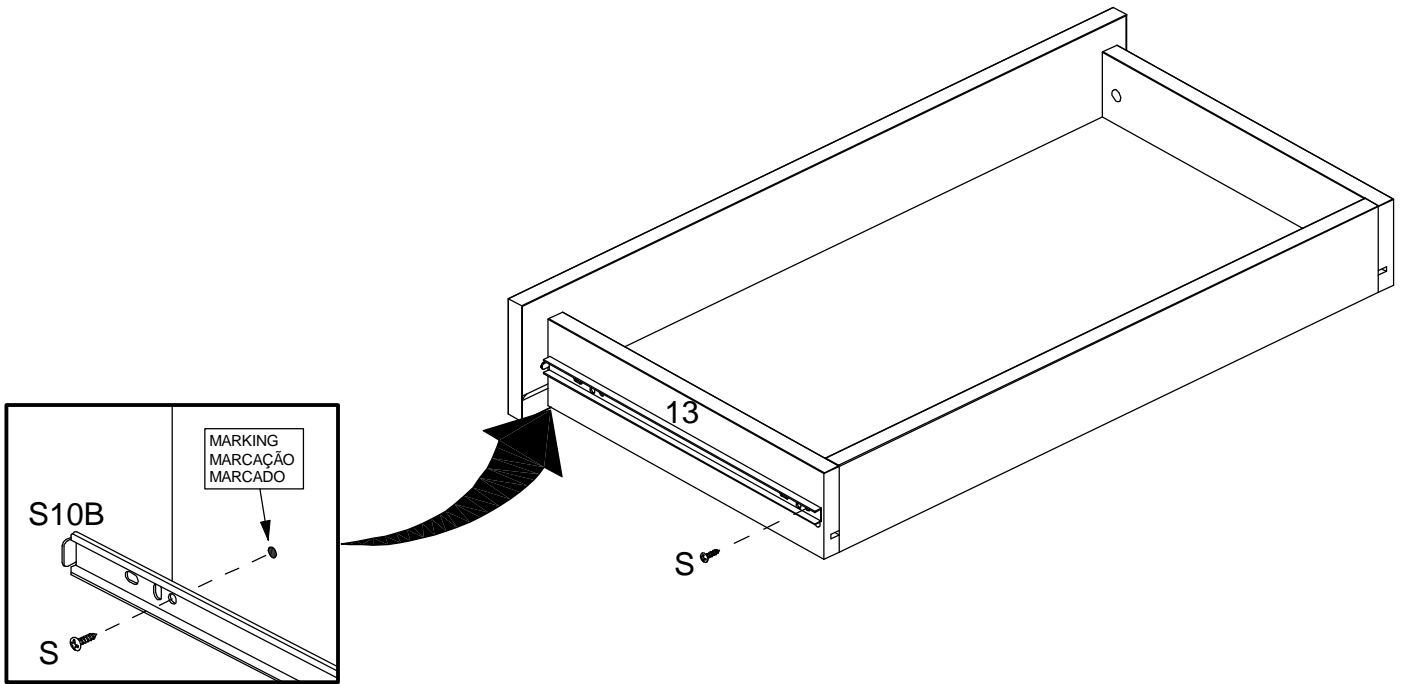

28

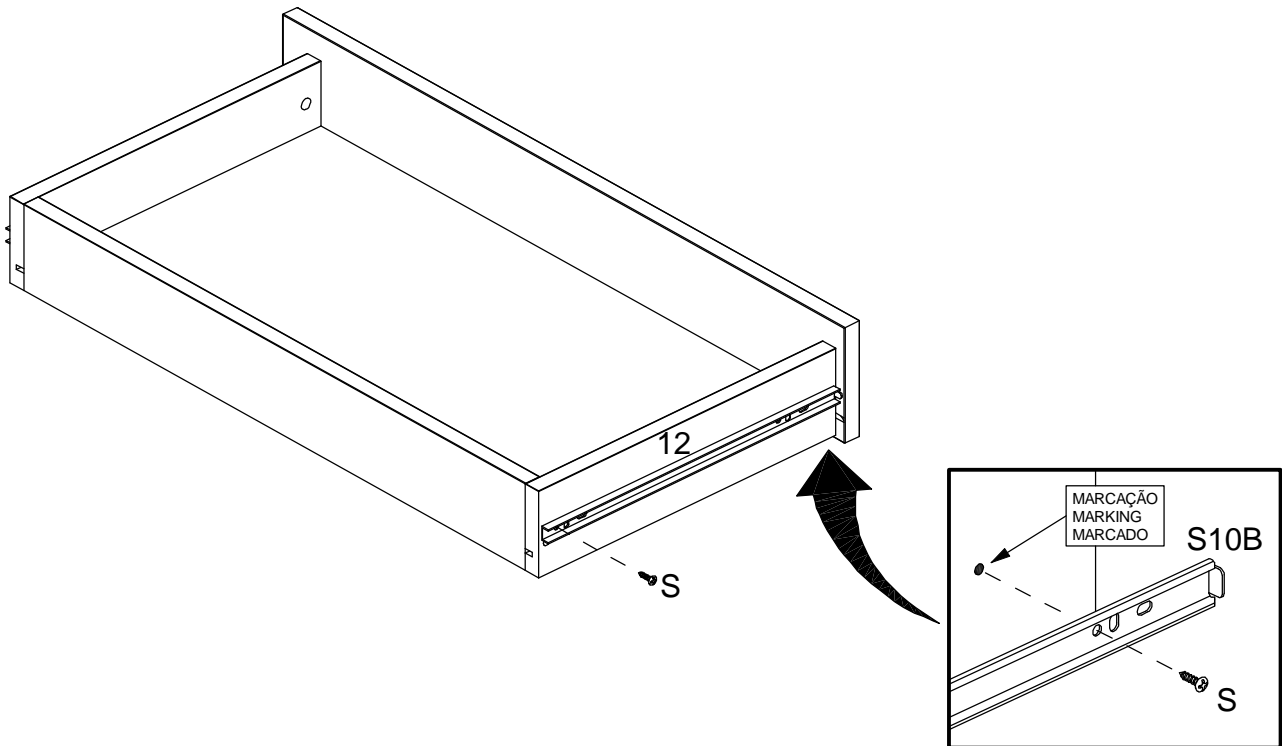

29

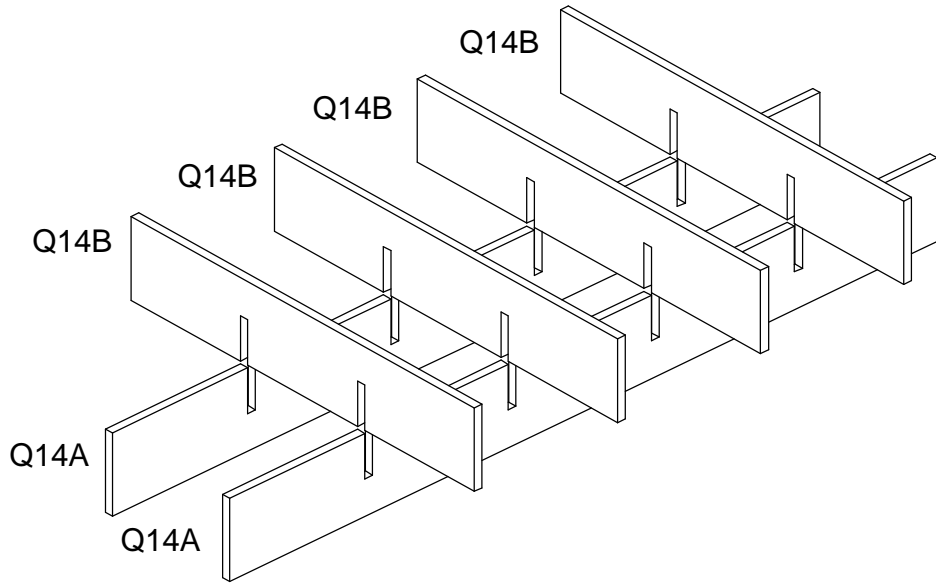

30

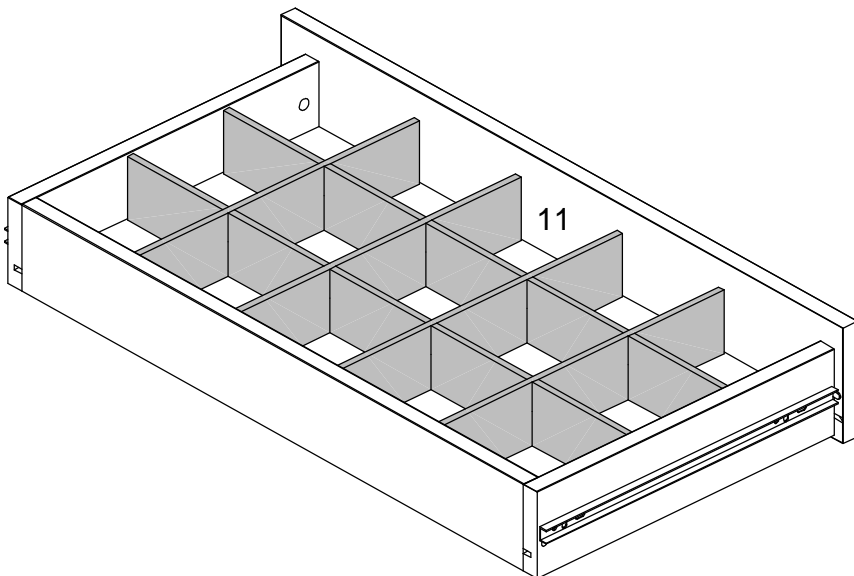

31

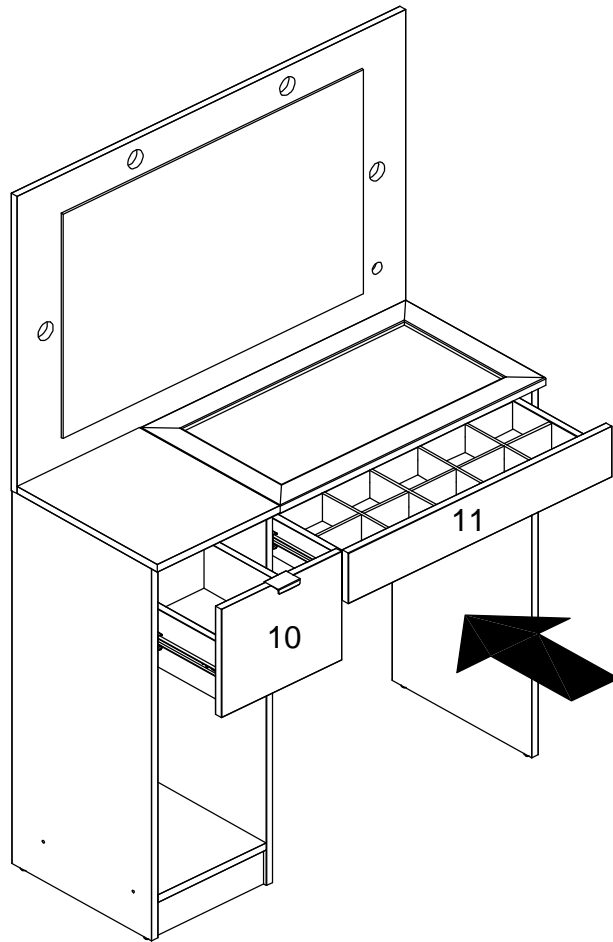

32

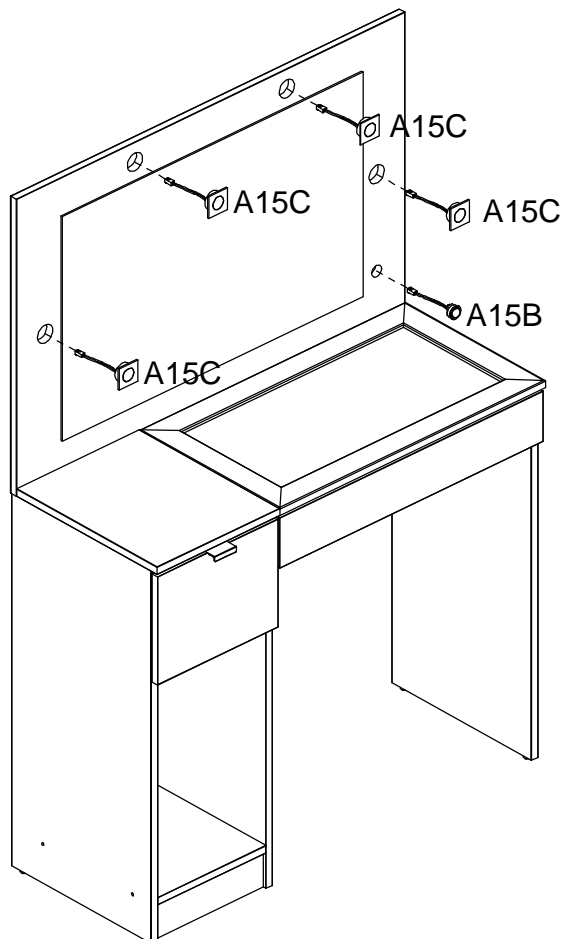

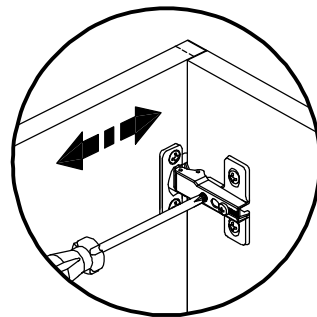
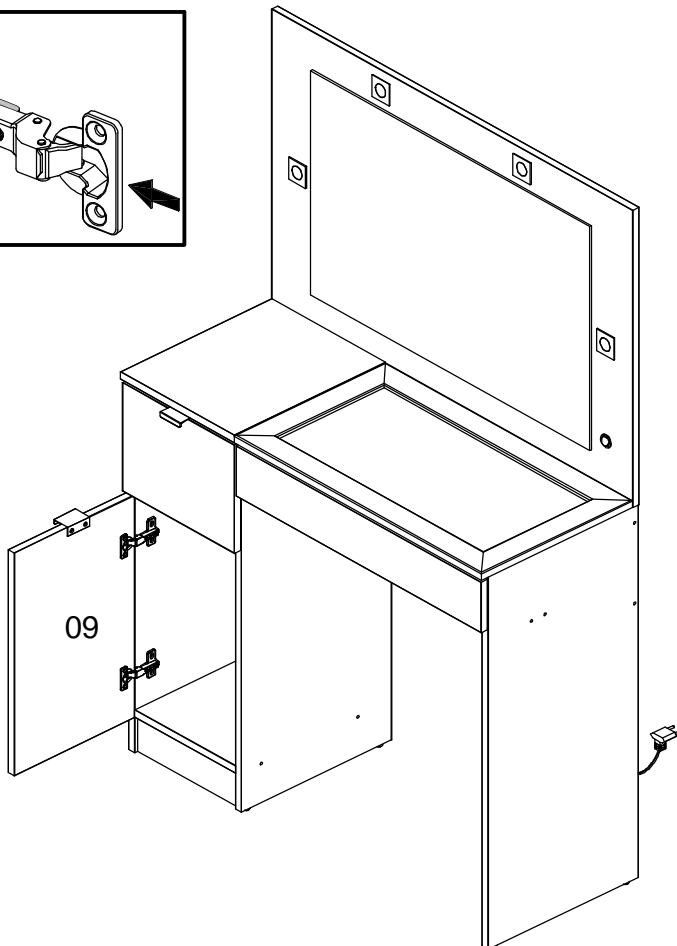
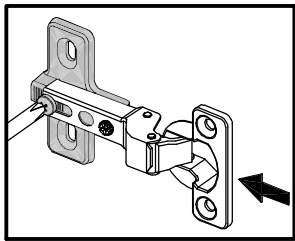
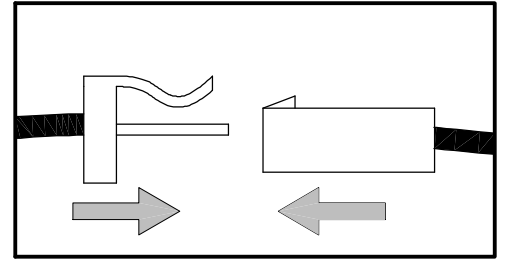
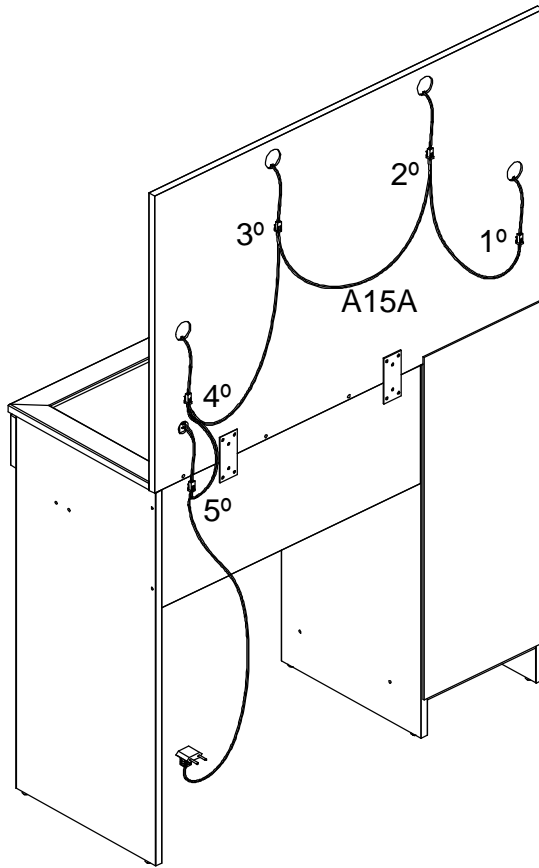

Horizontal Adjustment
Regulagem Horizontal
Ajuste Horizontal

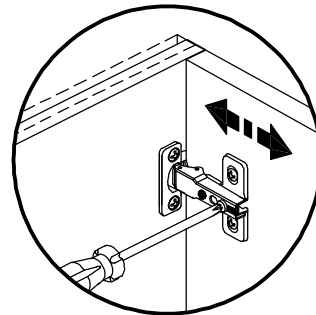

Depth Adjustment
Regulagem Profundidade
Ajuste Profundidad

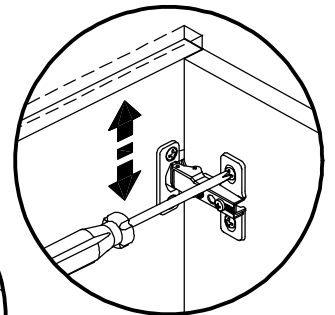

Vertical Adjustment
Regulagem Vertical
Ajuste Vertical