

# ASSEMBLY INSTRUCTIONS MANUAL DE MONTAGEM / INSTRUCCIONES DE ARMADO

SÃO PAULO MULTIUSE CABINET  
ARMÁRIO MULTIUSO SÃO PAULO  
ARMARIO MULTIUSO SÃO PAULO

Reference  
Referência  
Referencia **3080**

Revise  
Revisão  
Revisión **25**



## YOU WILL NEED / VOCÊ VAI PRECISAR DE / USTED NECESITARÁ

Tools not supplied / Ferramentas não fornecidas / Herramientas no incluidas

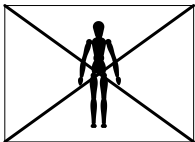

1 Person  
1 Pessoa  
1 Persona

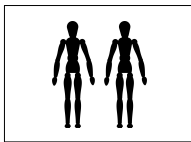

2 People  
2 Pessoas  
2 Personas

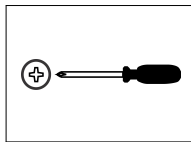

Screwdriver Phillips  
Chave Phillips  
Destornillador cruz

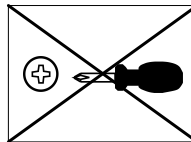

Small screwdriver Phillips  
Chave Phillips menor  
Destornillador cruz menor

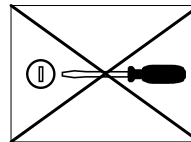

Screwdriver slotted  
Chave fenda  
Destornillador plano

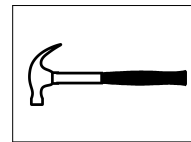

Hammer  
Martelo  
Martillo

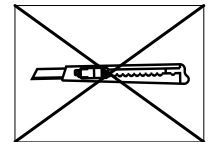

Stylet  
Estilete  
Estilete

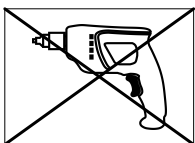

Drill machine  
Furadeira  
Taladro

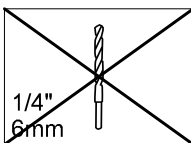

1/4"  
6mm  
Drill bit  
Broca  
Taladro

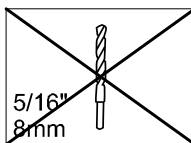

5/16"  
8mm  
Drill bit  
Broca  
Taladro

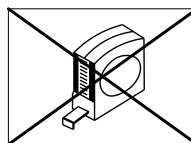

Measuring tape  
Trena  
Cinta de medición

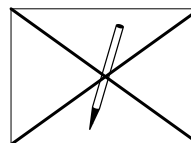

Pencil  
Lápis  
Lápiz

NOTES: The separation of the accessories before you start the assembly will facilitate the same. In case of doubt on the size of the screws and bolts, use the ruler to bottom of page 3.

NOTAS: A separação dos acessórios antes de iniciar a montagem facilitará a mesma. Em caso de dúvida no tamanho dos parafusos e cavilhas, utilize a régua ao final da página 3.

NOTAS: La separación de los accesorios antes de comenzar el armado facilitará el mismo. En caso de duda sobre el tamaño de los tornillos y taquetes, utilice la regla al pie de página 3.

MAXIMUM RECOMMENDED WEIGHT  
BEING THIS EVENLY DISTRIBUTED

PESO MÁXIMO RECOMENDADO SENDO  
ESTE DISTRIBUÍDO UNIFORMEMENTE

PESO MÁXIMO RECOMENDADO SIENDO  
ESTE UNIFORMEMENTE DISTRIBUIDO

_	LB	KG
B	4	2
F	22	10

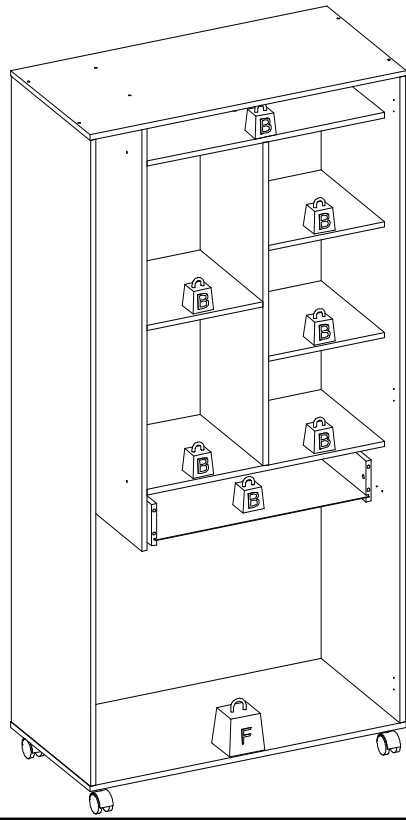





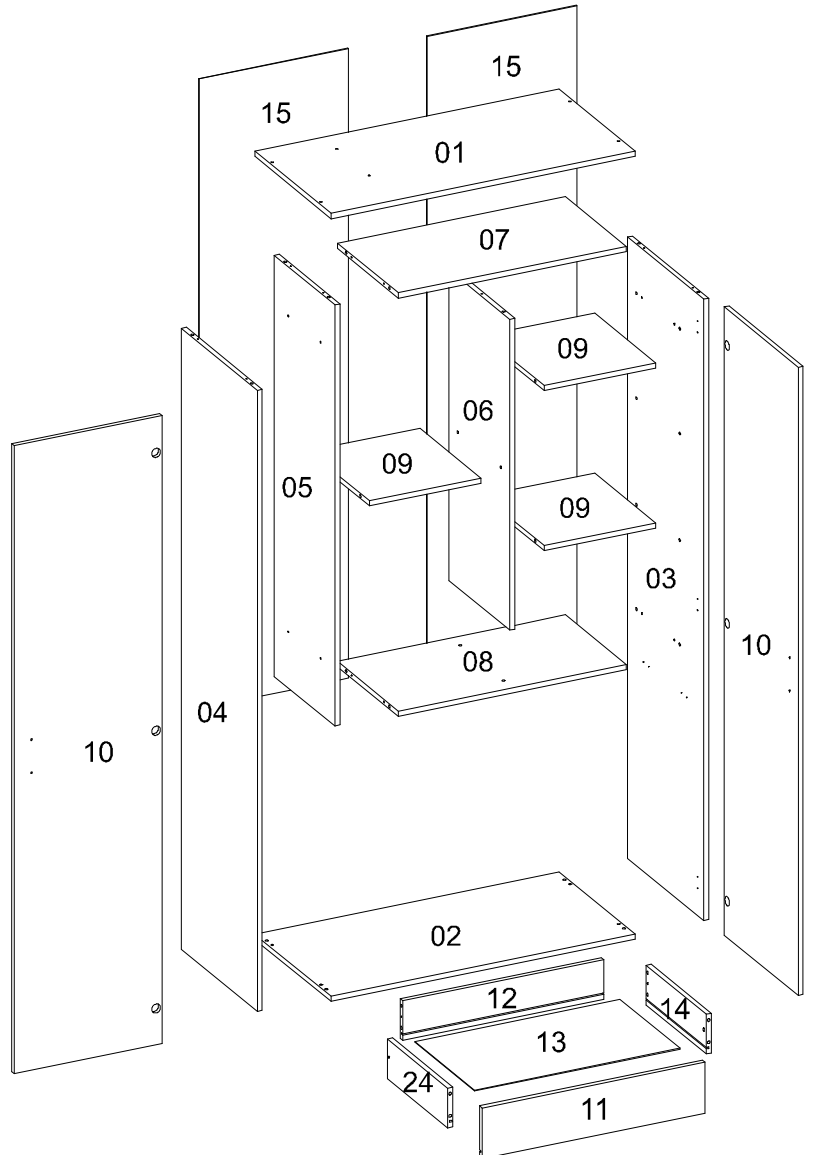







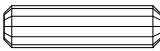

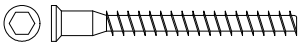

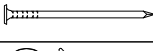
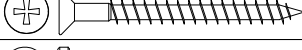
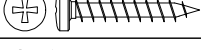

Nº	Measures_Inches	Medidas_cm	Qty./Qtd.
01	35 3/8 x 17 3/4 x 5/8	90.0 x 45.0 x 1.5	1
02	35 3/8 x 17 3/4 x 5/8	90.0 x 45.0 x 1.5	1
03	70 7/8 x 17 3/4 x 5/8	180.0 x 45.0 x 1.5	1
04	70 7/8 x 17 3/4 x 5/8	180.0 x 45.0 x 1.5	1
05	48 x 14 1/8 x 5/8	122.0 x 36.0 x 1.5	1
06	35 1/2 x 14 1/8 x 5/8	90.1 x 36.0 x 1.5	1
07	26 5/8 x 14 1/8 x 5/8	67.5 x 36.0 x 1.5	1
08	26 5/8 x 14 1/8 x 5/8	67.5 x 36.0 x 1.5	1
09	13 x 14 1/8 x 5/8	33.0 x 36.0 x 1.5	3
10	71 5/8 x 17 1/4 x 5/8	182.0 x 43.7 x 1.5	2
11	26 x 5 3/4 x 5/8	66.0 x 14.7 x 1.5	1
12	23 3/8 x 4 1/2 x 5/8	59.5 x 11.5 x 1.5	1
13	23 7/8 x 13 7/8 x 1/8	60.7 x 35.4 x 0.3	1
14	14 x 4 1/2 x 5/8	35.5 x 11.5 x 1.5	1
15	71 3/4 x 17 3/8 x 1/8	182.4 x 44.2 x 0.3	2
24	14 x 4 1/2 x 5/8	35.5 x 11.5 x 1.5	1
-	x x	x x	1

### PARTS IDENTIFICATION IDENTIFICAÇÃO DAS PEÇAS / IDENTIFICACIÓN DE LAS PIEZAS

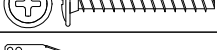

## IDENTIFICATION OF ACCESSORIES IDENTIFICAÇÃO DOS ACESSÓRIOS/ IDENTIFICACIÓN DE ACCESORIOS

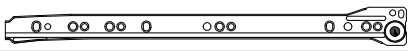
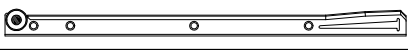
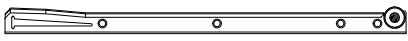
A1		Glue / Cola / Pegamento	13 g	1
A3		Trapeze / Trapézio / Trapecio	-	2
A6		"H" profile / Perfil "H" / Perfil "H"	-	1
C2		Handle / Puxador Partenon / Tirador	96 mm	2
D5		Hinge shim / Calço dobradiça / Bisagra de calce	-	6
E		Wooden dowel / Cavilha / Taquete	8x30 mm	42
F6		Metal hinge curve / Dobradiça curva / Esquina de bisagra metálica	26 mm	6
G		Structural screw / Parafuso estrutural / Tornillo estructural	5,0x50 mm	8
G7		Small hanger support/ Suporte cabide pequeno/ Soporte cabida pequeño	-	2
H		Allen key / Chave allen / Liave allen	3 mm	1
I		Structural screw cover/Tampa parafuso estrutural/Tapa tornillo estructural	-	8
K1		Double support / Suporte duplo / Soporte doble	-	1
K5A		Caster / Rodízio 50 / Rueda	-	4
N		Nail / Pregos / Clavo	10x10	58
O		Flat head screw / Parafuso chato / Tornillo de cabeza plana	4,5x45 mm	14
P		Pan head screw / Parafuso panela / Tornillo de pan	4,5x25 mm	2
P5		Flat head screw / Parafuso chato especial / Tornillo de cabeza plana	3,5x14 mm	8
R2		Spacer slide / Distanciador de corrediça / Espaciador de corrediza	25 mm	2
S		Pan head screw / Parafuso panela / Tornillo de pan	3,5x14 mm	48
T		Flanged head screw / Parafuso flangeado / Tornillo de cabeza flangeada	3,5x25 mm	4
VA		Metallic slide the left field / Corrediça lateral esquerda / Corredera lateral izquierda	350 mm	1
VB		Metallic slide the right field / Corrediça lateral direita / Corredera lateral derecha	350 mm	1
VC		Drawer slide left / Corrediça gaveta esquerda / Corredera izquierda cajón	350 mm	1
VD		Drawer slide right / Corrediça gaveta direita / Corredera derecha cajón	350 mm	1



PRE-ASSEMBLE  
PRÉ-MONTAGE / PRE ARMADO

01

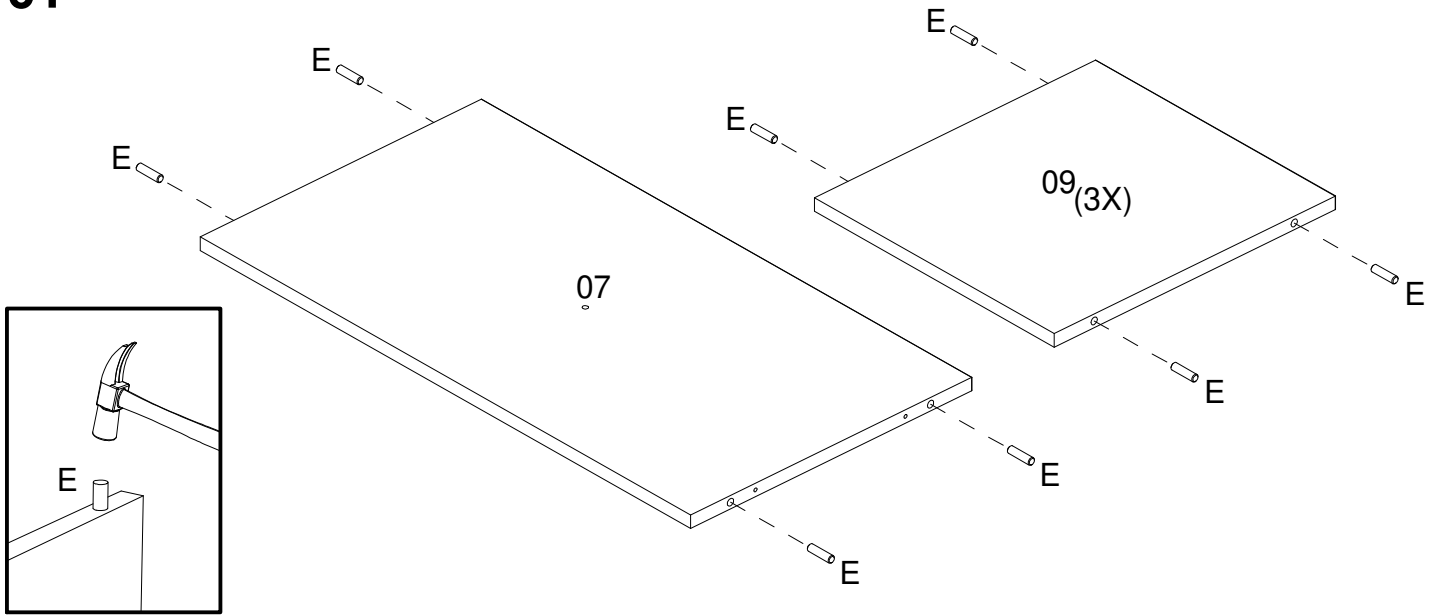

02

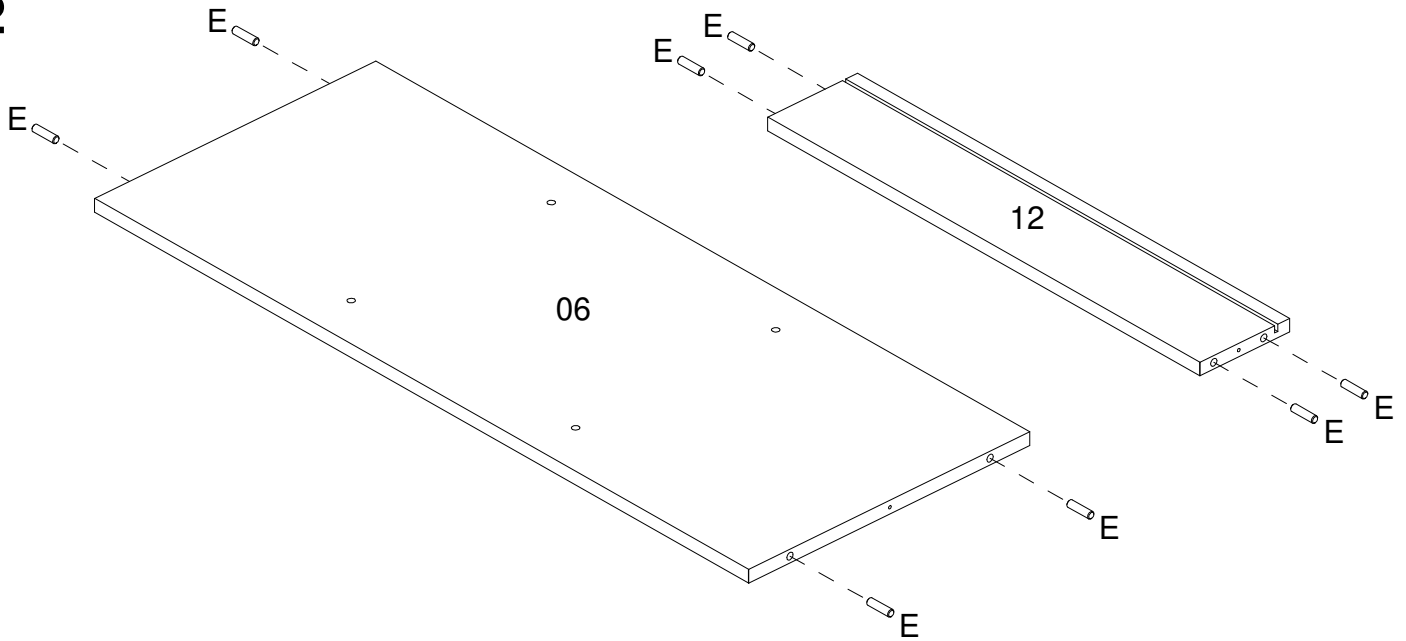

03

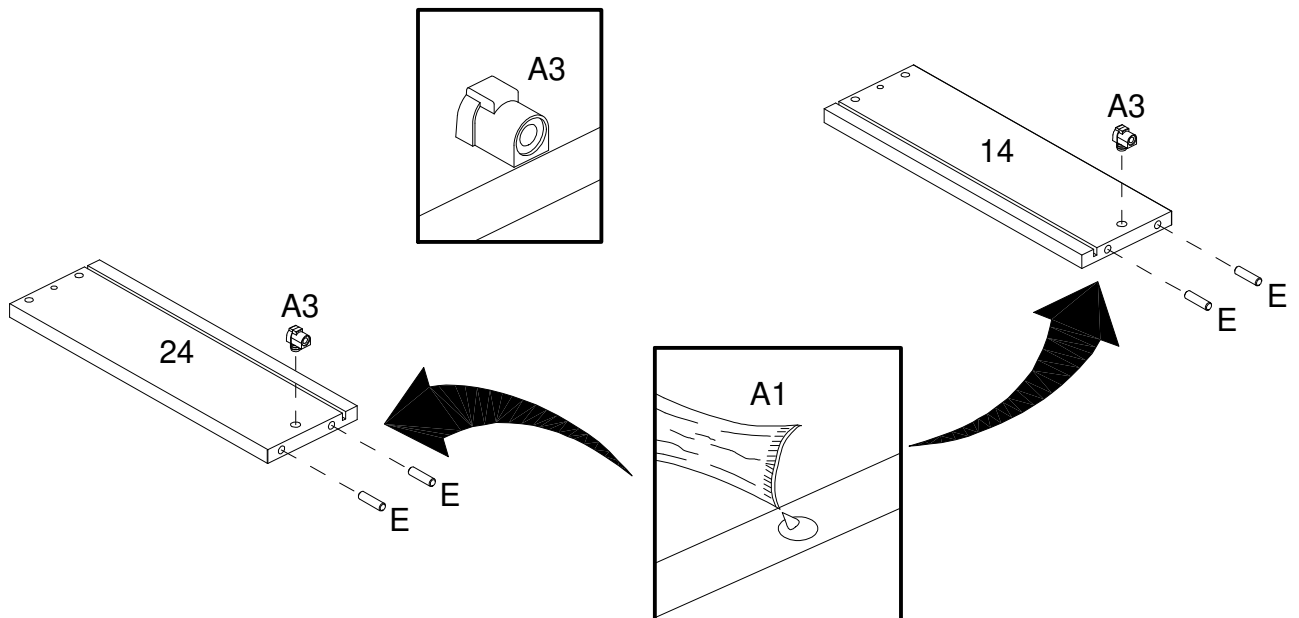

04

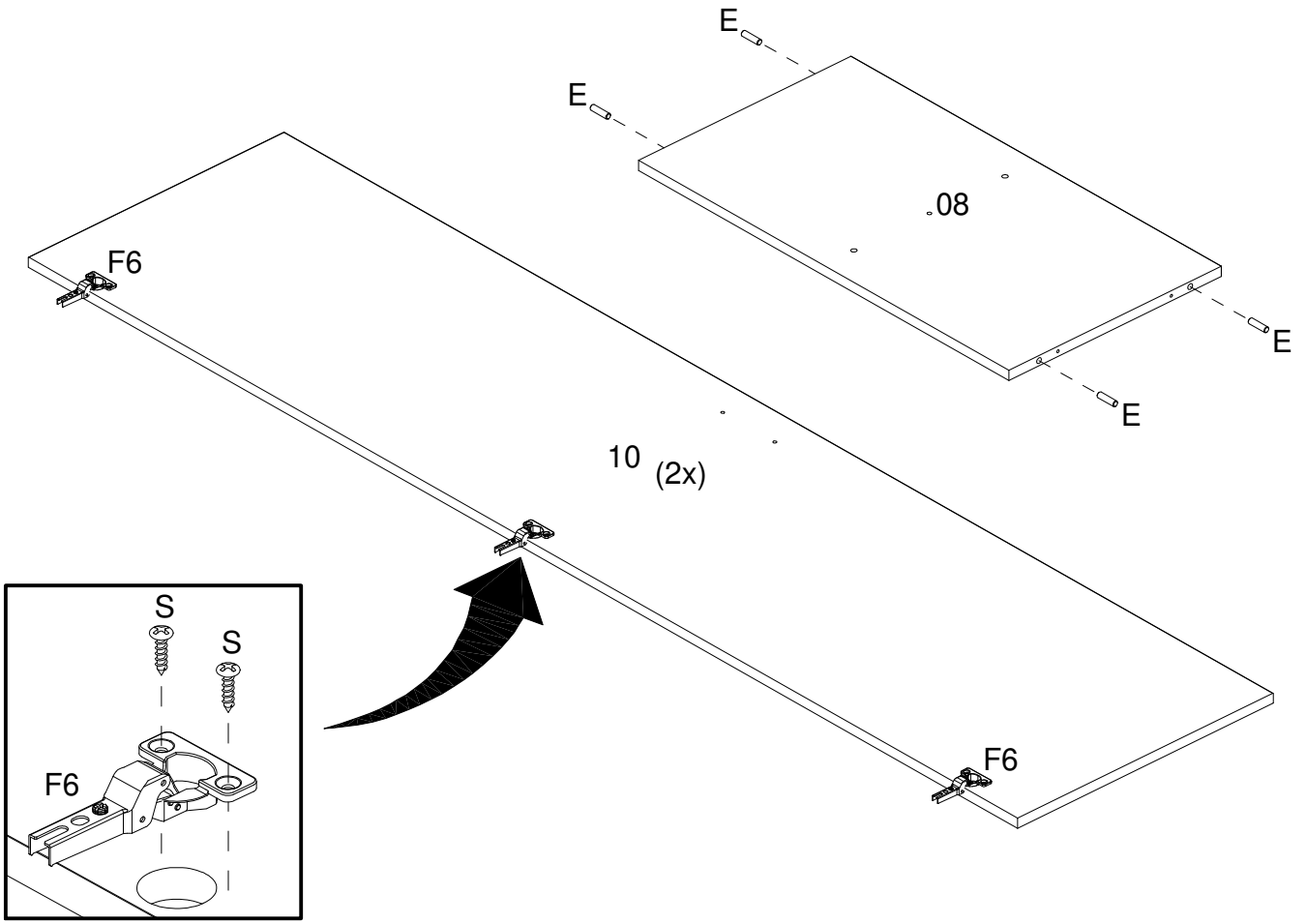

05

Choose the position of your choice!  
Escolha a posição de sua preferência!  
¡Elige la posición de tu elección!

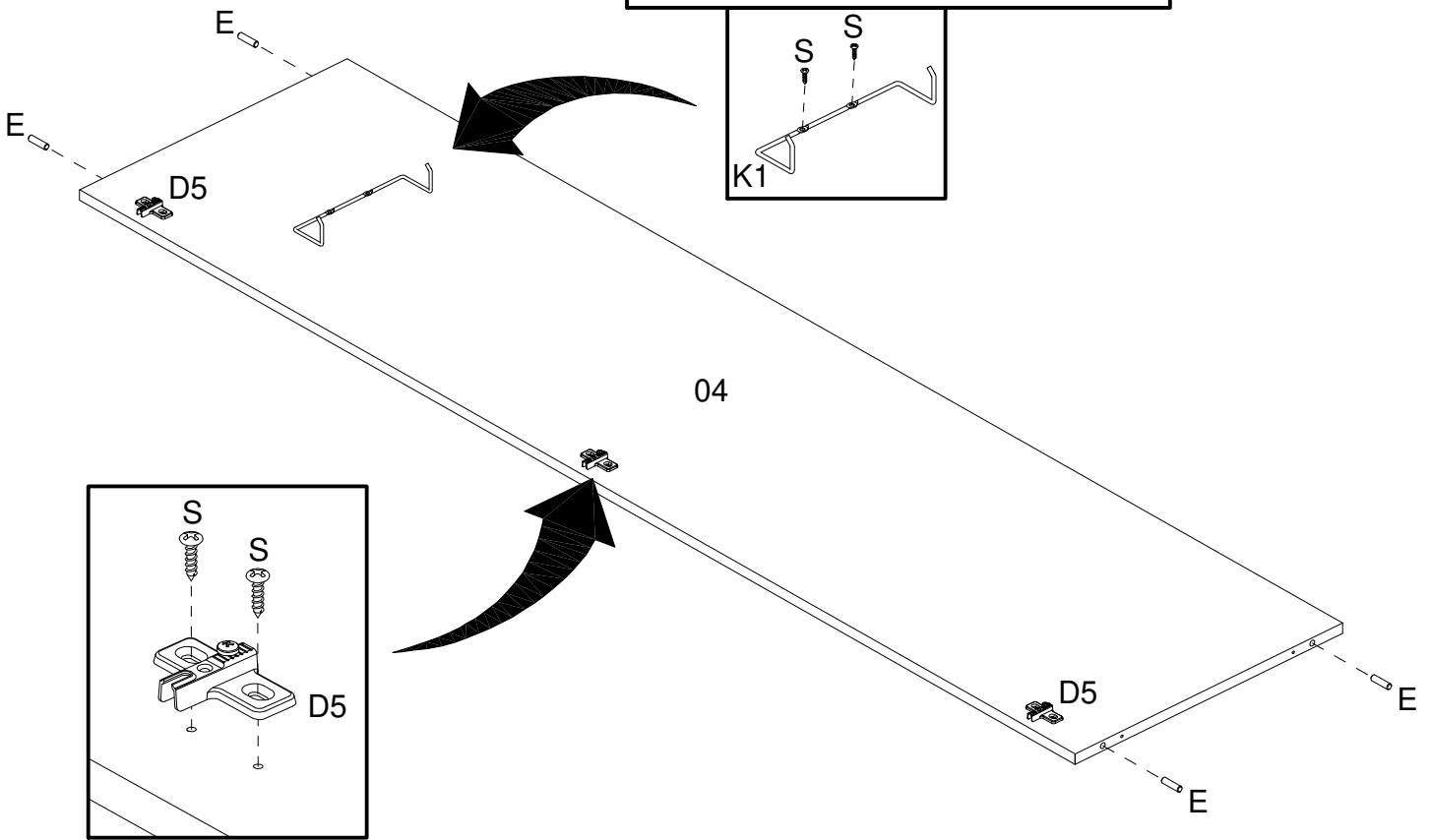

06

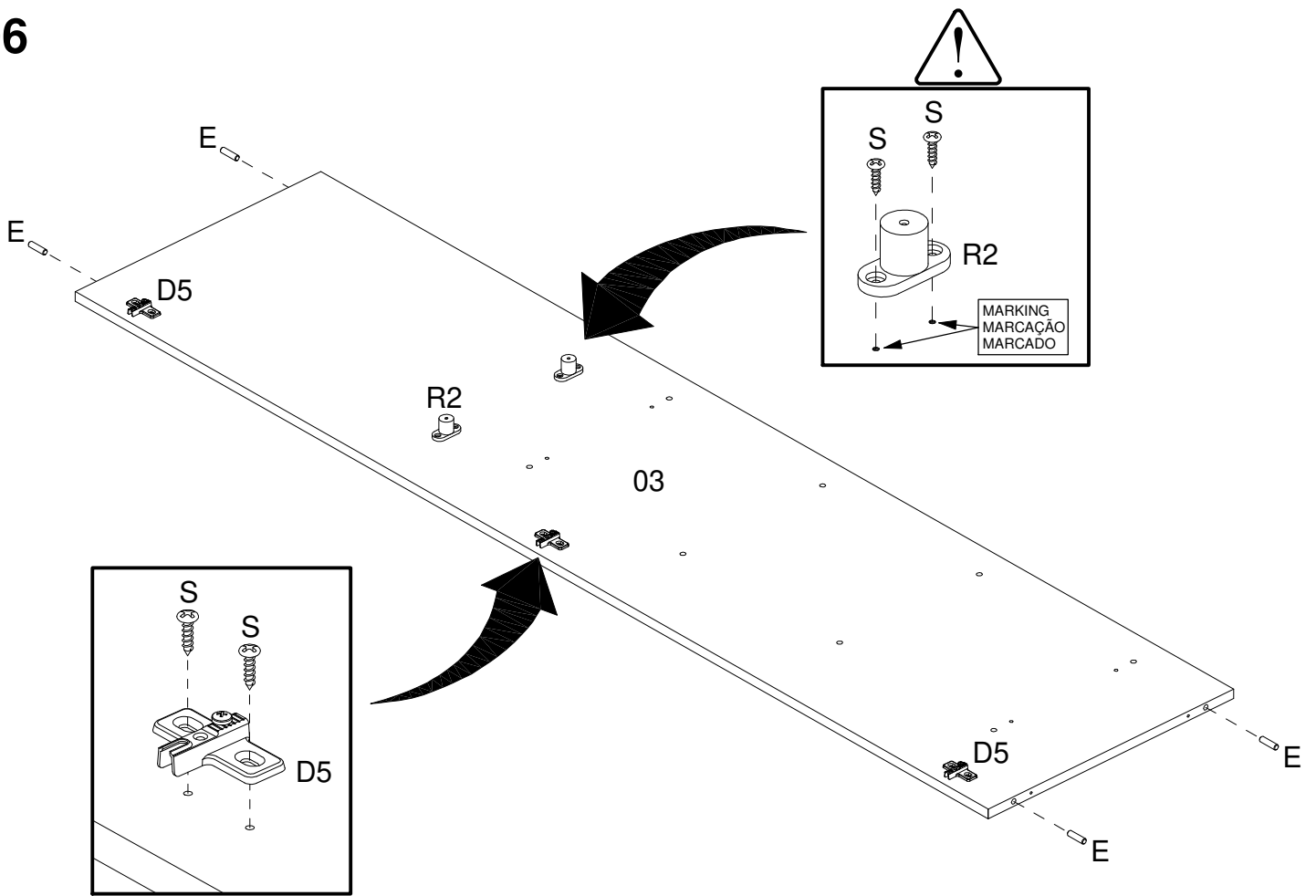

07

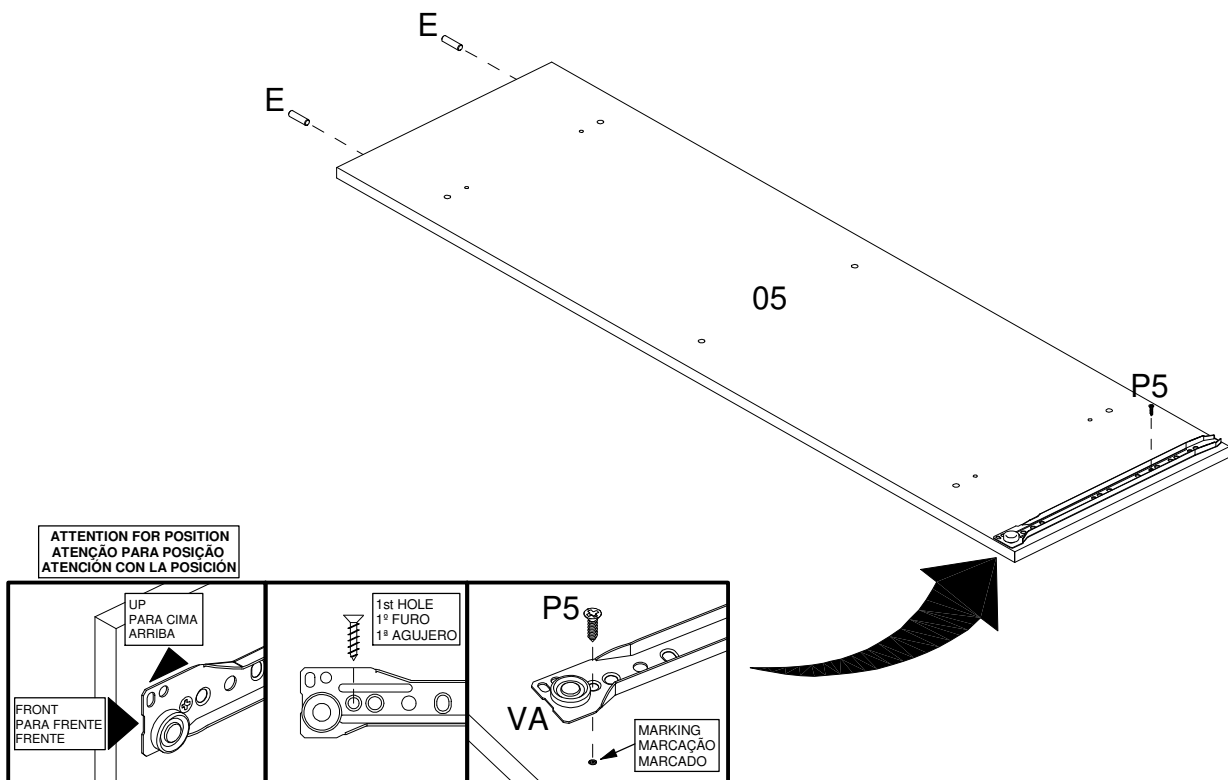

**ASSEMBLY  
MONTAGEM / ARMADO**

**08**

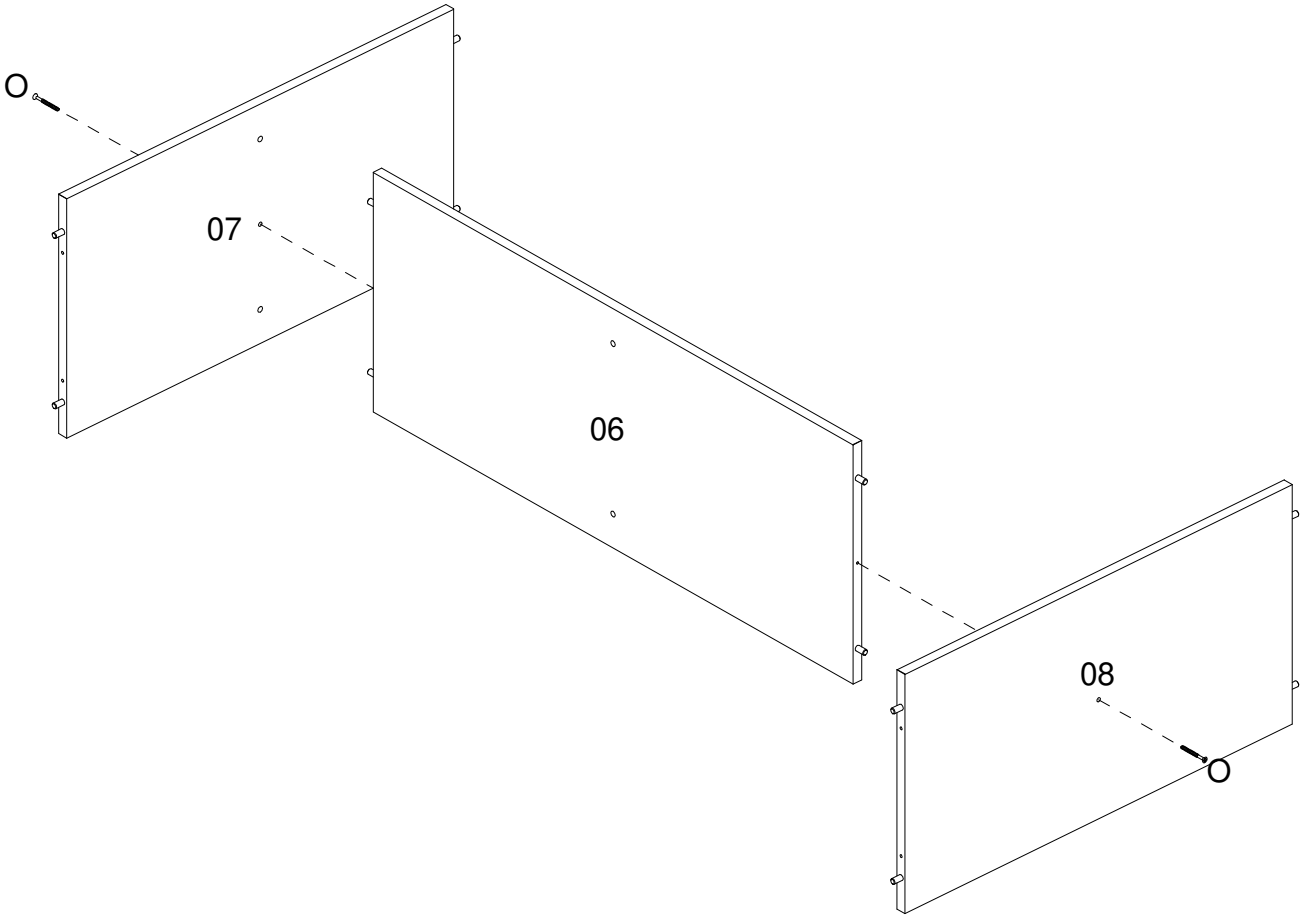

**09**

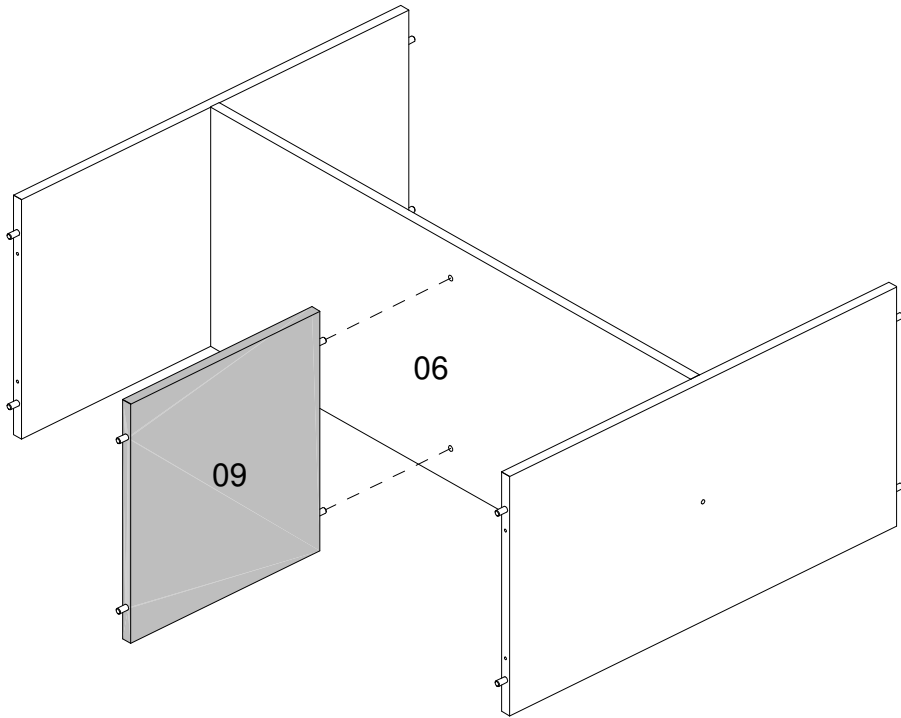

10

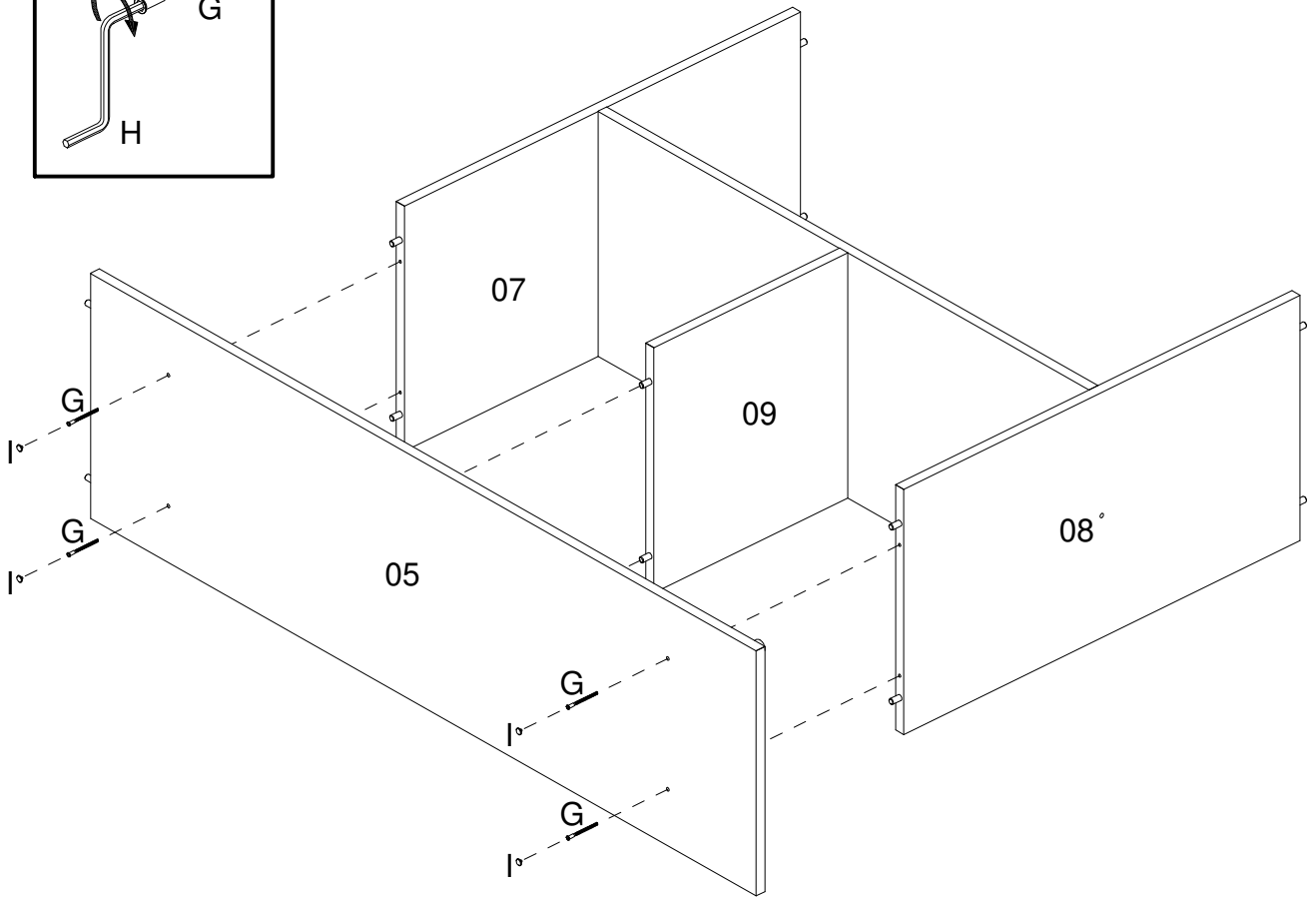
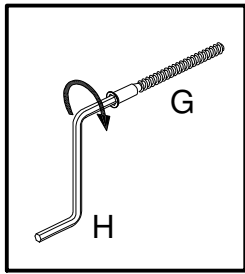

11

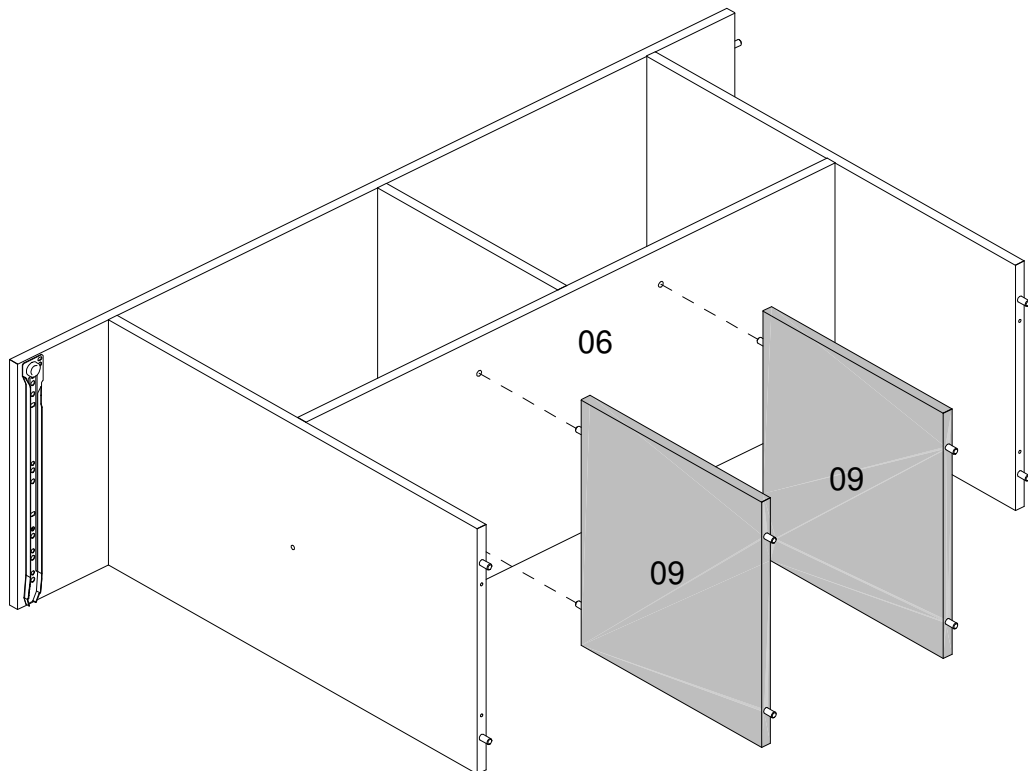



12

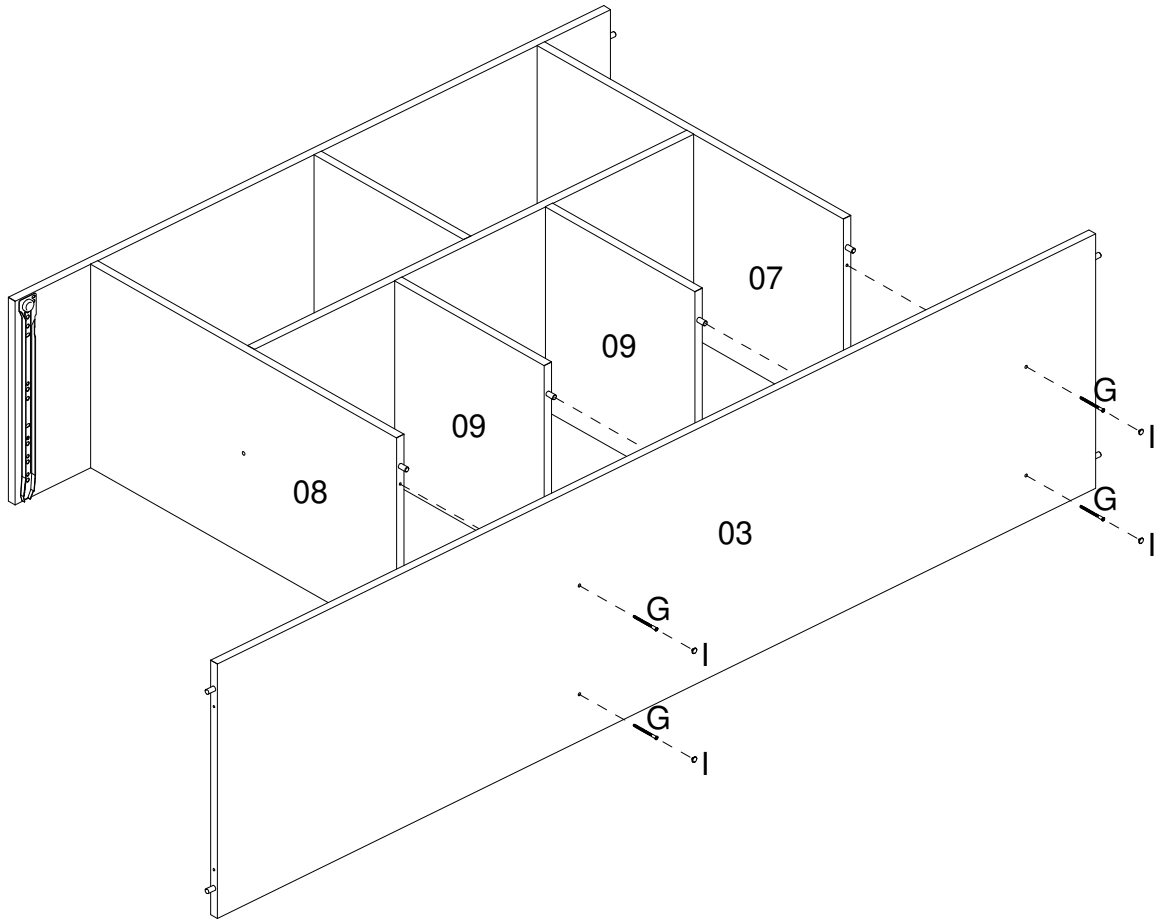

13

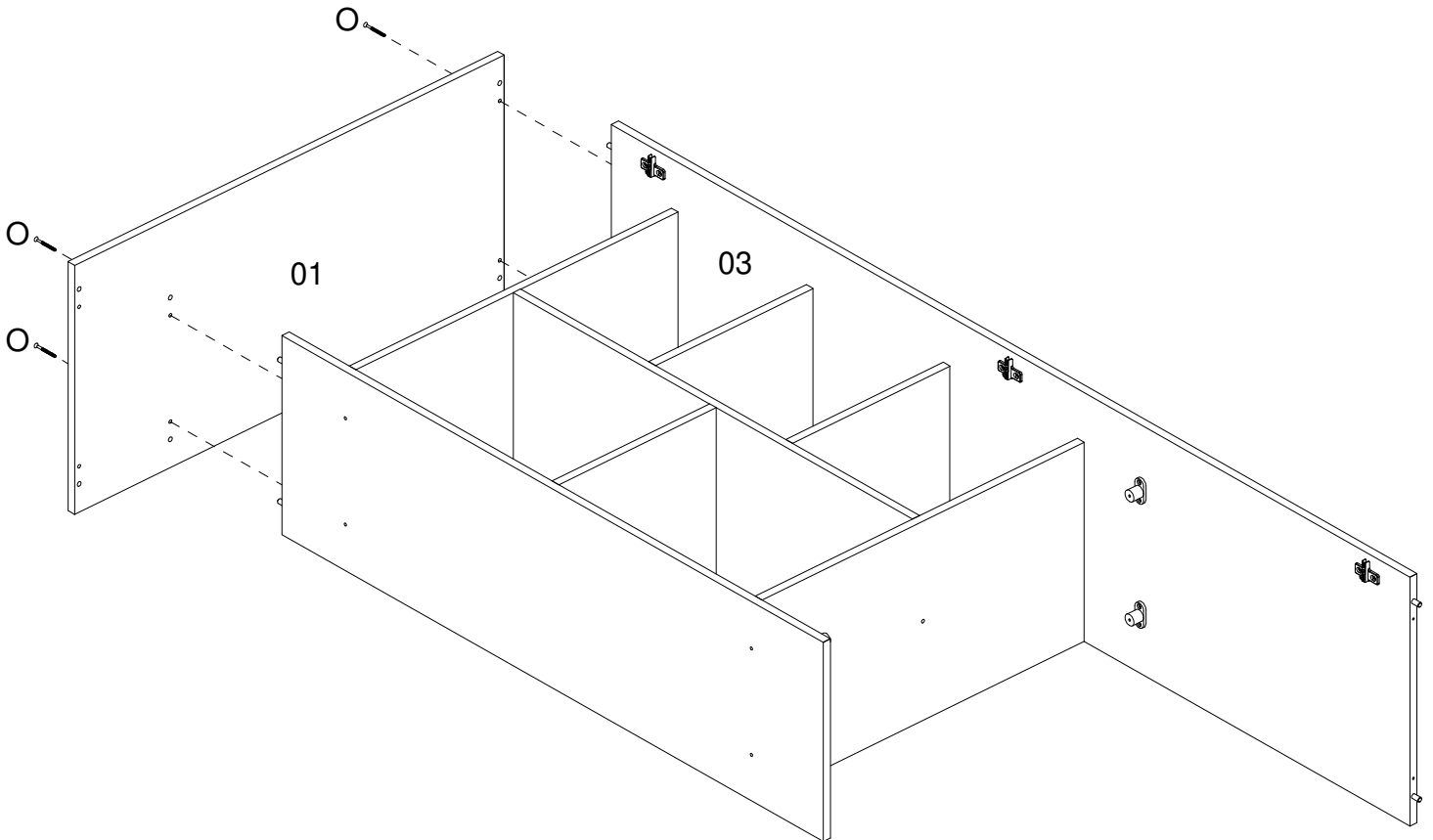

14

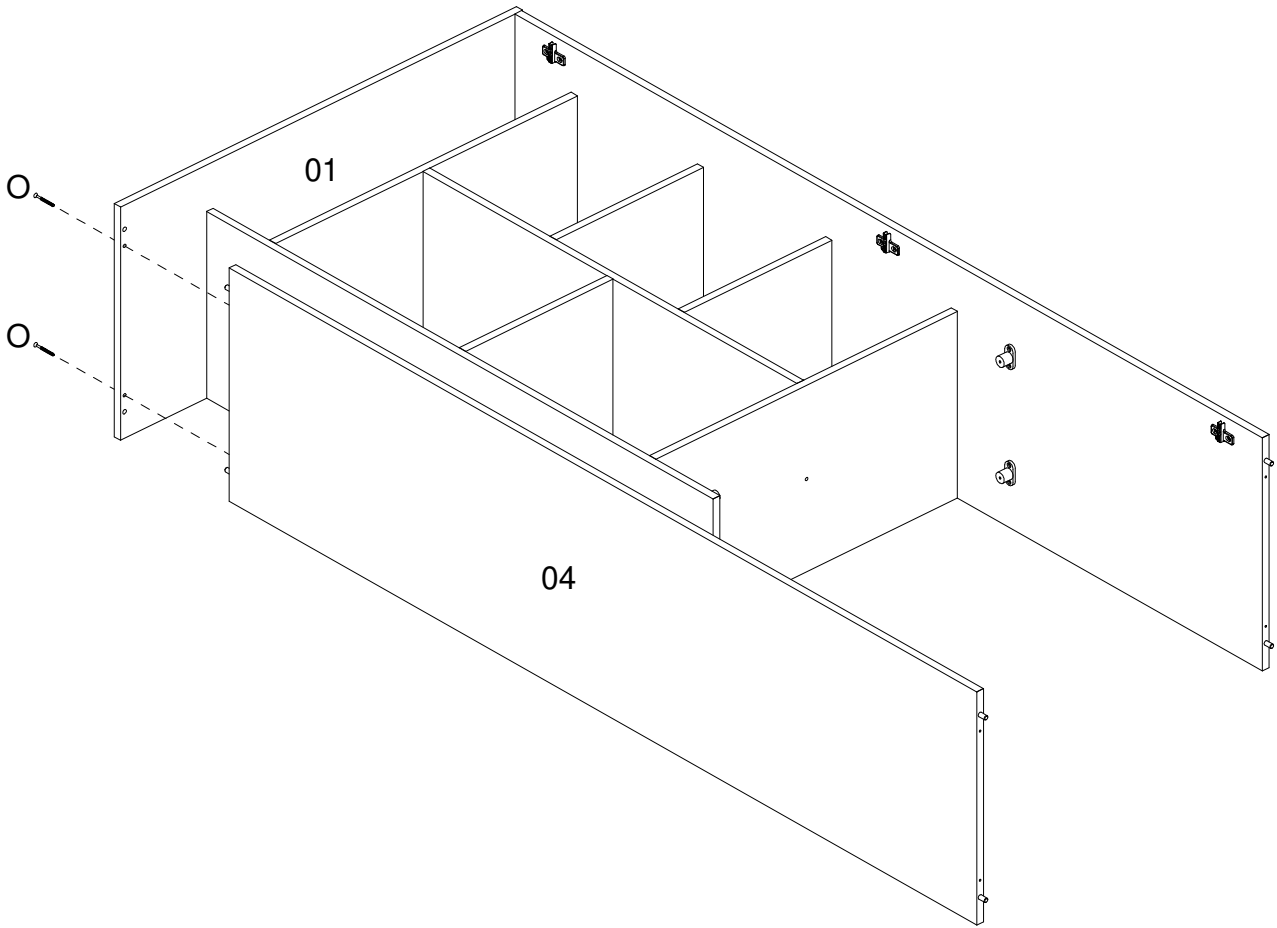

15

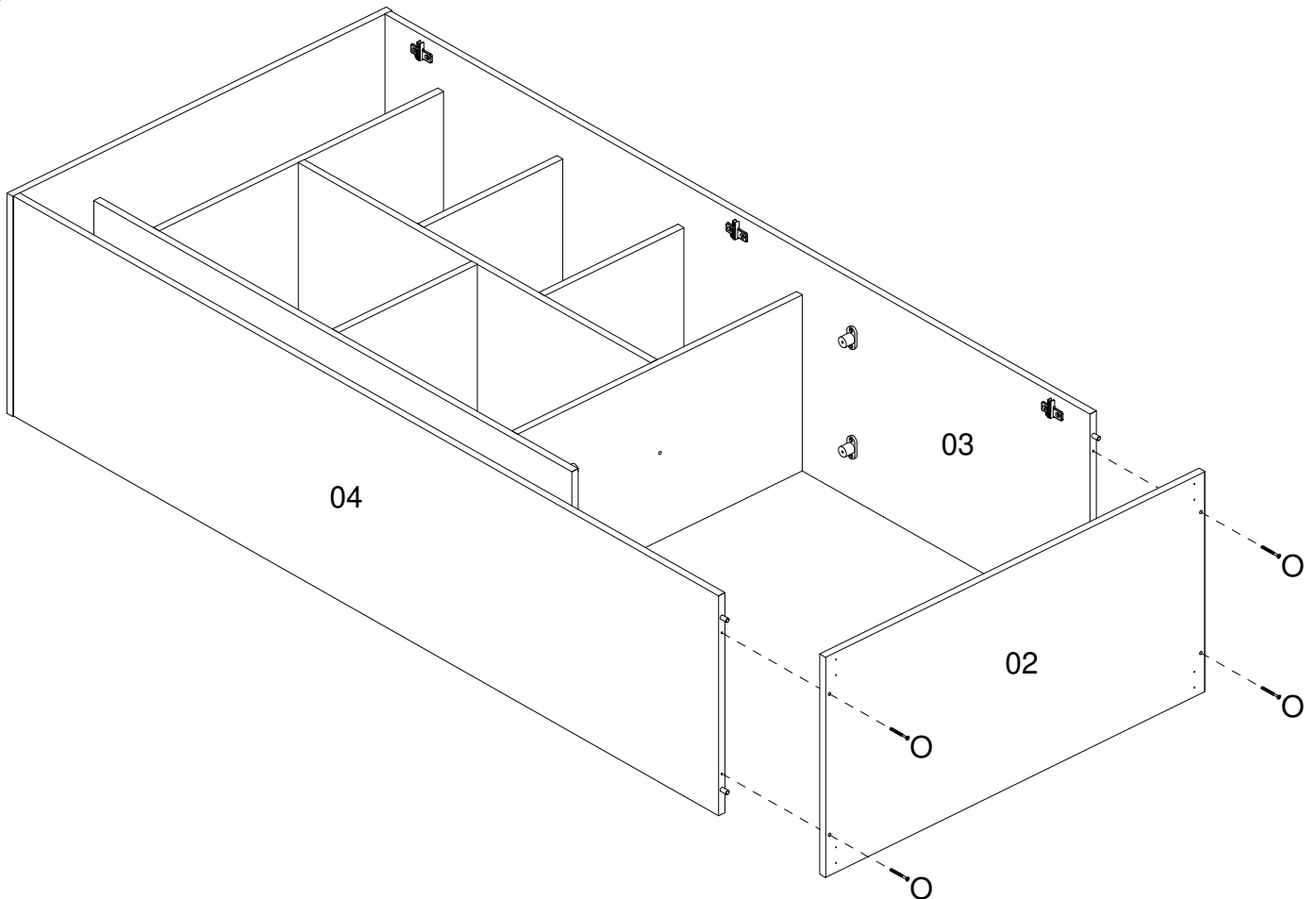

16

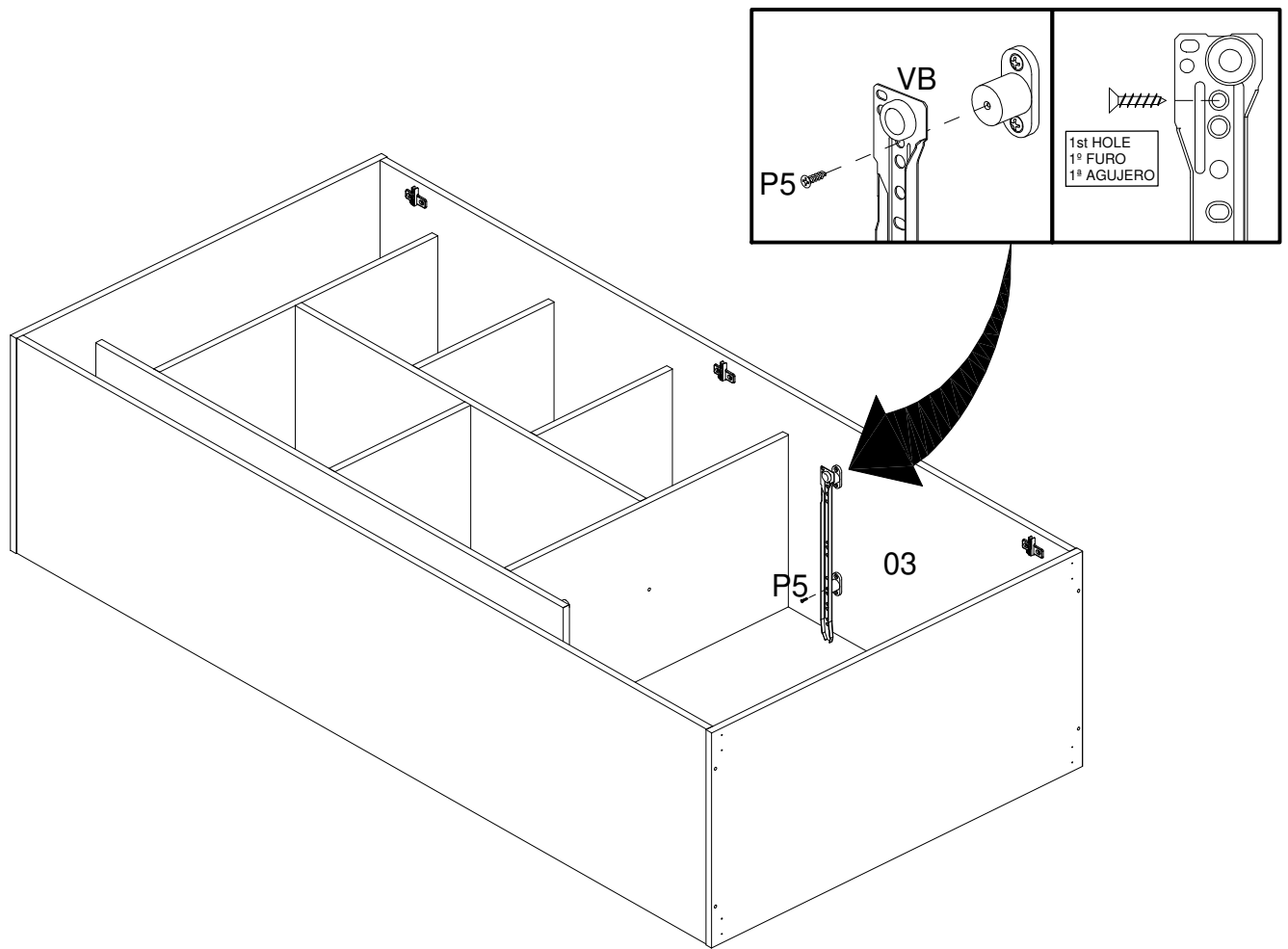

17

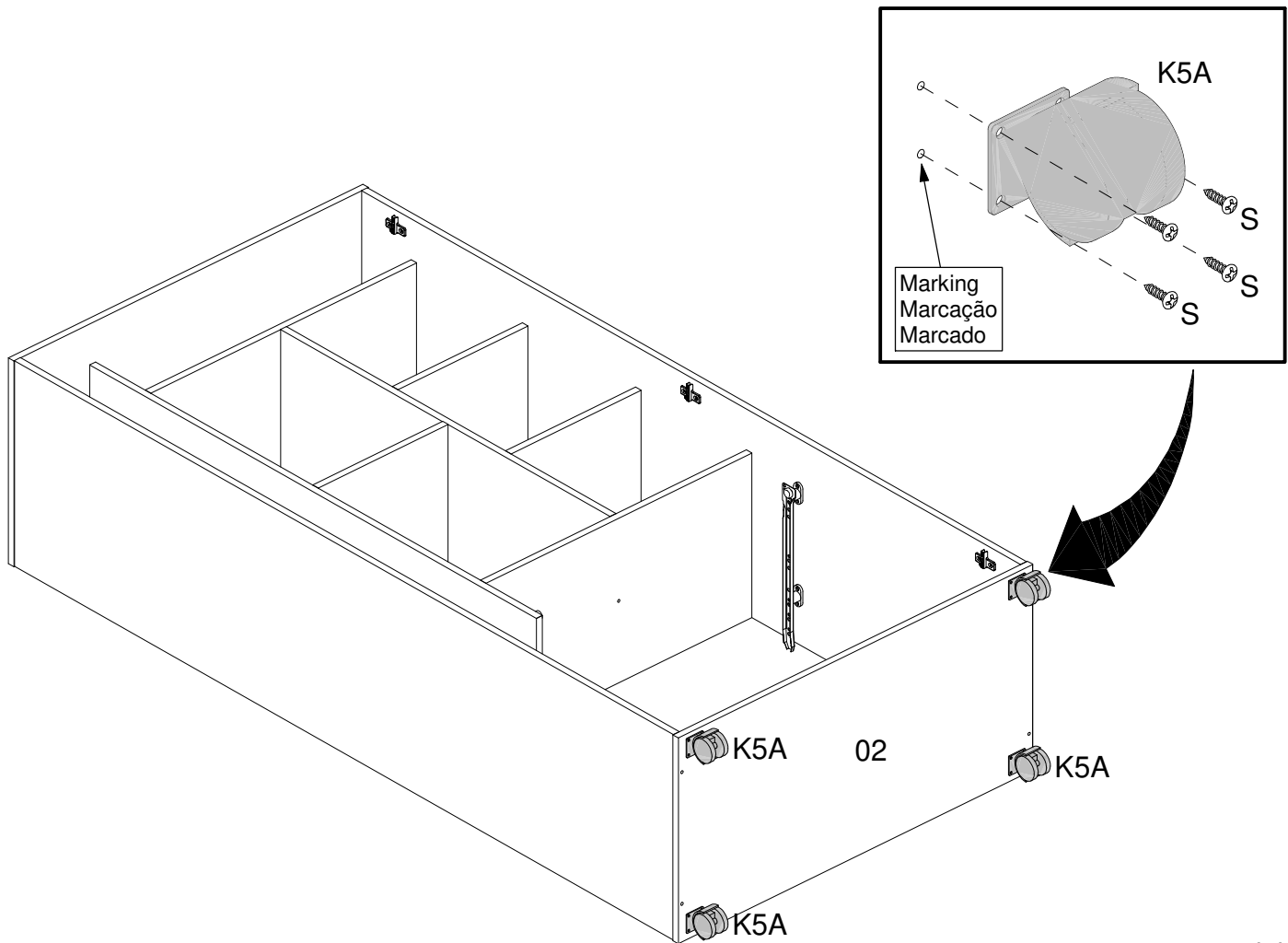

18

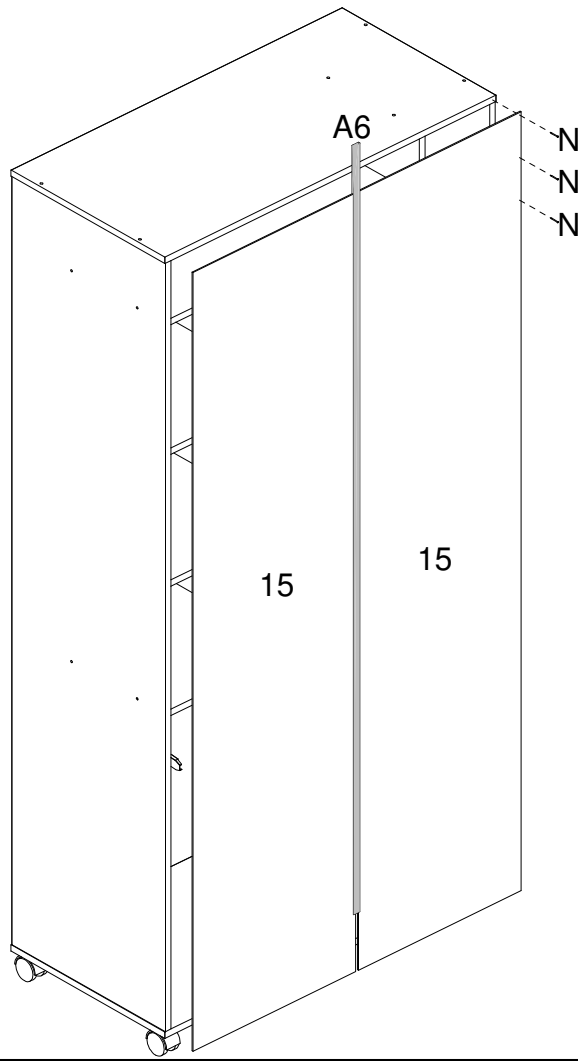

19

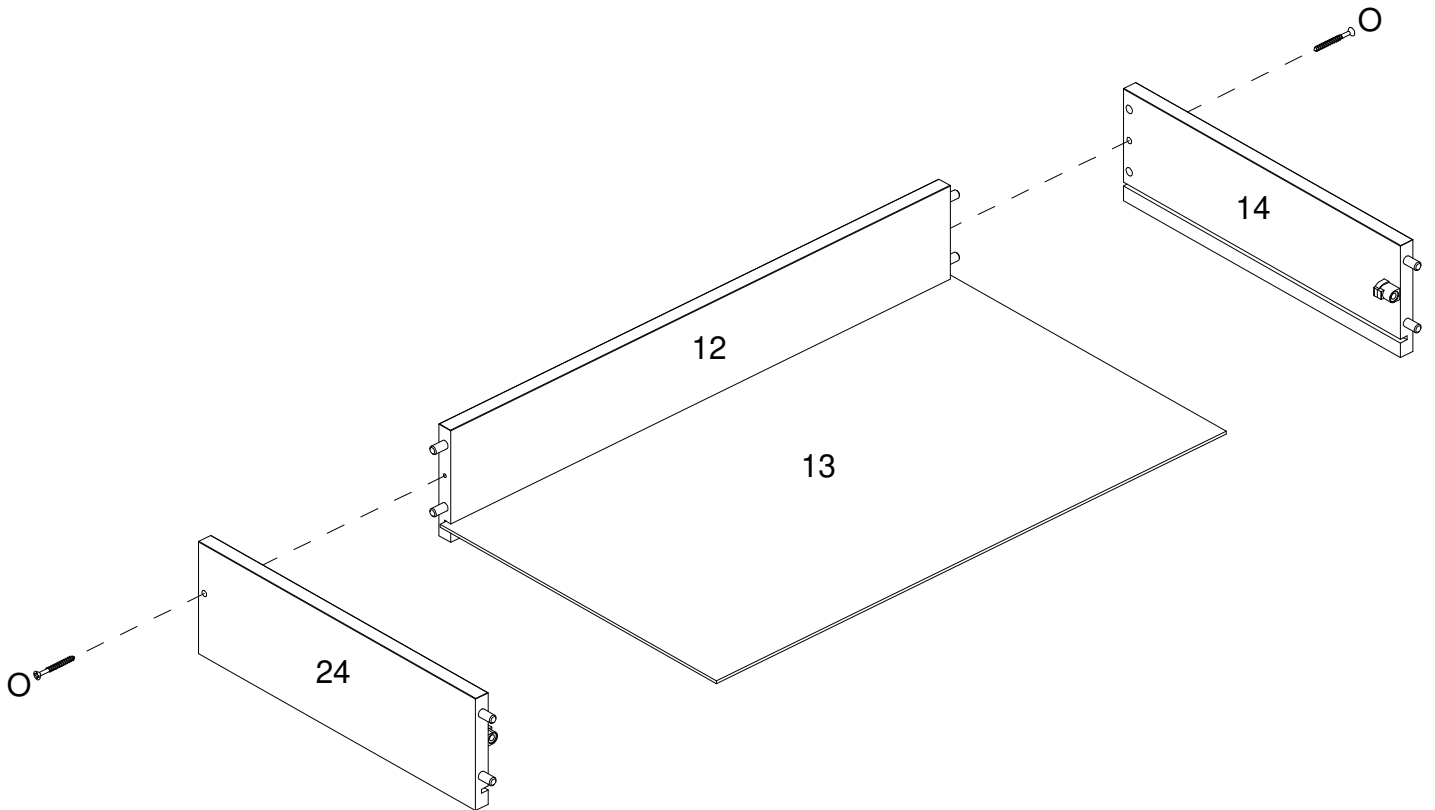

20

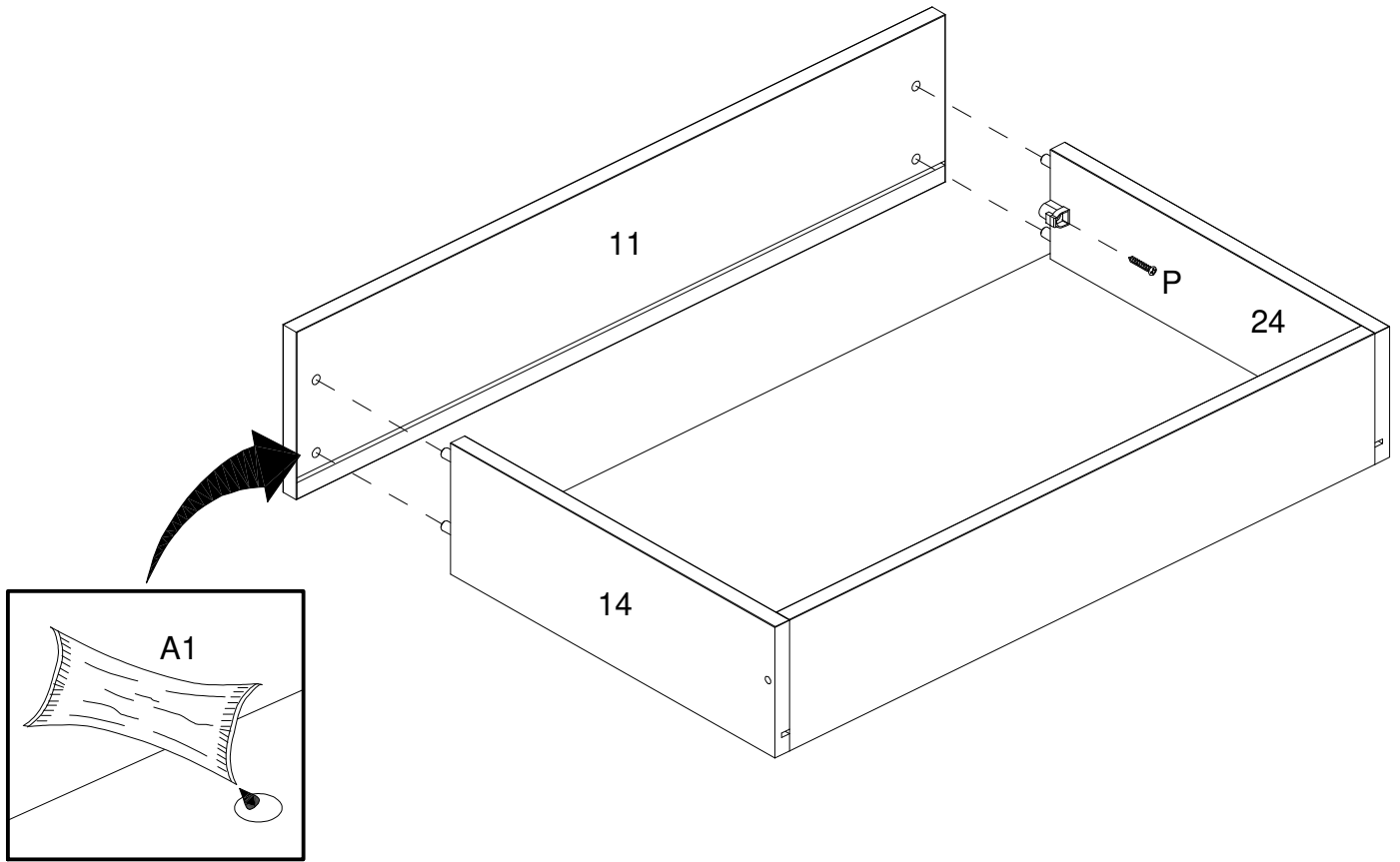

21

THE UNDERSIDE OF THE DRAWER  
LADO INFERIOR DA GAVETA  
PARTE INFERIOR DEL CAJÓN

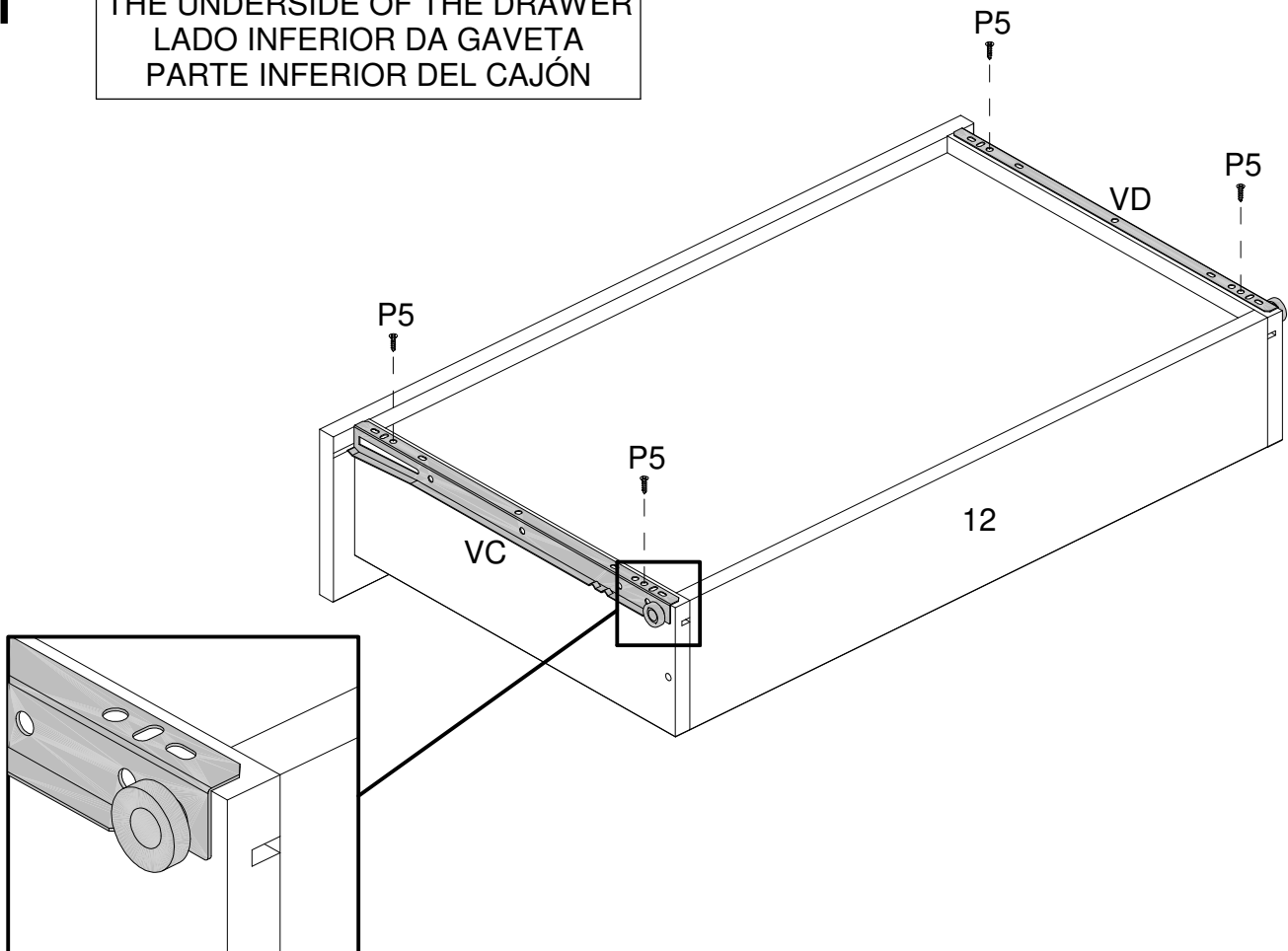

22

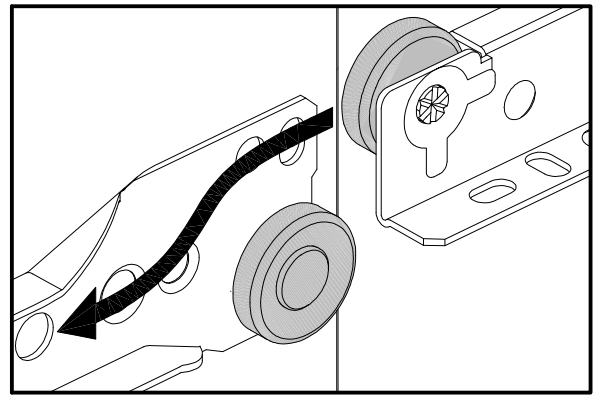
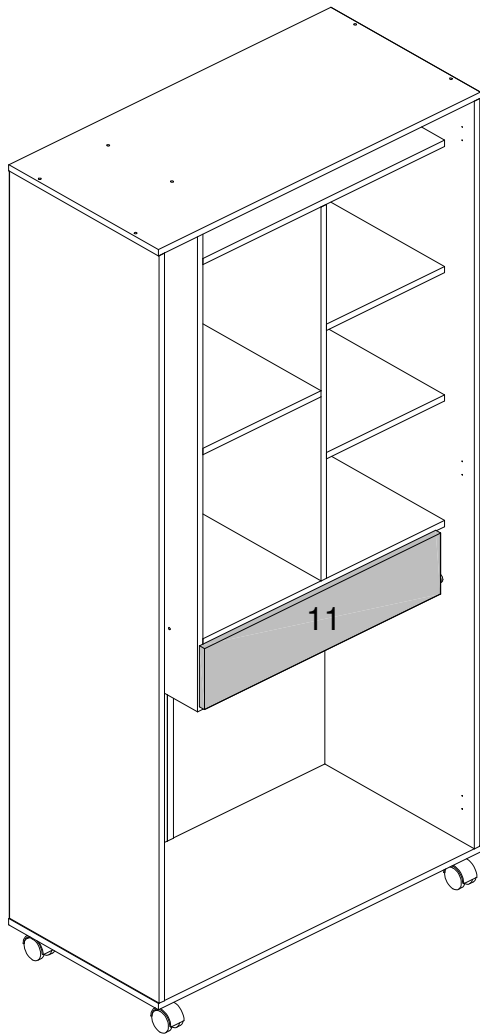

23

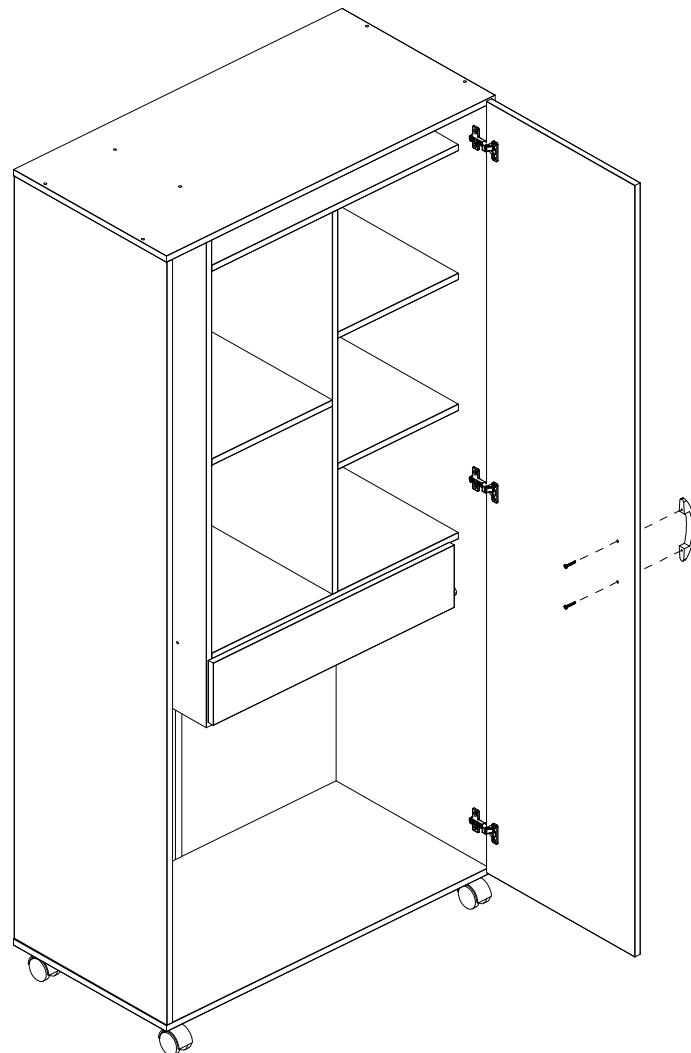
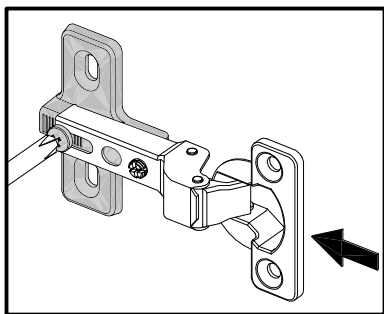

24

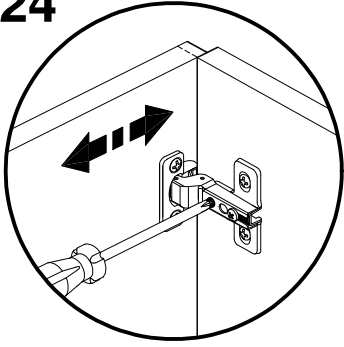

Horizontal Adjustment  
Regulagem Horizontal  
Ajuste Horizontal

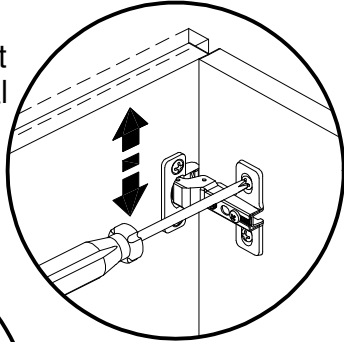

Vertical Adjustment  
Regulagem Vertical  
Ajuste Vertical

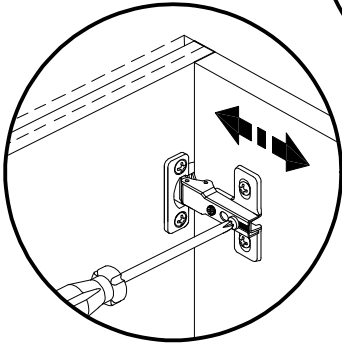

Depth Adjustment  
Regulagem Profundidade  
Ajuste Profundidad

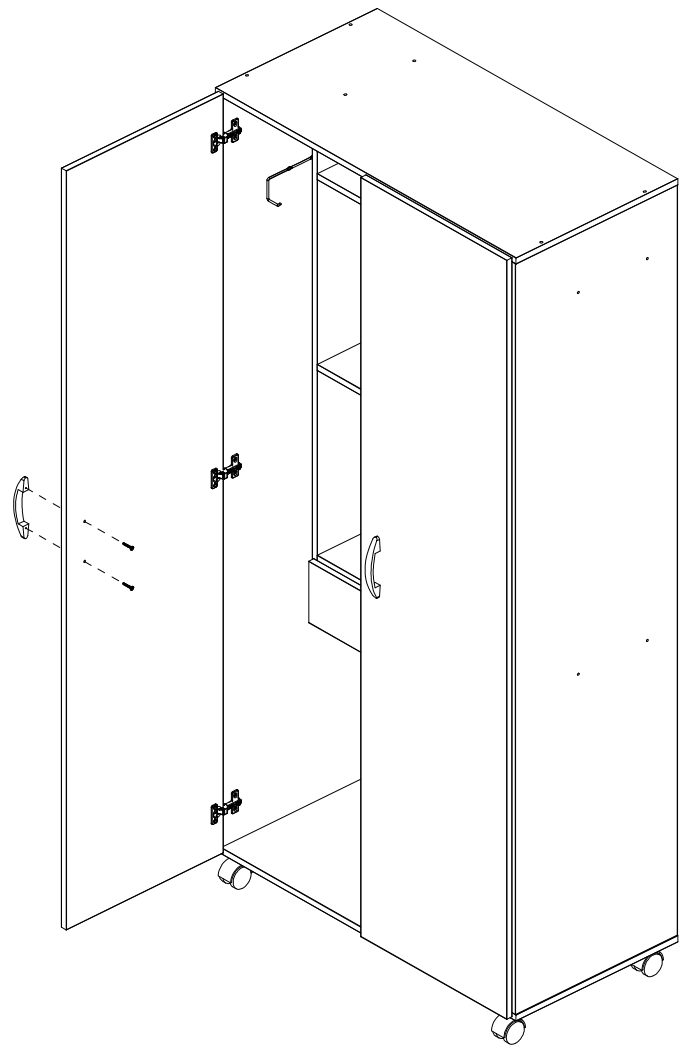

25

Choose the position of your choice!  
Escolha a posição de sua preferência!  
¡Elige la posición de tu elección!

