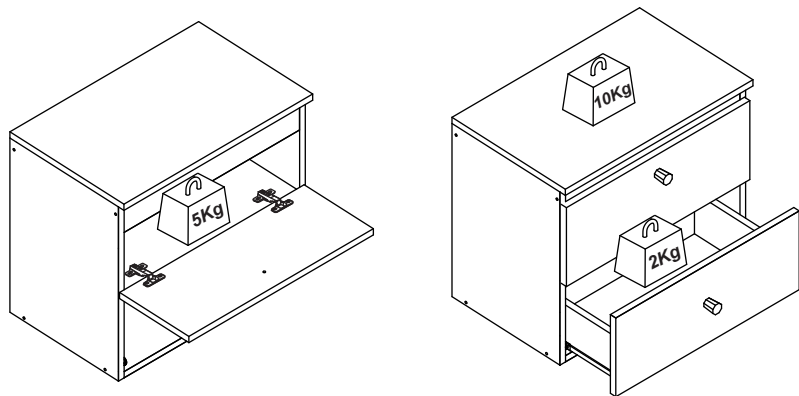
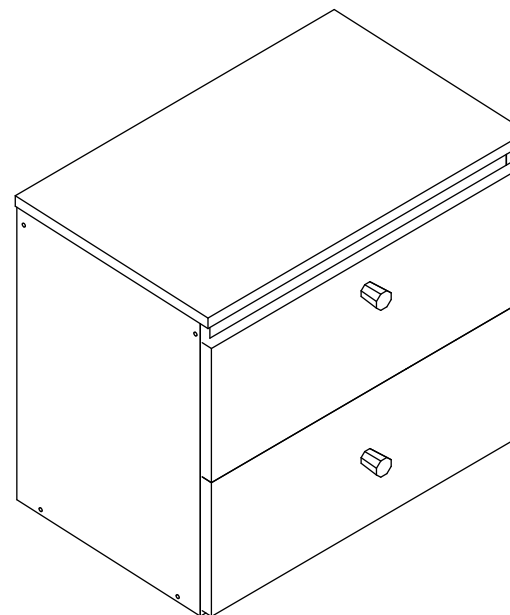
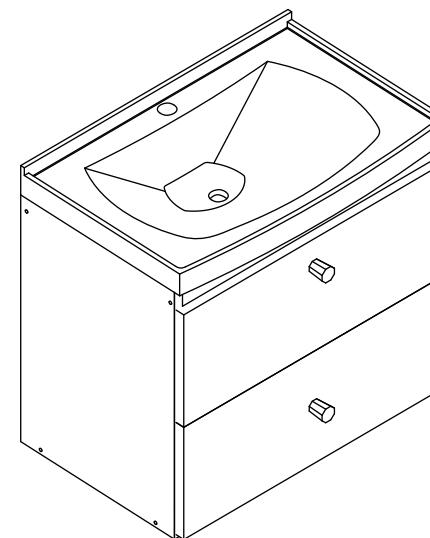

**14****PESO MÁXIMO SUPORTADO/MAXIMUM WEIGHT SUPPORTED  
PESO MAXIMO SOPORTADO****NOVA MÓBILE.****REF. LVT01****REF. LVP01****Manutenção e Limpeza:**

Use pano levemente umedecido com água, seguido de pano seco. Nunca utilize produtos químicos ou abrasivos.

**Maintenance and Cleaning:**

Use a cloth slightly dampened with water, followed by a dry cloth. Never use chemicals or abrasives.

**Mantenimiento y limpieza:**

Use un paño ligeramente humedecido con agua, seguido de un paño seco. Nunca use productos químicos o abrasivos.

**60 min.**

Ferramentas não incluídas  
Tools not included  
Herramientas no incluidas

Nova Móble Ind. e Comércio Ltda.

Estrada Pedro Salgado, nº 1620 - Fone: +55 (054) 2105-8400 - +55 (054) 99614-6360

CEP: 95706-500 - Bento Gonçalves - RS - Site: [www.novamobile.com.br](http://www.novamobile.com.br) - E-mail: [novamobile@novamobile.com.br](mailto:novamobile@novamobile.com.br)

Rev. 00 - 09/06/2022

# FERRAGENS / HARDWARE LIST / LISTA DE HERRAJES



## ATENÇÃO!!!







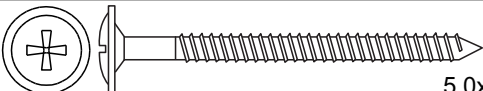

Em caso de uso de parafusadeira comece com um torque bem leve e vá aumentando até achar o ideal. Aperte somente até travar. Torque excessivo pode espanar o parafuso e danificar a peça comprometendo sua correta fixação.

## ATTENTION!!!

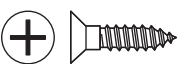
If using a screwdriver, start with a very light torque and increase until you find the ideal. Press only until it locks. Excessive torque can strip the bolt and damage the part, compromising its correct fixation.

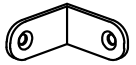
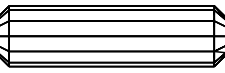
## ATENCIÓN!!!

En caso de utilizar un destornillador, comience con un torque muy ligero y vaya aumentando hasta encontrar el ideal. Presione solo hasta que se detener. Torsión excesivo puede despolvar el tornillo y dañar la pieza, comprometiendo su correcta fijación.

LOC.	IMAGEM / IMAGE / IMAGEN	QUANTIDADE # OF PIECES CANTIDAD
A	 5,0x60mm	02
B		02
C	 3,5x14mm	24
D	 3,5x12mm	05
E	 8 x 8	22
F		06
G	 8x30mm	24
H		10
I	 4,0x45mm	10
J	 4,0x25mm	02
K		02

# 12

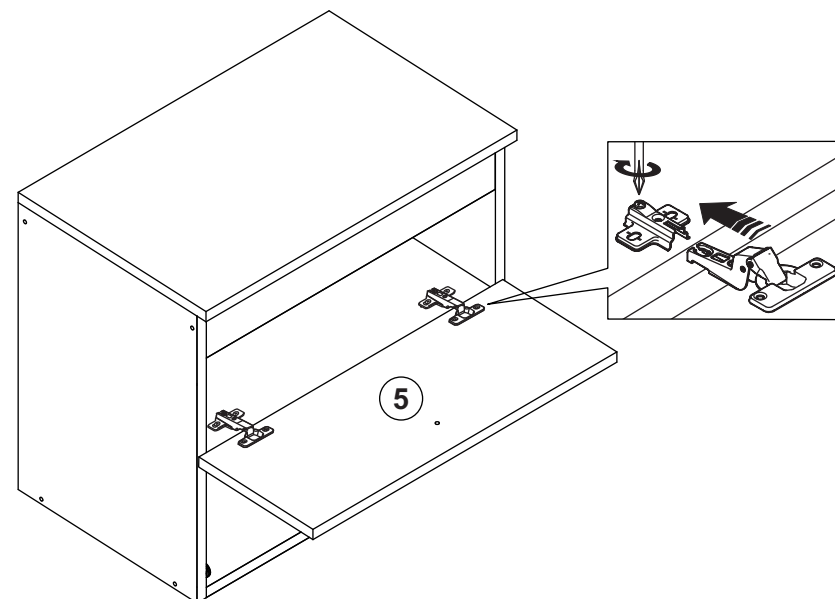

# 13

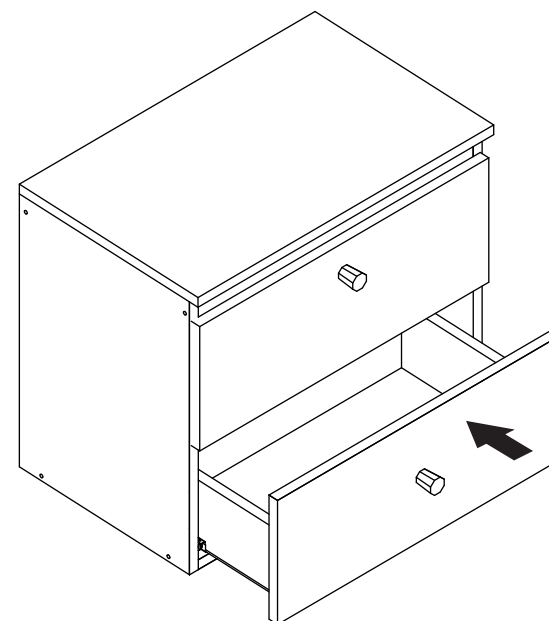

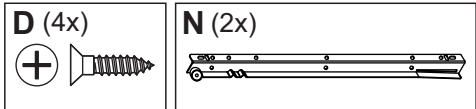
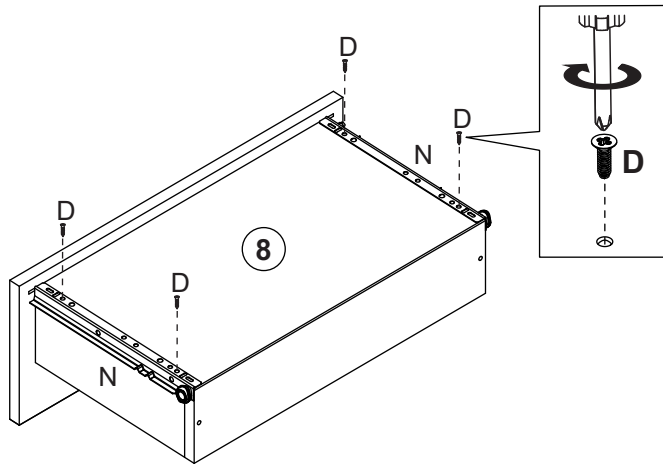
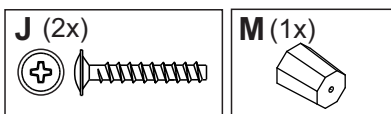
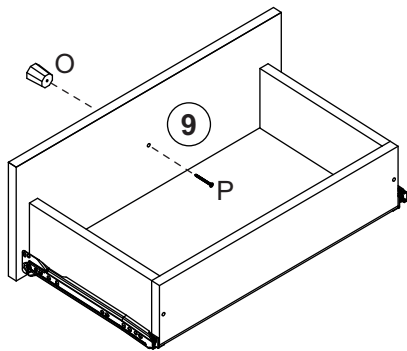
**10****11**

LOC.	IMAGEM / IMAGE / IMAGEN	QUANTIDADE # OF PIECES CANTIDAD
<b>L</b>		<b>01</b>
<b>M</b>		<b>02</b>
<b>N</b>	 250mm	<b>01</b>
<b>O</b>		<b>01</b>
<b>P</b>		<b>01</b>

**8**

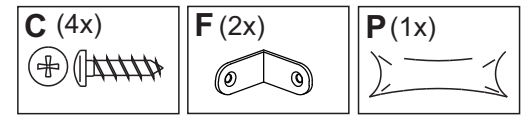
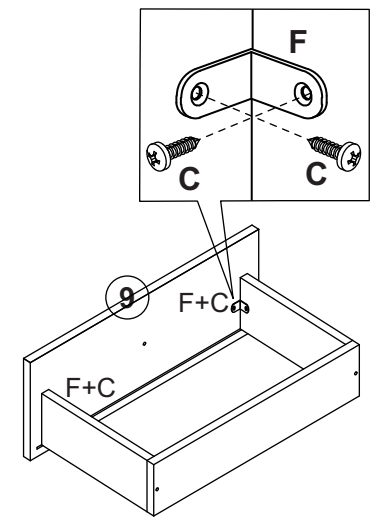
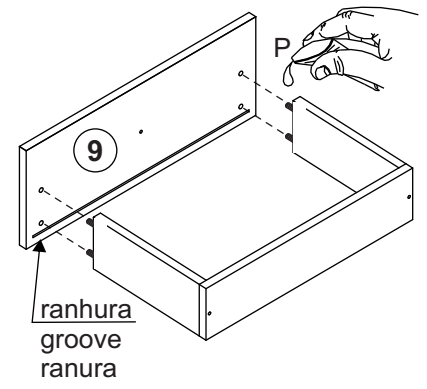
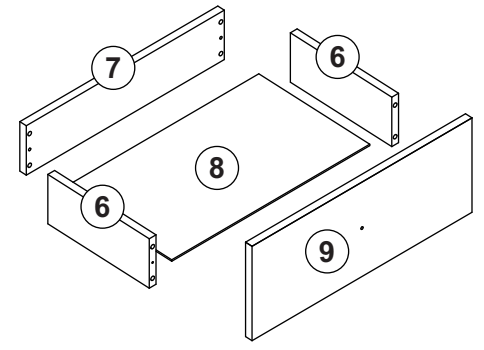
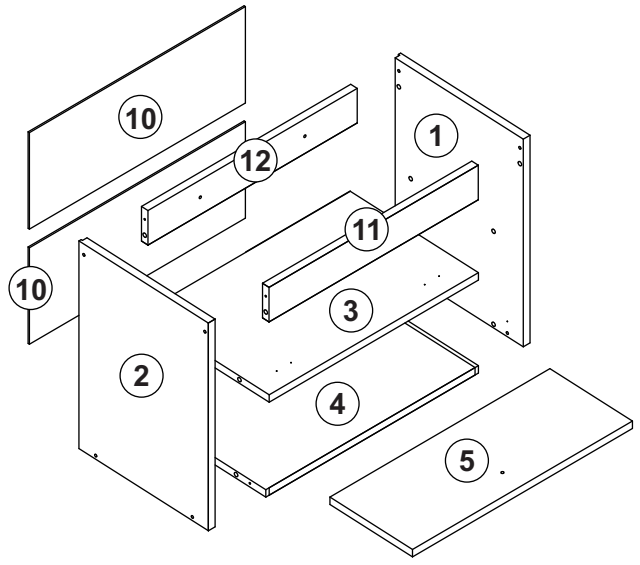

**9**

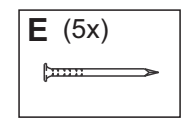
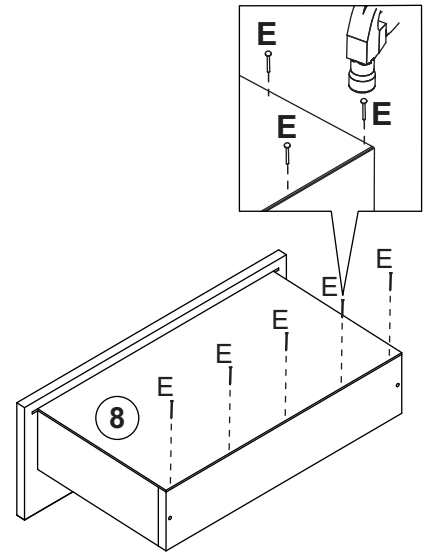
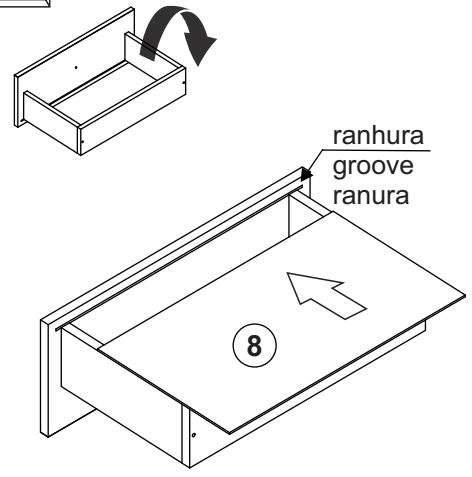

Loc.	Descrição / Description / Denominación	mm	Quantidade # Of Pieces Cantidad
1	Lateral direita/Right side/Lateral derecha	420x300x15	01
2	Lateral esquerda/Left side/Lateral izquierda	420x300x15	01
3	Base intermediária/Center base/Base del medio	465x297x15	01
4	Base inferior/Lower base/Base inferior	465x300x15	01
5	Porta/Door/Puerta	488x191x15	01
6	Lateral gaveta/Drawer side/Lateral cajón	335x100x15	02
7	Traseiro gaveta/Drawer back/Revés cajón	440x100x15	01
8	Fundo gaveta/Drawer bottom/Fondo cajón	440x257x3	01
9	Frente gaveta/Drawer front/Frente cajón	488x191x15	01
10	Costa/Back/Revés	481x188x3	02
11	Travessa superior frontal/Upper front traverse/Travesaño superior delantero	465x70x15	01
12	Travessa superior traseira/Upper back traverse/Travesaño superior de atras	465x70x15	01

6

OPÇÕES DE TAMPO/TOP OPTION/OPCIONES DE CUBIERTA

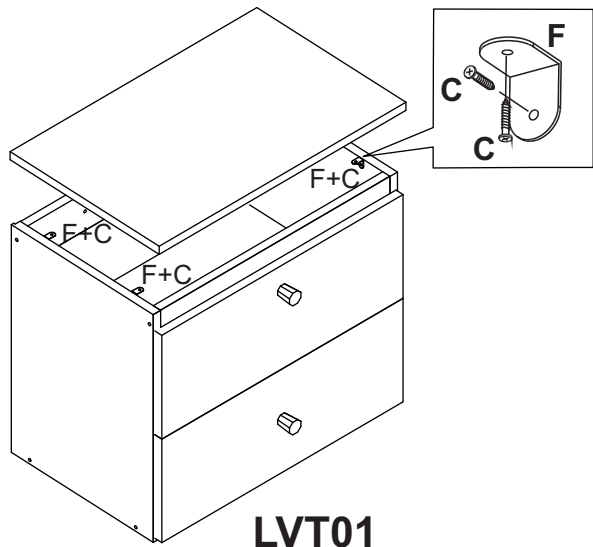

LVT01

Para instalação da pia, deve ser utilizado equipamento adequado [serra-copo] com diâmetro suficiente para a passagem dos canos e/ou mangueiras.

For installation of the sink, suitable equipment must be used, a saw with a diameter sufficient for the passage of pipes and/or hoses.

Para la instalación del fregadero, se debe utilizar un equipo adecuado, una sierra con diámetro suficiente para el paso de tuberías y/o mangueras.

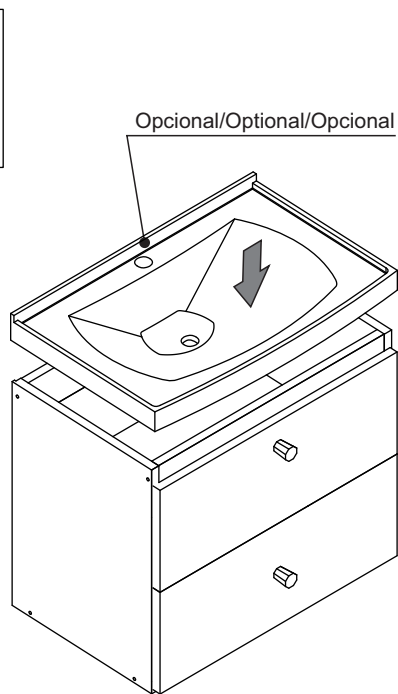

LVP01

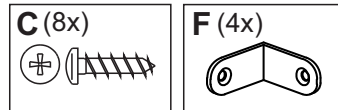

7

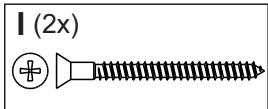
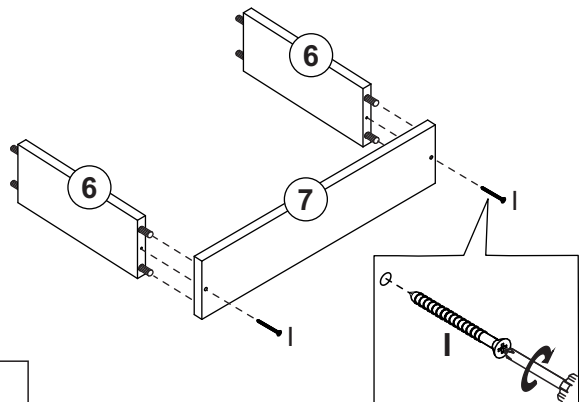

1

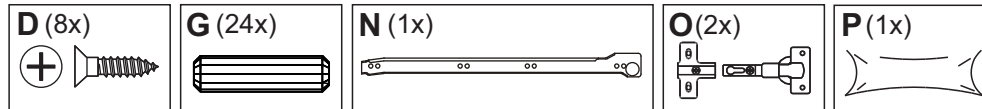
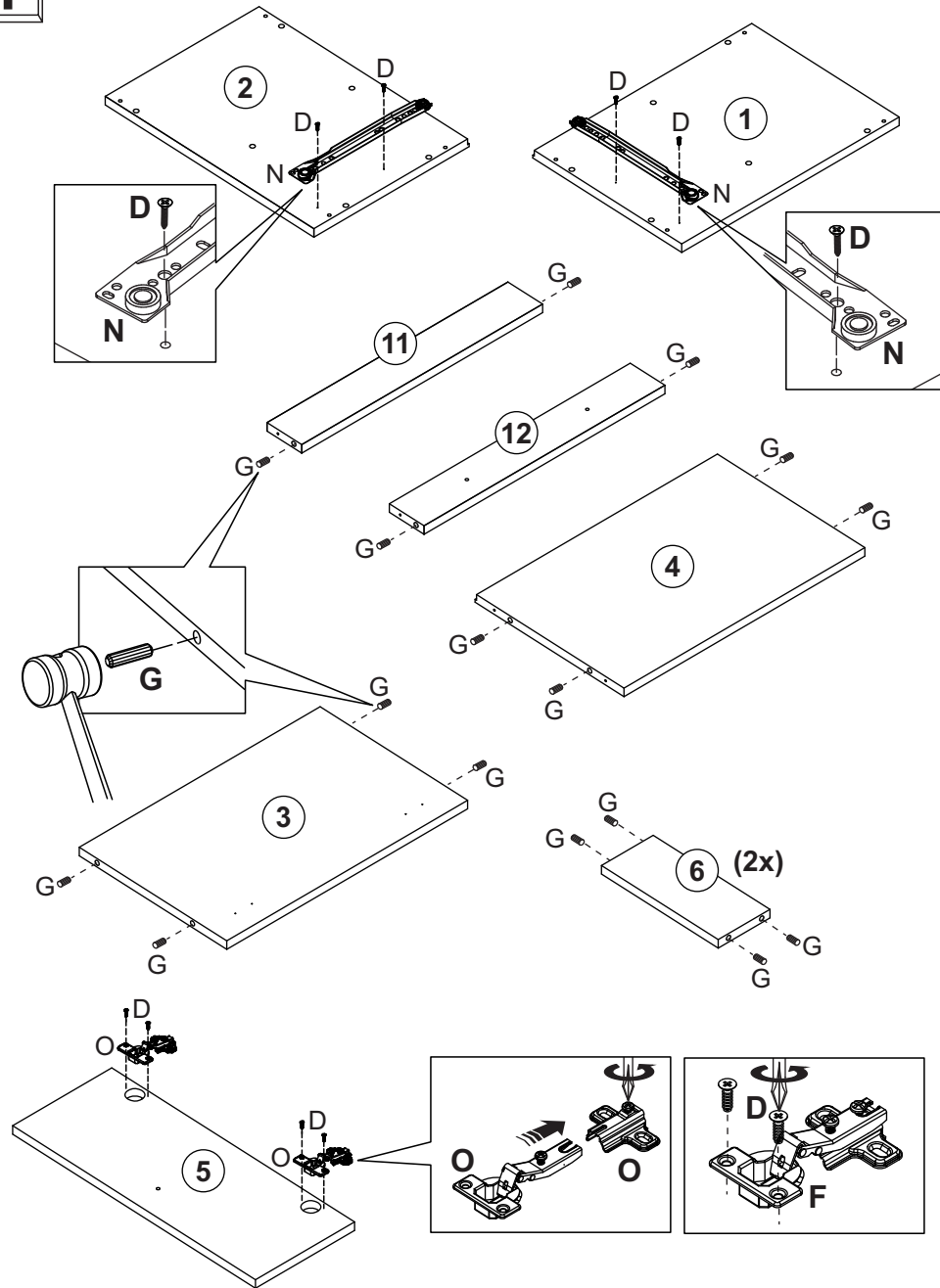

2

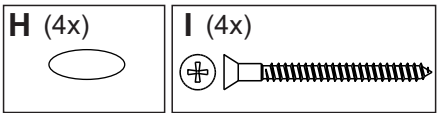
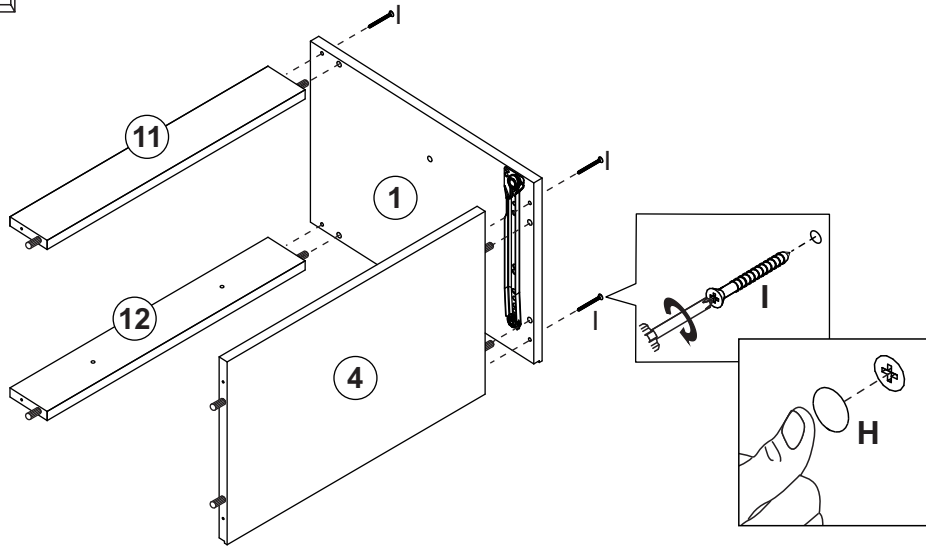

3

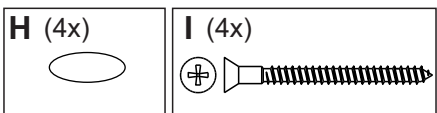
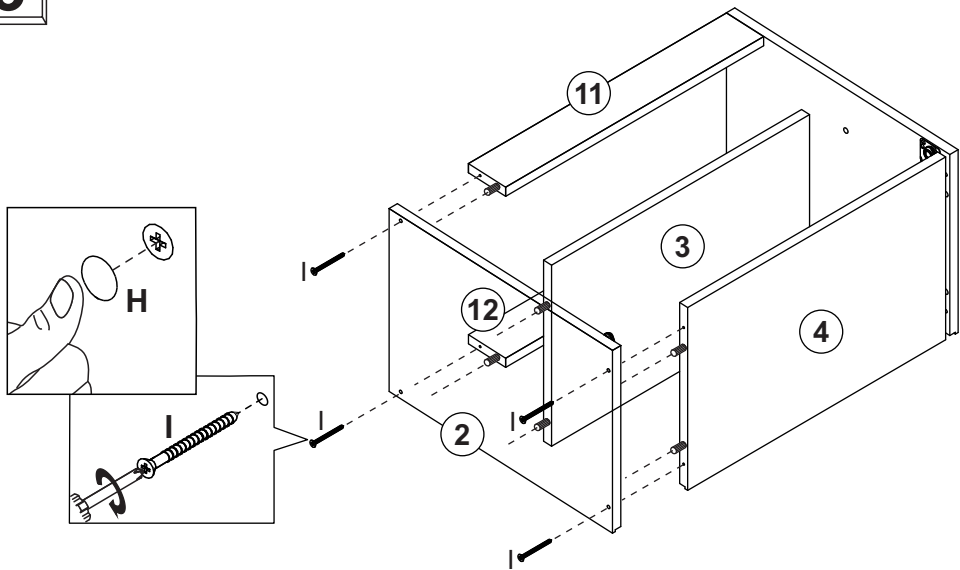

4

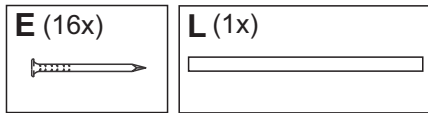
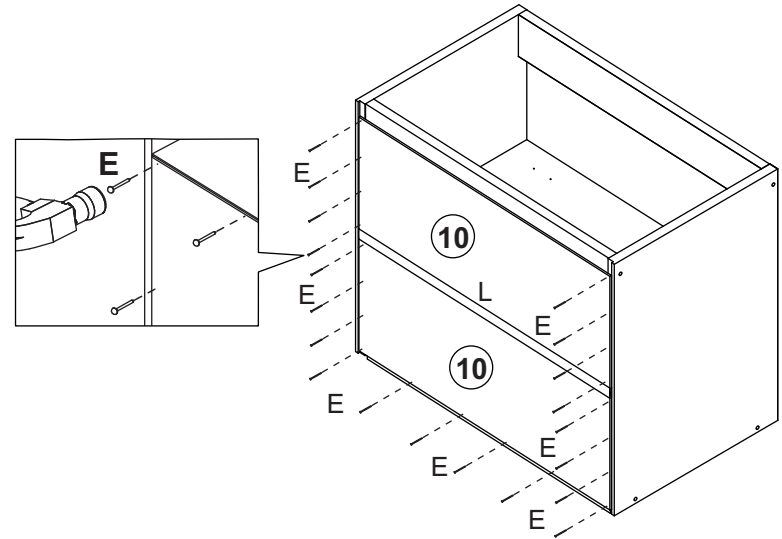

5

