

8

PESO MÁXIMO SUPORTADO
MAXIMUM WEIGHT SUPPORTED
PESO MAXIMO SOPORTADO

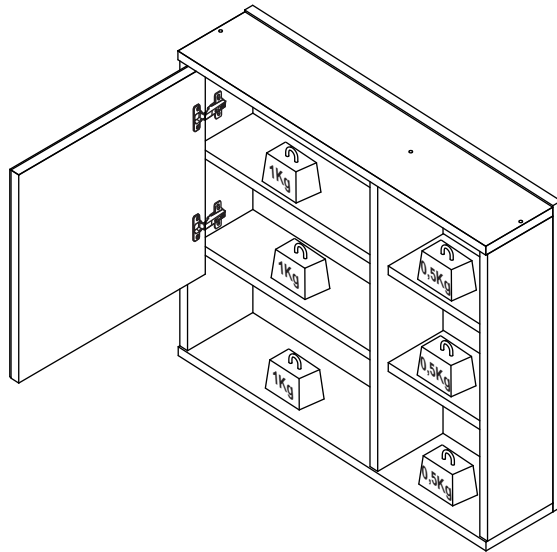

NOVA MÓBILE.

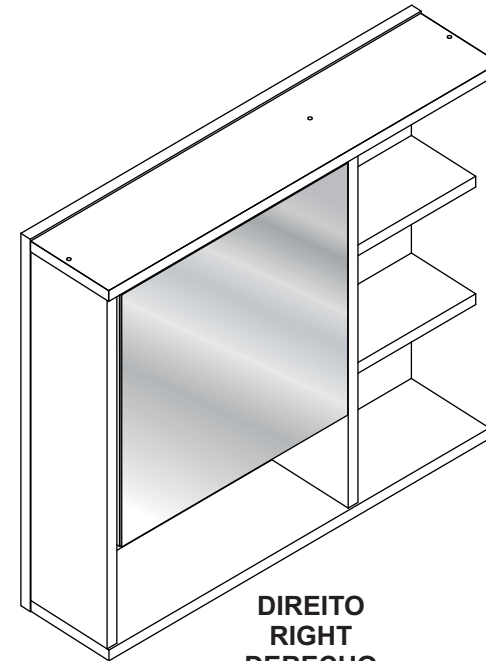

DIREITO
RIGHT
DERECHO

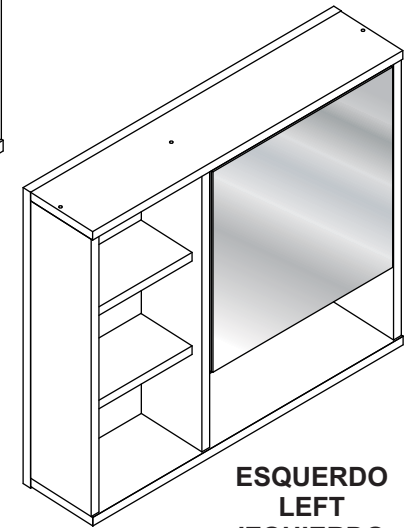

ESQUERDO
LEFT
IZQUIERDO

REF. LVA06

Manutenção e Limpeza:

Use pano levemente umedecido com água, seguido de pano seco. Nunca utilize produtos químicos ou abrasivos.

Maintenance and Cleaning:

Use a cloth slightly dampened with water, followed by a dry cloth. Never use chemicals or abrasives.

Mantenimiento y limpieza:

Use un paño ligeramente humedecido con agua, seguido de un paño seco. Nunca use productos químicos o abrasivos.



60 min.

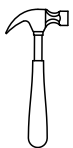

Nova MóBILE Ind. e Comércio Ltda.

Estrada Pedro Salgado, nº 1620 - Fone: +55 (054) 2105-8400 - +55 (054) 99614-6360

CEP: 95706-500 - Bento Gonçalves - RS - Site: www.novamobile.com.br - E-mail: novamobile@novamobile.com.br

Rev. 00 - 13/05/2022

FERRAGENS / HARDWARE LIST / LISTA DE HERRAJES



ATENÇÃO!!!





Em caso de uso de parafusadeira comece com um torque bem leve e vá aumentando até achar o ideal. Aperte somente até travar. Torque excessivo pode espanar o parafuso e danificar a peça comprometendo sua correta fixação.

ATTENTION!!!

If using a screwdriver, start with a very light torque and increase until you find the ideal. Press only until it locks. Excessive torque can strip the bolt and damage the part, compromising its correct fixation.

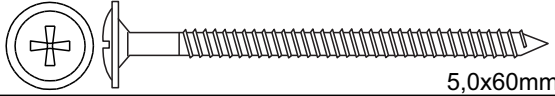
ATENCIÓN!!!

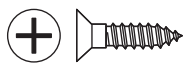
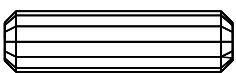
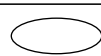
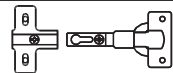
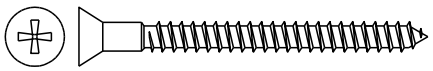
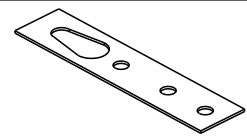
En caso de utilizar un destornillador, comience con un torque muy ligero y vaya aumentando hasta encontrar el ideal. Presione solo hasta que se detener. Torsión excesivo puede despolvar el tornillo y dañar la pieza, comprometiendo su correcta fijación.

LOC.	IMAGEM / IMAGE / IMAGEN	QUANTIDADE # OF PIECES CANTIDAD
A	 5,0x60mm	02
B		02
C	 3,5x14mm	14
D	 8x30mm	30
E		08
F		02
G	 4,0x45mm	16
H		02
I		08

6 FIXAÇÃO NA PAREDE/FIXING ON THE WALL/FIJACIÓN EN LA PARED

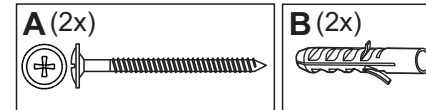
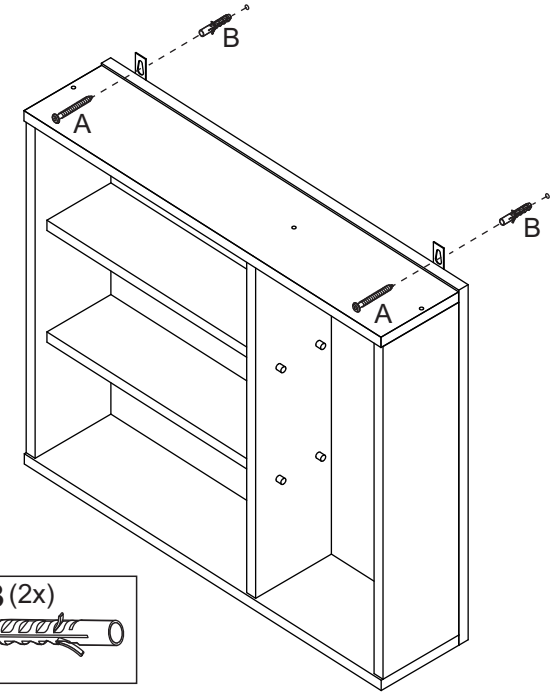

7

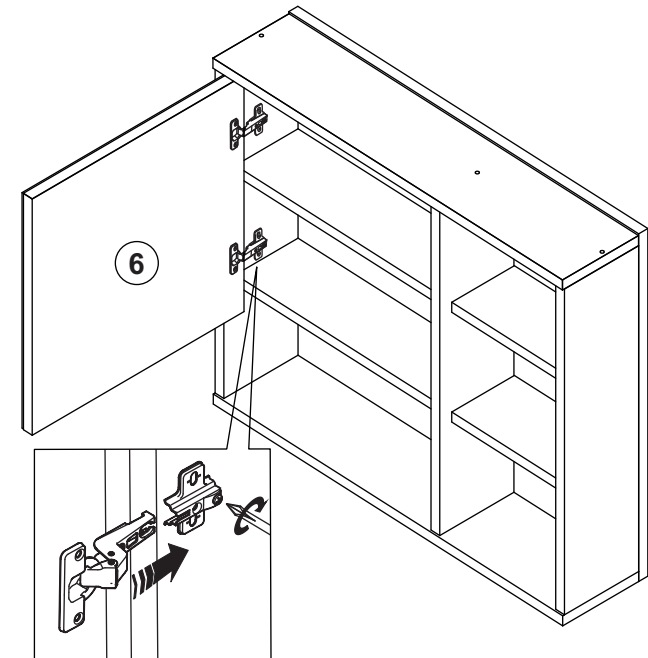

4

PARTES DO PRODUTO / PRODUCT PARTS / PARTES DEL PRODUCTO

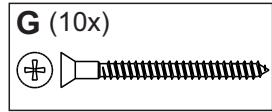
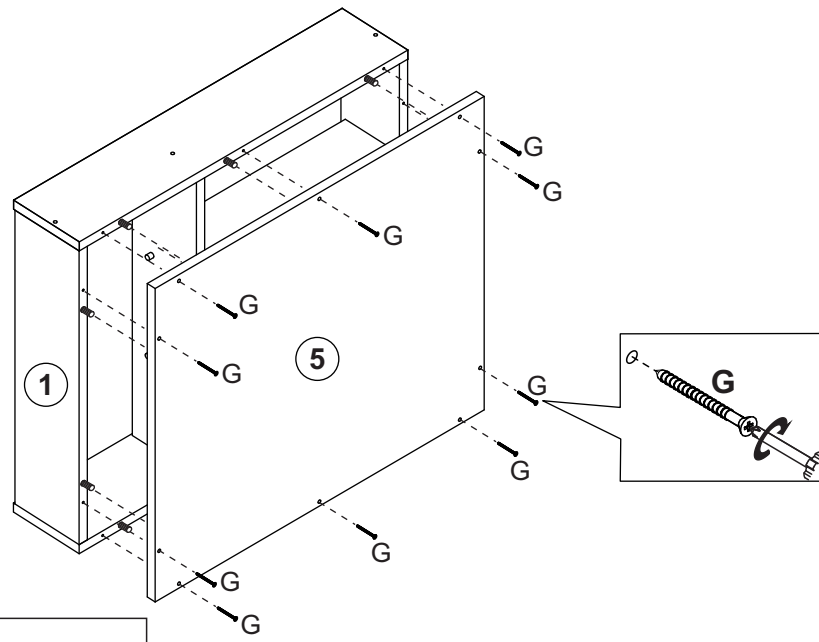

5

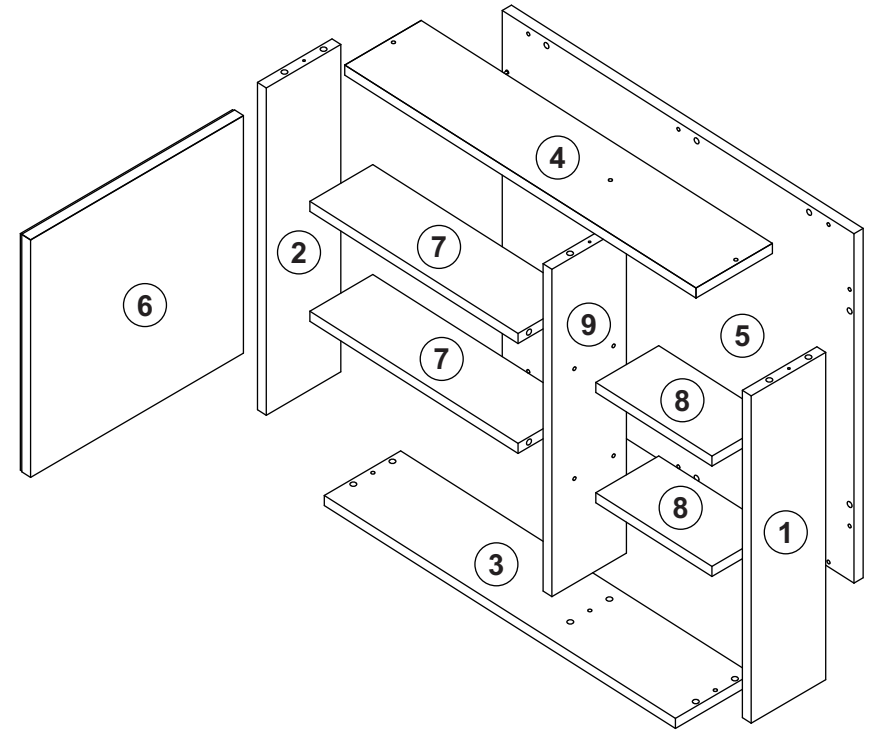
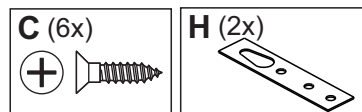
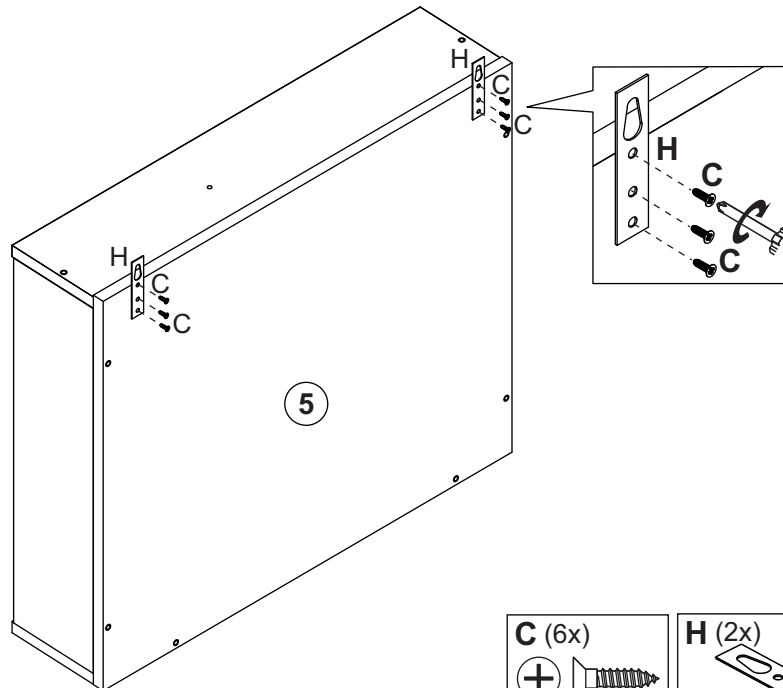

Loc.	Descrição / Description / Denominación	mm	Quantidade # Of Pieces Cantidad
1	Lateral direita/Right side/Lateral derecha	484x122x15	01
2	Lateral esquerda/Left side/Lateral izquierda	484x122x15	01
3	Base/Base/Base	599x125x15	01
4	Tampo/Top/Tapa	599x125x15	01
5	Painel traseiro/Back panel/Panel de atras	520x600x15	01
6	Porta/Door/Puerta	351x351x15	01
7	Prateleira fixa/Fixed shelf/Repisa fija	355x103x15	02
8	Prateleira móvel/Mobile shelf/Repisa móvil	196x103x15	02
9	Divisão/Divider/Divisória	484x122x15	01

1

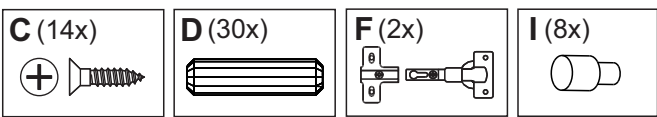
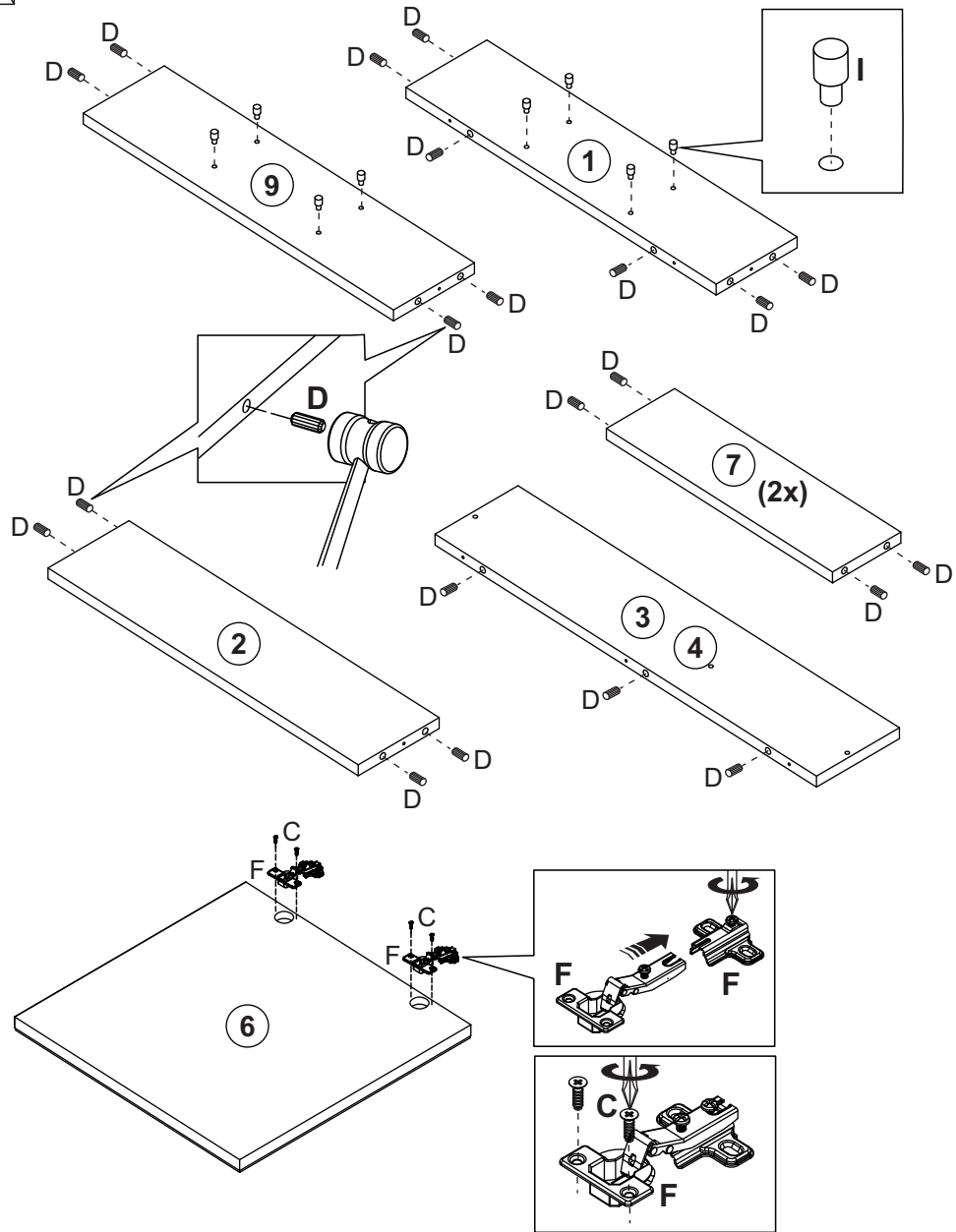

2

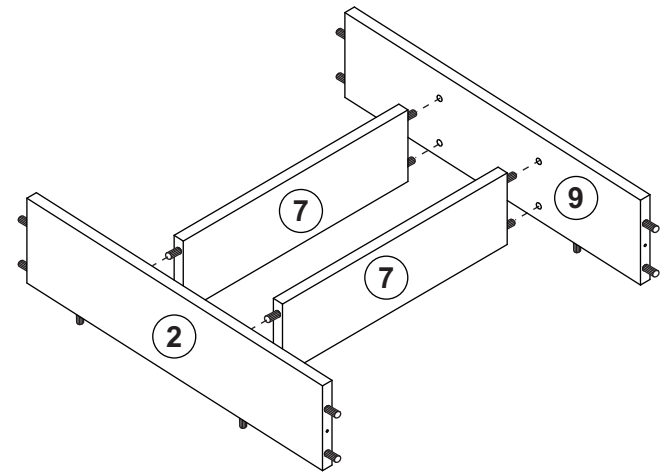

3

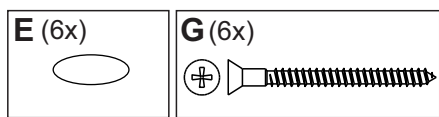
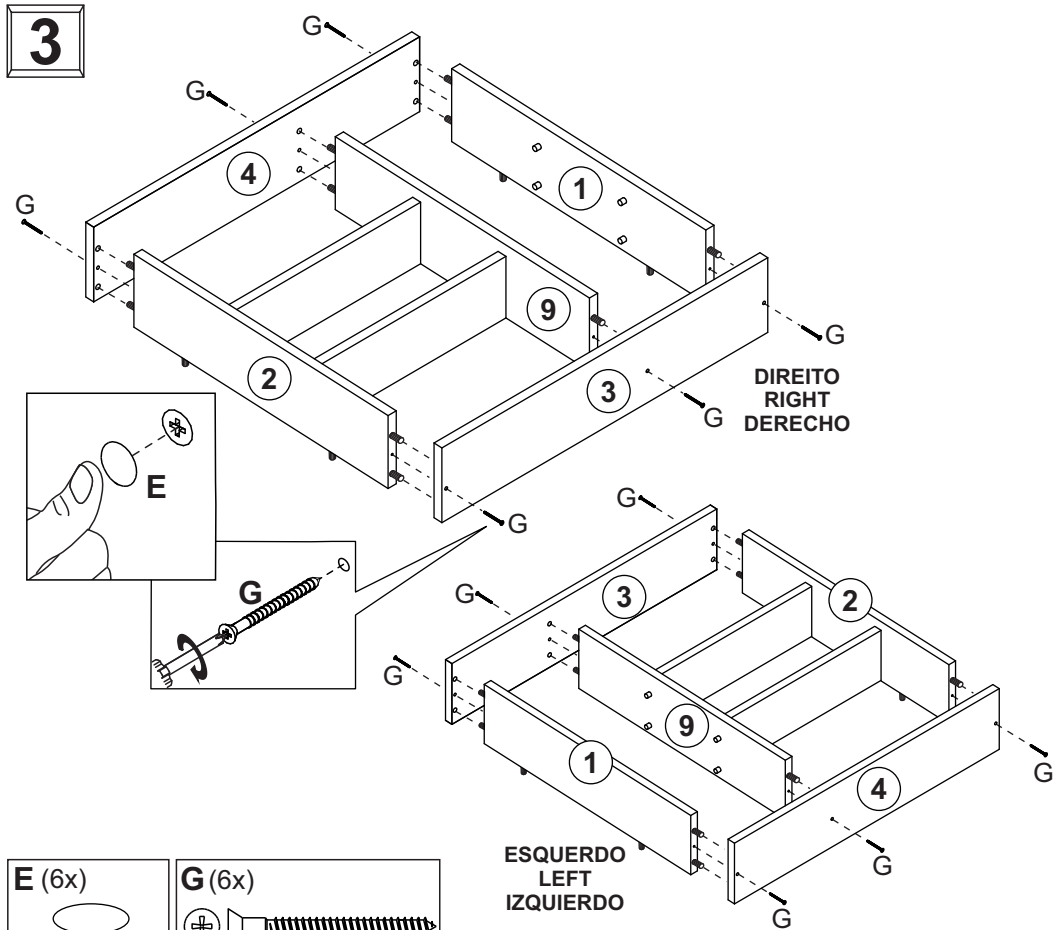

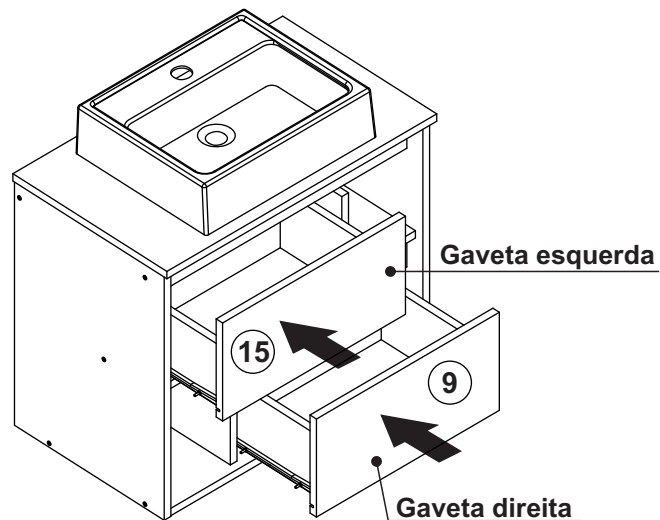
14

NOVA MÓBILE.

15

PESO MÁXIMO SUPORTADO/MAXIMUM WEIGHT SUPPORTED
PESO MAXIMO SOPORTADO

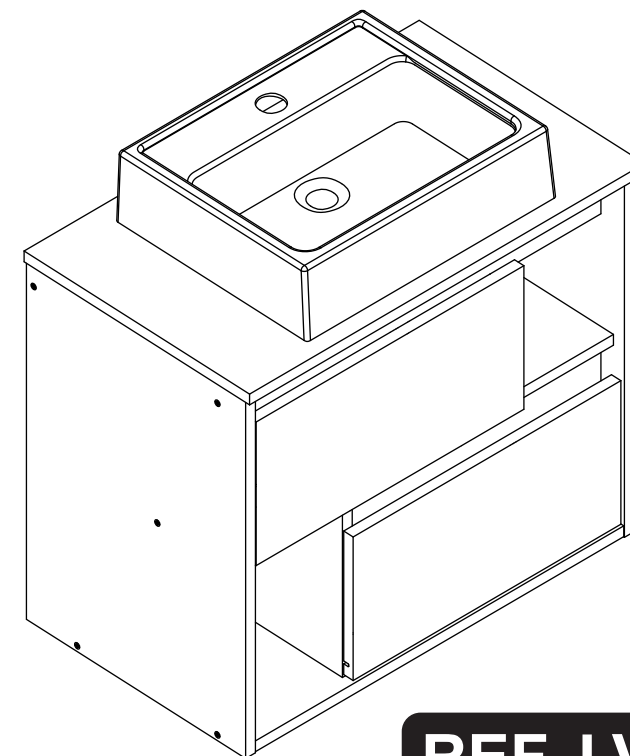
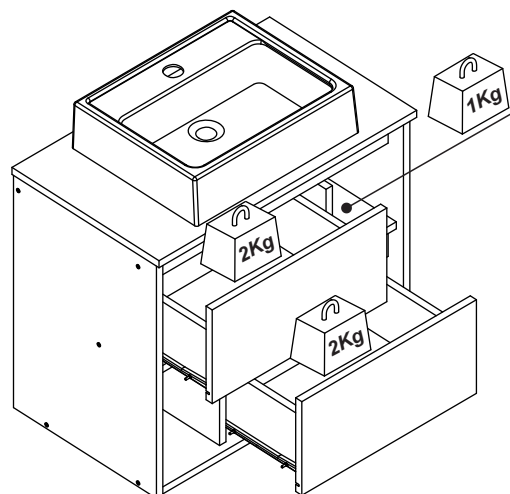
**REF. LVP03****Manutenção e Limpeza:**

Use pano levemente umedecido com água, seguido de pano seco. Nunca utilize produtos químicos ou abrasivos.

Maintenance and Cleaning:

Use a cloth slightly dampened with water, followed by a dry cloth. Never use chemicals or abrasives.

Mantenimiento y limpieza:

Use un paño ligeramente humedecido con agua, seguido de un paño seco. Nunca use productos químicos o abrasivos.

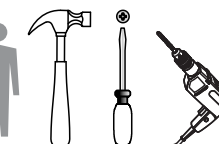
**60 min.**

Ferramentas não inclusas
 Tools not included
 Herramientas no incluidas

Nova MóBILE Ind. e Comércio Ltda.

Estrada Pedro Salgado, nº 1620 - Fone: +55 (054) 2105-8400 - +55 (054) 99614-6360

CEP: 95706-500 - Bento Gonçalves - RS - Site: www.novamobile.com.br - E-mail: novamobile@novamobile.com.br

Rev. 00 - 10/06/2022

FERRAGENS / HARDWARE LIST / LISTA DE HERRAJES



ATENÇÃO!!!

Em caso de uso de parafusadeira comece com um torque bem leve e vá aumentando até achar o ideal. Aperte somente até travar. Torque excessivo pode espanar o parafuso e danificar a peça comprometendo sua correta fixação.

ATTENTION!!!

If using a screwdriver, start with a very light torque and increase until you find the ideal. Press only until it locks. Excessive torque can strip the bolt and damage the part, compromising its correct fixation.

ATENCIÓN!!!

En caso de utilizar un destornillador, comience con un torque muy ligero y vaya aumentando hasta encontrar el ideal. Presione solo hasta que se detener. Torsión excesivo puede despolvar el tornillo y dañar la pieza, comprometiendo su correcta fijación.

LOC.	IMAGEM / IMAGE / IMAGEN	QUANTIDADE # OF PIECES CANTIDAD
A	5,0x60mm	02
B		02
C		28
D		09
E		30
F		10
G		48
H		12
I		18
J		02
K		02

12

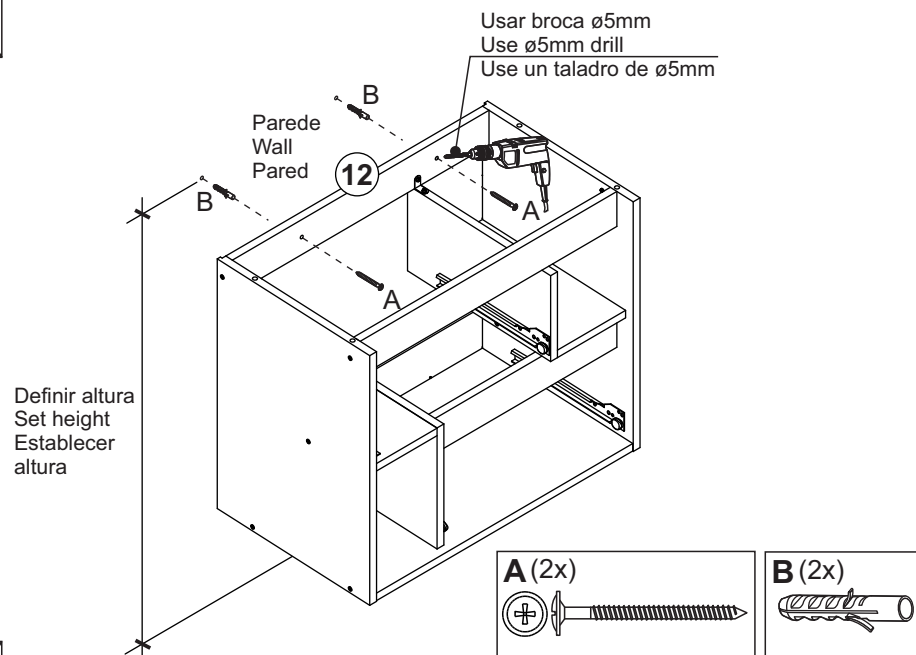

13

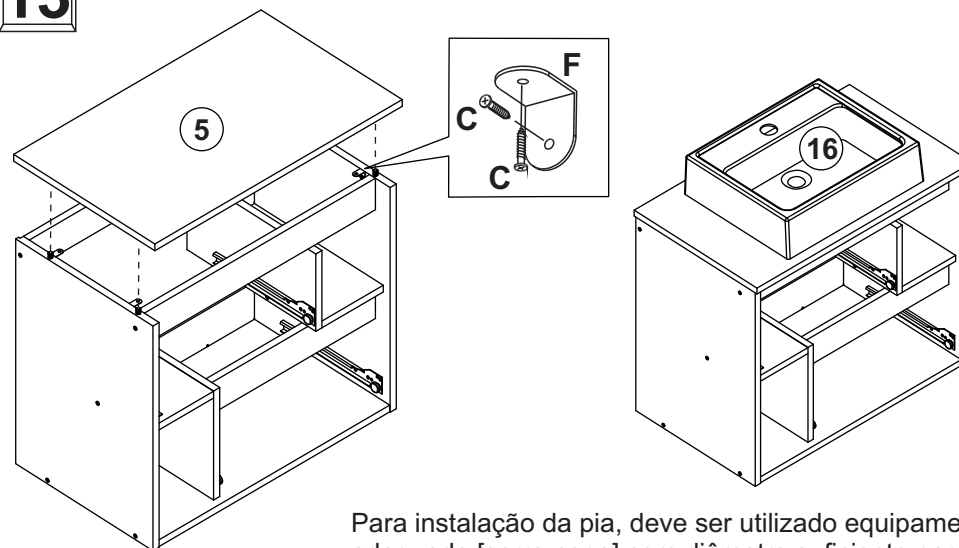

Para instalação da pia, deve ser utilizado equipamento adequado [serra-copo] com diâmetro suficiente para a passagem dos canos e/ou mangueiras.
For installation of the sink, suitable equipment must be used, a saw with a diameter sufficient for the passage of pipes and/or hoses.

Para la instalación del fregadero, se debe utilizar un equipo adecuado, una sierra con diámetro suficiente para el paso de tuberías y/o mangueras.

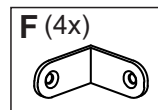
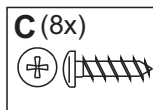

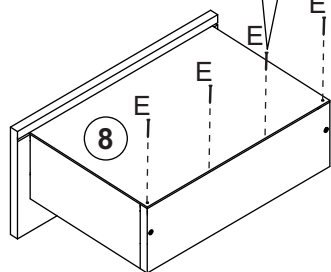
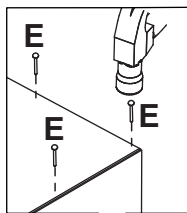
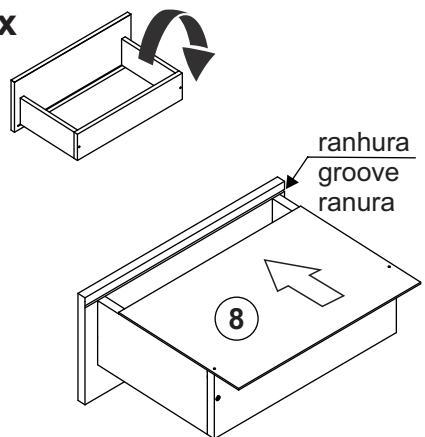
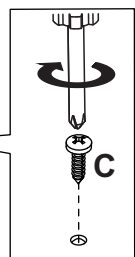
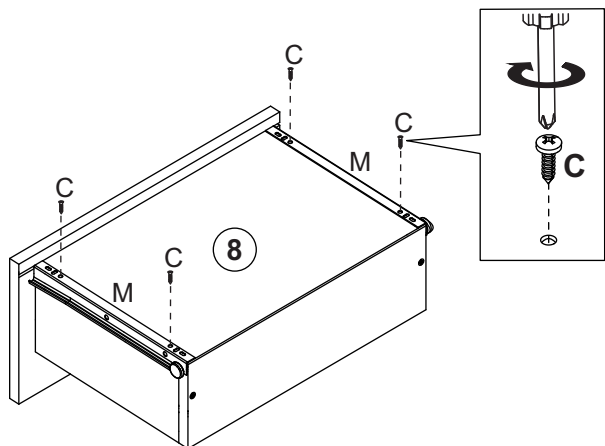
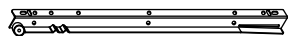
10**2x****E (8x)****11****2x****C (8x)****M (2x)**

LOC.	IMAGEM / IMAGE / IMAGEN	QUANTIDADE # OF PIECES CANTIDAD
L	 565mm	01
M	 250mm	02

PARTES DO PRODUTO / PRODUCT PARTS / PARTES DEL PRODUCTO

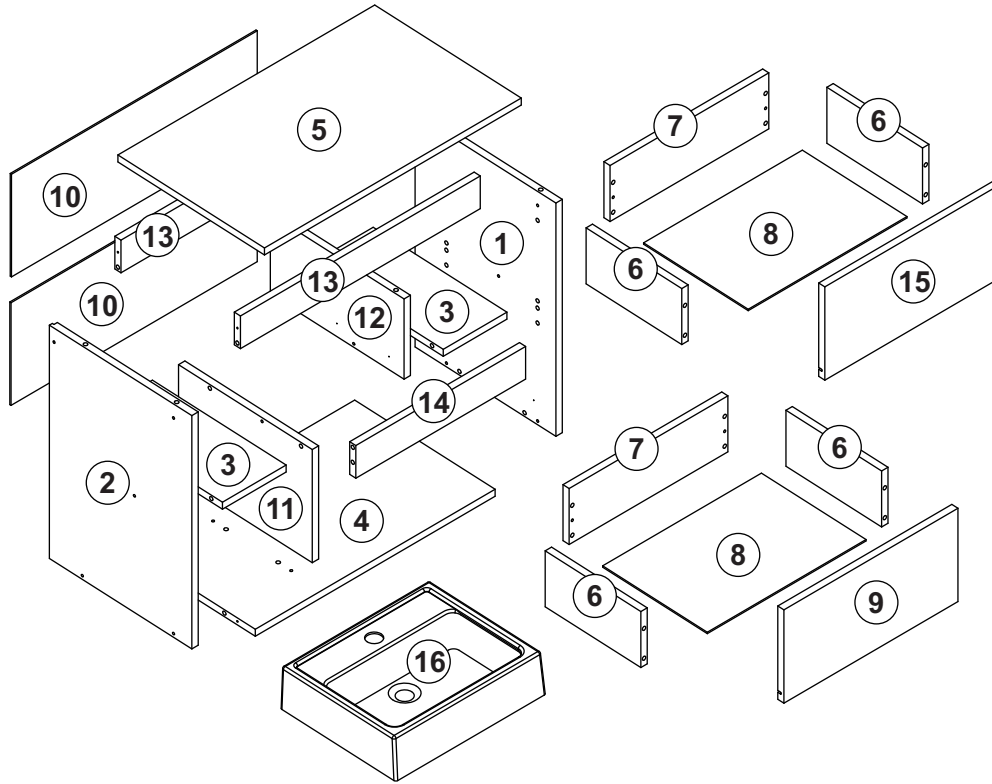

8

2x

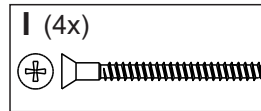
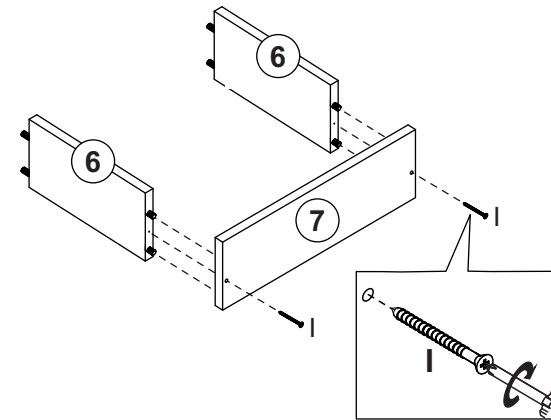

9

2x

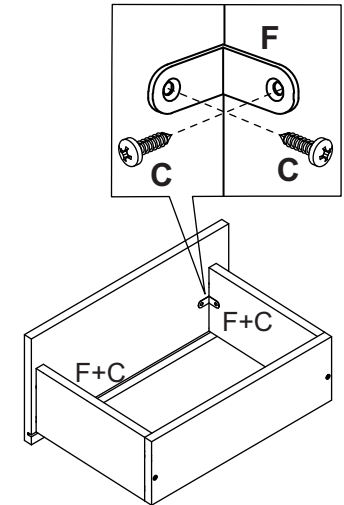
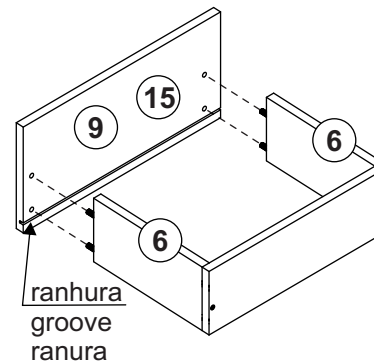

Loc.	Descrição / Description / Denominación	mm	Quantidade # Of Pieces Cantidad
1	Lateral direita/Right side/Lateral derecha	500x350x15	01
2	Lateral esquerda/Left side/Lateral izquierda	500x350x15	01
3	Base intermediária/Center base/Base del medio	150x328,5x15	02
4	Base inferior/Lower base/Base inferior	565x349x15	01
5	Tampo/Top/Tapa	605x360x15	01
6	Lateral gaveta/Drawer side/Lateral cajón	235x100x15	04
7	Traseiro gaveta/Drawer back/Revés cajón	374x100x15	02
8	Fundo gaveta/Drawer bottom/Fondo cajón	374x257x3	02
9	Frente gaveta direita/Right drawer front/Frente cajón derecha	410x200x15	01
10	Costa/Back/Revés	579x225x3	02
11	Divisão inferior/Lower divider/Divisória inferior	242,5x328,5x15	01
12	Divisão superior/Upper divider/Divisória superior	172x328,5x15	01
13	Travessa superior/Upper traverse/Travesaño superior	565x70x15	02
14	Travessa intermediário/Intermediary traverse/Travesaño del medio	400x70x15	02
15	Frente gaveta esquerda/Left drawer front/Frente cajón izquierdo	410x200x15	01
16	Pia/Lavatory/Lavatorio	-	01

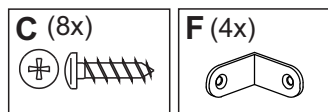

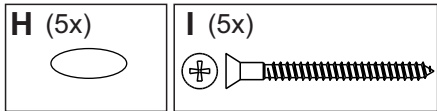
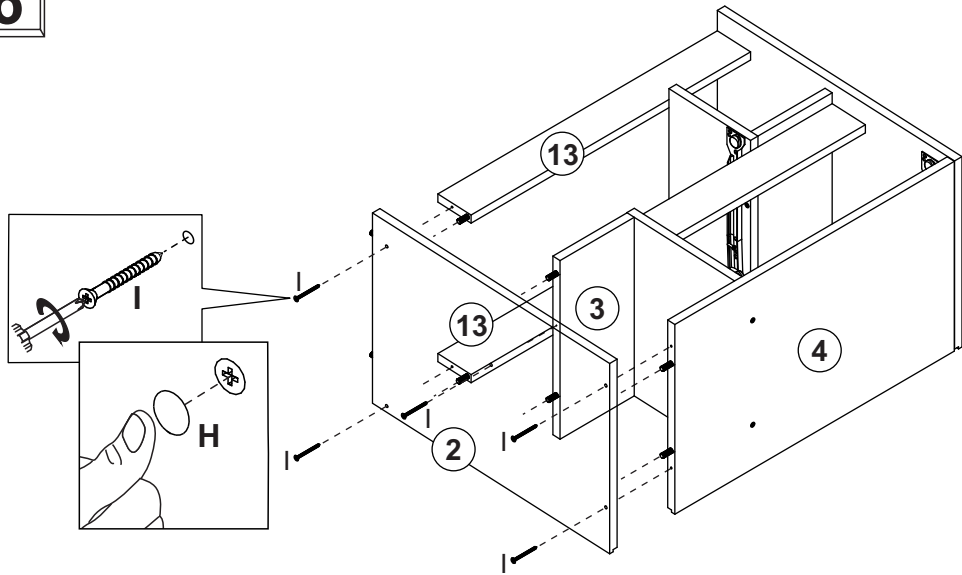
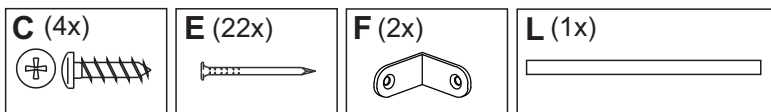
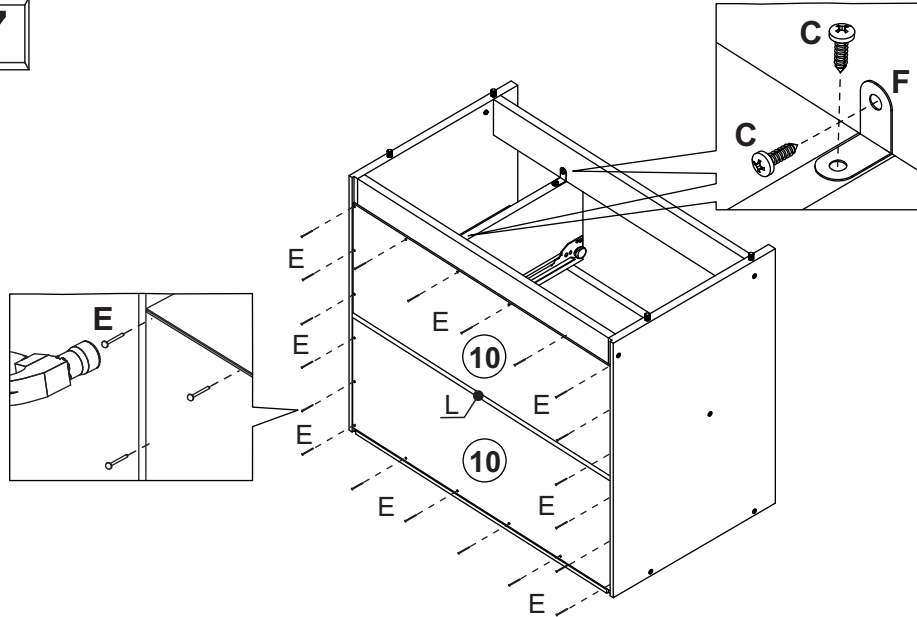
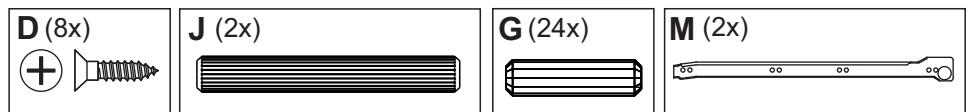
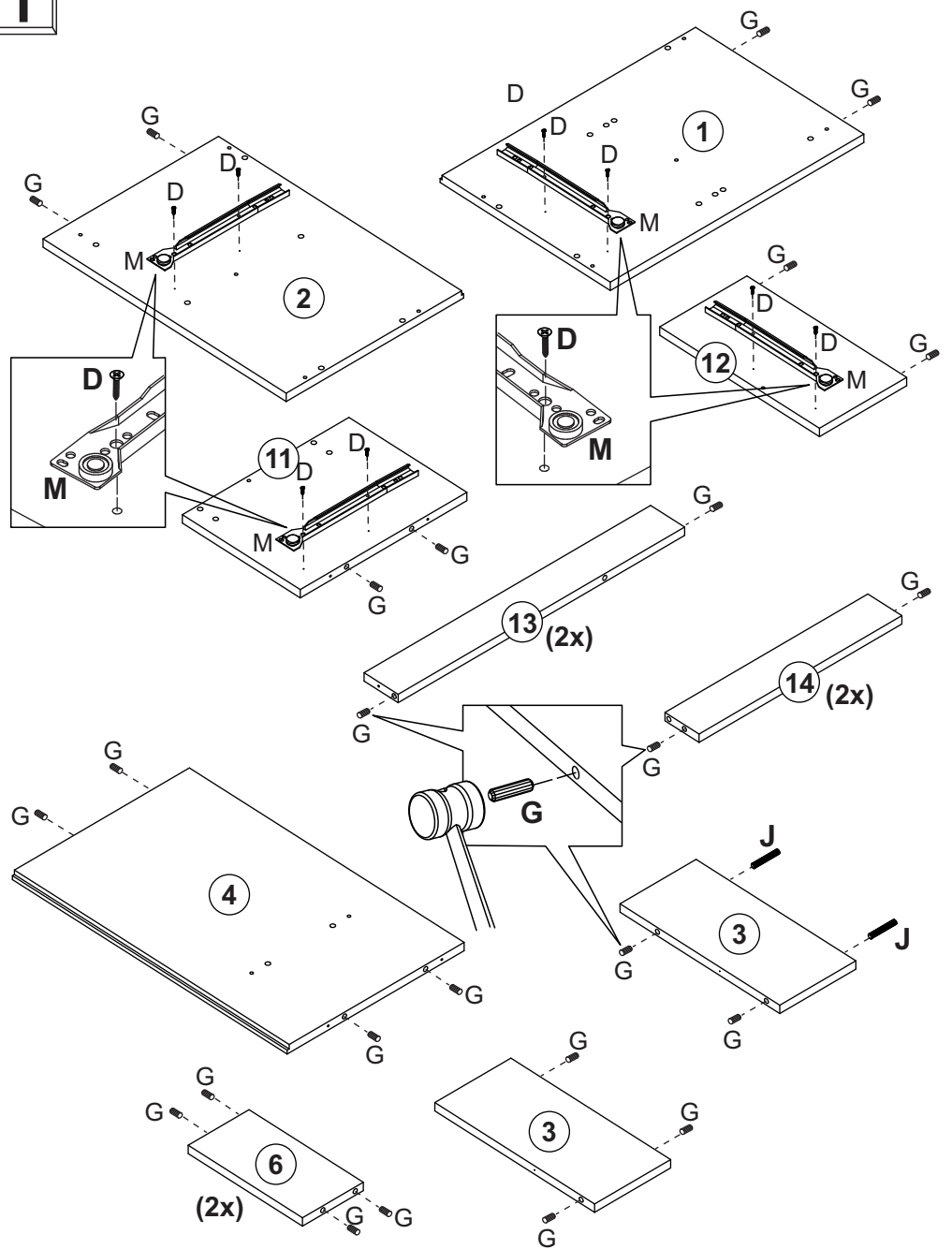
6**7****1**

2

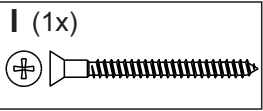
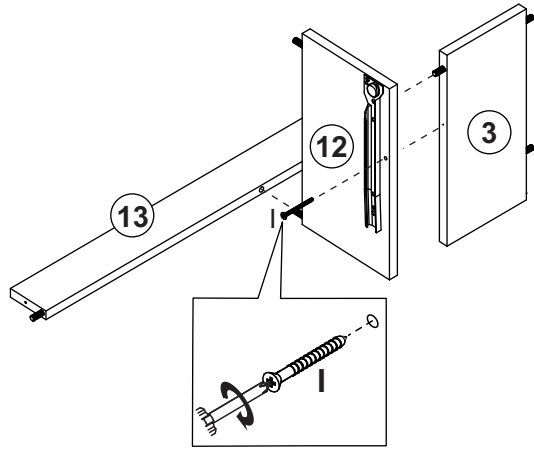

3

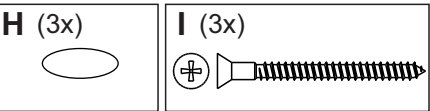
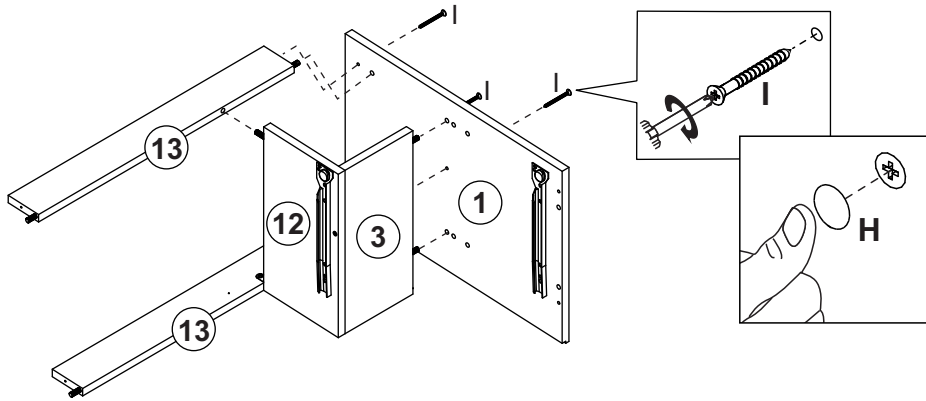

4

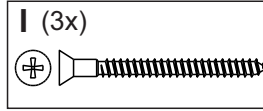
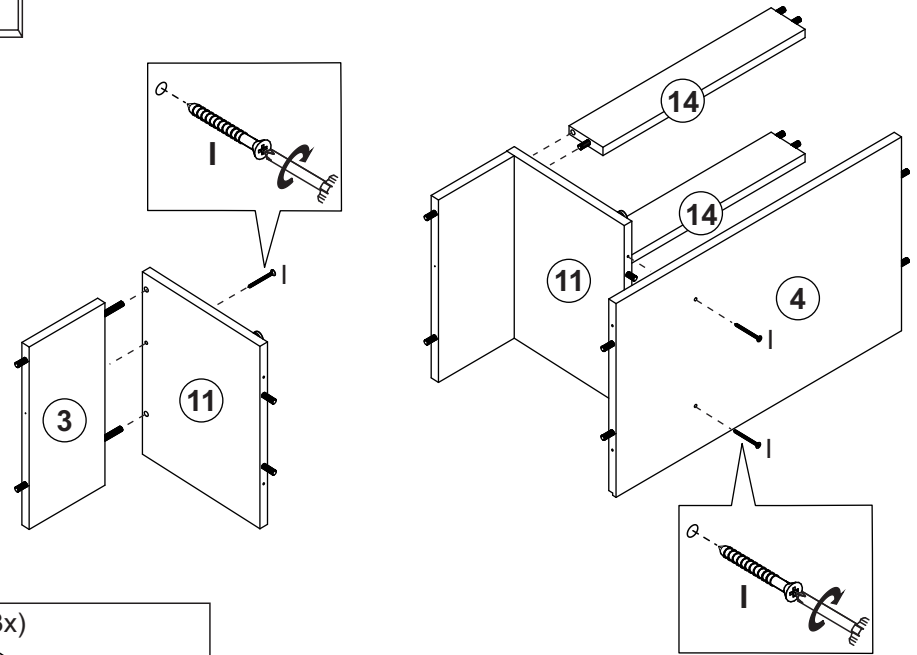

5

