

Fone (32) 3539-7600

Rod. Ubá - Rodeiro, Km 03 - Galpão 1

C. P 050 - CEP 36500-000 - Ubá - MG

E-mail: mavaular@mavaular.com.br - Site: www.mavaular.com.br



Instruções de Montagem Rack Arezzo

Arezzo Panel Room Assembly Instructions

Instrucciones de montaje del Panel Arezzo

CÓDIGO: 9883

✓ Atualizado em:
03/06/2022

CUIDE BEM DO SEU MÓVEL

Dicas de limpeza e conservação:

- Para limpar corretamente seu produto, use sempre um pano liso e **levemente** umedecido com água;
- Não se esqueça de enxugar o seu móvel! Ele não deve permanecer úmido, pois a água pode prejudicar o acabamento ou causar mofo na madeira;
- Não se recomenda o uso de produtos à base de amoníaco.
- Não utilize esponja de aço ou qualquer material que possa arranhar a superfície do produto durante a limpeza.
- Não utilize plásticos ou papéis coloridos para forrar seu móvel.
- Evite arrastar objetos em cima do móvel. Eles podem riscar e prejudicar o acabamento de seu móvel de
- O material dos seus móveis tem um tratamento contra fungos e cupins, mesmo assim, em ambientes infestados recomenda-se a dedetização antes de instalar a seu móvel;
- Tente evitar a exposição direta ao sol. Sugere-se utilização de cortinas para proteger seu móvel;

TAKING GOOD CARE OF YOUR FURNITURE

Cleaning and caring instructions:

- Wipe the wood furniture down with a moist cloth to properly clean the furniture.
- Do not forget to dry your furniture out. Humidity can damage the finish or create mould.
- Chemical products are not recommended;
- Never clean the furniture with scouring powders, steel scrubber pads or any other product which can scratch its surface.
- Furniture surfaces should not be covered with colored plastic or paper sheets.
- Avoid dragging objects on top of the furniture. They might scratch the finishing.
- Wood furniture are made of mould and termites resistant materials, however, it is recommended to use termiticides in infested places before installing the furniture.
- Avoid furniture exposure to direct Sun light. Drapers suggested.

CUIDE BIEN DE SU MUEBLE

Indicaciones de limpieza y conservación

- Para limpiar correctamente su muebles de madera, siempre use un paño húmedo.
- No se olvide de secar su muebles! No debe permanecer húmedo, pues el agua puede perjudicar el acabado o causar moho en la madera.
- No es recomendable utilizar productos con amoníaco.
- No utilizar esponjas de acero o cualquier material que dañe la superficie de los muebles.
- No utilizar plásticos o papeles coloridos para forrar los muebles.
- Evite arrastrar objetos encima de los muebles. Ellos pueden riscar o dañar el acabado de su mueble de cocina.
- El material de los muebles tiene un tratamiento contra los hongos y las polillas, aun así, en ambientes infectados, se recomienda desinfectar antes de instalar su mueble.
- Evite la exposición directa al sol. Se sugiere la utilización de cortinas para proteger sus muebles.

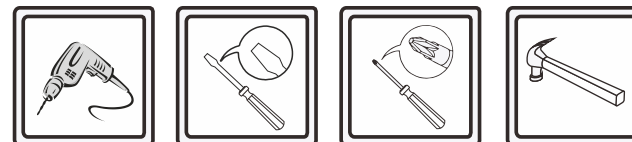
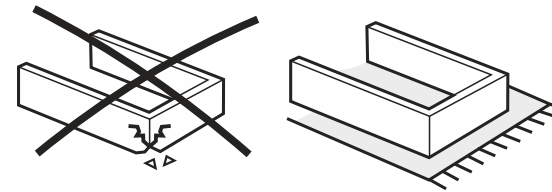
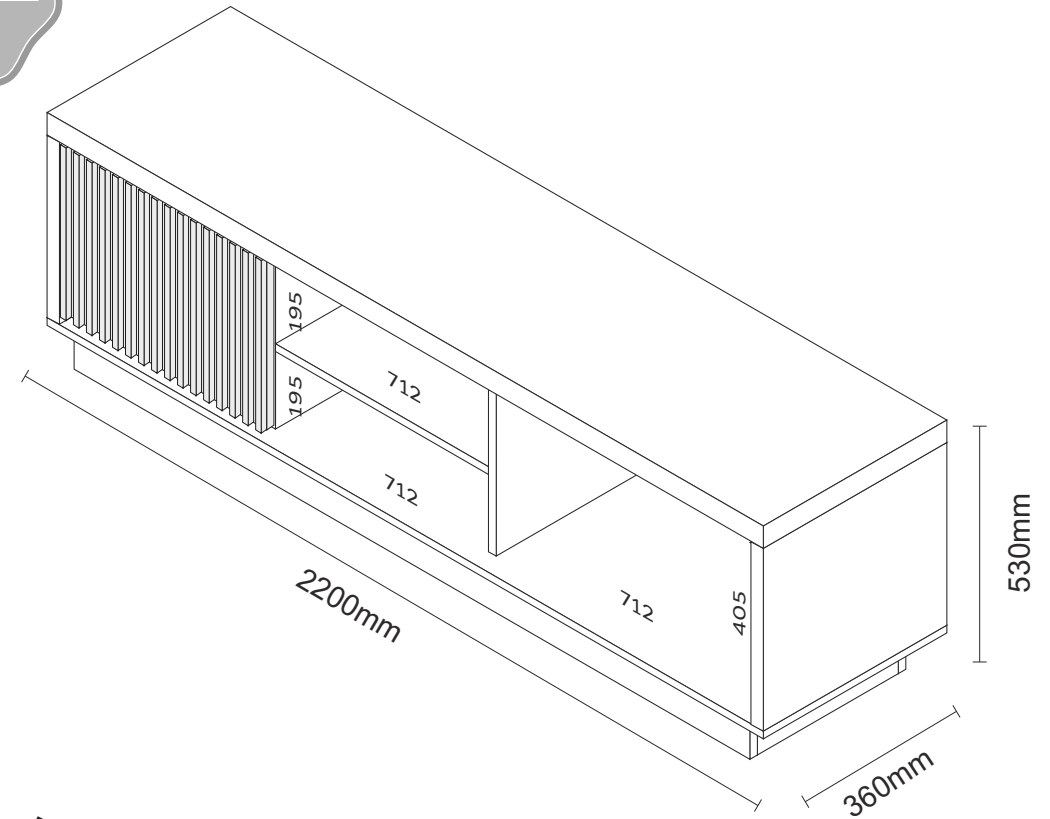













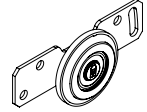
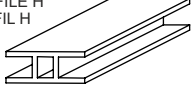

As ferramentas necessárias para montagem do produto não são fornecidas.

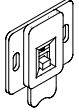
The necessary tools for assembly aren't supplied.

Las herramientas necesarias para armar los productos no son fornecidas.

N°	CÓDIGO CODE CÓDIGO	DESCRIÇÃO DESCRIPTION DESCRIPCIÓN			DIMENSÃO (mm) DIMENSION (mm) DIMENSIÓN (mm)			QUANTIDADE QUANTITY CANTIDAD
					COMP. LEN. LON.	LARG. WID. ANC.	EPS DEP ESP	
1	9728	Tampo	Cover	Cubrir	2200	360	40	1
2	9733	Lateral Direita / Esquerda	Right/Left Side	Lado derecho/izquierdo	405	355	15	2
3	9734	Divisão	Division	División	405	305	15	2
4	9735	Prateleira	Shelf	Estante	712	302	15	1
5	9732	Base	Basis	Base	2200	360	15	1
6	9739	Rodapé Lateral	Side Footer	Pie de página lateral	315	70	25	2
7	9738	Rodapé Interno	Internal footer	Pie de página interno	298	70	25	2
8	9737	Rodapé Traseiro	back footer	pie de página posterior	2099	70	15	1
9	9736	Rodapé Frontal	Front footer	Pie de página frontal	2152	70	15	1
10	9741	Costa Central	Central Coast	Costa central	727	218	2,5	2
11	9742	Costa Lateral Superior	Upper Side Coast	Costa lateral superior	732	100	2,5	2
12	9740	Costa Lateral Inferior	Lower Side Coast	Costa lateral inferior	732	331	2,5	2
13	9755	Porta	Door	Puerta	740	397	12	1

A - PARAFUSO 4X40MM 4X40MM SCREW TORNILLO 4X40MM 	x12	G - PREGO 10X10 NAIL 10X10 CLAVOS 10X10 	x40	M - PARAFUSO 3,5X14MM 3,5X14MM SCREW TORNILLO 3,5X14MM 	x08
B - CAVILHA MADEIRA 6X30MM 6X30MM WOODEN DOWEL TARUGO DE MADEIRA 6X30MM 	x08	H - TAPA FURO ADESIVO ADHESIVE HOLE COVER TAPA AGUJERO ADHESIVO 	x04	N - PARAFUSO 3,5X12MM 3,5X12MM SCREW TORNILLO 3,5X12MM 	x08
C - CONECTOR DE MONTAGEM MOUNTING CONNECTOR CONECTOR DE MONTAJE 	x16	I - ROLDANA PULLEY POLEA 	x02	O - PERFIL H PROFILE H PERFIL H 	x08
D - PARAFUSO 3,5X14MM 3,5X14MM SCREW TORNILLO 3,5X14MM 	x64	J - GUIA PORTA CORRER SLIDING DOOR GUIDE GUÍA PUERTA CORREDERA 	x02	P - TRILHO DE PLÁSTICO PLASTIC RAIL CARRIL DE PLÁSTICO 	x08
E - CAVILHA MADEIRA 8X30MM 8X30MM WOODEN DOWEL TARUGO DE MADEIRA 8X30MM 	x08	K - GARRA FUNDO DEEP CLAW GARRA PROFUNDA 	x12		
F - SAPATA REDONDA ROUND SHOE ZAPATO REDONDO 	x08	L - BATENTE DE SILICONE SILICON STOP TOPE DE SILICIO 	x04		

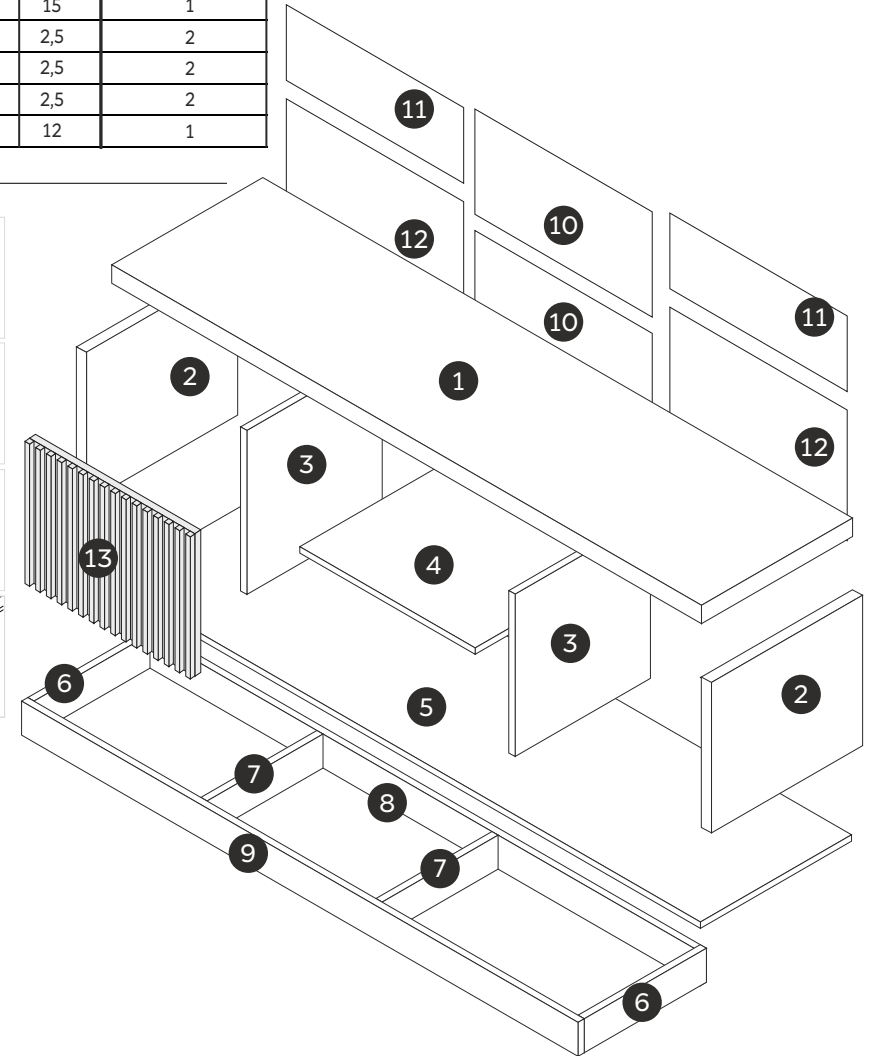

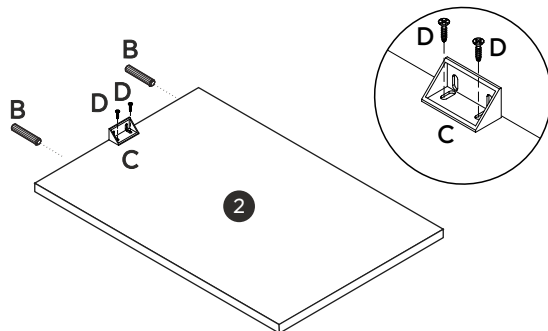
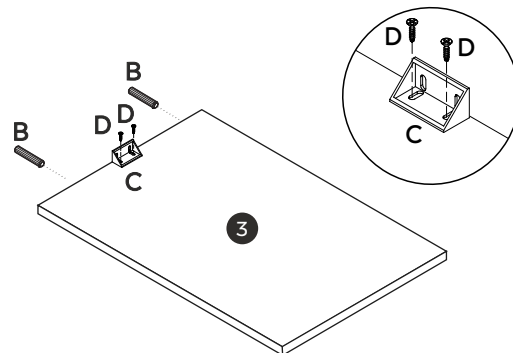
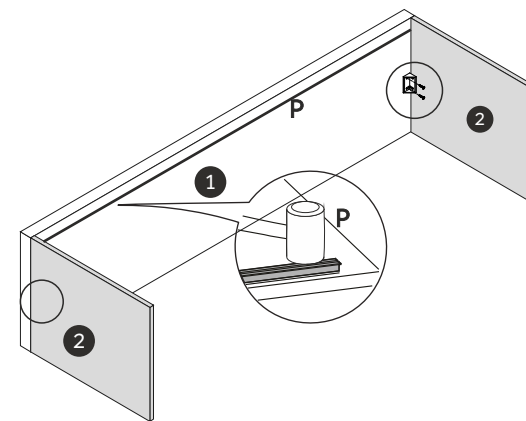
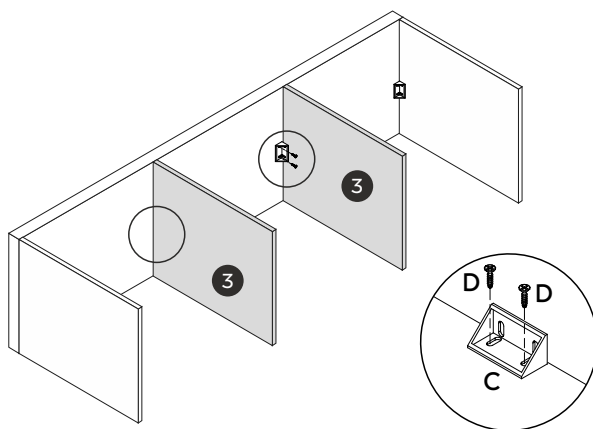
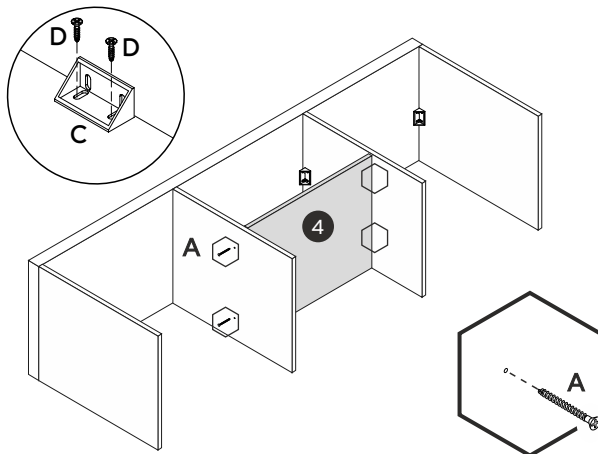
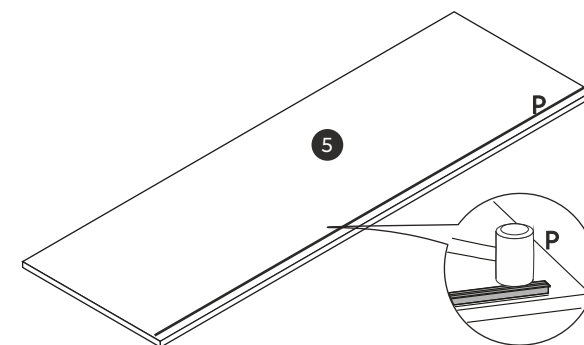
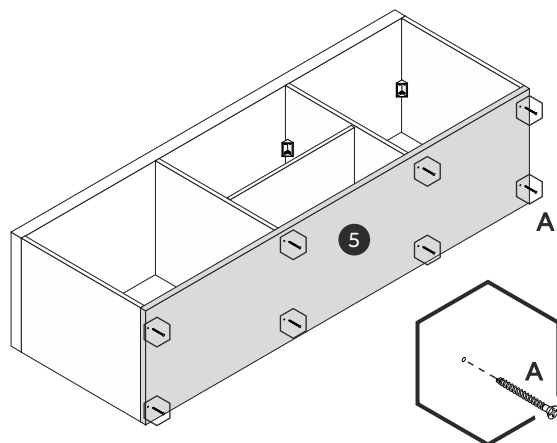
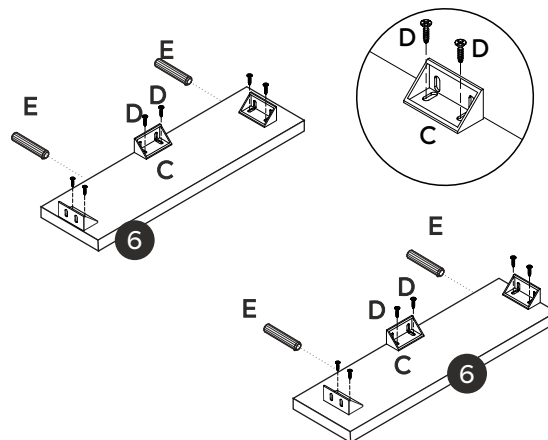
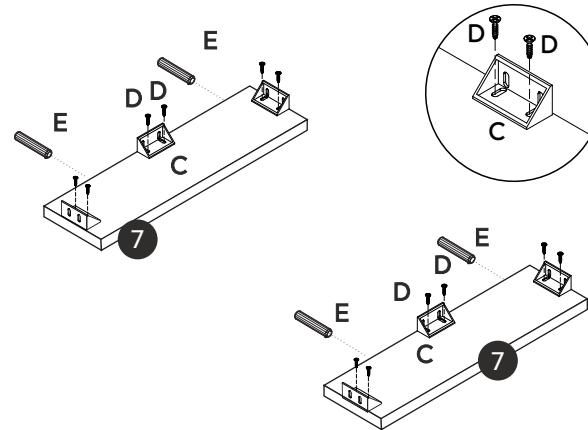
1**2****3****4****5****6****7****8****9**

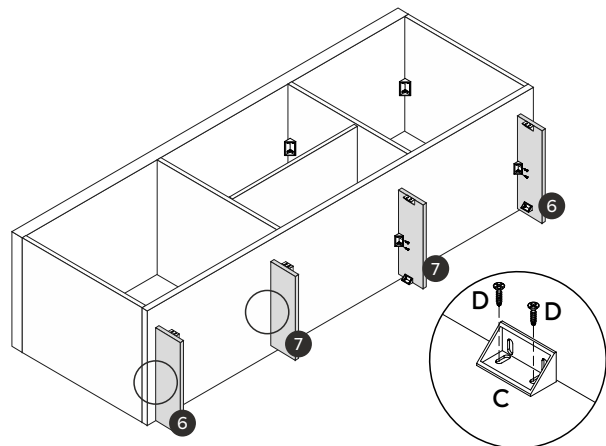
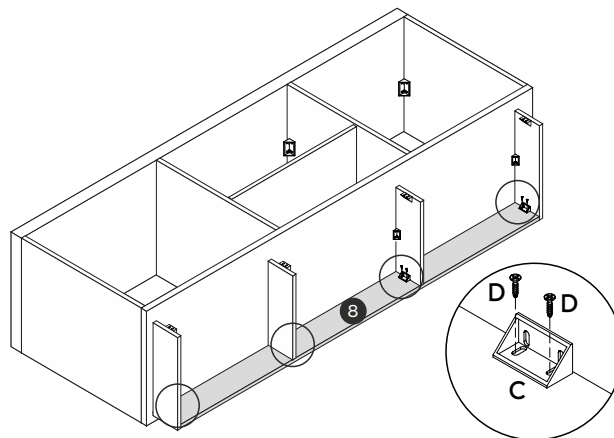
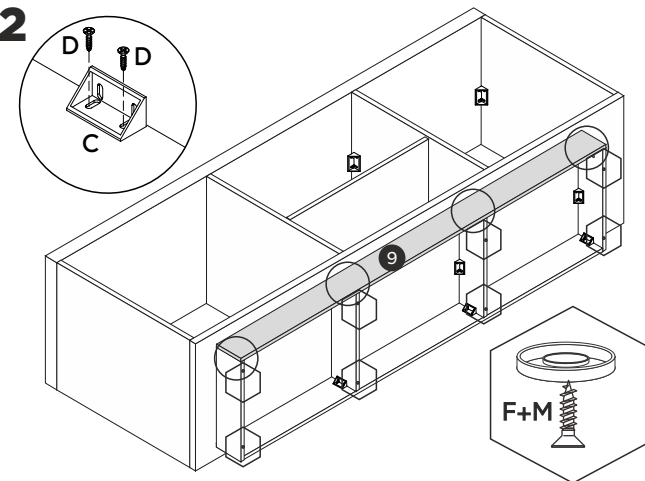
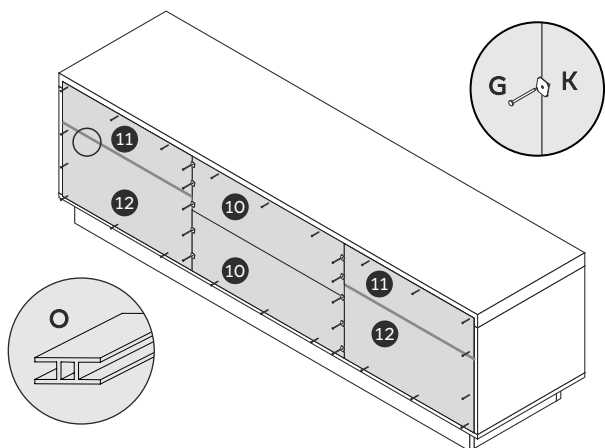
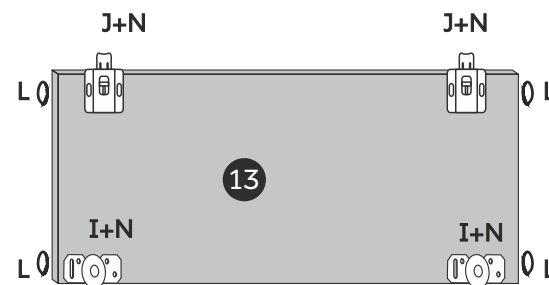
10**11****12****13****14**

Importante: para colar o batente da porta, remova a proteção e cole na porta
Important: to glue the door frame, remove the protection and glue it to the door
Importante: para pegar el marco de la puerta, quitar la protección y pegarla a la puerta

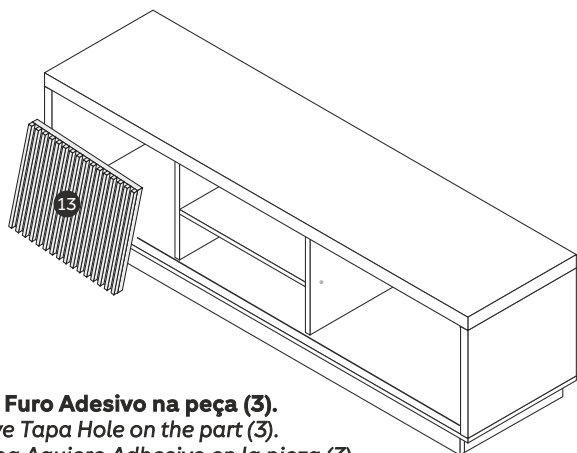
15

Importante: Usa Tapa Furo Adesivo na peça (3).
Important: Use Adhesive Tapa Hole on the part (3).
Importante: Utilizar Tapa Agujero Adhesivo en la pieza (3).

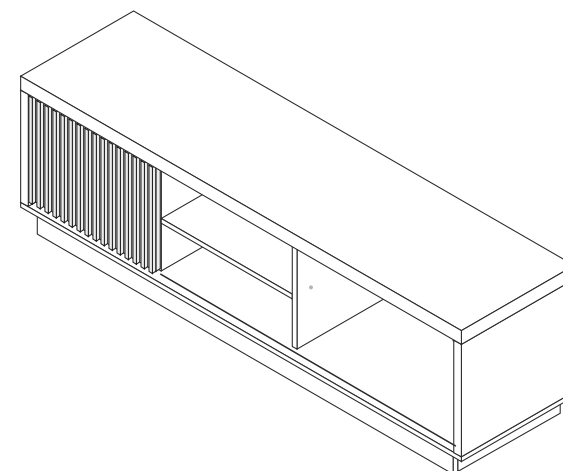
16



MAVAULAR móveis

Fone (32) 3539-7600

Rod. Ubá - Rodeiro, Km 03 - Galpão 1

C. P. 050 - CEP 36500-000 - Ubá - MG

E-mail: mavaular@mavaular.com.br - Site: www.mavaular.com.br

f@ Mavaular Móveis



Instruções de Montagem Painel Arezzo New

Arezzo Panel New Room Assembly Instructions

Instrucciones de montaje del Panel Arezzo New

CÓDIGO: 9913

Atualizado em:
30/01/2025

CUIDE BEM DO SEU MÓVEL

Dicas de limpeza e conservação:

- Para limpar corretamente seu produto, use sempre um pano liso e **levemente** umedecido com água;
- Não se esqueça de enxugar o seu móvel! Ele não deve permanecer úmido, pois a água pode prejudicar o acabamento ou causar mofo na madeira;
- Não se recomenda o uso de produtos à base de amoníaco.
- Não utilize esponja de aço ou qualquer material que possa arranhar a superfície do produto durante a limpeza.
- Não utilize plásticos ou papéis coloridos para forrar seu móvel.
- Evite arrastar objetos em cima do móvel. Eles podem riscar e prejudicar o acabamento de seu móvel de
- O material dos seus móveis tem um tratamento contra fungos e cupins, mesmo assim, em ambientes infestados recomenda-se a dedetização antes de instalar a seu móvel;
- Tente evitar a exposição direta ao sol. Sugere-se utilização de cortinas para proteger seu móvel;

TAKING GOOD CARE OF YOUR FURNITURE

Cleaning and caring instructions:

- Wipe the wood furniture down with a moist cloth to properly clean the furniture.
- Do not forget to dry your furniture out. Humidity can damage the finish or create mould.
- Chemical products are not recommended;
- Never clean the furniture with scouring powders, steel scrubber pads or any other product which can scratch its surface.
- Furniture surfaces should not be covered with colored plastic or paper sheets.
- Avoid dragging objects on top of the furniture. They might scratch the finishing.
- Wood furniture are made of mould and termites resistant materials, however, it is recommended to use termiticides in infested places before installing the furniture.
- Avoid furniture exposure to direct Sun light. Drapers suggested.

CUIDE BIEN DE SU MUEBLE

Indicaciones de limpieza y conservación

- Para limpiar correctamente su muebles de madera, siempre use un paño húmedo.
- No se olvide de secar su muebles! No debe permanecer húmedo, pues el agua puede perjudicar el acabado o causar moho en la madera.
- No es recomendable utilizar productos con amoníaco.
- No utilizar esponjas de acero o cualquier material que dañe la superficie de los muebles.
- No utilizar plásticos o papeles coloridos para forrar los muebles.
- Evite arrastrar objetos encima de los muebles. Ellos pueden riscar o dañar el acabado de su mueble de cocina.
- El material de los muebles tiene un tratamiento contra los hongos y las polillas, aun así, en ambientes infectados, se recomienda desinfectar antes de instalar su mueble.
- Evite la exposición directa al sol. Se sugiere la utilización de cortinas para proteger sus muebles.

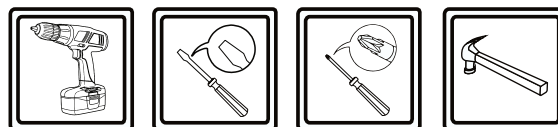
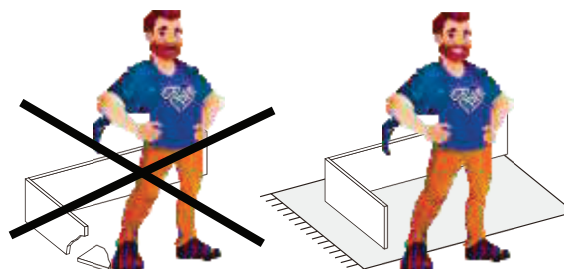
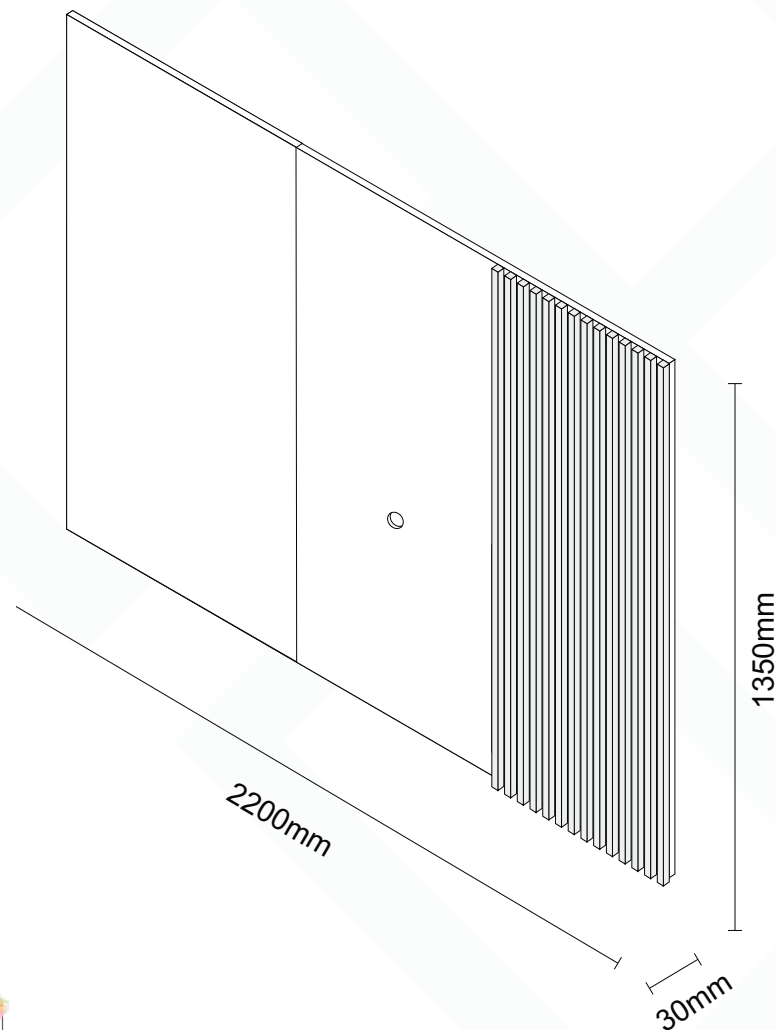

As ferramentas necessárias para montagem do produto não são fornecidas.
The necessary tools for assembly aren't supplied.

Las herramientas necesarias para armar los productos no son fornecidas.

N°	CÓDIGO CODE CÓDIGO	DESCRIÇÃO DESCRIPTION DESCRIPCIÓN	DIMENSÃO (mm) DIMENSION (mm) DIMENSIÓN (mm)			QUANTIDADE QUANTITY CANTIDAD		
			COMP. LEN. LON.	LARG. WID. ANC.	EPS DEP ESP			
1	14632	Painel Lateral Liso Painel Arezzo New	Smooth Side Panel Arezzo New Panel	Panel Lateral Liso Arezzo Nuevo Panel	1350	875	15	1
2	14633	Painel Central Painel Arezzo New	Central Panel Arezzo New Panel	Panel Central Arezzo Nuevo Panel	1350	875	15	1
3	14710	Painel Ripado Direito Painel Arezzo New	Rip Panel Arezzo New Panel	Panel Rip Arezzo Panel Nuevo	1350	450	30	1
4	14635	Moldura Superior Painel Arezzo New	Top Frame Arezzo New Panel	Marco Superior Arezzo Nuevo Panel	1350	70	15	1
5	14636	Moldura Lateral Painel Arezzo New	Arezzo New Panel Side Frame	Marco lateral del nuevo panel Arezzo	1320	70	15	2
6	14637	Moldura Inferior Painel Arezzo New	Arezzo New Panel Lower Frame	Marco inferior del panel nuevo Arezzo	600	70	15	1
7	14638	Moldura de União Painel Arezzo New	Arezzo New Panel Union Frame	Marco de unión de paneles nuevos Arezzo	900	120	15	1
8	14639	Moldura Painel Ripado Painel Arezzo New	Ripado Panel Frame Arezzo New Panel	Marco Panel Ripado Arezzo Panel Nuevo	350	70	15	2
9	14640	Moldura Parede Painel Ripado Arezzo New	Arezzo New Ripado Panel Wall Frame	Marco de pared con panel Arezzo New Ripado	350	70	15	2
10	14641	Moldura Parede Painel Arezzo New	Arezzo New Panel Wall Frame	Marco de pared de panel nuevo Arezzo	1300	70	15	1
11	14887	Fechamento Lateral DIR Painel Arezzo New	Arezzo New Left Panel Side Closure	Arezzo Nuevo izquierdo Panel Cierre Lateral	1350	16	15	1
12	15465	Fechamento Lateral ESQ Painel Arezzo New	Arezzo New Rig Panel Side Closure	Arezzo Nuevo Derecho Panel Cierre Lateral	1350	16	15	1
13	15503	Moldura Parede Menor Painel Arezzo New	Arezzo New Panel Wall Frame	Marco de pared de panel nuevo Arezzo	600	70	15	1

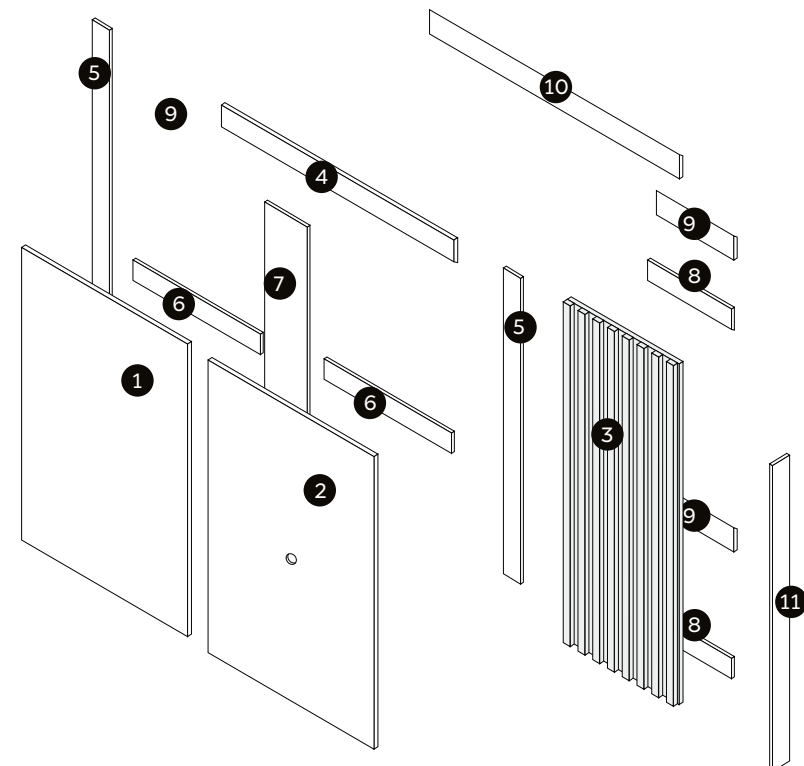
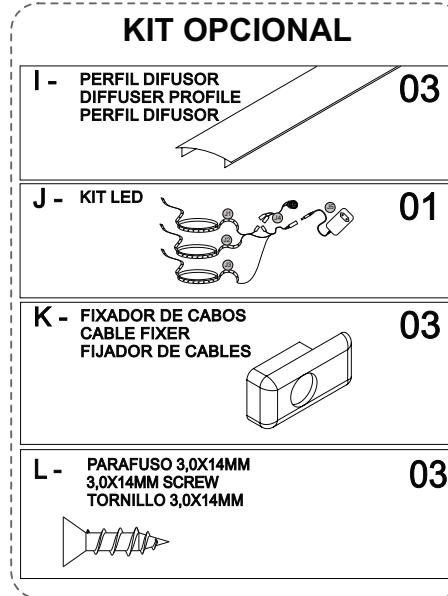
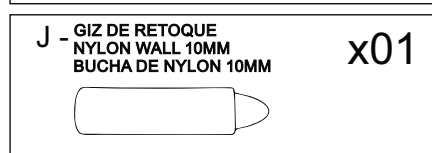
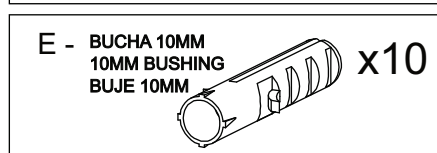
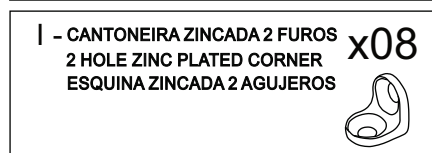
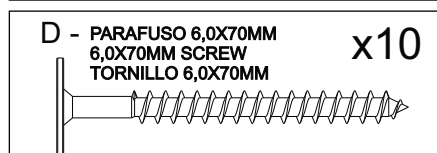
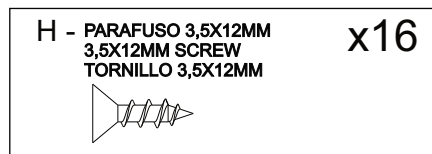
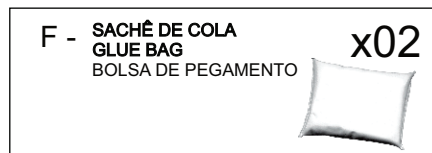

1

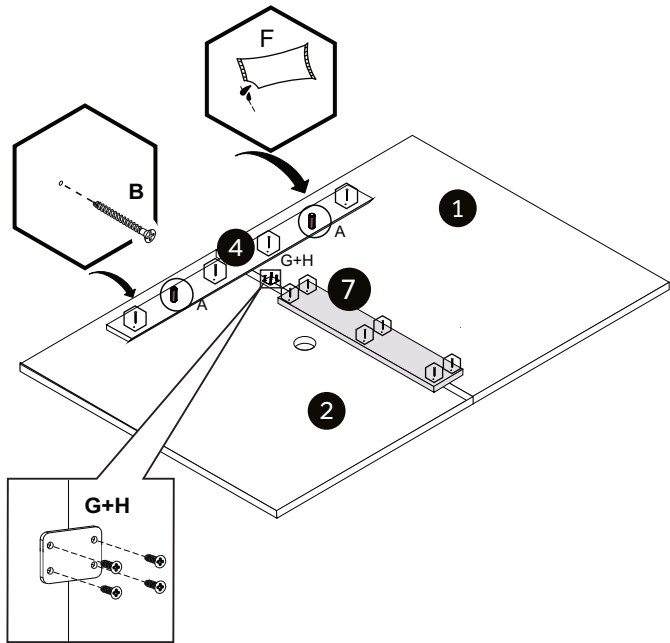

2

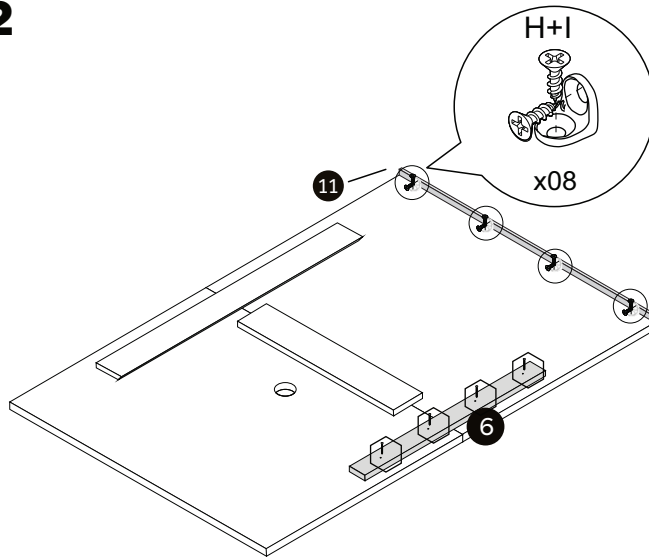

3

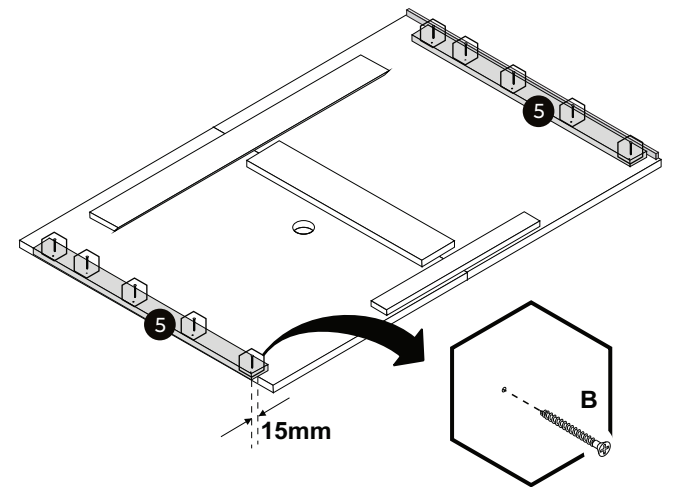

4

KIT LED OPCIONAL

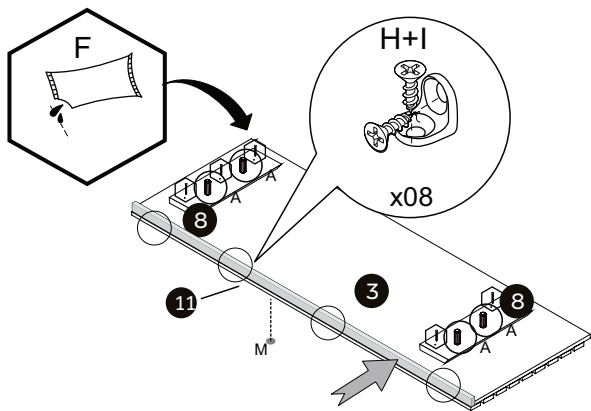

5

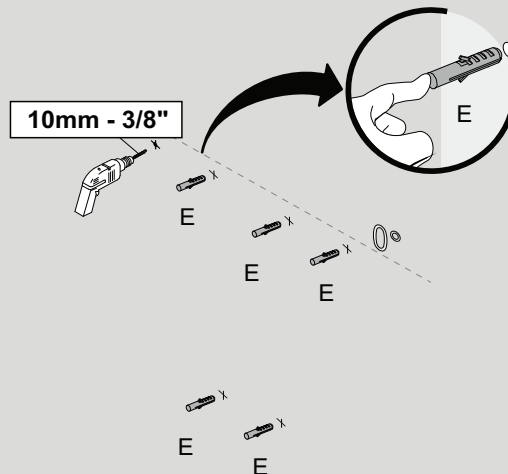

6

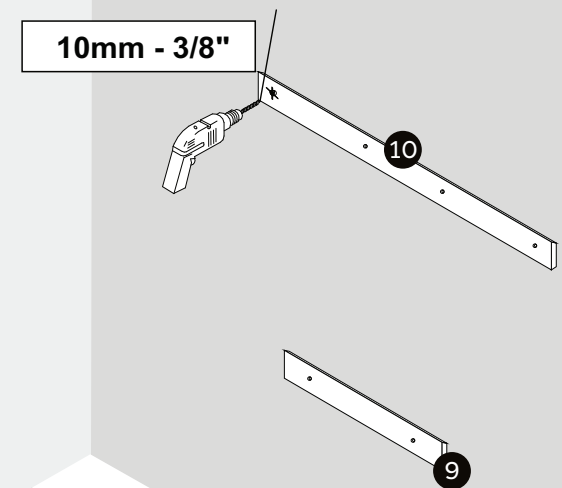

7

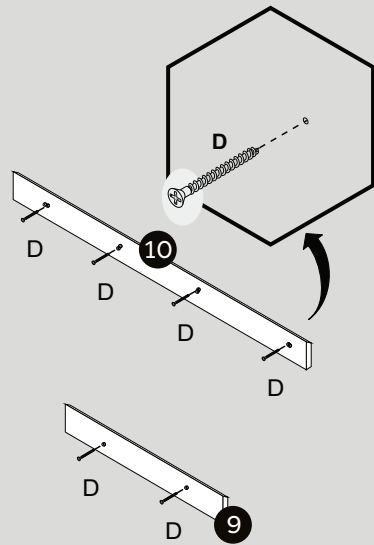

8

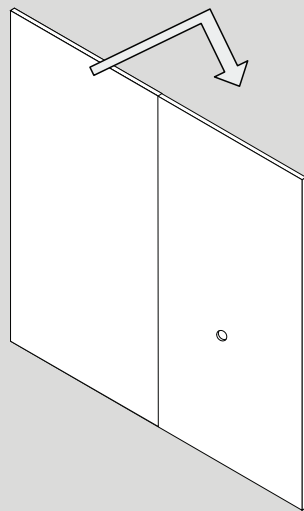

9

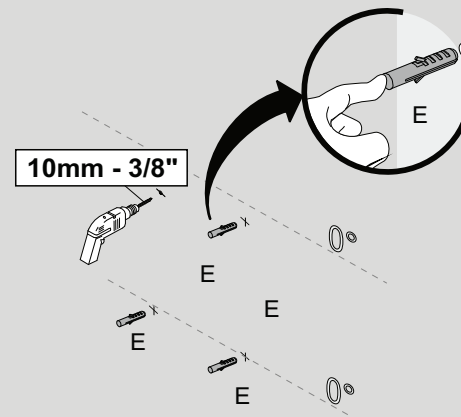

10

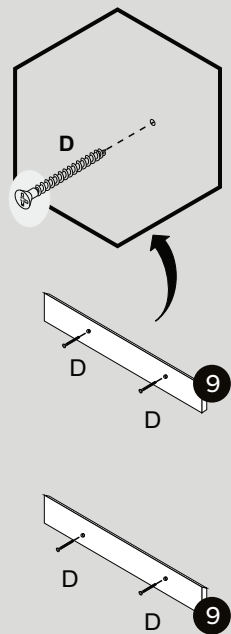

11

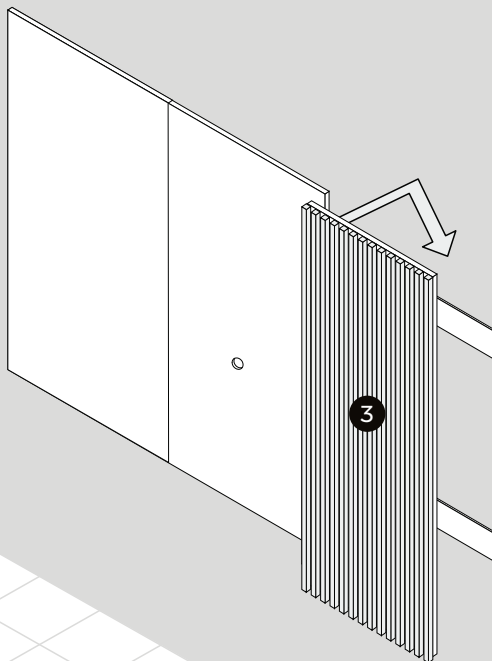

12

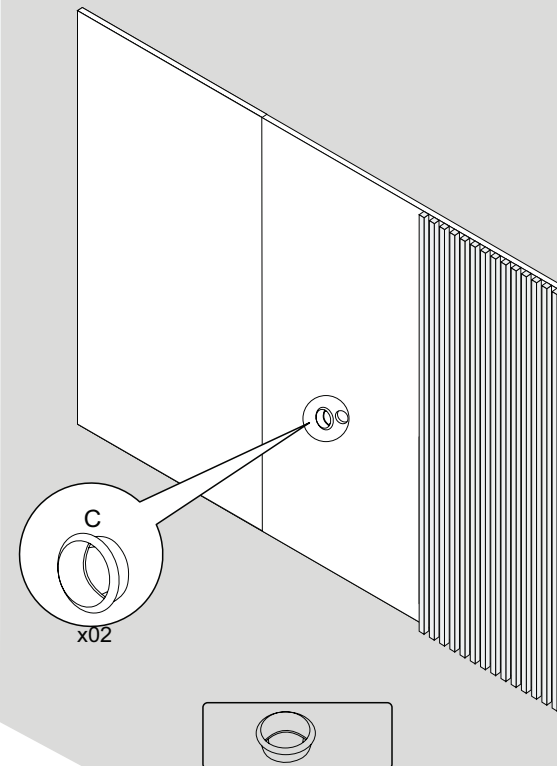



MAVAULAR móveis

Fone (32) 3539-7600

Rod. Ubá - Rodeiro, Km 03 - Galpão 1
C. P. 050 - CEP 36500-000 - Ubá - MG
E-mail: mavaular@mavaular.com.br - Site: www.mavaular.com.br

Mavaular Móveis



Instruções de Montagem Cristaleira Dominus

Assembly Instructions for the Dominus Display Cabinet

Instrucciones de montaje de la vitrina Dominus

CÓDIGO: 17534

Atualizado em:
28/01/2026

CUIDE BEM DO SEU MÓVEL

Dicas de limpeza e conservação:

- Para limpar corretamente seu produto, use sempre um pano liso e **levemente** umedecido com água;
- Não se esqueça de enxugar o seu móvel! Ele não deve permanecer úmido, pois a água pode prejudicar o acabamento ou causar mofo na madeira;
- Não se recomenda o uso de produtos à base de amoníaco.
- Não utilize esponja de aço ou qualquer material que possa arranhar a superfície do produto durante a limpeza.
- Não utilize plásticos ou papéis coloridos para forrar seu móvel.
- Evite arrastar objetos em cima do móvel. Eles podem riscar e prejudicar o acabamento de seu móvel de
- O material dos seus móveis tem um tratamento contra fungos e cupins, mesmo assim, em ambientes infestados recomenda-se a dedetização antes de instalar a seu móvel;
- Tente evitar a exposição direta ao sol. Sugere-se utilização de cortinas para proteger seu móvel;

TAKING GOOD CARE OF YOUR FURNITURE

Cleaning and caring instructions:

- Wipe the wood furniture down with a moist cloth to properly clean the furniture.
- Do not forget to dry your furniture out. Humidity can damage the finish or create mould.
- Chemical products are not recommended;
- Never clean the furniture with scouring powders, steel scrubber pads or any other product which can scratch its surface.
- Furniture surfaces should not be covered with colored plastic or paper sheets.
- Avoid dragging objects on top of the furniture. They might scratch the finishing.
- Wood furniture are made of mould and termites resistant materials, however, it is recommended to use termiticides in infested places before installing the furniture.
- Avoid furniture exposure to direct Sun light. Drapers suggested.

CUIDE BIEN DE SU MUEBLE

Indicaciones de limpieza y conservación

- Para limpiar correctamente su muebles de madera, siempre use un paño húmedo.
- No se olvide de secar su muebles! No debe permanecer húmedo, pues el agua puede perjudicar el acabado o causar moho en la madera.
- No es recomendable utilizar productos con amoníaco.
- No utilizar esponjas de acero o cualquier material que dañe la superficie de los muebles.
- No utilizar plásticos o papeles coloridos para forrar los muebles.
- Evite arrastrar objetos encima de los muebles. Ellos pueden riscar o dañar el acabado de su mueble de cocina.
- El material de los muebles tiene un tratamiento contra los hongos y las polillas, aun así, en ambientes infectados, se recomienda desinfectar antes de instalar su mueble.
- Evite la exposición directa al sol. Se sugiere la utilización de cortinas para proteger sus muebles.

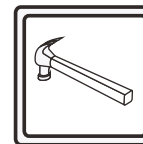
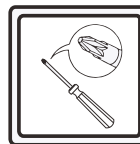
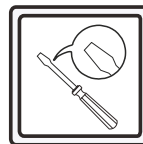
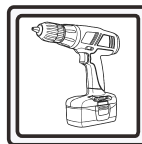
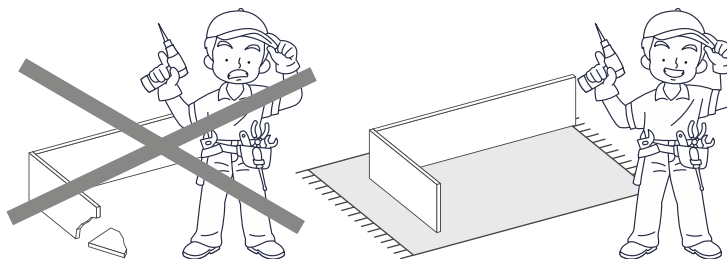
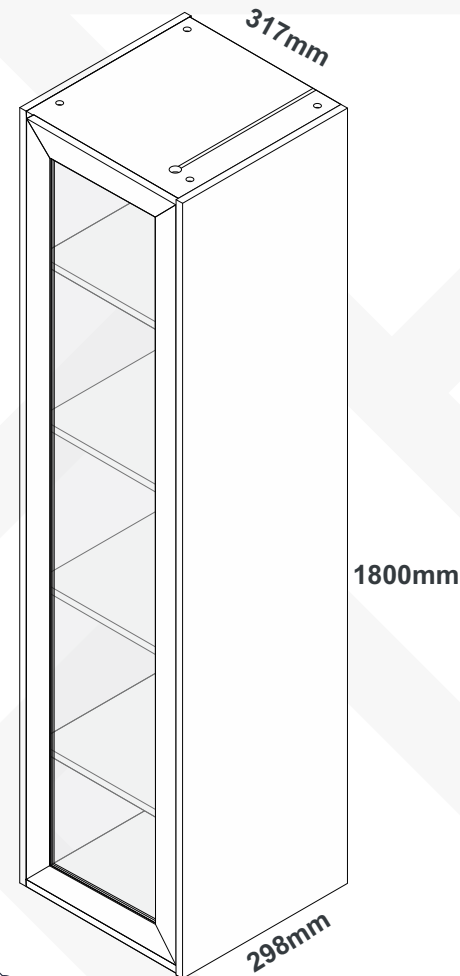

As ferramentas necessárias para montagem do produto não são fornecidas.
The necessary tools for assembly aren't supplied.
Las herramientas necesarias para armar los productos no son fornecidas.

N°	CÓDIGO CODE CÓDIGO	DESCRIÇÃO DESCRIPTION DESCRIPCIÓN	DIMENSÃO (mm) DIMENSION (mm) DIMENSIÓN (mm)			QUANTIDADE QUANTITY CANTIDAD		
			COMP. LEN. LON.	LARG. WID. ANC.	EPS DEP ESP			
1	17255	Lateral Esquerda	Left Side Panel	Panel lateral izquierdo	1800	298	15	1
2	17256	Lateral Direita	Right Side Panel	Panel lateral derecho	1800	298	15	1
3	17257	Tampo	Top Panel	Panel superior	336	287	15	1
4	17258	Base	Base Panel	Panel base	336	287	15	1
5	17263	Painel Traseiro	Back Panel	Panel trasero	1766	336	15	1
6	17259	Prateleira	Shelf	Estante	336	248	15	4
7	17260	Moldura Painel	Panel Frame	Marco del panel	325	70	15	3
8	17261	Moldura Parede	Wall Frame	Marco de pared	325	70	15	3
9	17151	Porta	Door	Puerta	1800	370	20	1

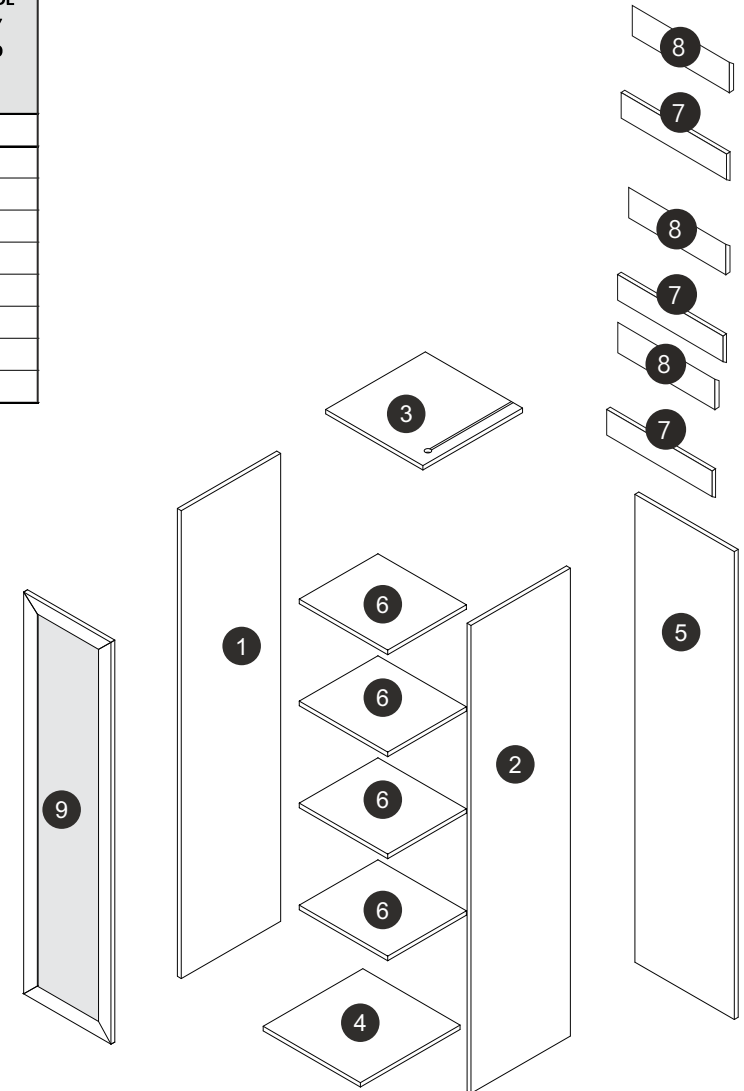
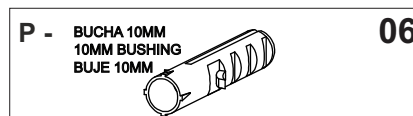
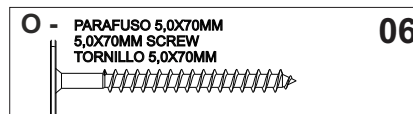
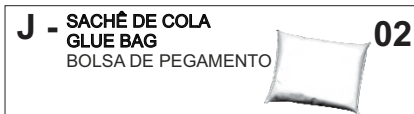
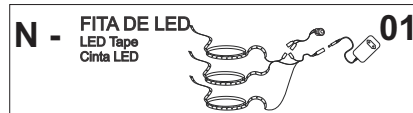
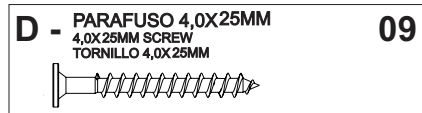
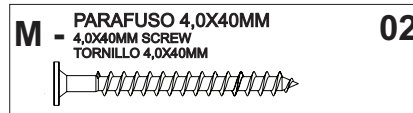
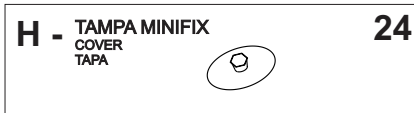
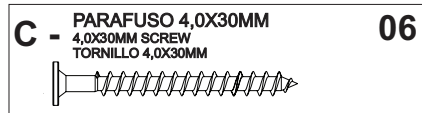
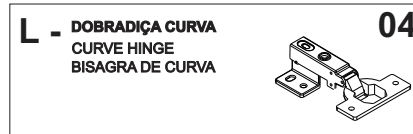
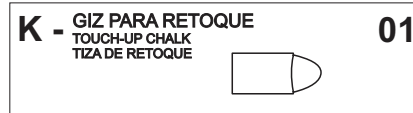
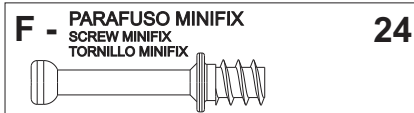

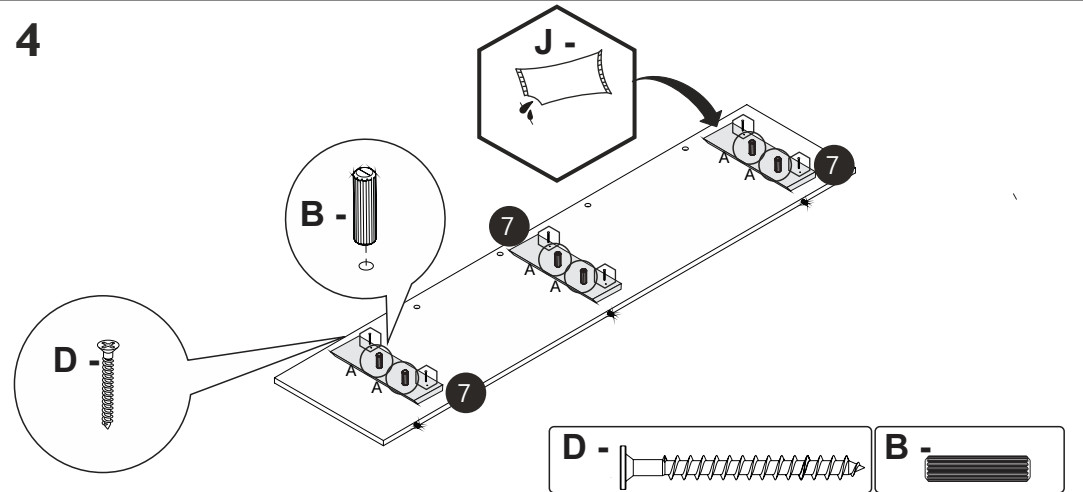
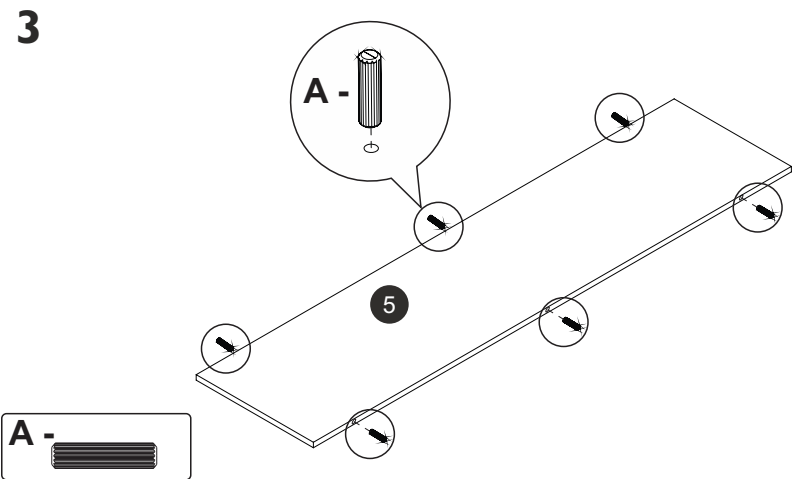
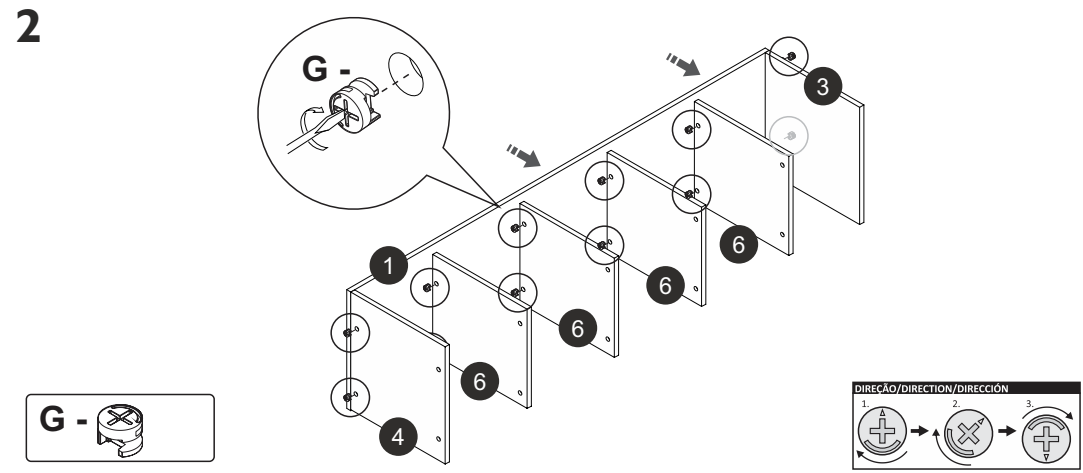
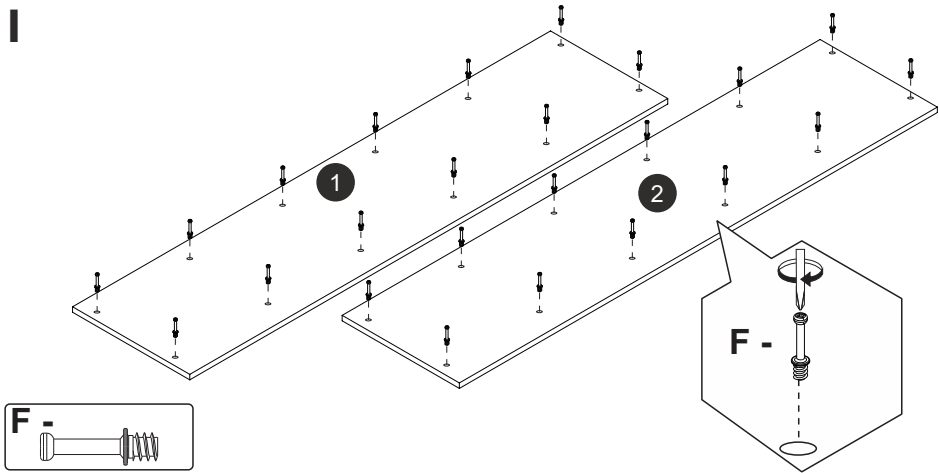

5 MONTAR KIT LED.
FIXAR AS FITAS DE LED ATRÁS DAS
PRATELEIRAS INDICADAS ABAIXO.

