

- 3103-PORTA DIREITA
- 3104-PORTA ESQUERDA
- 3105-LATERAL DIREITA
- 3106-LATERAL ESQUERDA
- 3107-TAMPO
- 3108-RODAPÉ
- 3109-BASE
- 3110-PRATELEIRA
- 3111-COSTA MAIOR
- 3112-COSTA MENOR

“OBS; Para solicitar assistência técnica, utilize o código da peça indicada.”

	Cód.	FERRAGEM	QTDE.
A	2592	ZINCADO BRANCO 4,0x40	06
A	4042	ZINCADO PRETO 4,0x40	06
B	4214	3,5x14	17
C	4206	3,5x14	16
D	4206		04
E	4206		04
F	1737		04
G	5710		02
I	1802		16
J	107	10x10	23
L	14773	3,5x25	04
M	1620		01
N	1621		01
□	1622		01
P	41		01
Q	1178	3,5x16	04
R	85		02
S	1736		04
T	58		01

“OBS; Para solicitar assistência técnica, utilize o código da ferragem indicada.”

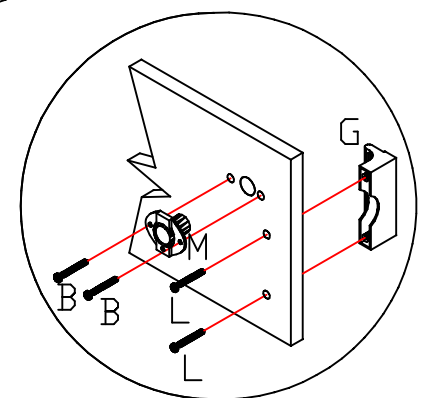

DETALHE DE COMO FIXAR O PUXADOR E A FECHADURA.

“GARANTIA PARA DEFEITOS DE FABRICAÇÃO DE 03 MESES

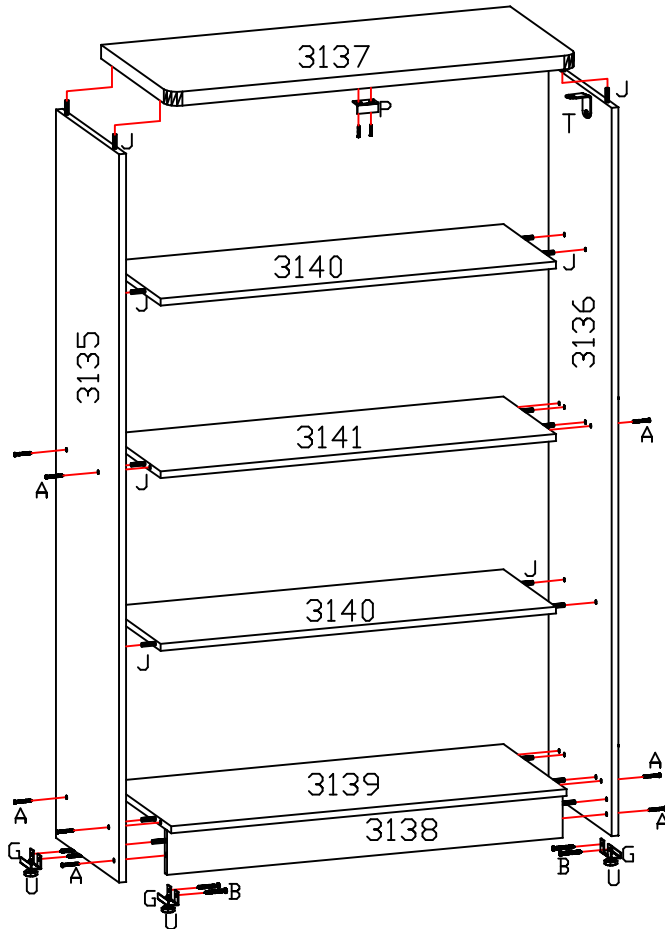

FIXE O BATENTE PRÓXIMO A BORDA DO CHAPÉU PARA FACILITAR O TRAVAMENTO DAS PORTAS.

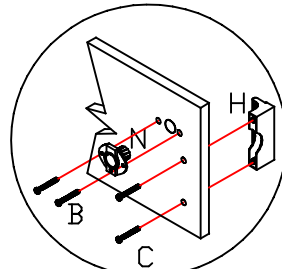
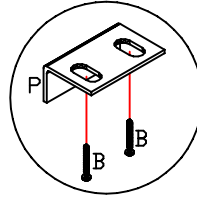

DETALHE DE COMO FIXAR O PUXADOR E A FECHADURA.

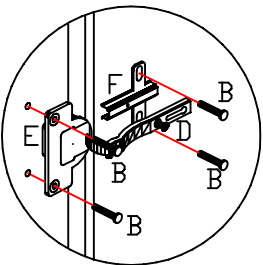
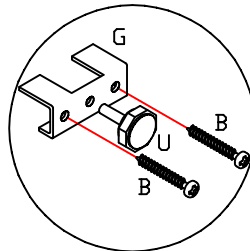

- 3133-PORTA ESQUERDA
- 3134-PORTA DIREITA
- 3135-LATERAL ESQUERDA
- 3136-LATERAL DIREITA
- 3137-CHAPÉU
- 3138-RODAPÉ
- 3139-BASE
- 3140-PRATELEIRA
- 3141-PRATELEIRA FIXA
- 3142-FUNDO

← "OBS: Para solicitar assistência técnica, utilize o código da peça indicada."

3142

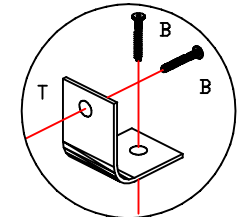
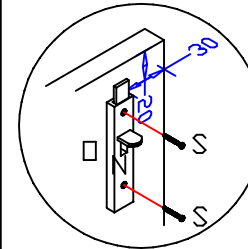
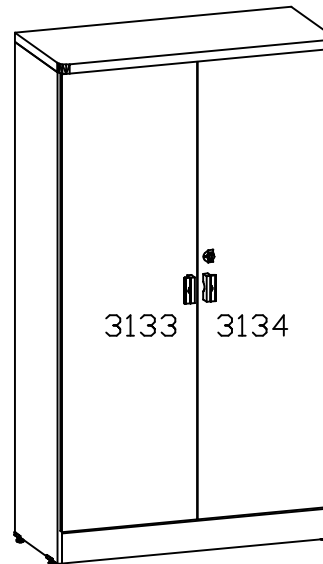
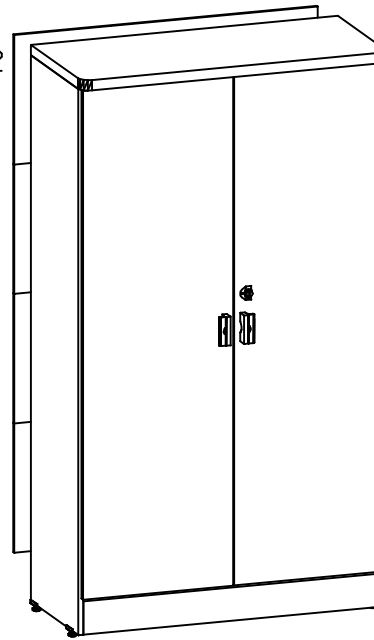

	C6D.	FERRAGEM	QTDE.
A	2592	ZINCADO BRANCO 4,0x40	10
A	4042	ZINCADO PRETO 4,0x40	10
B	4214	3,5X14	17
C	14773	3,5x25	04
D	4207	3,0x14	04
E	4207		06
F	4207		06
G	1737		04
H	5710		02
J	1802		25
L	107	10x10	65
N	1620		01
Q	1621		01
P	1622		01
Q	41		01
R	1423		28
S	1178	3,5x16	04
T	85		02
U	1736		04
V	58	kappesberg	01

"OBS: Para solicitar assistência técnica, utilize o código da ferragem indicada."

"GARANTIA PARA DEFEITOS DE FABRICAÇÃO DE 03 MESES."

# kappesberg

Ferramentas necessárias para montar o móvel  
Herramientas necesarias para armar el mueble.  
Tools needed to assemble the furniture.

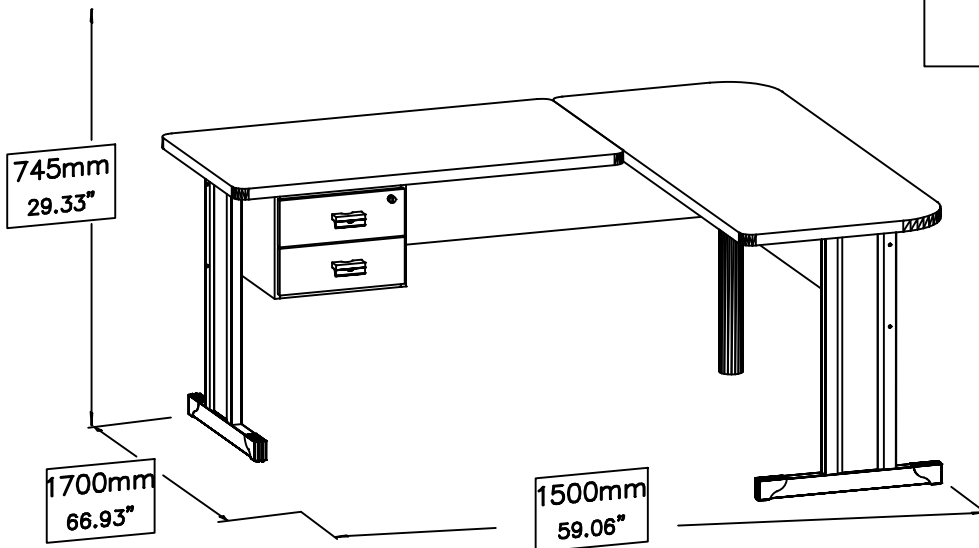

A montagem deve ser efetuada por **DUAS** pessoas.  
El montaje debe ser efectuado por **DOS** personas.  
The assembly must be done by **TWO** people.

Montar o móvel sobre uma superfície limpa e plana  
Armar el mueble sobre una superficie limpia y plana  
Assemble the furniture on a clean and flat surface

Lista de peças / Lista de piezas / List of pieces

Código / Code	Descrição	Descripción	Description	Quantidade / Cantidad / Amount	Comprimento / Longitud / Length (mm)	Comprimento / Longitud / Length (In.)	Largura / Ancho / Width (mm)	Largura / Ancho / Width (In.)	Espessura / Espesor / Thickness (mm)	Espessura / Espesor / Thickness (In.)	Caixa / Caja / Box
4508	Lateral esquerda	Lateral izquierda	Left side	1	291	11.46"	397	15.63"	15	.59"	A
4509	Lateral direita	Lateral derecha	Right side	1	291	11.46"	397	15.63"	15	.59"	A
4510	Frente de gaveta superior	Frente del cajón superior	Top drawer front	1	352	13.86"	128	5.04"	15	.59"	A
4511	Sarrafo sup. das gavetas	Marco superior de los cajones	Upper slat of drawers	1	340	13.39"	64	2.52"	15	.59"	A
4512	Lateral de gaveta	Lateral de cajón	Side drawer	4	360	14.17"	89	3.50"	15	.59"	A
4513	Cabeceira de gaveta	Cabecera de cajón	Back drawer	2	285	11.22"	89	3.50"	15	.59"	A
4514	Fundo de gaveta	Fondo de cajón	Bottom drawer	2	358	14.09"	298	11.73"	15	.59"	A
4515	Reforço fixação	Listón de fijación	Fixing batten	1	340	13.39"	64	2.52"	15	.59"	A
4516	Sarrafo inf. das gavetas	Marco inferior de los cajones	Lower slat of drawers	1	340	13.39"	64	2.52"	15	.59"	A
4519	Reforço maior	Mayor refuerzo	Greater reinforcement	1	1385	54.53"	293	11.54"	15	.59"	A
4520	Reforço menor	Refuerzo menor	Minor reinforcement	1	1186	46.69"	293	11.54"	15	.59"	A
4521	Tampo maior	Top más grande	Bigger top	1	1496	58.90"	596	23.46"	15	.59"	A
4522	Tampo menor	Top más pequeña	Lower Top	1	1096	43.15"	596	23.46"	15	.59"	A
4523	Laterais	Laterales	Sides	2	675	26.57"	128	5.04"	15	.59"	A
4524	Apoio dos tampo	Soporte de cap	Cap Support	2	64	2.52"	64	2.52"	15	.59"	A
4525	Frente de gaveta inferior	Frente del cajón inferior	Lower drawer front	1	352	13.86"	128	5.04"	15	.59"	A

1170

**IDENTIFICAÇÃO DOS ACESSÓRIOS/ IDENTIFICACIÓN DE ACCESORIOS/ IDENTIFICATION OF ACCESSORIES**

–NOTAS: A separação dos acessórios antes de iniciar a montagem facilitará a mesma. Os parafusos e cavilhas estão na escala real. Em caso de dúvida na identificação, coloque o acessório sobre a imagem.

–NOTAS:La separación de los accesorios antes de comenzar el armado facilitará el mismo. Los tornillos y taquetes son en escala real. En caso de dudas sobre la identificación, coloque el accesorio en la imagen.

–NOTES:The separation of the accessories before you start the assembly will facilitate the same. The screws and dowels are in real scale. In case of doubts about the identification, place the accessory on the image

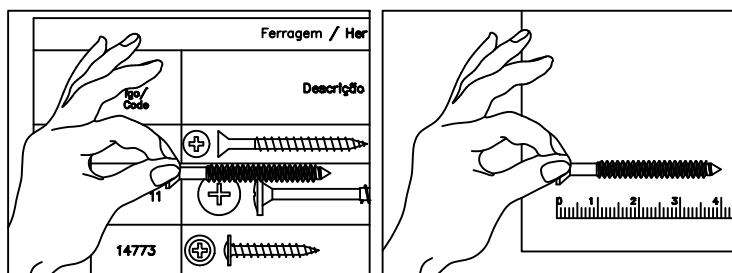
**Ferragem / Herrajes / Hardware**

	Código / Código / Code		Descrição / Descripción / Description	Quan./ Cant./ Amou.
PE9	2336		Parafuso estrutural/ Tornillo estructural/Structural screw 7x100	4
PE12	1260		Parafuso estrutural/ Tornillo estructural/Structural screw 7x70	4
PF7	4042		Parafuso/ Tornillo/ Screw 4x40 ZP	8
PP6	414		Parafuso/ Tornillo/ Screw 4,0X35	4
PC6	491		Parafuso/ Tornillo/ Screw 4x25	4
PC3	4214		Parafuso/ Tornillo/ Screw 3,5X14	60
PR2	108		Prego/Clavo/Nail 12x12	8
C1	1802		Cavilha/Tarugo/Dowel 6x30mm	2

**Prezado Montador:**

– Antes de iniciar a montagem verifique as condições do ambiente de montagem;  
 – Confira todas as peças das embalagens com a lista de peças contida neste manual;  
 – Separe os acessórios, confira as medidas dos parafusos com a escala;  
 – Siga todas as orientações deste manual de montagem para ter o direito à garantia do produto;  
 – Descarte as embalagens de forma correta, destinando o plástico e o papel para reciclagem;













**Estimado Montador:**

– Antes de iniciar a montagem verifique as condições do ambiente de montagem;  
 – Confira todas as peças das embalagens com una lista de peças contida neste manual;  
 – Separe os acessórios, confira as medidas dos parafusos com a escala;  
 – Siga todas las orientaciones deste manual de montaje para ter o direito à garantia do produto;  
 – Descarte como embalagens de forma correta, destinando o plástico e o papel para reciclagem;

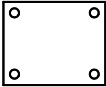
**Dear Fitter:**

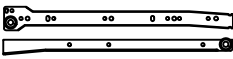
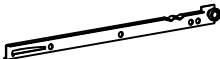
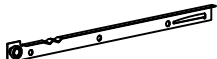
– Before starting montagem check as conditions of the assembly environment;  
 – Check out all the packaging com a list of fish contained in this manual;  
 – Separate the accessories, check the measures two parafuses com to scale;  
 – Follow all the guidelines of this manual montagem for ter or direct to guarantee of the product;  
 – Discard the packages correctly, allocating either plastic or paper for recycling;



Ferragem / Herrajes / Hardware			
	Código/ Código/ Code	Descrição / Descripción / Description	Quan./ Cant./ Amou.
CG	899	 Cantoneira I/Cantón I/Angle bracket	5
PX	5710	 Puxador/Manija del cajón/Andle	2
F	1620	 Fechadura com chave/Cerradura puerta/Door lock	1
LE	1622	 "L" de engate/Kit de cerradura/Lock kit	1
SA2	2384	 Sapata externa/Zapato externo/External shoe	1
CZ1	248	 Chave Allen/ Llave Allen/ Allen key 1/4"	1
CPL	Tl=4430 (Cinza)	 Tampa CPL/ Tapa CPL/ CPL cover 13mm	8
UT	1454	 União de metal/Unión de metal/ Metal union	3
EM	58	 Etiqueta marca/Tag label "Kappesberg"	1
CM1	169	 Corrediça de metal/Corredera de metal/Metal slide 350mm	2
CM1A		 Corrediça gaveta direita/Corredera derecha cajón/Drawer slide right	
CM1B		 Corrediça gaveta esquerda/Corredera del cajón izquierdo/Drawer left slide	
CM1C		 Corrediça lateral esquerda/Metallic slide the left filed/Corredera lateral izquierda	
CM1D		 Corrediça lateral direita/Metallic slide the right filed/Corredera lateral derecha	
PZ	4374	 Pé da mesa/Pie de mesa/Table foot (Par)	1
PC	4543	 Pé cilíndrico/Pie cilíndrico/Cylindrical foot	1



# 1170

**IDENTIFICAÇÃO DAS PEÇAS/ IDENTIFICACIÓN DE LAS PIEZAS/ PARTS IDENTIFICATION**

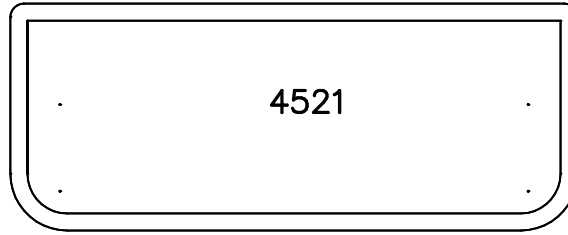
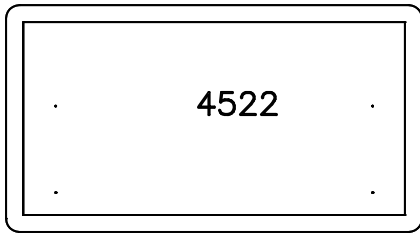

4524



2x

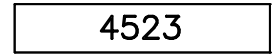

4523

2x



4519

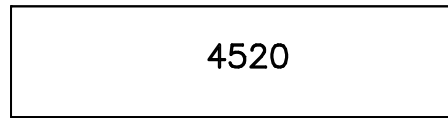

4520

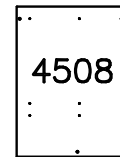

4508

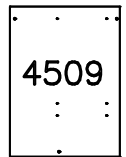

4509



4514

2x

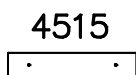

4515

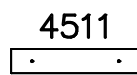

4511

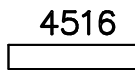

4516

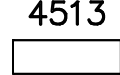

4513

2x

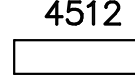

4512

4x

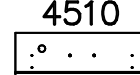

4510

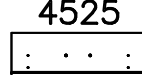

4525

NOTE: Este produto pode ser montado para a sua esquerda ou direita.

NOTES: Este producto puede ser montado para a sua esquerda ou direita.

NOTAS: This product can be mounted to your left or right.

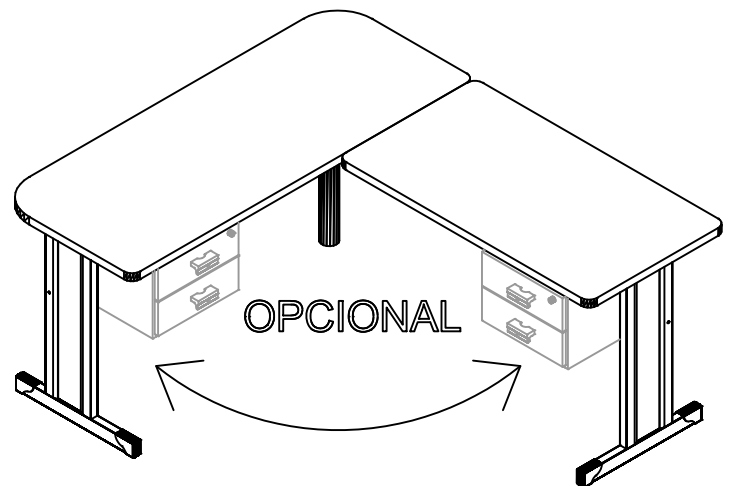
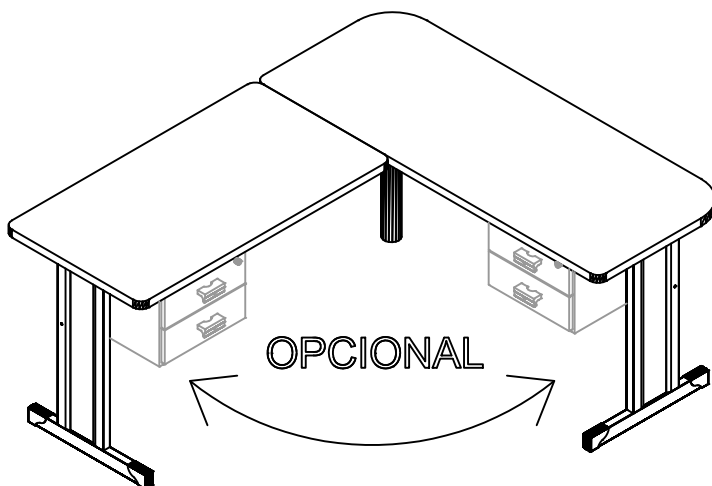

Duvidas? entrar em contato:  
¿Dudas? Ponerse en contacto:  
Doubts? Get in touch:

Fone: (51) 3635-8839  
www.kappesberg.com.br

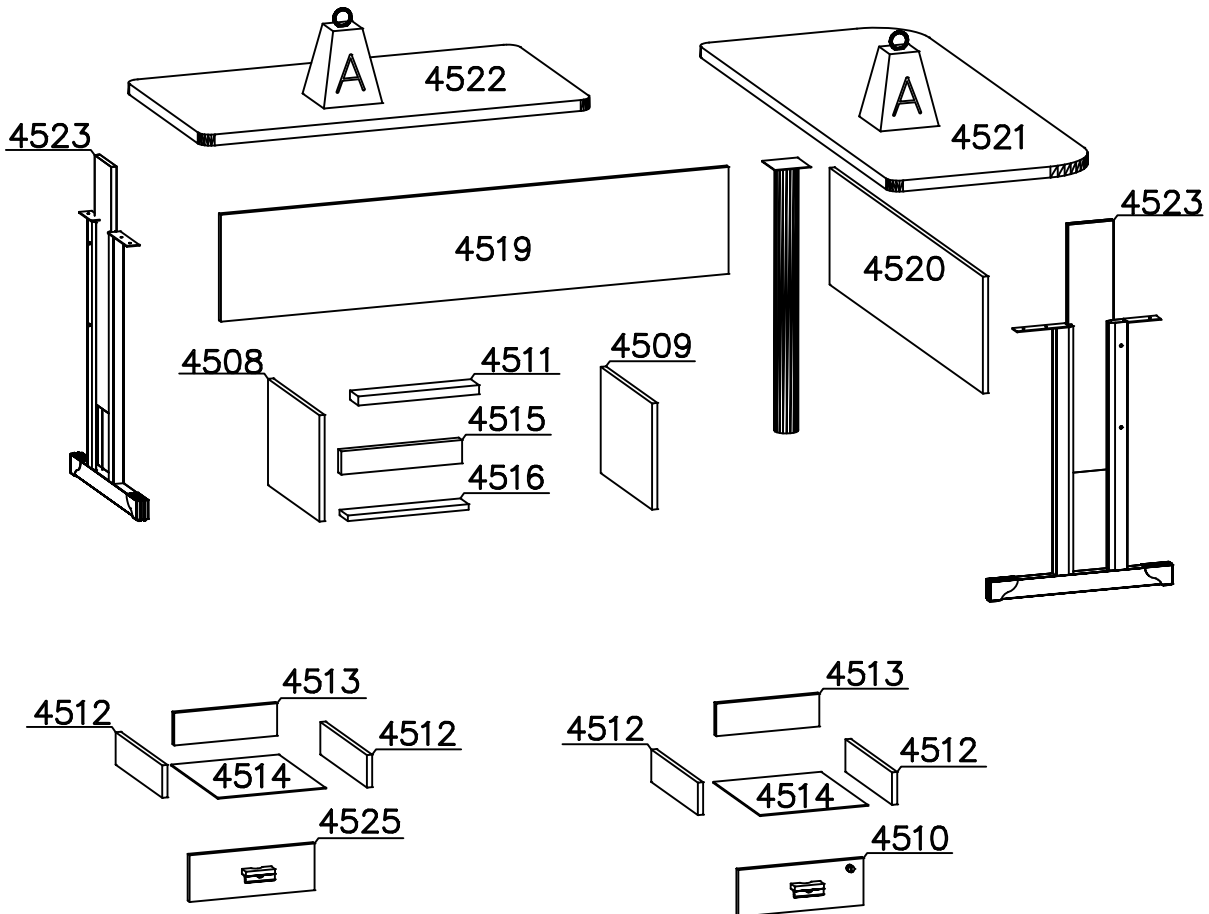
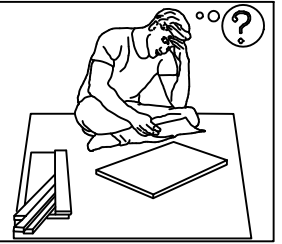

	Kg	lb
A	30	66.14lb

Em caso de dúvida, compare as ferragens com as imagens no decorrer do manual.

En caso de duda, compare el hardware con las imágenes del manual.

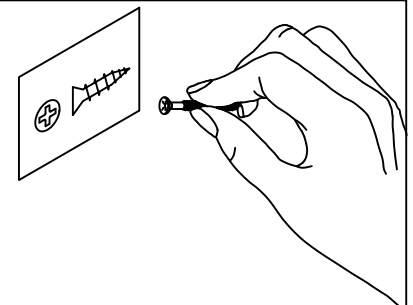

If in doubt, compare the hardware with the images throughout the manual



**MONTAGEM/ ASSEMBLE/ ARMADO**

1170

**1A PASSO/ PASO/ STEP**

CG		4
PC3		16

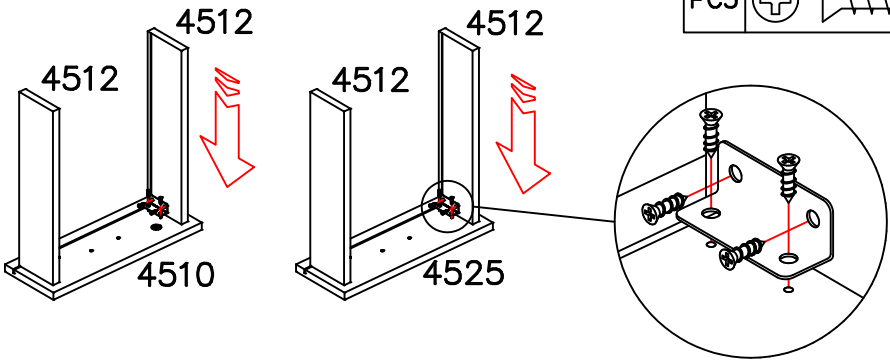
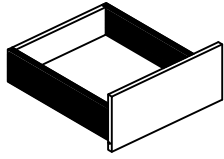

**1B PASSO/ PASO/ STEP**

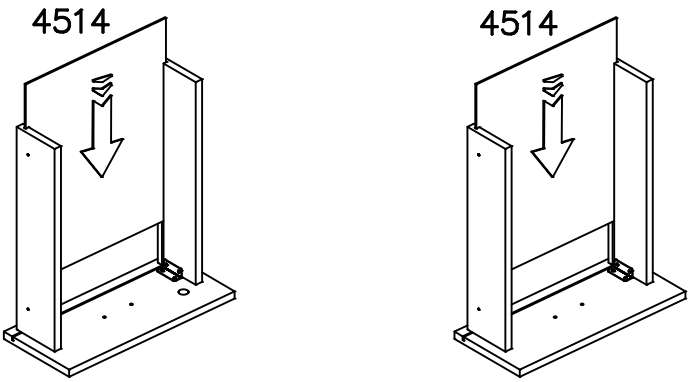
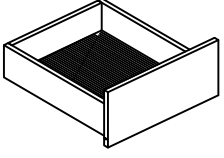

**1C PASSO/ PASO/ STEP**

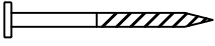

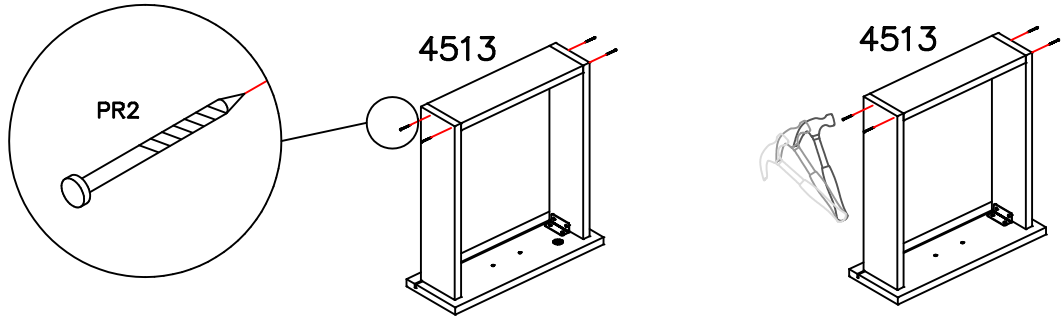
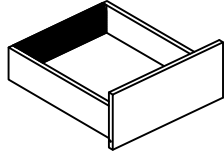
PR2		8
-----	---	---







# 1170

**02** PASSO/ PASO/ STEP

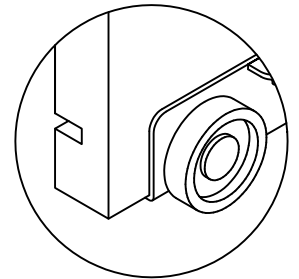
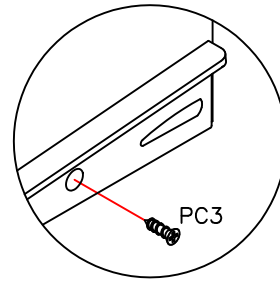
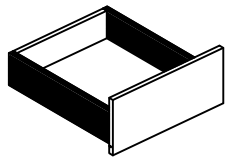
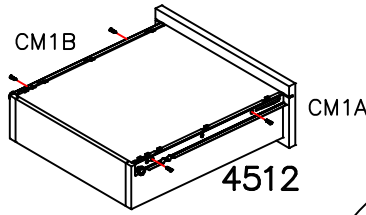
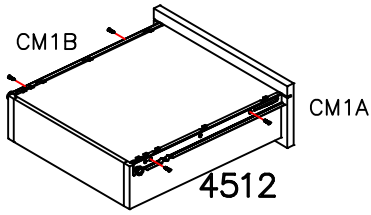
PC3		8
CM1A		2
CM1B		2



**03** PASSO/ PASO/ STEP

PC6		4
PX		2

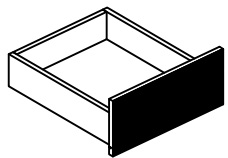
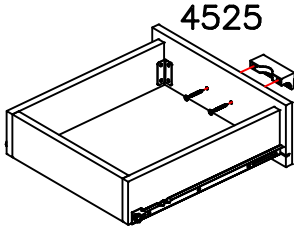
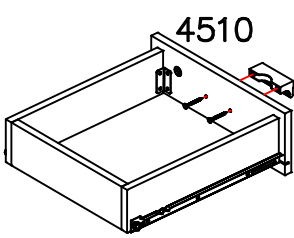

**04** PASSO/ PASO/ STEP

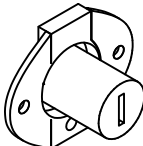
PC3		2
F		1

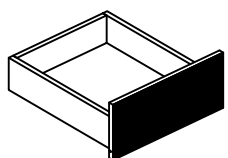
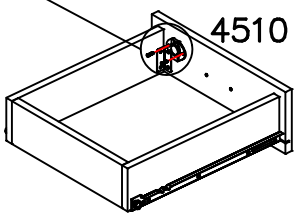
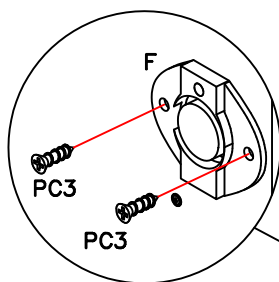

**05** PASSO/ PASO/ STEP

C1		2
----	---	---

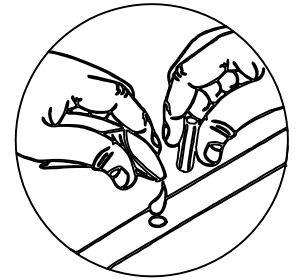
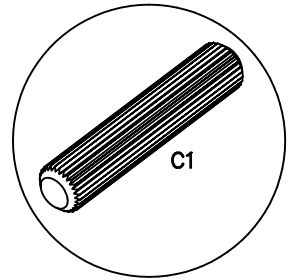
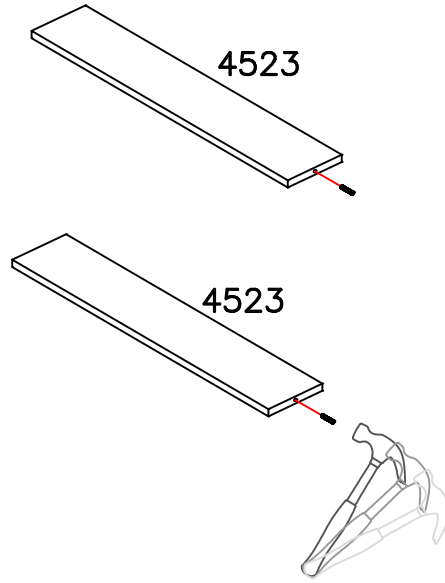
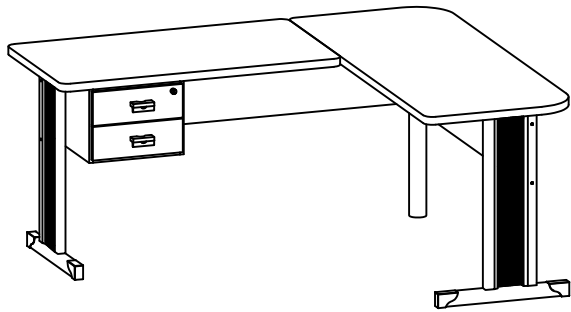

**06** PASSO/ PASO/ STEP

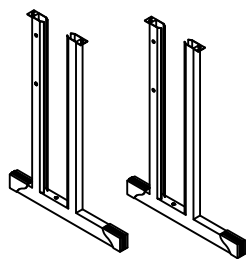
PZ		1
----	---	---

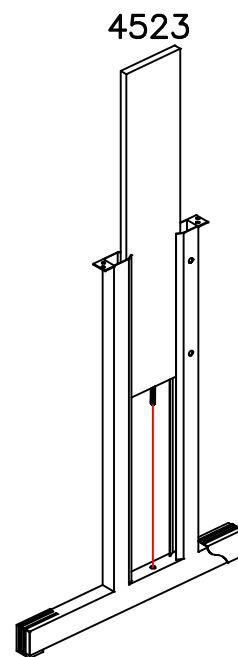
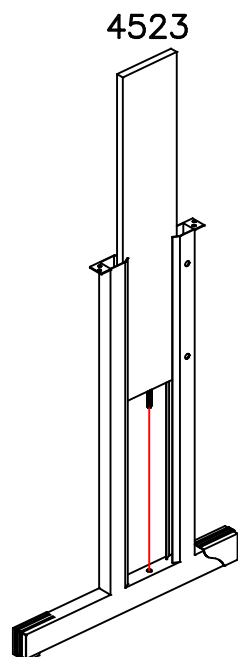
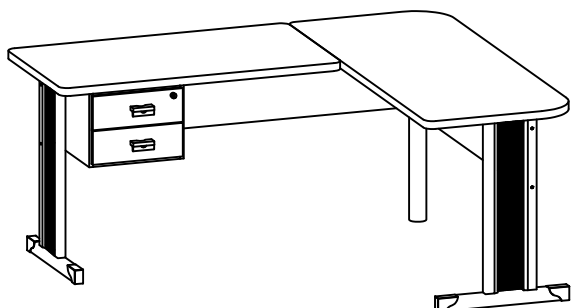

**07 PASSO/ PASO/ STEP**

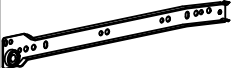
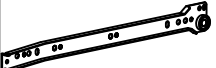
PC3		8
CM1C		2
CM1D		2

Vista detalhada da localização CORRETA do furo no trilho para o parafuso "PC3"

Vista detallada de la ubicación CORRECTA del orificio en el riel para el tornillo "PC3"

Detailed view of CORRECT hole location in the rail for the "PC3" Screw

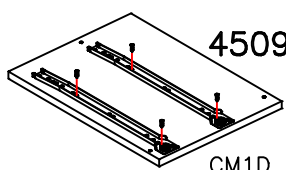
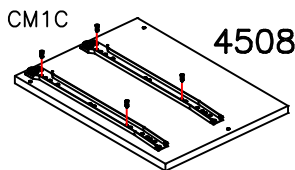
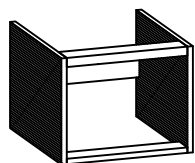
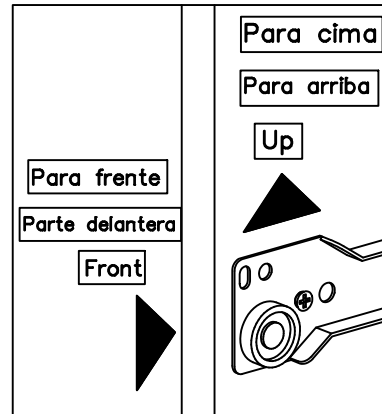
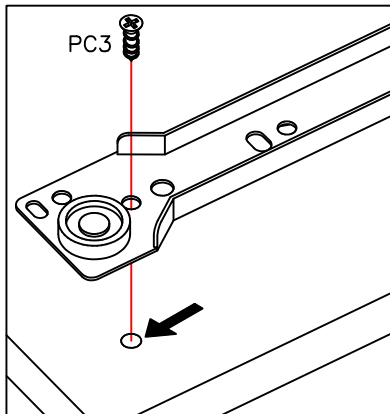
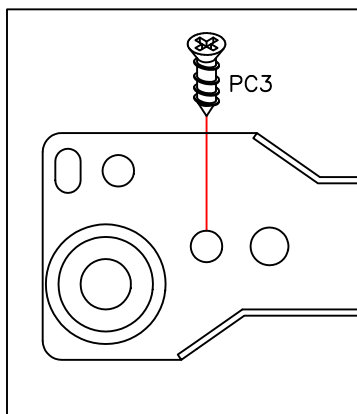



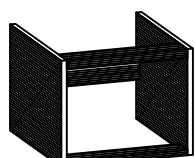
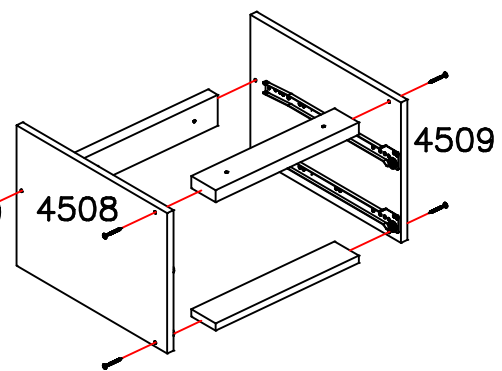
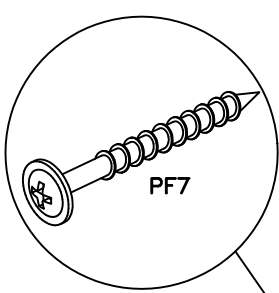

**08 PASSO/ PASO/ STEP**

PF7		6
-----	---	---

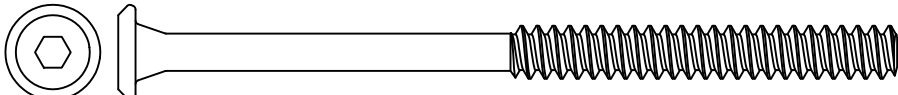
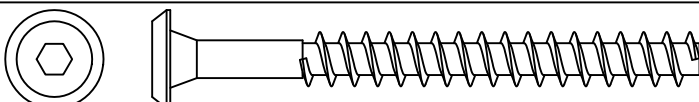
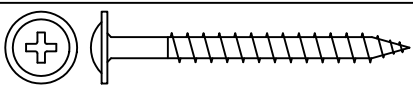

1170

09 PASSO/ PASO/ STEP

PE9		4
PE12		4
PF4		2
CZ1		1
CPL		8
PC		1

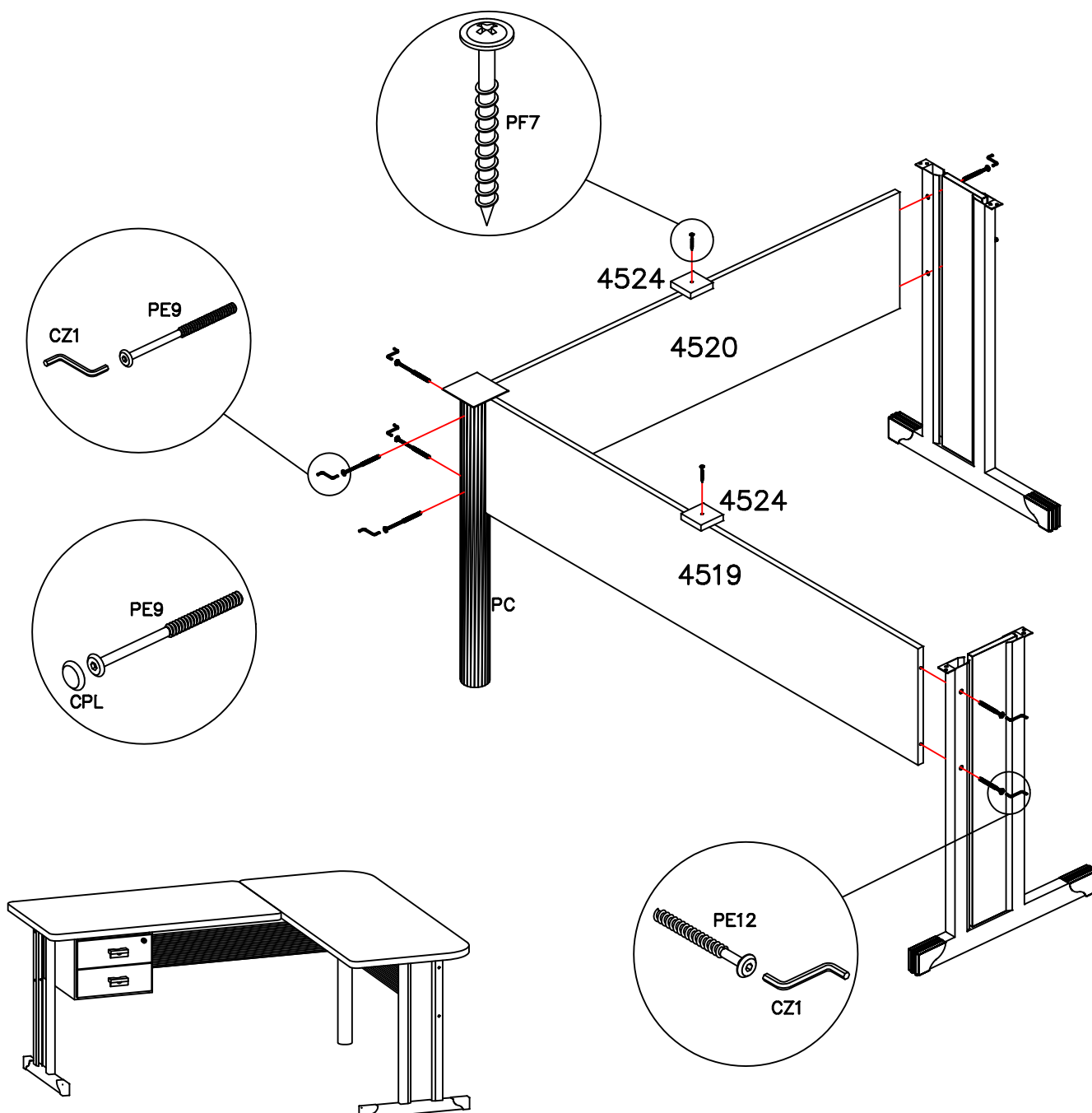

# 1170

**10** PASSO/ PASO/ STEP

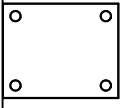
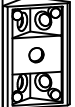
PC3		12
UT		2
CG		1

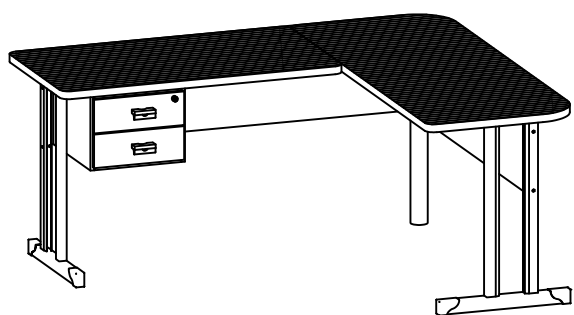
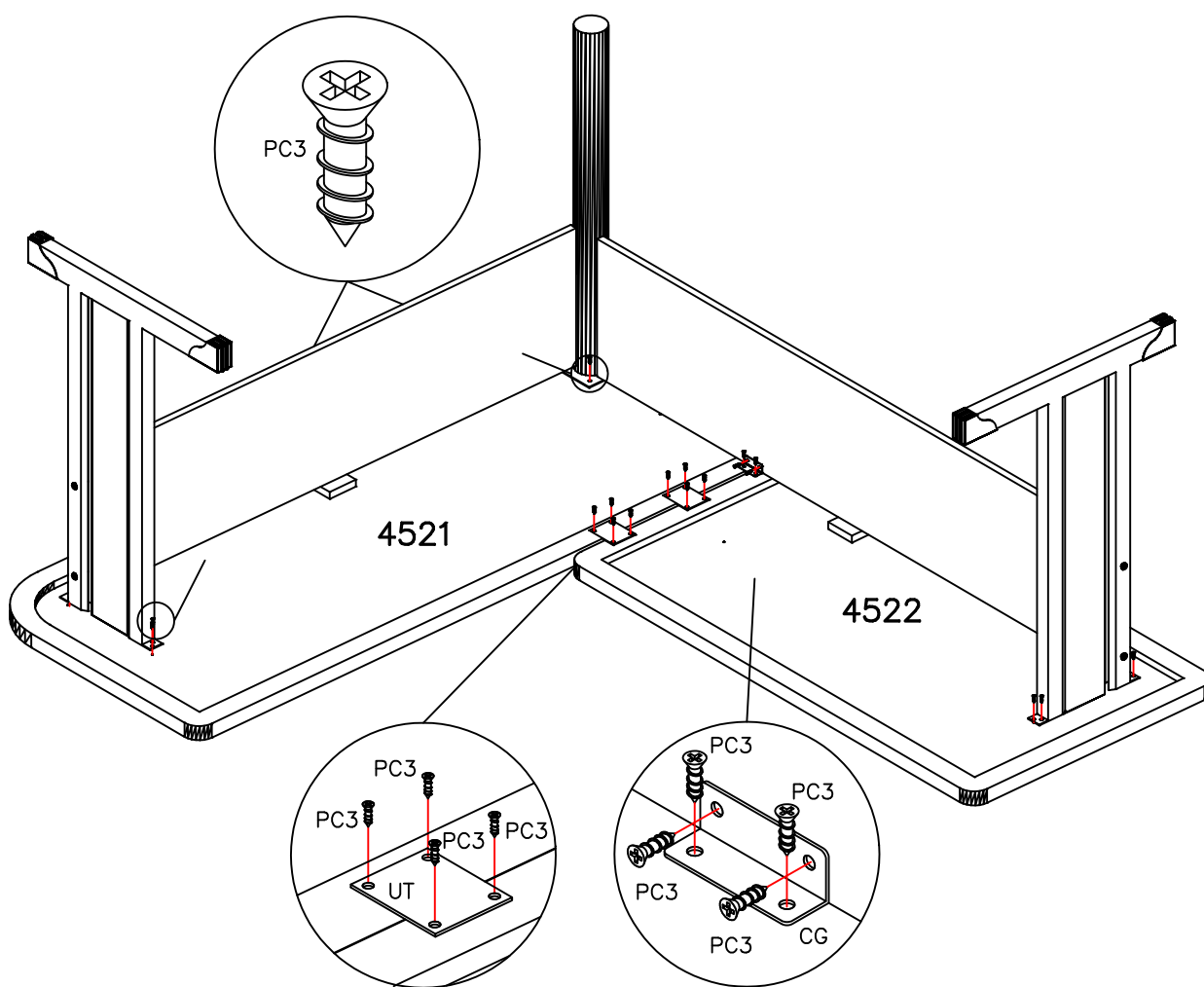

1170

11 PASSO/ PASO/ STEP

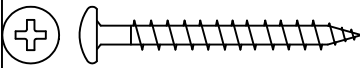
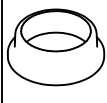
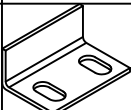
PC3		2
PP6		4
SA2		1
LE		1

