

Rua da Emancipação, 2000 - Tupandi - RS

Fone: (51) 3635-8800

www.kappesberg.com.br

E607

"GARANTIA POR DEFEITO DE FABRICAÇÃO DE 3 MESES."

Os "L" de metal e os parafusos para fixar o tampo estão dentro do acessório do Balcão.

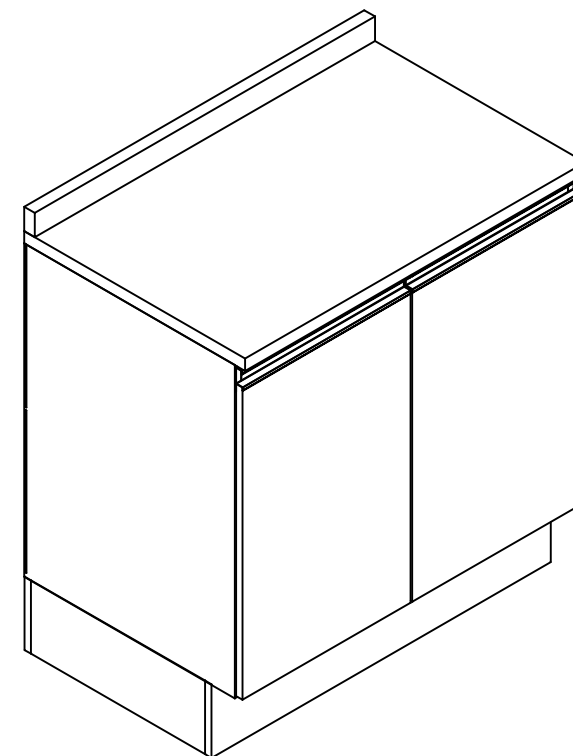
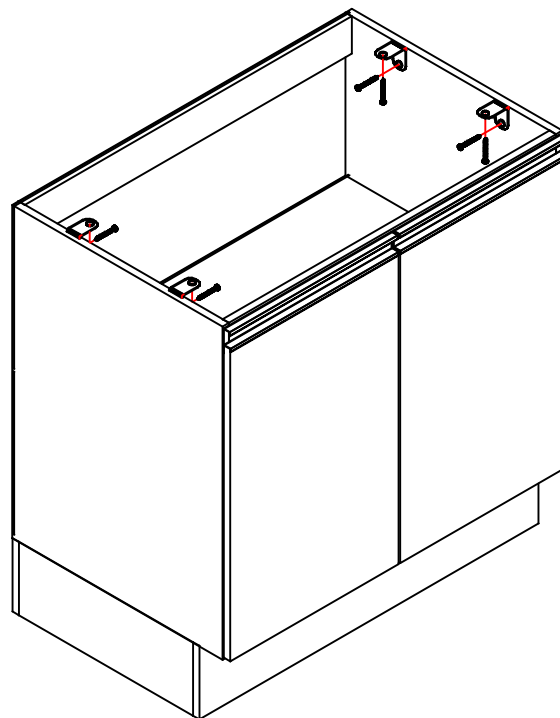
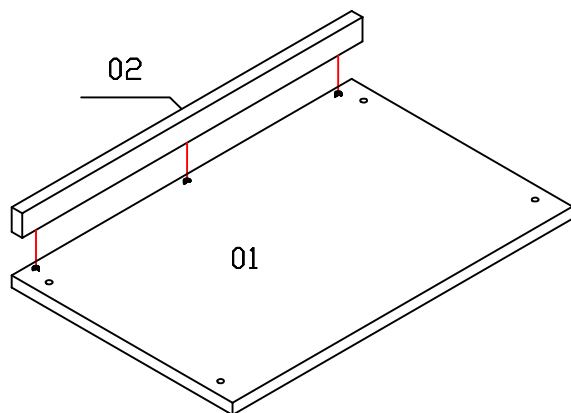

RELAÇÃO DE PEÇAS

01-TAMPO

02-SARRAFO DO TAMPO



"OBS: Para solicitar assistência técnica, utilize o código das peças indicada."

MANUAL DE MONTAGEM

INSTRUCCIONES DE MONTAJE

ASSEMBLY INSTRUCTIONS

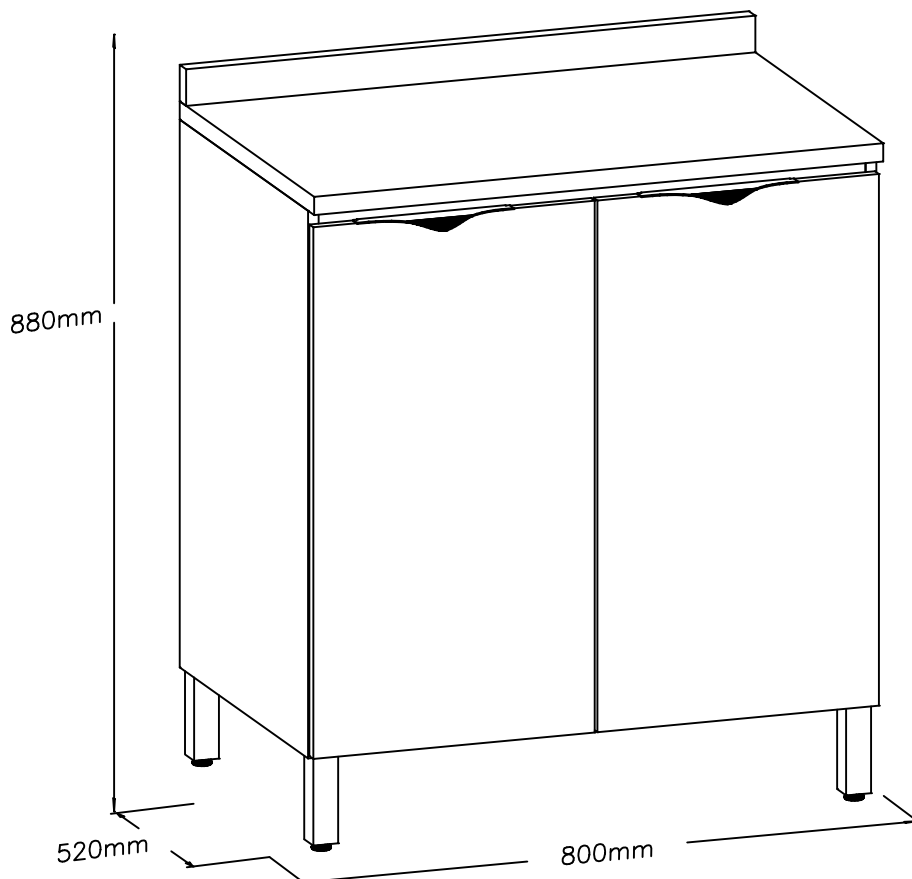

ATENÇÃO / PRECAUCIÓN / ATTENTION:

- 1 – Ler atentamente todo o manual antes de iniciar a montagem do móvel.
- 2 – A montagem deve ser feita em uma superfície plana e limpa.
- 3 – Recomenda-se utilizar a embalagem do móvel para forrar o chão e assim não danificá-lo.
 - 1 – Lea cuidadosamente todo el manual antes de comenzar el montaje.
 - 2 – La instalación debe hacerse sobre una superficie plana y limpia.
 - 3 – Recomanda ser utilizado para empaquetar móbil a la línea y tierra y por lo tanto dañar ellos.
- 1 – Read the entire manual carefully before starting the furniture assembly.
- 2 – The assembly must be done on a flat and clean surface.
- 3 – It is recommended to use the packaging of the furniture to cover the floor and thus not to damage them.

LIMPEZA E CONSERVAÇÃO / LIMPIEZA Y CONSERVACIÓN / CLEANLINESS AND CONSERVATION:

A limpeza do móvel deve ser feita com utilização de pano umedecido com água, podendo conter uma pequena quantidade de álcool. Não utilize produtos abrasivos.

La unidad de limpieza se debe realizar con el uso de paño humedecido con agua y puede contener una pequeña cantidad de alcohol. No utilice productos abrasivos.

The furniture should be cleaned with a cloth dampened with water and may contain a small amount of alcohol. Do not use abrasive products.

GARANTIA / GARANTÍA / WARRANTY:

90 dias para defeitos de fabricação.

90 días a defectos de fabricación.

90 days for manufacturing defects.

FERRAMENTAS NECESSÁRIAS / HERRAMIENTAS NECESARIAS / TOOLS REQUIRED:

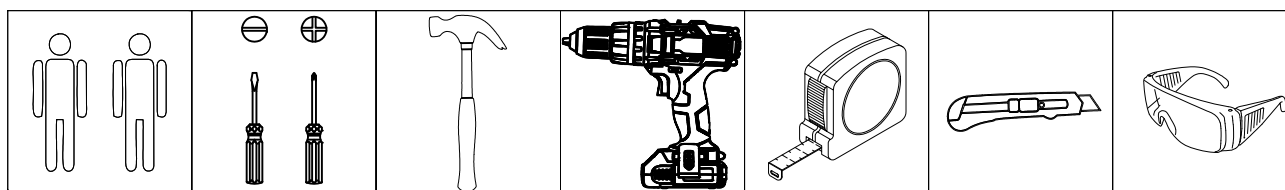

Acesse as dicas de
montagem no Youtube

Accede a los consejos de
montaje en Youtube.

Access the mounting tips on
Youtube.









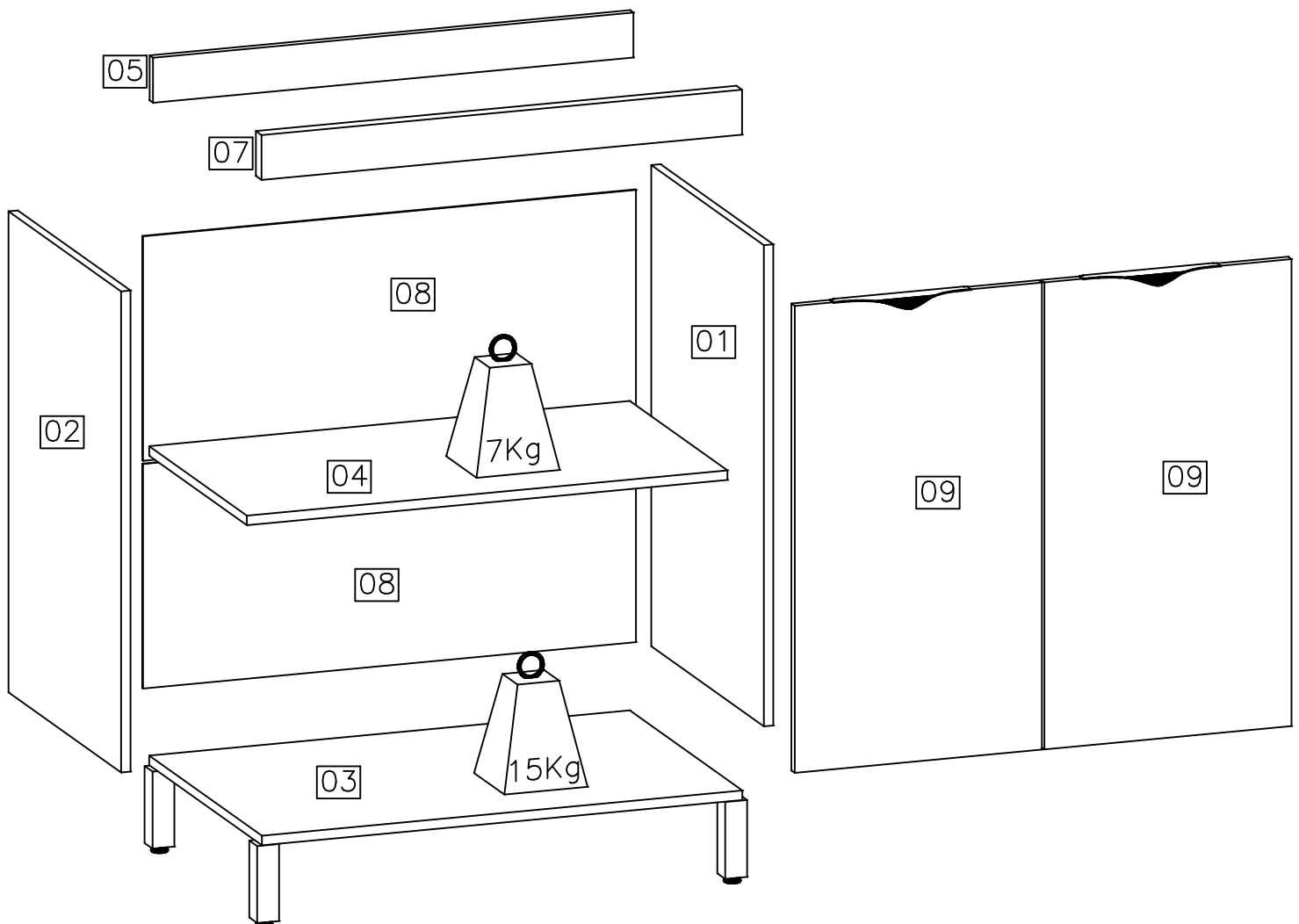





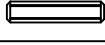

www.youtube.com/MoveisKappesberg

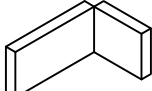
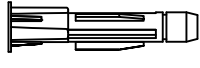

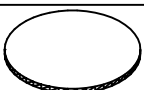
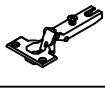

Lista de peças / Lista de piezas / List of pieces

Código/ Código/ Code	Descrição	Descripción	Description	Quantidade/ Cantidad/ Amount	Comprimento/ Longitud/ Length (mm)	Largura/ Ancho/ Width (mm)	Espessura/ Espesor/ Thickness (mm)	Caixa/ Caja/ Box
01	Lateral direita	Lateral derecha	Right side	1	750	496	15	A
02	Lateral esquerda	Lateral izquierda	Left side	1	750	496	15	A
03	Base	Pieza de suelo	Base	1	770	496	15	A
04	Prateleira	Estanterías	Shelf	1	770	430	15	A
05	Travessa traseira	Travesaño trasero	Cross-back piece	1	770	70	15	A
06	Sarrafo de apoio	Marco de apoyo	Support slat	1	790	50	15	A
07	Travessa frontal	Travesaño delantero	Front cross-piece	1	770	70	15	A
08	Costas	Pieza del fondo	Back panel	2	790	350	3	A
09	Portas	Puertas	Doors	2	728	396	15	A

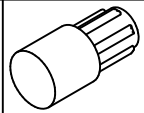

Ferragem / Herrajes / Hardware			
	Código/ Código/ Code	Descrição / Descripción / Description	Quan./ Cant./ Amou.
A	226	 Parafuso/ Tornillo/ Screw 4x40	11
B	4214	 Parafuso/ Tornillo/ Screw 3,5x14	12
C	50311	 Parafuso/ Tornillo/ Screw 5,0x65	4
D	491	 Parafuso/ Tornillo/ Screw 4x25	4
E	56243	 Parafuso/ Tornillo/ Screw 3,5x12 ZB	4
F	107	 Prego/Clavo/Nail 10x10	23
H	1802	 Cavilha/Tarugo/Peg 6x30mm	8
I	17024	 Suporte aéreo zb/Soporte de seguridad/Safety bracket	2
J	6959	 Capa para suporte branca/Cubierta de soporte/Support cover	2
K	529	 Bucha invasiva/Adapter sleeve/ Manga del adaptador	4
L	58	 Etiqueta marca/Tag label "Kappesberg"	1
M	51433	 Pézinho apolo/Perrito/Foot counter Champagne	4
O	53010	 Puxador de chapa nox/Asar/Handle Champagne	2
P	FROW=51255 (Freijo)	 Tapa furo/Tapa del agujero/Tap hole 13mm	12
Q	62432	 Dobradiça reta/Bisagra/Hinge 35mm	4
R	62434	 Calço para dobradiça/Calso/Shim	4
S	62436	 Parafuso da dobradiça/ Tornillo del bisagra/Hinge screw 4,0x12	16
T	FROW =26076 (Carvalle)	 Perfil H/Perfil de acabado/Finishing profile 770mm	1

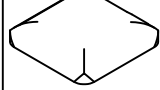
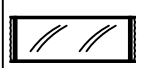
U	118		Suporte para prateleira/Soporte de estante/Shelf support	6
V	85		"L" de metal/Cantón "L" de metal/Metal angle bracket "L"	4
W	40534		Silicone/Silicona/ Selecone 10x10	4
Y	41		Cola branca em bisnaga/Cola blanca/White glue (10g)	1
01 Saco médio para acessórios				
01 Saco médio para puxadores				



-USO OBRIGATÓRIO DA CANTONEIRA DE METAL "X" NAS TRAVESSAS
 -USO MANDATORIO DEL CANTÓN DE METAL "X" EN LOS SLEEPERS
 -MANDATORY USE OF THE ANGLE METAL "X" IN THE SLEEPERS

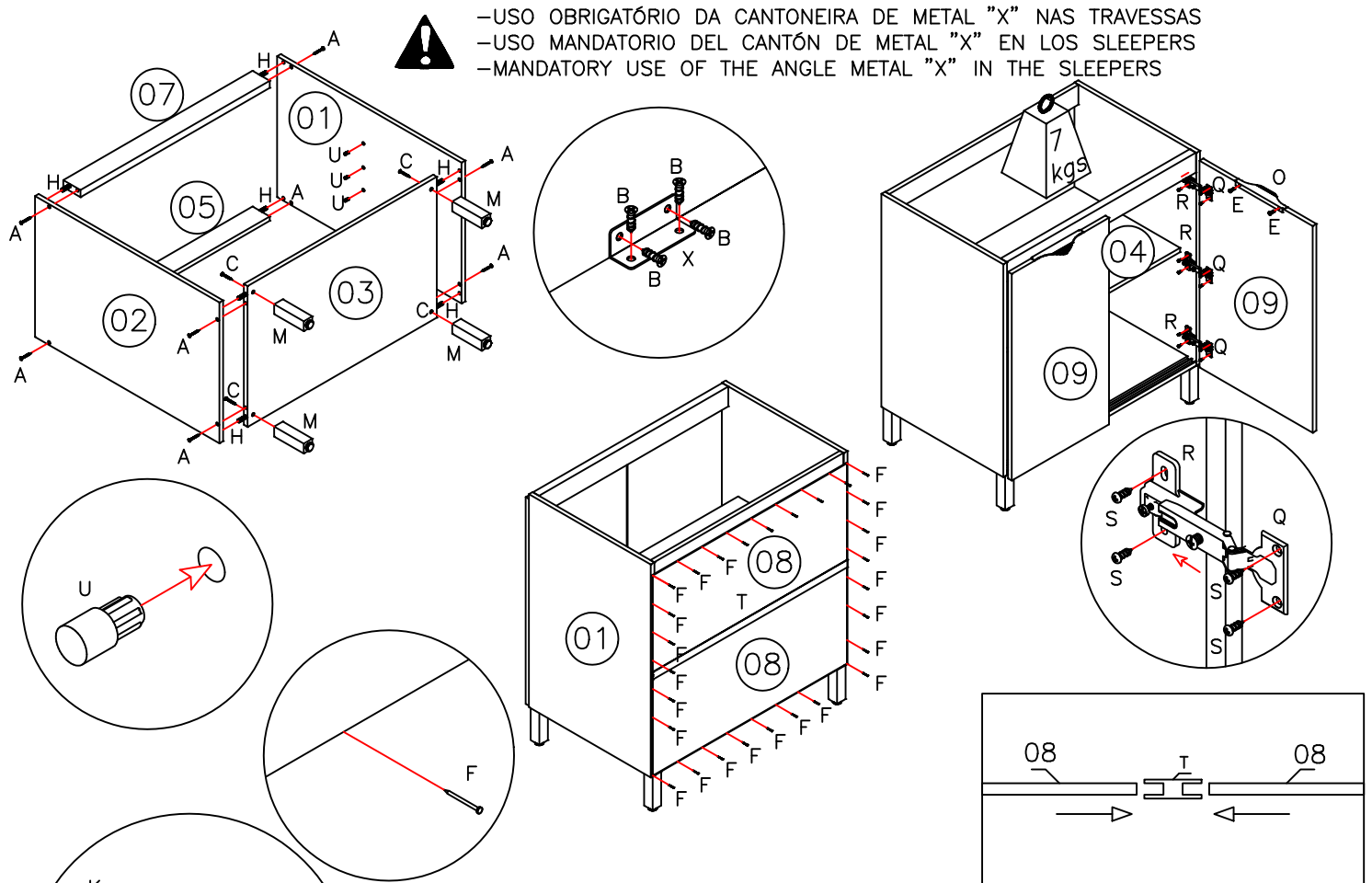

Para montar a cozinha suspensa:

- Utilize o sarrafo de apoio (06) que acompanha o móvel como apoio para sua fixação na parede, utilizando a bucha "K" e o parafuso "C".
- Em uma lateral fixe um suporte aéreo metálico "I" com o parafuso "B" e na parede com o parafuso "C" e com a bucha "K".
- Coloque uma capa "J" em cada suporte "I".

Para montar la cocina suspendida:

- Use el marco de apoyo (06) que viene con los muebles como soporte para su montaje en la pared utilizando el casquillo "K" y el tornillo "C".
- Por un lado, fije un soporte neumático metálico "I" con el tornillo "B" y la pared con el tornillo "C" y el casquillo "K".
- Coloque una cubierta "J" en cada soporte "I".

To mount the kitchen suspended:

- Use the support slat (06) board that comes with the furniture as a support for its wall mounting using the "K" bush and the "C" screw.
- On one side, fix a metallic air support "I" with the screw "B" and the wall with the screw "C" and the bushing "K".
- Place a "J" cover on each "I" bracket.

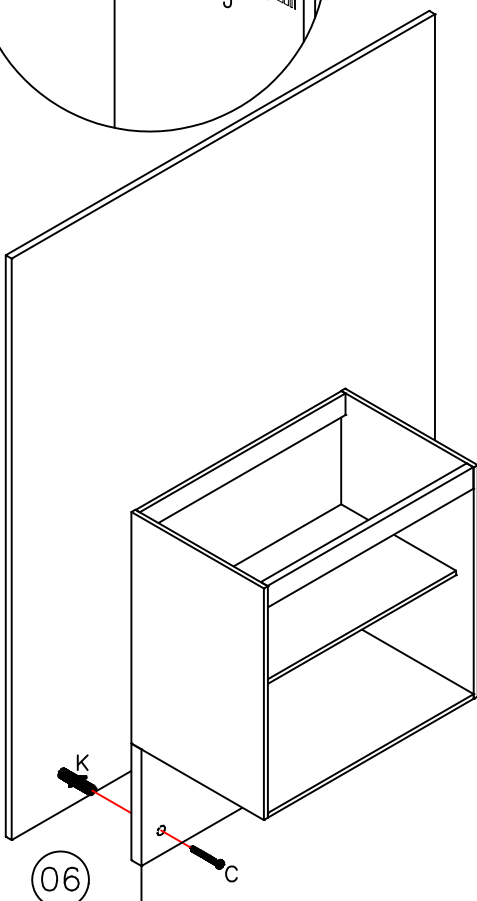

MANUAL DE MONTAGEM

INSTRUCCIONES DE MONTAJE

ASSEMBLY INSTRUCTIONS

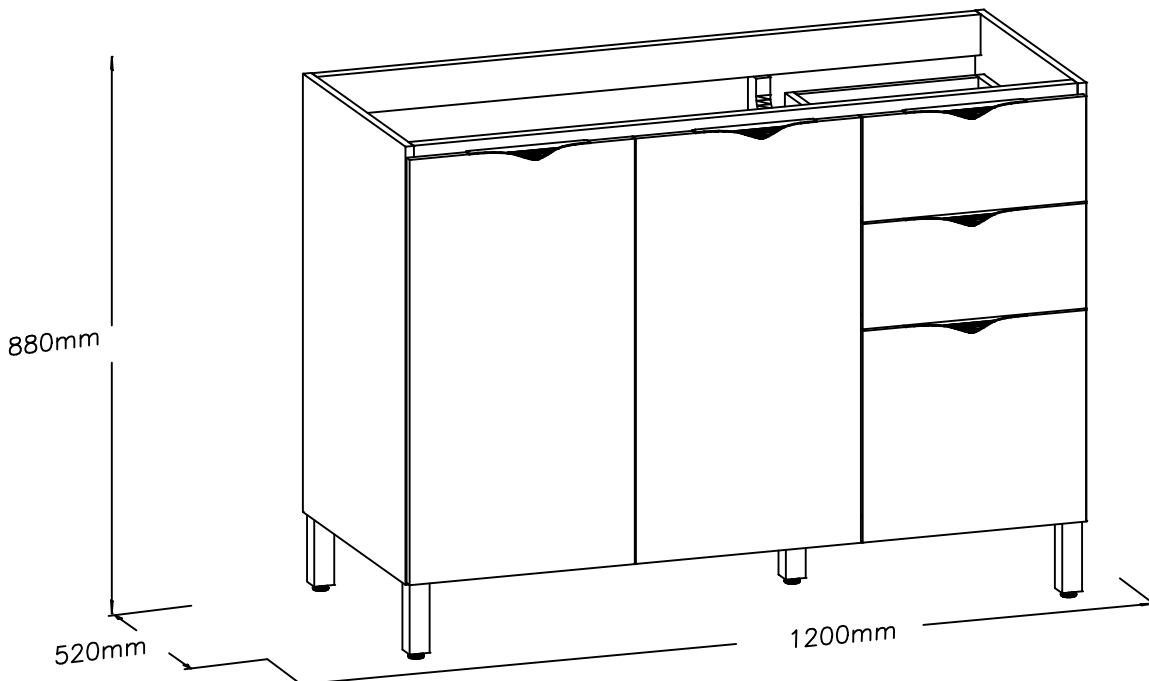
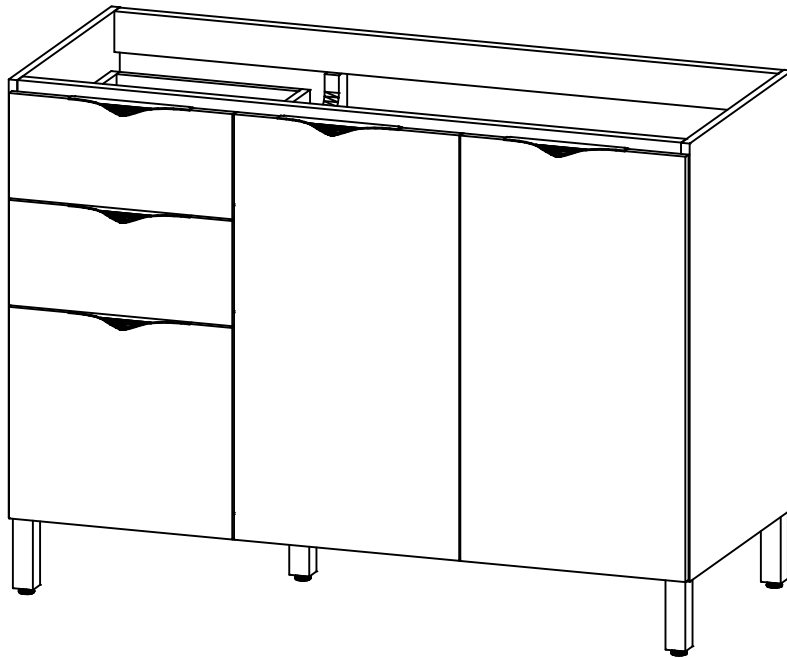

ATENÇÃO / PRECAUCIÓN / ATTENTION:

- 1 – Ler atentamente todo o manual antes de iniciar a montagem do móvel.
- 2 – A montagem deve ser feita em uma superfície plana e limpa.
- 3 – Recomenda-se utilizar a embalagem do móvel para forrar e chão e assim não danificá-lo.
 - 1 – Lea cuidadosamente todo el manual antes de comenzar el montaje.
 - 2 – La instalación debe hacerse sobre una superficie plana y limpia.
 - 3 – Recomanda ser utilizado para empaquetar móbil a la línea y tierra y por lo tanto dañar ellos.
- 1 – Read the entire manual carefully before starting the furniture assembly.
- 2 – The assembly must be done on a flat and clean surface.
- 3 – It is recommended to use the packaging of the furniture to cover and floor and thus not to damage them.

LIMPEZA E CONSERVAÇÃO / LIMPIEZA Y CONSERVACIÓN / CLEANLINESS AND CONSERVATION:

A limpeza do móvel deve ser feita com utilização de pano umedecido com água, podendo conter uma pequena quantidade de álcool. Não utilize produtos abrasivos.

La unidad de limpieza se debe realizar con el uso de paño humedecido con agua y puede contener una pequeña cantidad de alcohol. No utilice productos abrasivos.

The furniture should be cleaned with a cloth dampened with water and may contain a small amount of alcohol. Do not use abrasive products.

GARANTIA / GARANTÍA / WARRANTY:

90 dias para defeitos de fabricação.

90 días a defectos de fabricación.

90 days for manufacturing defects.

FERRAMENTAS NECESSÁRIAS / HERRAMIENTAS NECESARIAS / TOOLS REQUIRED:

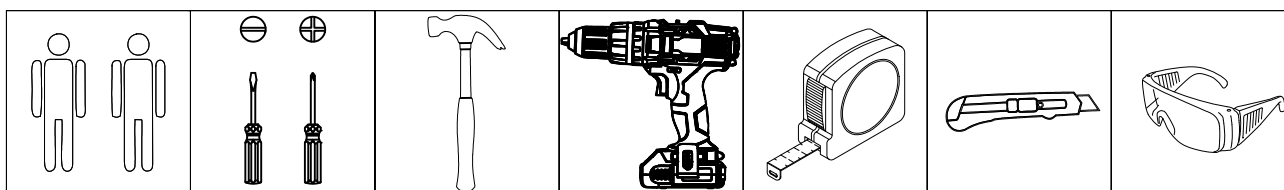

Acesse as dicas de
montagem no Youtube

Accede a los consejos de
montaje en Youtube.

Access the mounting tips on
Youtube.









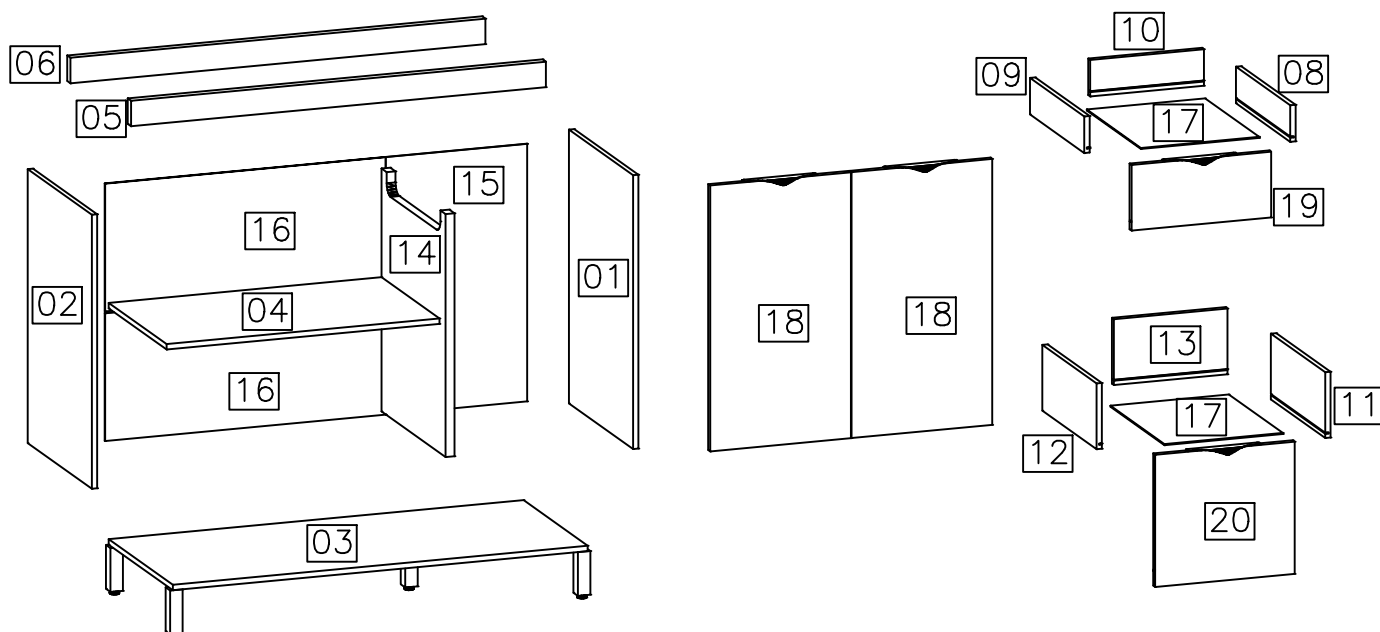

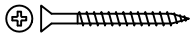

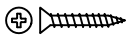

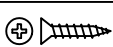

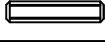

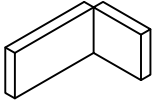
www.youtube.com/MoveisKappesberg



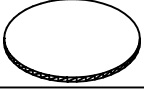

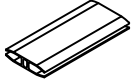

Lista de peças / Lista de piezas / List of pieces

Código/ Código/ Code	Descrição	Descripción	Description	Quantidade/ Cantidad/ Amount	Comprimento/ Longitud/ Length (mm)	Largura/ Ancho/ Width (mm)	Espessura/ Espesor/ Thickness (mm)	Caixa/ Caja/ Box
01	Lateral direita	Lateral derecha	Right side	1	750	496	15	A
02	Lateral esquerda	Lateral izquierda	Left side	1	750	496	15	A
03	Base	Pieza de suelo	Base	1	1168	496	15	A
04	Prateleira	Estanterías	Shelf	1	768	448	15	A
05	Travessa frontal	Travesaño delantero	Front cross-piece	1	1168	70	15	A
06	Travessa traseira	Travesaño trasero	Cross-back piece	1	1168	70	15	A
07	Sarrafo de apoio	Marco de apoyo	Support slat	1	1188	50	15	A
08	Lateral de gaveta dir.	Lateral de cajón izquierda	Right drawer side	2	420	100	15	A
09	Lateral de gaveta esq.	Lateral de cajón derecha	Left drawer side	2	420	100	15	A
10	Cabeceira de gaveta	Cabecera de cajón	Back drawer	2	320	100	15	A
11	Lateral direita do gavetão	Lateral de cajón derecha	Right drawer side	1	420	180	15	A
12	Lateral esquerda do gavetão	Lateral de cajón izquierda	Left drawer side	1	420	180	15	A
13	Cabeceira de gavetão	Cabecera de cajón mayor	Largest drawer headboard	1	320	180	15	A
14	Divisória	División	Division	1	665	496	25	A
15	Costas das gavetas	Piezas de fondo de los cajones	Bottom parts of the drawers	1	705	400	3	A
16	Costas	Pieza del fondo	Back panel	2	790	350	3	A
17	Fundo de gaveta	Fondo de cajón	Bottom drawer	3	418	333	3	A
18	Portas	Puertas	Doors	2	728	396	15	A
19	Frente de gaveta	Frente de cajón	Front drawer	2	393	180	15	A
20	Frente do gavetão	Frente de cajón mayor	Largest drawer front	1	393	362	15	A

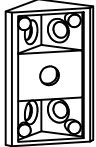
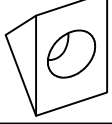

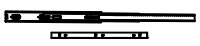
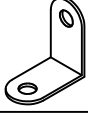
Ferragem / Herrajes / Hardware			
	Código/ Código/ Code	Descrição / Descripción / Description	Quan. / Cant. / Amou.
A	226	 Parafuso/ Tornillo/ Screw 4x40	20
B	4214	 Parafuso/ Tornillo/ Screw 3,5x14	82
C	50311	 Parafuso/ Tornillo/ Screw 5,0x65	6
D	491	 Parafuso/ Tornillo/ Screw 4x25	4
E	56243	 Parafuso/ Tornillo/ Screw 3,5x12 ZB	10
F	5256	 Parafuso/ Tornillo/ Screw 4x20	6
G	107	 Prego/Clavo/Nail 10x10	35
I	1802	 Cavilha/Tarugo/Peg 6x30mm	32
J	17024	 Suporte aéreo zb/Soporte de seguridad/Safety bracket	3
K	6959	 Capa para suporte branca/Cubierta de soporte/Support cover	3
L	529	 Bucha invasa/Adapter sleeve/ Manga del adaptador	6
M	58	 Etiqueta marca/Tag label "Kappesberg"	1
N	51433	 Pézinho apolo/Perrito/Foot counter Champagne	5
P	53010	 Puxador de chapa nox/Asar/Handle Champagne	5
Q	FROW= 51255 (Freijo)	 Tapa furo/Tapa del agujero/Tap hole 13mm	27
R	62432	 Dobradiça reta/Bisagra/Hinge 35mm	4
S	62434	 Calço para dobradiça/Calso/Shi m	4
T	62436	 Parafuso da dobradiça/ Tornillo del bisagra/Hinge screw 4,0x12	16
V	FROW =26076 (Carvalle)	 Perfil H/Perfil de acabado/Finishing profile 770mm	1
Z	40534	 Silicone/Silicona/ Selecone 10x10	8

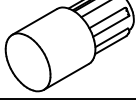
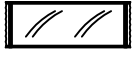
AA	899		Cantoneira /Cantонера /Ledge with	6
AB	18458		Suporte triangular preto/Soporte triangular negro/Black triangular support	6
AC	1423		Fixador de costa/Fijador de costa/Shore Fixer	7
AD	38305		Trilho telescópico mini light/Corredera de metal/Metal slide 400mm	3
AE	85		"L" de metal/Cantón "L" de metal/Metal angle bracket "L"	6
AF	8578		"L" de Zamaq/Cantón "L" /angle bracket "L"	2
AH	118		Suporte para prateleira/Soporte de estante/Shelf support	6
AJ	41		Cola branca em bisnaga/Cola blanca/White glue (10g)	1
01 Saco médio para acessórios				
01 Saco médio para puxadores				





-USO OBRIGATÓRIO DA CANTONEIRA DE METAL "AI" NAS TRAVESSAS
-USO MANDATORIO DEL CANTÓN DE METAL "AI" EN LOS SLEEPERS
-MANDATORY USE OF THE ANGLE METAL "AI" IN THE SLEEPERS

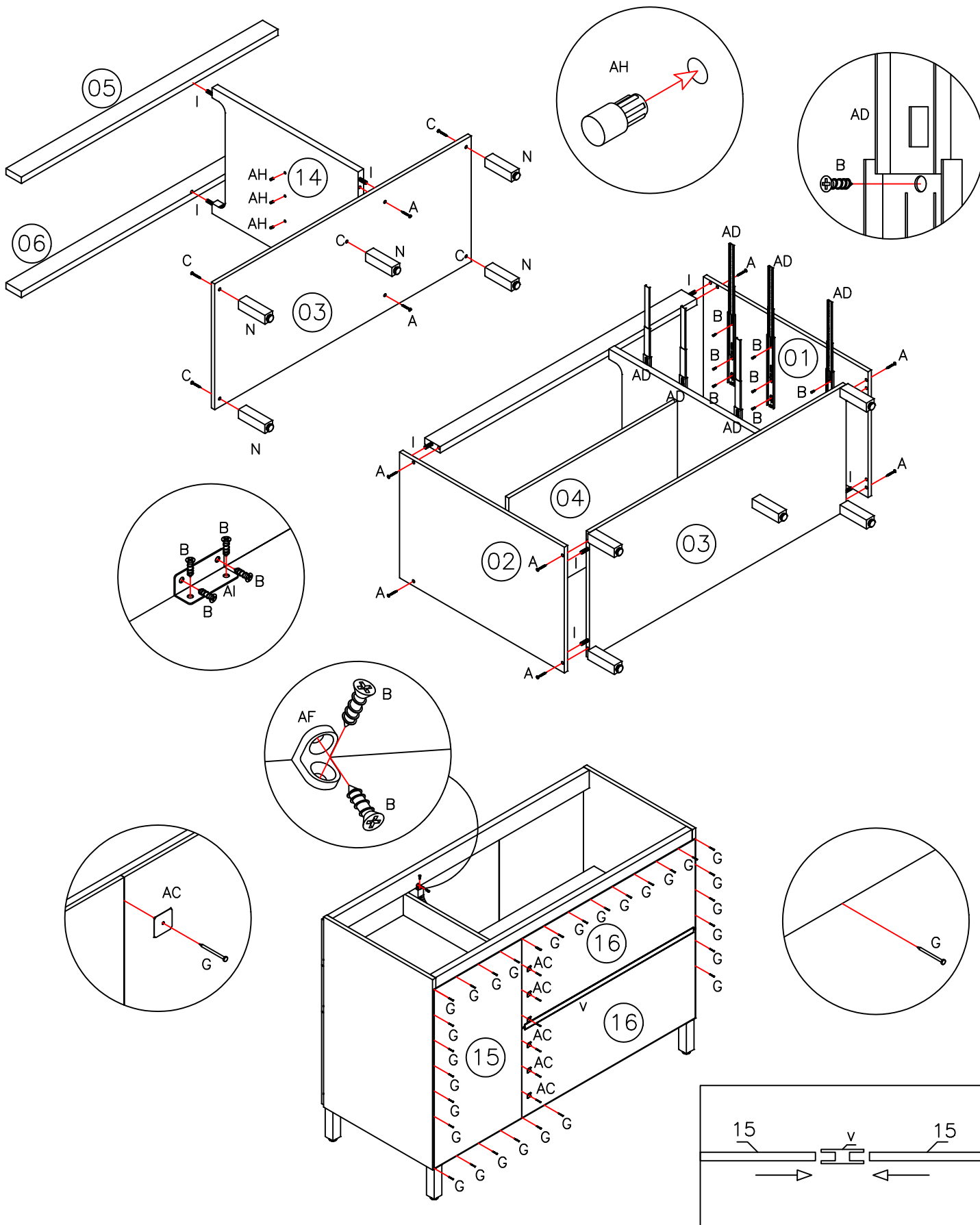

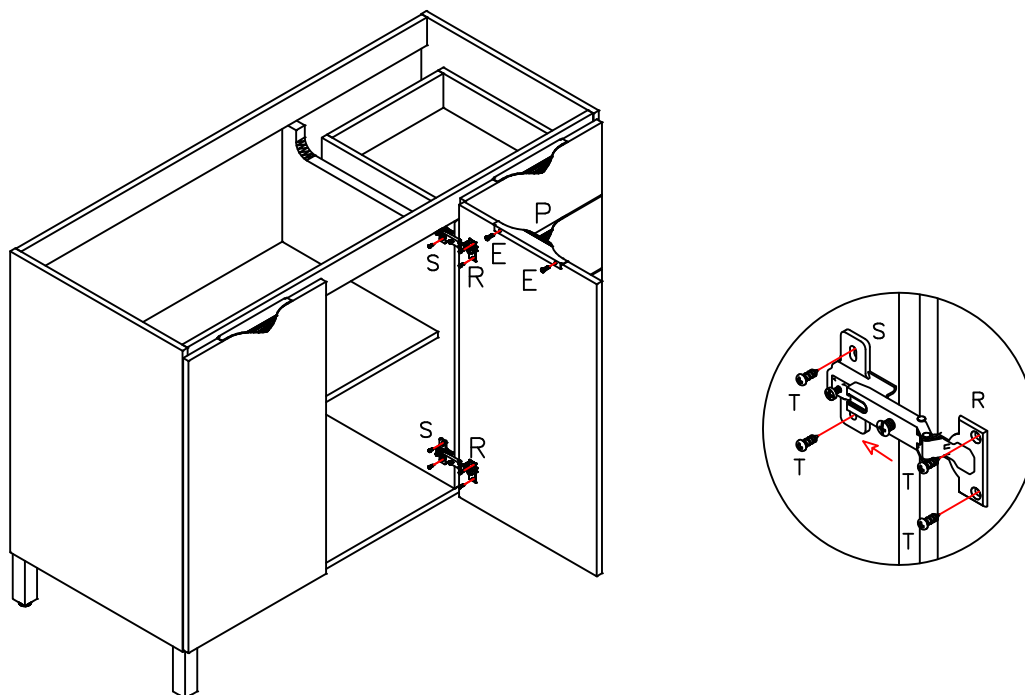

Para montar a cozinha suspensa:

- Utilize o sarrafo de apoio (07) que acompanha o móvel como apoio para sua fixação na parede, utilizando a bucha "L" e o parafuso "C".
- Em uma lateral fixe um suporte aéreo metalizado "J" com o parafuso "B" e na parede com o parafuso "C" e com a bucha "L".
- Coloque uma capa "K" em cada suporte "J".

Para montar la cocina suspendida:

- Use el marco de apoyo (07) que viene con los muebles como soporte para su montaje en la pared utilizando el casquillo "L" y el tornillo "C".
- Por un lado, fije un soporte neumático metálico "J" con el tornillo "B" y la pared con el tornillo "C" y el casquillo "L".
- Coloque una cubierta "K" en cada soporte "J".

To mount the kitchen suspended:

- Use the support slat (07) board that comes with the furniture as a support for its wall mounting using the "J" bush and the "C" screw.
- On one side, fix a metallic air support "I" with the screw "B" and the wall with the screw "C" and the bushing "L".
- Place a "K" cover on each "J" bracket.

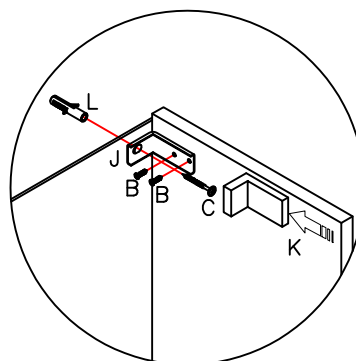
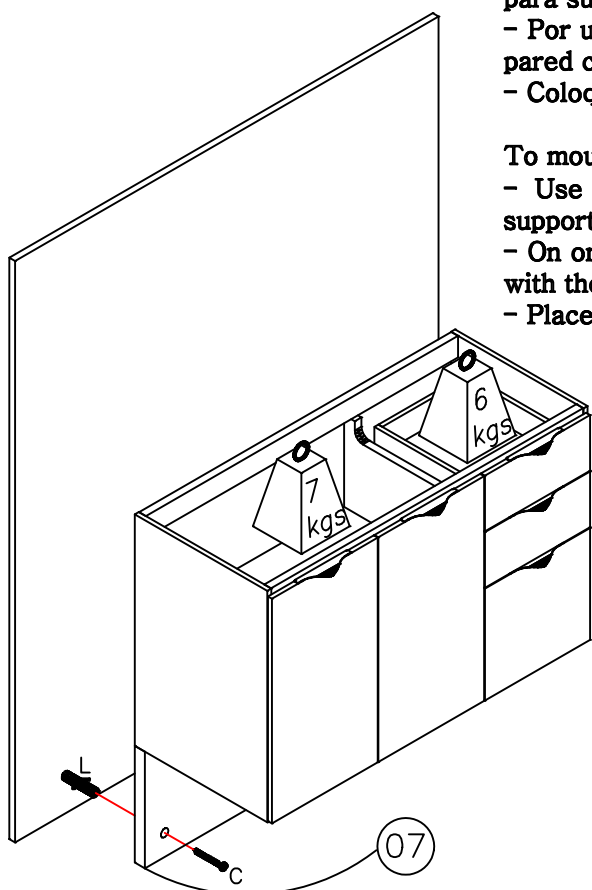

MANUAL DE MONTAGEM

INSTRUCCIONES DE MONTAJE

ASSEMBLY INSTRUCTIONS

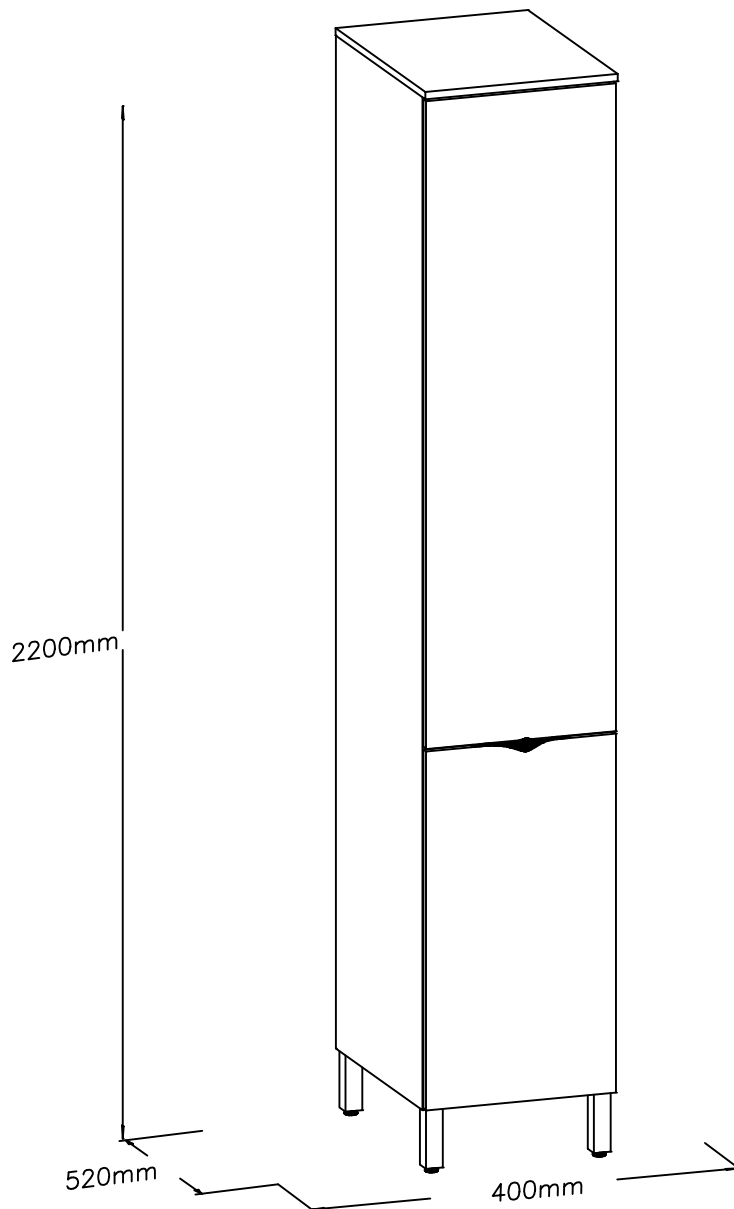

ATENÇÃO / PRECAUCIÓN / ATTENTION:

- 1 – Ler atentamente todo o manual antes de iniciar a montagem do móvel.
- 2 – A montagem deve ser feita em uma superfície plana e limpa.
- 3 – Recomenda-se utilizar a embalagem do móvel para forrar e chão e assim não danificá-lo.
 - 1 – Lea cuidadosamente todo el manual antes de comenzar el montaje.
 - 2 – La instalación debe hacerse sobre una superficie plana y limpia.
 - 3 – Recomanda ser utilizado para empaquetar móbil a la línea y tierra y por lo tanto dañar ellos.
- 1 – Read the entire manual carefully before starting the furniture assembly.
- 2 – The assembly must be done on a flat and clean surface.
- 3 – It is recommended to use the packaging of the furniture to cover and floor and thus not to damage them.

LIMPEZA E CONSERVAÇÃO / LIMPIEZA Y CONSERVACIÓN / CLEANLINESS AND CONSERVATION:

A limpeza do móvel deve ser feita com utilização de pano umedecido com água, podendo conter uma pequena quantidade de álcool. Não utilize produtos abrasivos.

La unidad de limpieza se debe realizar con el uso de paño humedecido con agua y puede contener una pequeña cantidad de alcohol. No utilice productos abrasivos.

The furniture should be cleaned with a cloth dampened with water and may contain a small amount of alcohol. Do not use abrasive products.

GARANTIA / GARANTÍA / WARRANTY:

90 dias para defeitos de fabricação.

90 días a defectos de fabricación.

90 days for manufacturing defects.

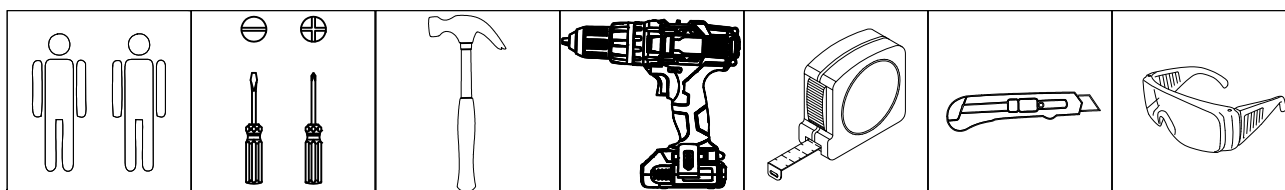
FERRAMENTAS NECESSÁRIAS / HERRAMIENTAS NECESARIAS / TOOLS REQUIRED:

Acesse as dicas de
montagem no Youtube

Accede a los consejos de
montaje en Youtube.

Access the mounting tips on
Youtube.









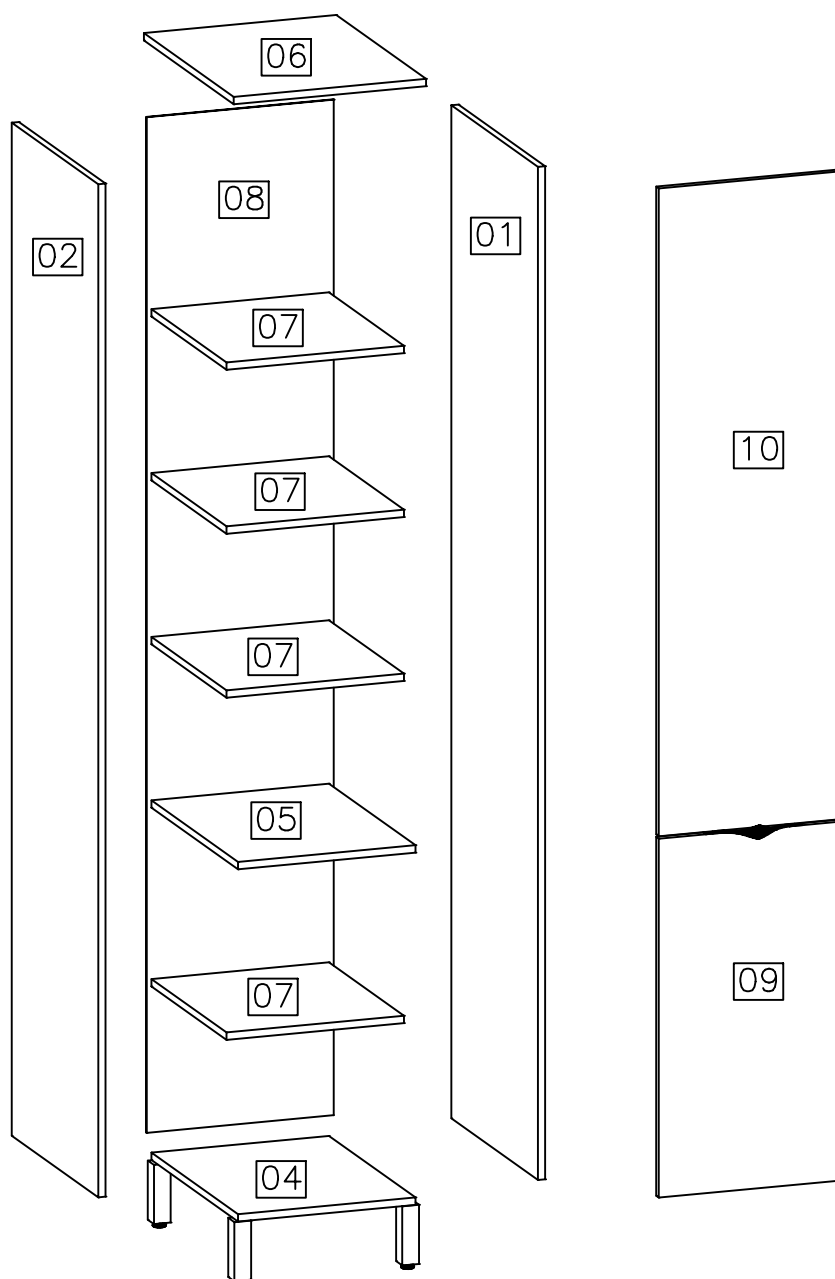

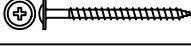

www.youtube.com/MoveisKappesberg



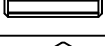

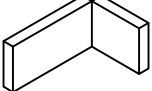

Lista de peças / Lista de piezas / List of pieces

Código/ Código/ Code	Descrição	Descripción	Description	Quantidade/ Cantidad/ Amount	Comprimento/ Longitud/ Length (mm)	Largura/ Ancho/ Width (mm)	Espessura/ Espesor/ Thickness (mm)	Caixa/ Caja/ Box
01	Lateral direita	Lateral derecha	Right side	1	2055	496	15	A
02	Lateral esquerda	Lateral izquierda	Left side	1	2055	496	15	A
03	Sarrafo de apoio	Marco de apoyo	Support slat	1	390	50	15	A
04	Base	Pieza de suelo	Base	1	370	496	15	A
05	Tampo	Tapa del cajón	Top of drawers	1	370	496	15	A
06	Chapéu	Pieza de techo	Top	1	401	514	15	A
07	Prateleiras soltas	Estanterías suelta	Loose shelf	4	370	430	15	A
08	Costa	Pieza del fondo	Back panel	1	2060	390	3	A
09	Porta menor	Puerta más pequeña	Small door	1	728	396	15	A
10	Porta maior	Puerta mayor	Larger door	1	1314	396	15	A

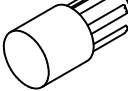
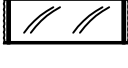

Ferragem / Herrajes / Hardware			
	Código/ Código/ Code	Descrição / Descripción / Description	Quan. / Cant. / Amou.
A	226	 Parafuso/ Tornillo/ Screw 4x40	12
B	4214	 Parafuso/ Tornillo/ Screw 3,5x14	4
C	50311	 Parafuso/ Tornillo/ Screw 5,0x65	6
D	491	 Parafuso/ Tornillo/ Screw 4x25	6
E	56243	 Parafuso/ Tornillo/ Screw 3,5x12 ZB	4
F	107	 Prego/Clavo/Nail 10x10	53
G	1802	 Cavilha/Tarugo/Peg 6x30mm	12
H	17024	 Suporte aéreo zb/Soporte de seguridad/Safety bracket	2
I	6959	 Capa para suporte branca/Cubierta de soporte/Support cover	2
J	529	 Bucha invasa/Adapter sleeve/ Manga del adaptador	4
K	58	 Etiqueta marca/Tag label "Kappesberg"	1
L	51433	 Pézinho apolo/Perrito/Foot counter Champagne	4
M	FROW =51255 (Freijo)	 Tapa furo/Tapa del agujero/Tap hole 13mm	18

N	53010	 Puxador de chapa nox/Asar/Handle Champagne	2
O	62432	 Dobradiça reta/Bisangra/Hinge 35mm	5
P	62434	 Calço para dobradiça/Calso/Shim	5
Q	62436	 Parafuso da dobradiça/ Tornillo del bisangra/Hinge screw 4,0x12	20
R	40534	 Silicone/Silicona/ Selecone 10x10	2
S	118	 Suporte para prateleira/Soporte de estante/Shelf support	24
T	41	 Cola branca em bispnaga/Cola blanca/White glue (10g)	1
01 Saco pequeno para acessórios			
01 Saco médio para puxadores			



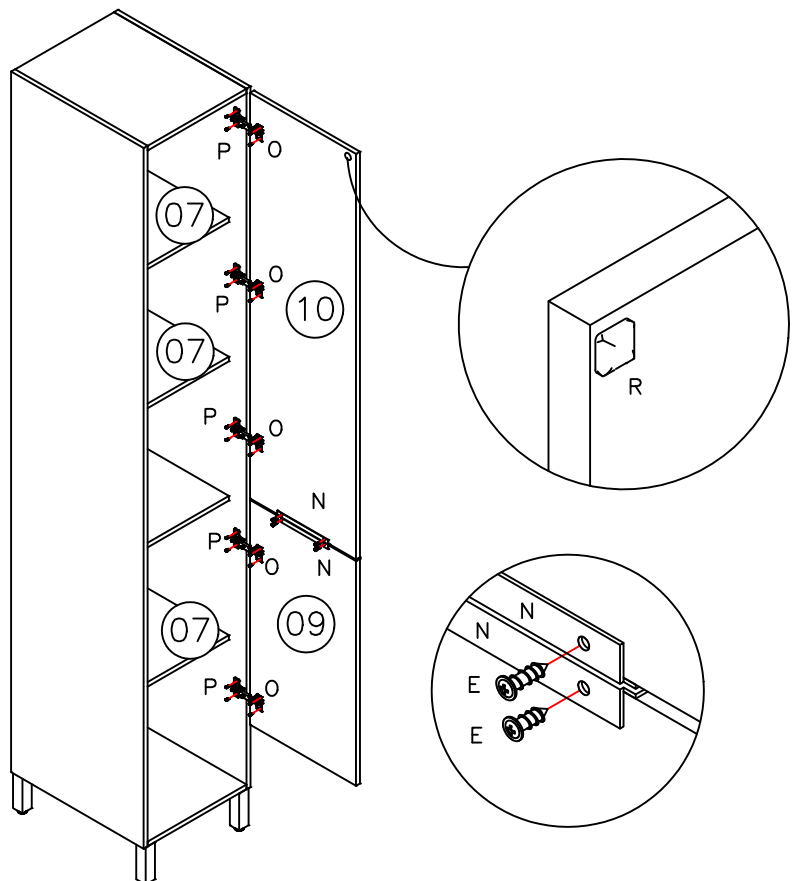
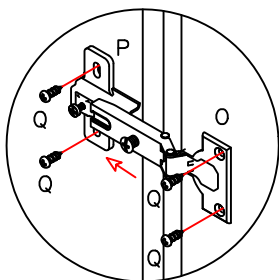
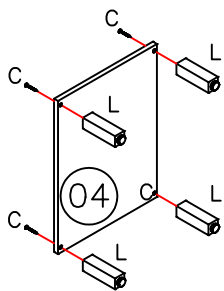
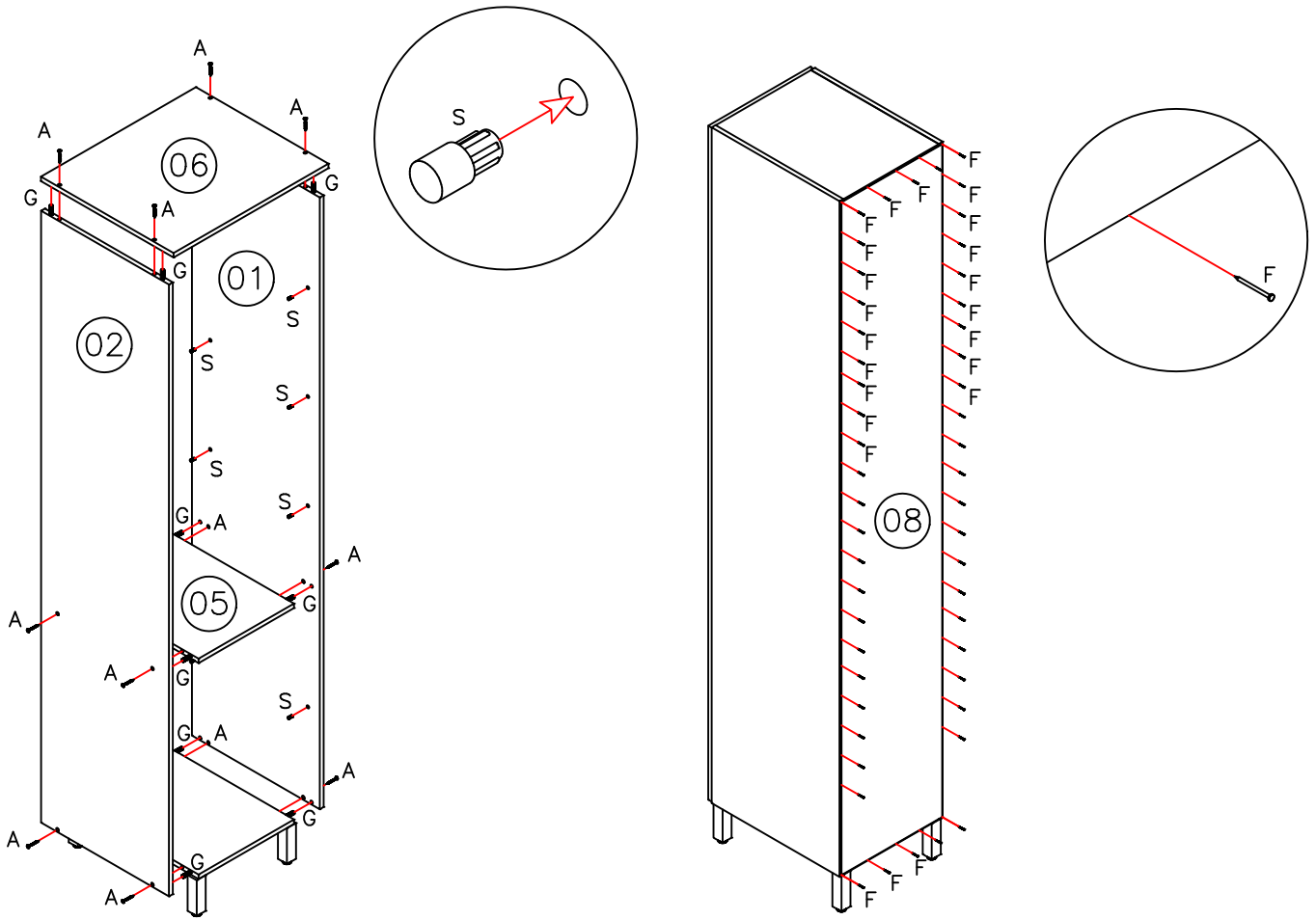

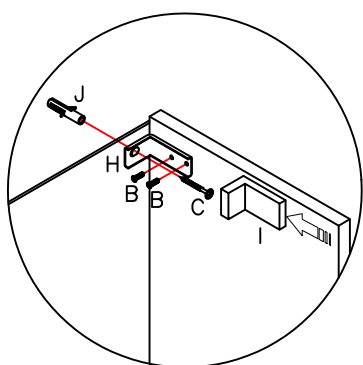

Para montar a cozinha suspensa:

- Utilize o sarrafo de apoio (03) que acompanha o móvel como apoio para sua fixação na parede, utilizando a bucha "J" e o parafuso "C".
- Em uma lateral fixe um suporte aéreo metalizado "H" com o parafuso "B" e na parede com o parafuso "C" e com a bucha "J".
- Coloque uma capa "I" em cada suporte "H".

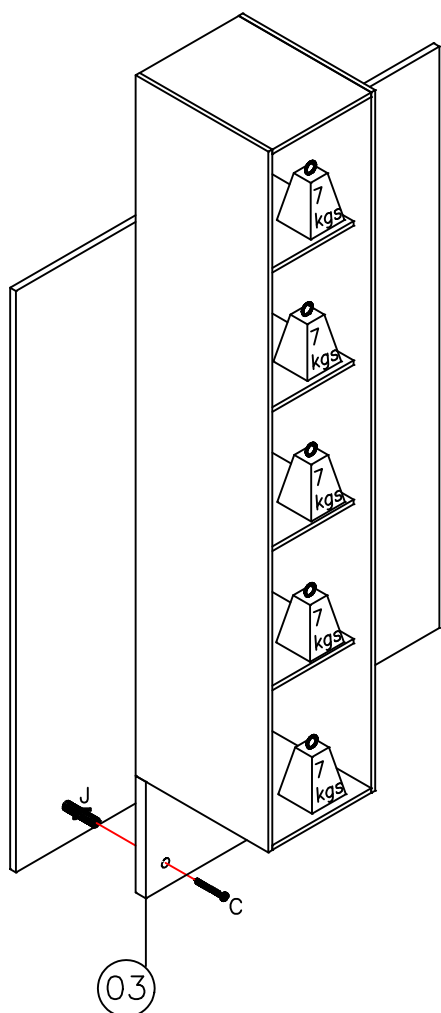

Para montar la cocina suspendida:

- Use el marco de apoyo (03) que viene con los muebles como soporte para su montaje en la pared utilizando el casquillo "J" y el tornillo "C".
- Por un lado, fije un soporte neumático metálico "H" con el tornillo "B" y la pared con el tornillo "C" y el casquillo "J".
- Coloque una cubierta "I" en cada soporte "H".

To mount the kitchen suspended:

- Use the support slat (03) board that comes with the furniture as a support for its wall mounting using the "J" bush and the "C" screw.
- On one side, fix a metallic air support "H" with the screw "B" and the wall with the screw "C" and the bushing "J".
- Place a "I" cover on each "H" bracket.

MANUAL DE MONTAGEM

INSTRUCCIONES DE MONTAJE

ASSEMBLY INSTRUCTIONS

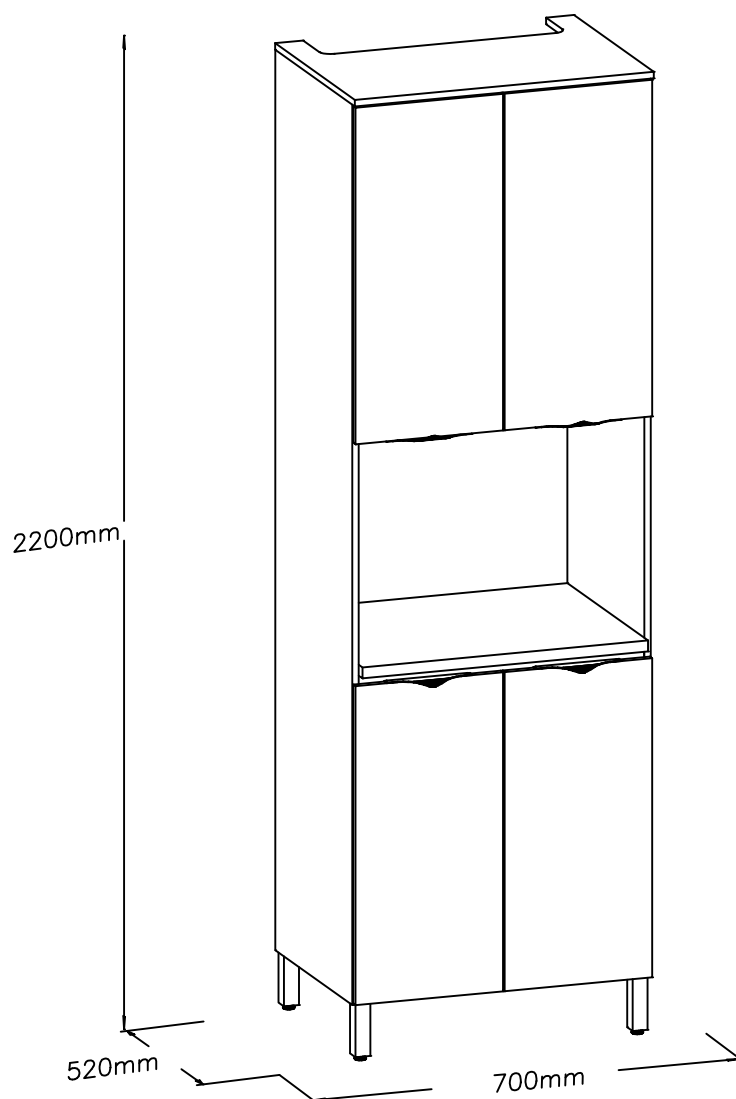

ATENÇÃO / PRECAUCIÓN / ATTENTION:

- 1 – Ler atentamente todo o manual antes de iniciar a montagem do móvel.
- 2 – A montagem deve ser feita em uma superfície plana e limpa.
- 3 – Recomenda-se utilizar a embalagem do móvel para forrar e chão e assim não danificá-lo.
 - 1 – Lea cuidadosamente todo el manual antes de comenzar el montaje.
 - 2 – La instalación debe hacerse sobre una superficie plana y limpia.
 - 3 – Recomanda ser utilizado para empaquetar móvel a la línea y tierra y por lo tanto dañar ellos.
- 1 – Read the entire manual carefully before starting the furniture assembly.
- 2 – The assembly must be done on a flat and clean surface.
- 3 – It is recommended to use the packaging of the furniture to cover and floor and thus not to damage them.

LIMPEZA E CONSERVAÇÃO / LIMPIEZA Y CONSERVACIÓN / CLEANLINESS AND CONSERVATION:

A limpeza do móvel deve ser feita com utilização de pano umedecido com água, podendo conter uma pequena quantidade de álcool. Não utilize produtos abrasivos.

La unidad de limpieza se debe realizar con el uso de paño humedecido con agua y puede contener una pequeña cantidad de alcohol. No utilice productos abrasivos.

The furniture should be cleaned with a cloth dampened with water and may contain a small amount of alcohol. Do not use abrasive products.

GARANTIA / GARANTÍA / WARRANTY:

90 dias para defeitos de fabricação.

90 días a defectos de fabricación.

90 days for manufacturing defects.

FERRAMENTAS NECESSÁRIAS / HERRAMIENTAS NECESARIAS / TOOLS REQUIRED:

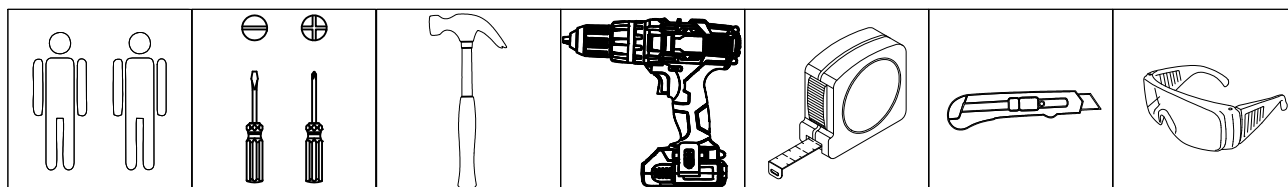

Acesse as dicas de
montagem no Youtube

Accede a los consejos de
montaje en Youtube.

Access the mounting tips on
Youtube.

www.youtube.com/MoveisKappesberg







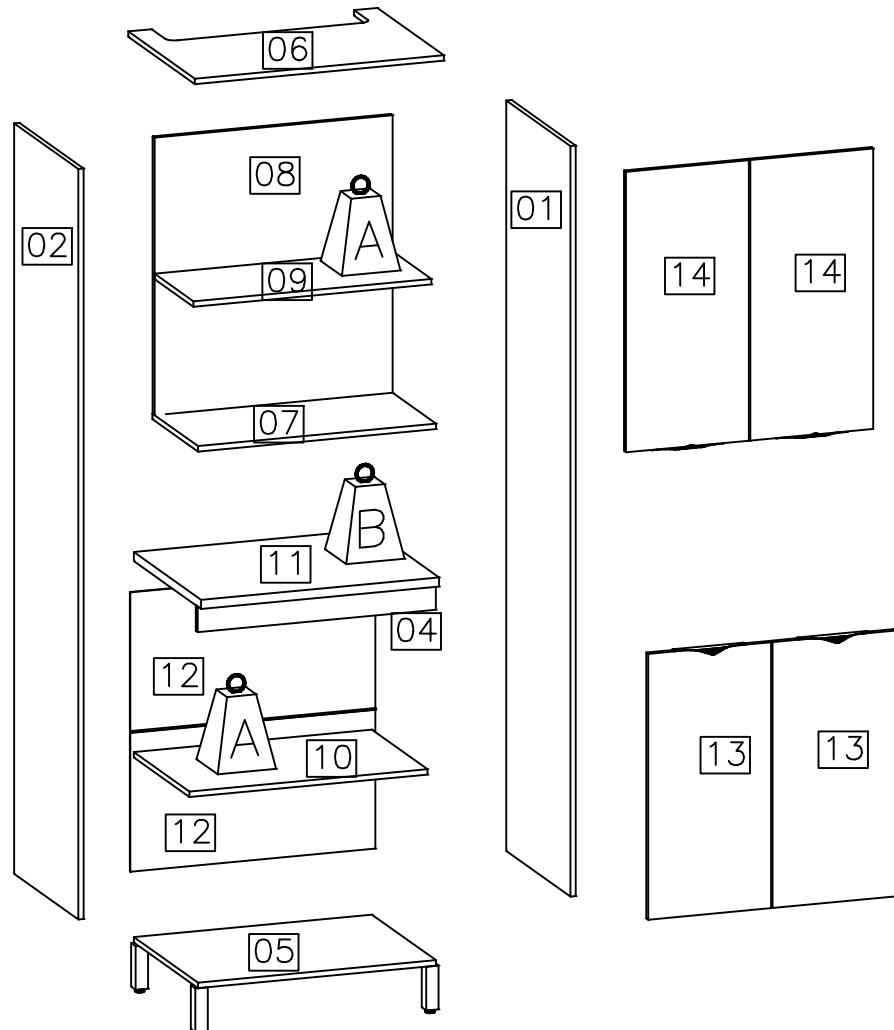





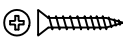

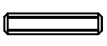

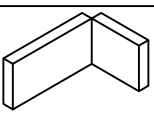
Lista de peças / Lista de piezas / List of pieces

Código/ Código/ Code	Descrição	Descripción	Description	Quantidade/ Cantidad/ Amount	Comprimento/ Longitud/ Length (mm)	Largura/ Ancho/ Width (mm)	Espessura/ Espesor/ Thickness (mm)	Caixa/ Caja/ Box
01	Lateral direita	Lateral derecha	Right side	1	2055	496	15	A
02	Lateral esquerda	Lateral izquierda	Left side	1	2055	496	15	A
03	Sarrafo de apoio	Marco de apoyo	Support slat	1	690	50	15	B
04	Travessa frontal	Travesaño delantero	Front cross-piece	1	670	70	15	A
05	Base	Pieza de suelo	Base	1	670	496	15	A
06	Chapéu	Pieza de techo	Top	1	701	514	15	B
07	Base do aéreo	Pieza superior	Top piece	1	670	352	15	B
08	Costa do aéreo	Pieza trasera	Back piece	1	670	760	15	B
09	Prateleira do armário	Estante de gabinete	Cabinet shelf	1	670	300	15	B
10	Prateleira do balcão	Estante	Shelf	1	670	430	15	A
11	Tampo	Tapa del cajón	Top of drawers	1	670	520	25	B
12	Costas inferiores	Pieza inferior del fondo	Lower bottom part	2	690	380	3	B
13	Porta inferior	Puerta inferior	Bottom door	2	728	346	15	B
14	Porta superior	Puerta superior	Top door	2	768	346	15	B

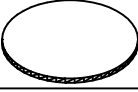
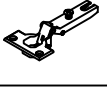

	Kg	lb
A	7	15.43lb
B	20	44.09lb

Ferragem / Herrajes / Hardware			
	Código/ Código/ Code	Descrição / Descripción / Description	Quan. / Cant. / Amou.
A	226	 Parafuso/ Tornillo/ Screw 4x40	32
B	4214	 Parafuso/ Tornillo/ Screw 3,5x14	6
C	50311	 Parafuso/ Tornillo/ Screw 5,0x65	6
D	491	 Parafuso/ Tornillo/ Screw 4x25	6
E	56243	 Parafuso/ Tornillo/ Screw 3,5x12 ZB	8
F	107	 Pregos/Clavo/Nail 10x10	22
G	1802	 Cavilha/Tarugo/Peg 6x30mm	26
H	17024	 Suporte aéreo zb/Soporte de seguridad/Safety bracket	2
I	6959	 Capa para suporte branca/Cubierta de soporte/Support cover	2
J	529	 Bucha invasa/Adapter sleeve/ Manga del adaptador	4
K	58	 Etiqueta marca/Tag label "Kappesberg"	1
L	51433	 Pézinho apolo/Perrito/Foot counter Champagne	4
M	53010	 Puxador de chapa nox/Asar/Handle Champagne	4
N	FROW =51255 (Freijo)	 Tapa furo/Tapa del agujero/Tap hole 13mm	32
O	62432	 Dobradiça reta/Bisagra/Hinge 35mm	8
P	62434	 Calço para dobradiça/Calso/Shi m	8

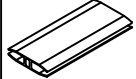
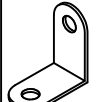
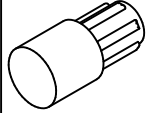
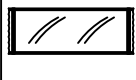
Q	62436		Parafuso da dobradiça/ Tornillo del bisagra/Hinge screw 4,0x12	32
R	40534		Silicone/Silicona/ Selecone 10x10	6
S	FROW=14991 (Carvalle)		Perfil H/Perfil de acabado/Finishing profile 670mm	1
T	85		"L" de metal/Cantón "L" de metal/Metal angle bracket "L"	1
U	118		Suporte para prateleira/Soporte de estante/Shelf support	6
V	41		Cola branca em bisenaga/Cola blanca/White glue (10g)	1
01 Saco médio para acessórios				
01 Saco médio para puxadores				



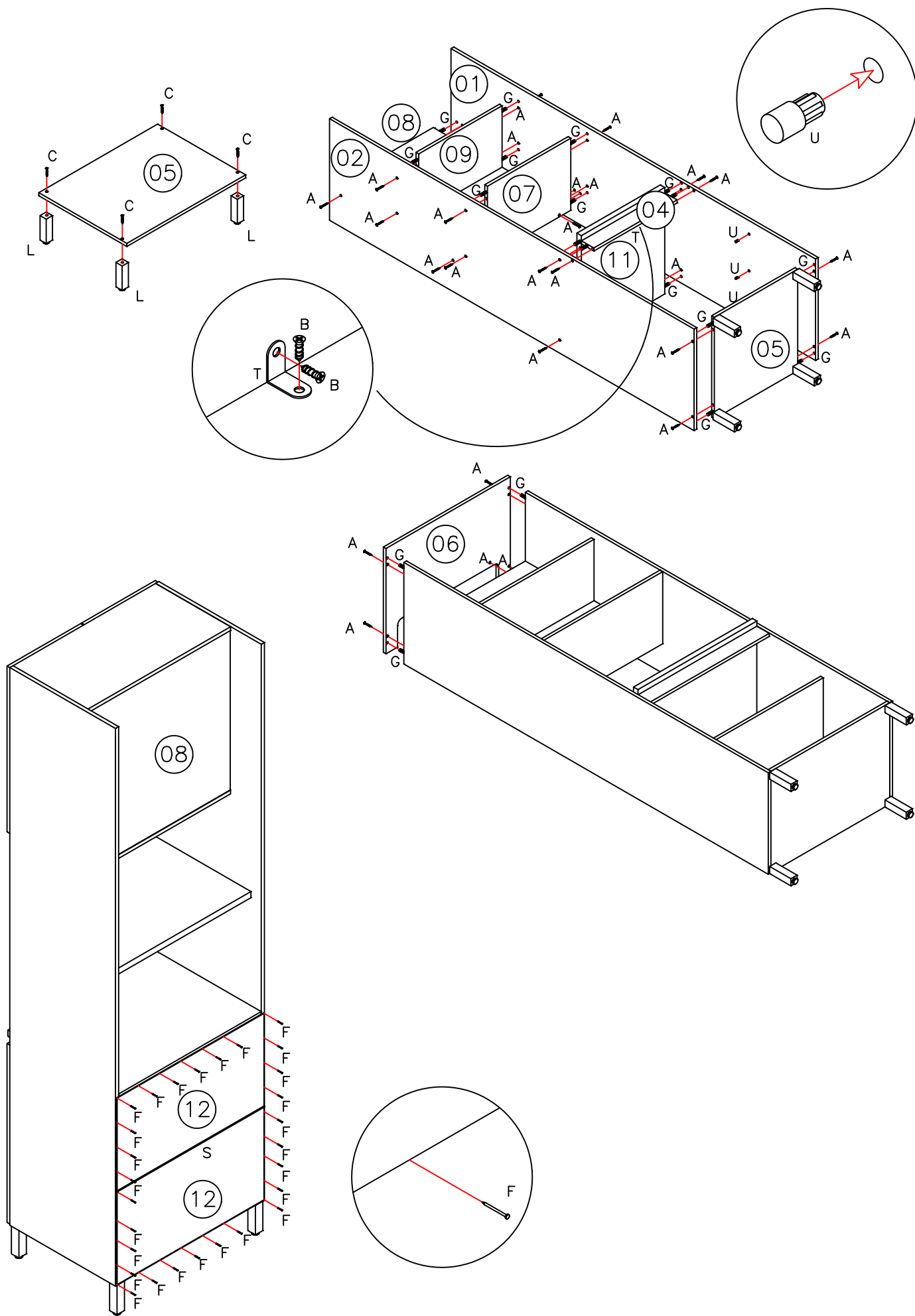

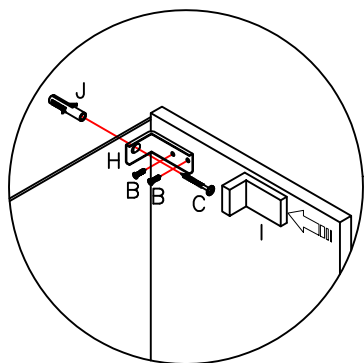
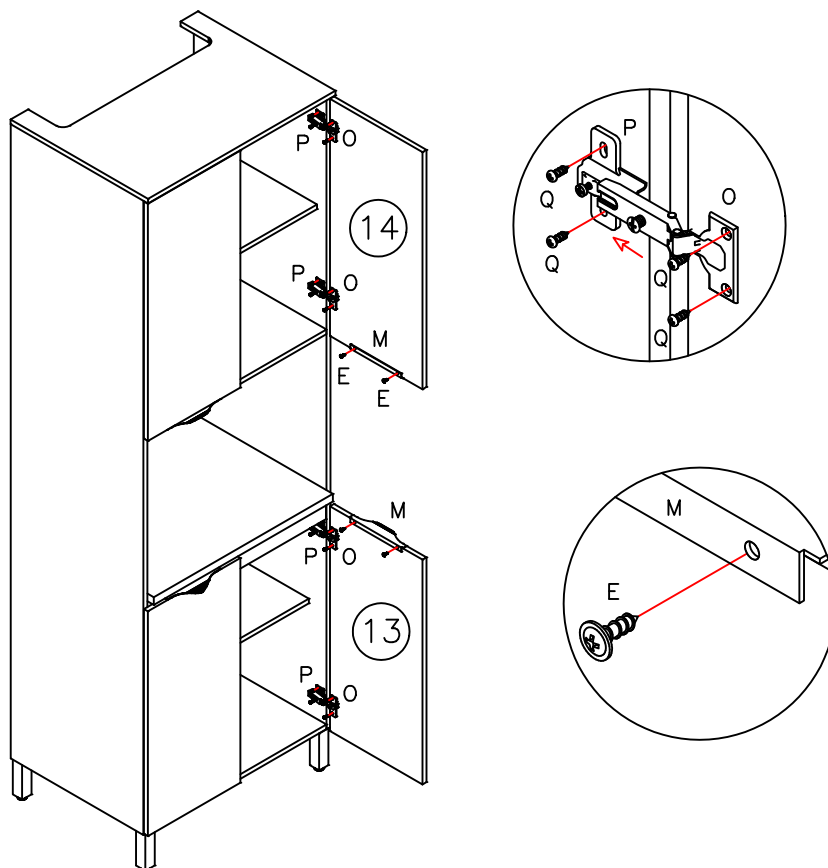

Para montar a cozinha suspensa:

- Utilize o sarrafo de apoio (03) que acompanha o móvel como apoio para sua fixação na parede, utilizando a bucha "J" e o parafuso "C".
- Em uma lateral fixe um suporte aéreo metalizado "H" com o parafuso "B" e na parede com o parafuso "C" e com a bucha "J".
- Coloque uma capa "I" em cada suporte "H".

Para montar la cocina suspendida:

- Use el marco de apoyo (03) que viene con los muebles como soporte para su montaje en la pared utilizando el casquillo "J" y el tornillo "C".
- Por un lado, fije un soporte neumático metálico "H" con el tornillo "B" y la pared con el tornillo "C" y el casquillo "J".
- Coloque una cubierta "I" en cada soporte "H".

To mount the kitchen suspended:

- Use the support slat (03) board that comes with the furniture as a support for its wall mounting using the "J" bush and the "C" screw.
- On one side, fix a metallic air support "H" with the screw "B" and the wall with the screw "C" and the bushing "J".
- Place a "I" cover on each "H" bracket.

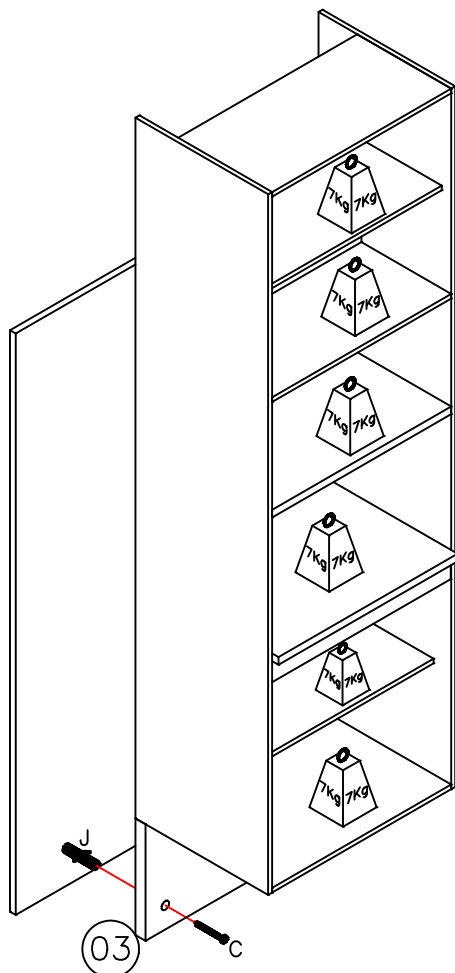

MANUAL DE MONTAGEM

INSTRUCCIONES DE MONTAJE

ASSEMBLY INSTRUCTIONS

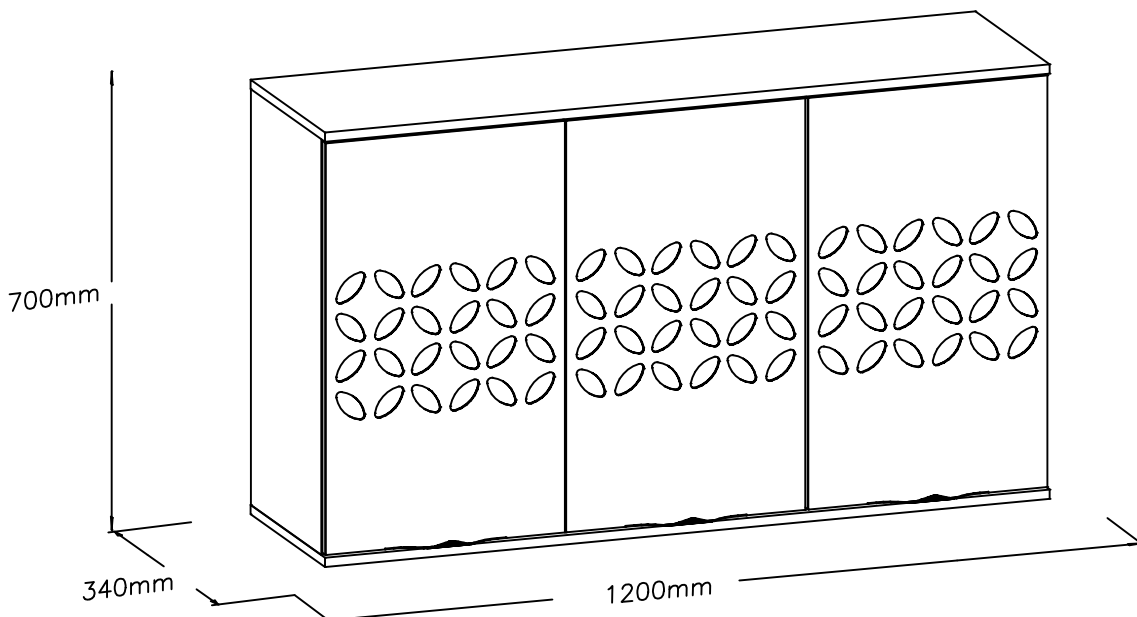

ATENÇÃO / PRECAUCIÓN / ATTENTION:

- 1 – Ler atentamente todo o manual antes de iniciar a montagem do móvel.
- 2 – A montagem deve ser feita em uma superfície plana e limpa.
- 3 – Recomenda-se utilizar a embalagem do móvel para forrar e chão e assim não danificá-lo.
 - 1 – Lea cuidadosamente todo el manual antes de comenzar el montaje.
 - 2 – La instalación debe hacerse sobre una superficie plana y limpia.
 - 3 – Recomanda ser utilizado para empaquetar móbil a la línea y tierra y por lo tanto dañar ellos.
- 1 – Read the entire manual carefully before starting the furniture assembly.
- 2 – The assembly must be done on a flat and clean surface.
- 3 – It is recommended to use the packaging of the furniture to cover and floor and thus not to damage them.

LIMPEZA E CONSERVAÇÃO / LIMPIEZA Y CONSERVACIÓN / CLEANLINESS AND CONSERVATION:

A limpeza do móvel deve ser feita com utilização de pano umedecido com água, podendo conter uma pequena quantidade de álcool. Não utilize produtos abrasivos.

La unidad de limpieza se debe realizar con el uso de paño humedecido con agua y puede contener una pequeña cantidad de alcohol. No utilice productos abrasivos.

The furniture should be cleaned with a cloth dampened with water and may contain a small amount of alcohol. Do not use abrasive products.

GARANTIA / GARANTÍA / WARRANTY:

90 dias para defeitos de fabricação.

90 días a defectos de fabricación.

90 days for manufacturing defects.

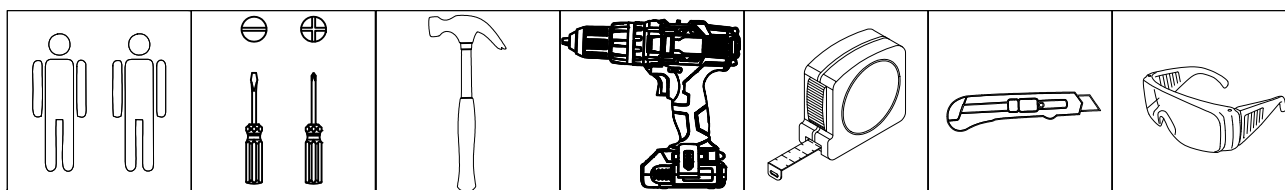
FERRAMENTAS NECESSÁRIAS / HERRAMIENTAS NECESARIAS / TOOLS REQUIRED:

Acesse as dicas de
montagem no Youtube

Accede a los consejos de
montaje en Youtube.

Access the mounting tips on
Youtube.

www.youtube.com/MoveisKappesberg



Lista de peças / Lista de piezas / List of pieces

Código/ Código/ Code	Descrição	Descripción	Description	Quantidade/ Cantidad/ Amount	Comprimento/ Longitud/ Length (mm)	Largura/ Ancho/ Width (mm)	Espessura/ Espesor/ Thickness (mm)	Caixa/ Caja/ Box
01	Lateral direita	Lateral derecha	Right side	1	670	320	15	A
02	Lateral esquerda	Lateral izquierda	Left side	1	670	320	15	A
03	Divisória	División	Division	1	670	320	15	A
04	Prateleiras maior	Estanterías mayor	Shelf larger	1	769	320	15	A
05	Prateleiras menor	Estantería pequeña	Smaller shelf	1	385	320	15	A
06	Base	Pieza de suelo	Base	1	1200	338	15	A
07	Chapéu	Pieza de techo	Top	1	1200	338	15	A
08	Costa	Pieza del fondo	Back panel	2	1190	345	3	A
10	Portas	Puertas	Doors	3	663	396	15	A

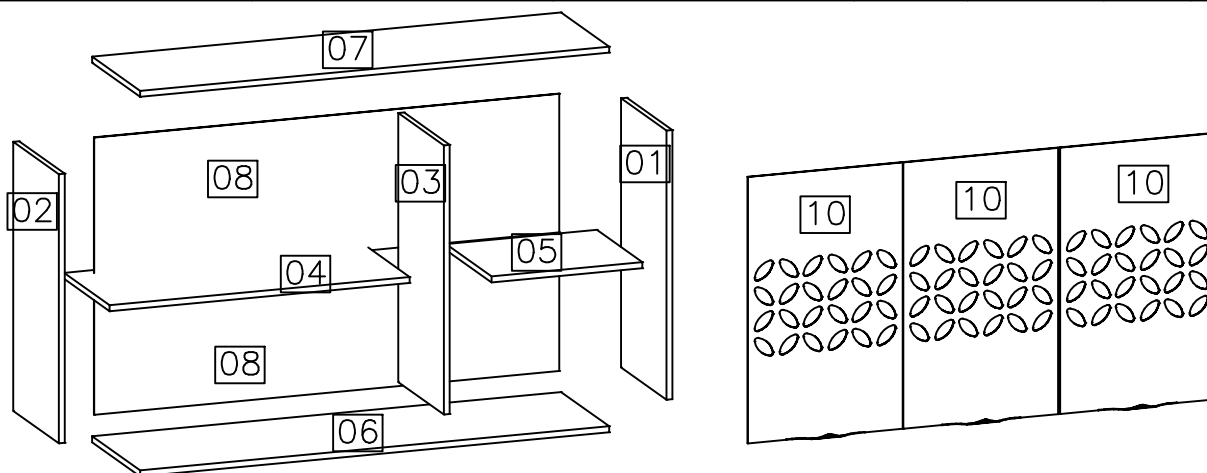

Ferragem / Herrajes / Hardware

	Código/ Código/ Code	Descrição / Descripción / Description	Quan. / Cant. / Amou.
A	226	Parafuso/ Tornillo/ Screw 4x40	18
B	4214	Parafuso/ Tornillo/ Screw 3,5x14	12
C	50311	Parafuso/ Tornillo/ Screw 5,0x65	6
D	491	Parafuso/ Tornillo/ Screw 4x25	4
E	30945	Parafuso Minifix/ Tornillo/ Screw	1
F	30950	Tambor Minifix/Cilindro/Drum	1
G	107	Pregos/Clavos/Nails 10x10	37
H	1802	Cavilha/Tarugo/Peg 6x30mm	16
I	1925	Cavilha/Tarugo/Peg 6x50mm	2
J	17024	Suporte aéreo zb/Soporte de seguridad/Safety bracket	6
K	6959	Capa para suporte branca/Cubierta de soporte/Support cover	6
L	529	Bucha invasiva/Adapter sleeve/ Manga del adaptador	6

M	58	Etiqueta marca/Tag label "Kappesberg"	1
N	FR0W=51255 (Freijo)	Tapa furo/Tapa del agujero/Tap hole 13mm	18
O	FR0W=51256 (Freijo)	Tapa furo/Tapa del agujero/Tap hole 19mm	1
P	62432	Dobradiça reta/Bisagra/Hinge 35mm	6
Q	62434	Calço para dobradiça/Calso/Shim	6
R	62436	Parafuso da dobradiça/ Tornillo del bisagra/Hinge screw 4,0x12	24
S	56243	Parafuso/ Tornillo/ Screw 3,5x12 ZB	6
T	41	Cola branca em bisnaga/Cola blanca/White glue (10g)	1
U	40534	Silicone/Silicona/ Selecone 10x10	4
V	1423	Fixador de costa/Fijador de costa/Shore Fixer	8
W	53010	Puxador de chapa nox/Asar/Handle Champagne	3
01 Saco pequeno para puxador			
01 Saco médio para acessórios			



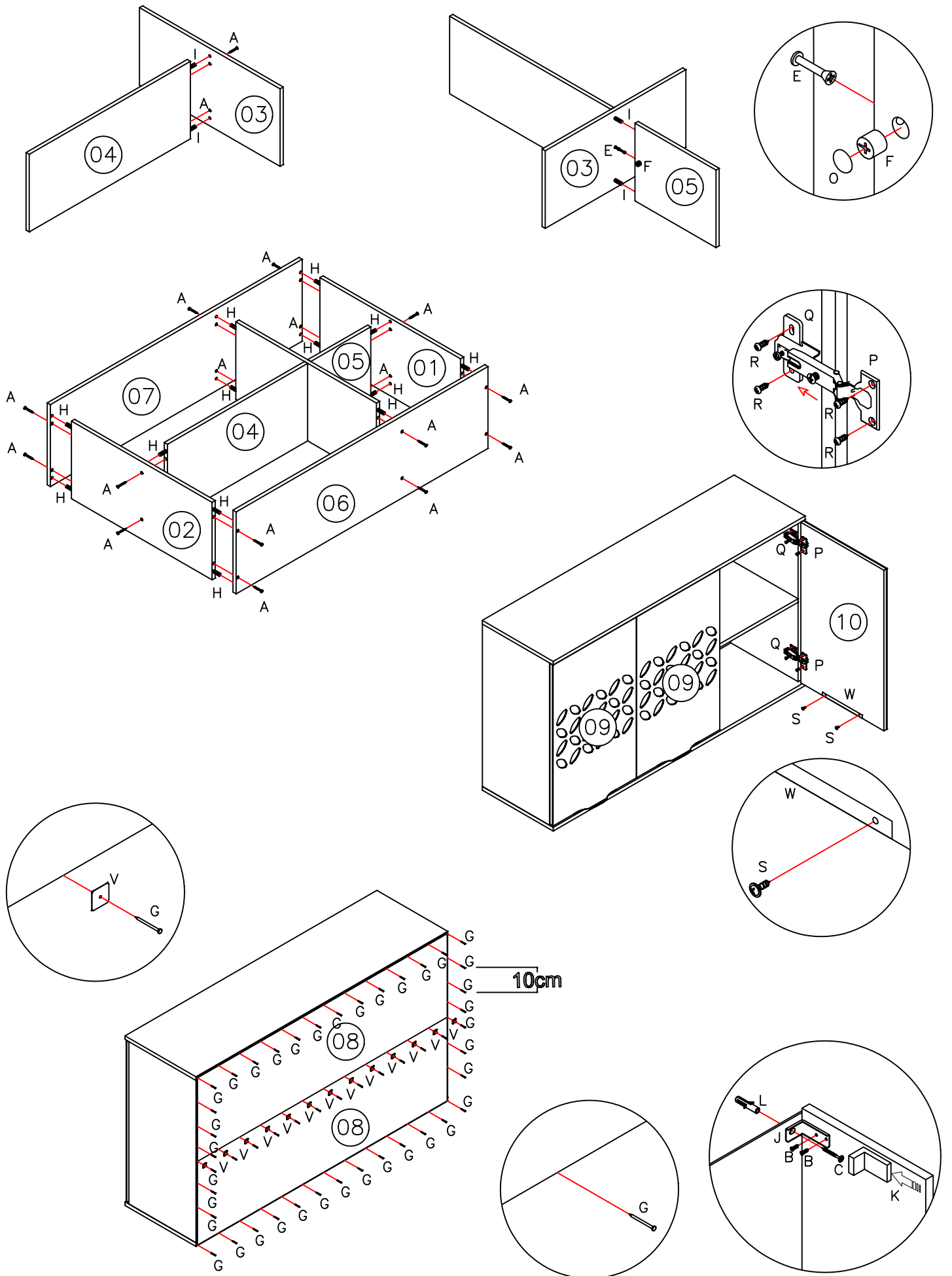

MANUAL DE MONTAGEM

INSTRUCCIONES DE MONTAJE

ASSEMBLY INSTRUCTIONS

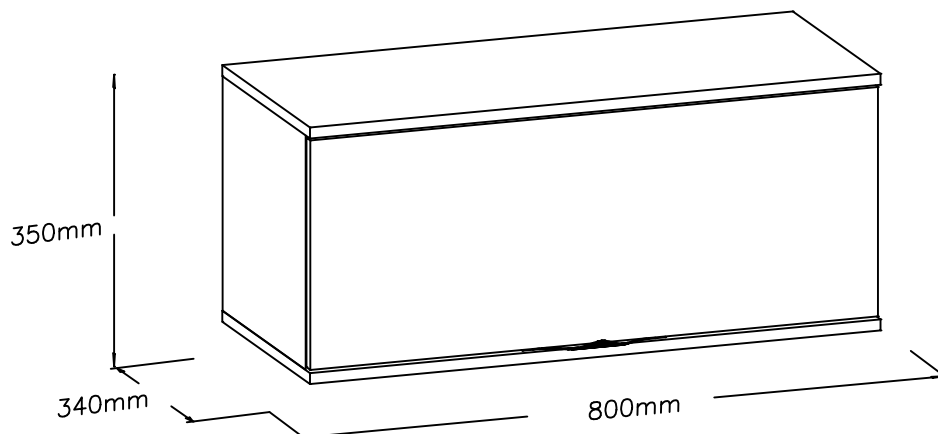

ATENÇÃO / PRECAUCIÓN / ATTENTION:

- 1 – Ler atentamente todo o manual antes de iniciar a montagem do móvel.
- 2 – A montagem deve ser feita em uma superfície plana e limpa.
- 3 – Recomenda-se utilizar a embalagem do móvel para forrar e chão e assim não danificá-lo.
 - 1 – Lea cuidadosamente todo el manual antes de comenzar el montaje.
 - 2 – La instalación debe hacerse sobre una superficie plana y limpia.
 - 3 – Recomanda ser utilizado para empaquetar móbil a la línea y tierra y por lo tanto dañar ellos.
- 1 – Read the entire manual carefully before starting the furniture assembly.
- 2 – The assembly must be done on a flat and clean surface.
- 3 – It is recommended to use the packaging of the furniture to cover and floor and thus not to damage them.

LIMPEZA E CONSERVAÇÃO / LIMPIEZA Y CONSERVACIÓN / CLEANLINESS AND CONSERVATION:

A limpeza do móvel deve ser feita com utilização de pano umedecido com água, podendo conter uma pequena quantidade de álcool. Não utilize produtos abrasivos.

La unidad de limpieza se debe realizar con el uso de paño humedecido con agua y puede contener una pequeña cantidad de alcohol. No utilice productos abrasivos.

The furniture should be cleaned with a cloth dampened with water and may contain a small amount of alcohol. Do not use abrasive products.

GARANTIA / GARANTÍA / WARRANTY:

90 dias para defeitos de fabricação.

90 días a defectos de fabricación.

90 days for manufacturing defects.

FERRAMENTAS NECESSÁRIAS / HERRAMIENTAS NECESARIAS / TOOLS REQUIRED:

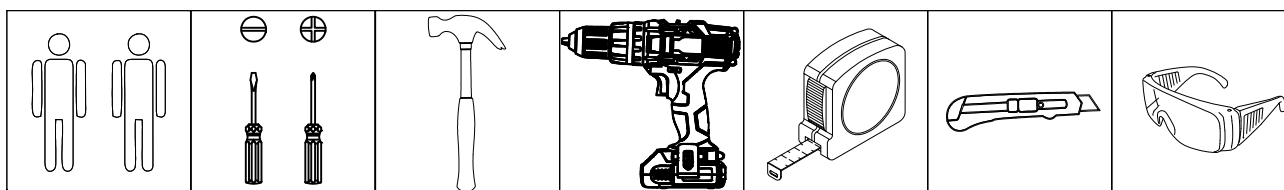

Acesse as dicas de
montagem no Youtube

Accede a los consejos de
montaje en Youtube.

Access the mounting tips on
Youtube.

www.youtube.com/MoveisKappesberg



Lista de peças / Lista de piezas / List of pieces

Código/ Código/ Code	Descrição	Descripción	Description	Quantidade/ Cantidad/ Amount	Comprimento/ Longitud/ Length (mm)	Largura/ Ancho/ Width (mm)	Espessura/ Espesor/ Thickness (mm)	Caixa/ Caja/ Box
01	Lateral direita	Lateral derecha	Right side	1	320	320	15	A
02	Lateral esquerda	Lateral izquierda	Left side	1	320	320	15	A
03	Base	Pieza de suelo	Base	1	800	338	15	A
04	Chapéu	Pieza de techo	Top	1	800	338	15	A
05	Costa	Pieza del fondo	Back panel	1	790	345	3	A
06	Porta	Puerta	Door	1	796	313	15	A

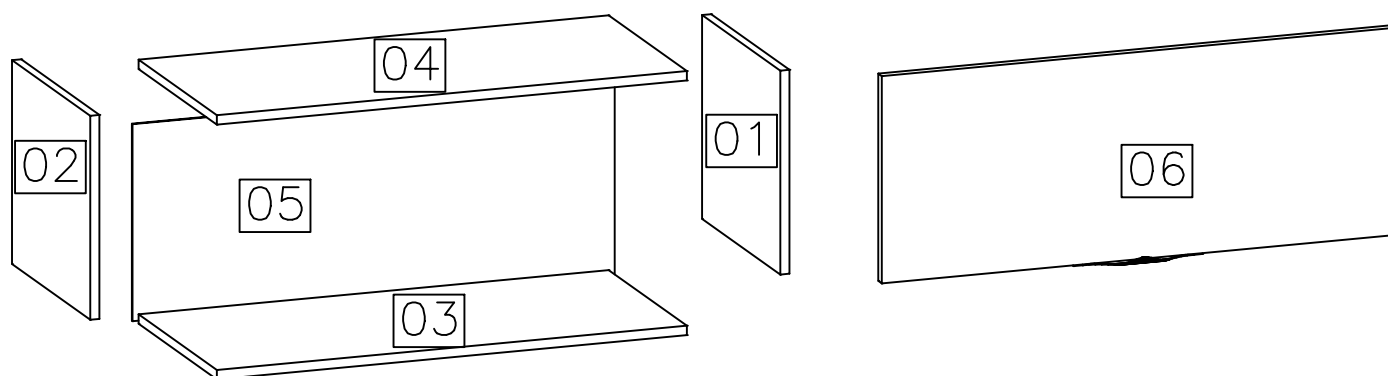

Ferragem / Herrajes / Hardware

	Código/ Código/ Code	Descrição / Descripción / Description	Quan. / Cant. / Amou.
A	226	Parafuso/ Tornillo/ Screw 4x40	8
B	4214	Parafuso/ Tornillo/ Screw 3,5x14	12
C	50311	Parafuso/ Tornillo/ Screw 5,0x65	2
D	491	Parafuso/ Tornillo/ Screw 4x25	4
E	107	Prego/Clavo/Nail 10x10	23
F	1802	Cavilha/Tarugo/Peg 6x30mm	8
G	17024	Suporte aéreo zb/Soporte de seguridad/Safety bracket	2
H	6959	Capa para suporte branca/Cubierta de soporte/Support cover	2
I	529	Bucha invasiva/Adapter sleeve/ Manga del adaptador	2
J	58	Etiqueta marca/Tag label "Kappesberg"	1
K	53010	Puxador de chapa nox/Asar/Handle Champagne	1
L	FRW =51255 (Freijo)	Tapa furo/Tapa del agujero/Tap hole 13mm	8

M	62433	Dobradiça super curva/Bisangra/Hinge 35mm	2
N	62435	Calço para dobradiça/Calso/Shim	2
O	61971	Parafuso da dobradiça/ Tornillo del bisangra/Hinge screw 4,0x14	4
P	41	Cola branca em bisanaga/Cola blanca/White glue (10g)	1
Q	40534	Silicone/Silicona/ Selecone 10x10	2
R	35154	Pistão a gás 60N/ Pistón de gas/ Gas piston	1
S	899	Cantoneira /Cantонера /Ledge	2
T	8688	Parafuso união metálico/Tornillo de unión de metal/ Metal union bolt	4
U	56243	Parafuso/ Tornillo/ Screw 3,5x12 ZB	2
01 Saco médio para acessórios			
01 Saco médio para puxadores e pistão			



