

89 - MESA CABECEIRA DOBLE

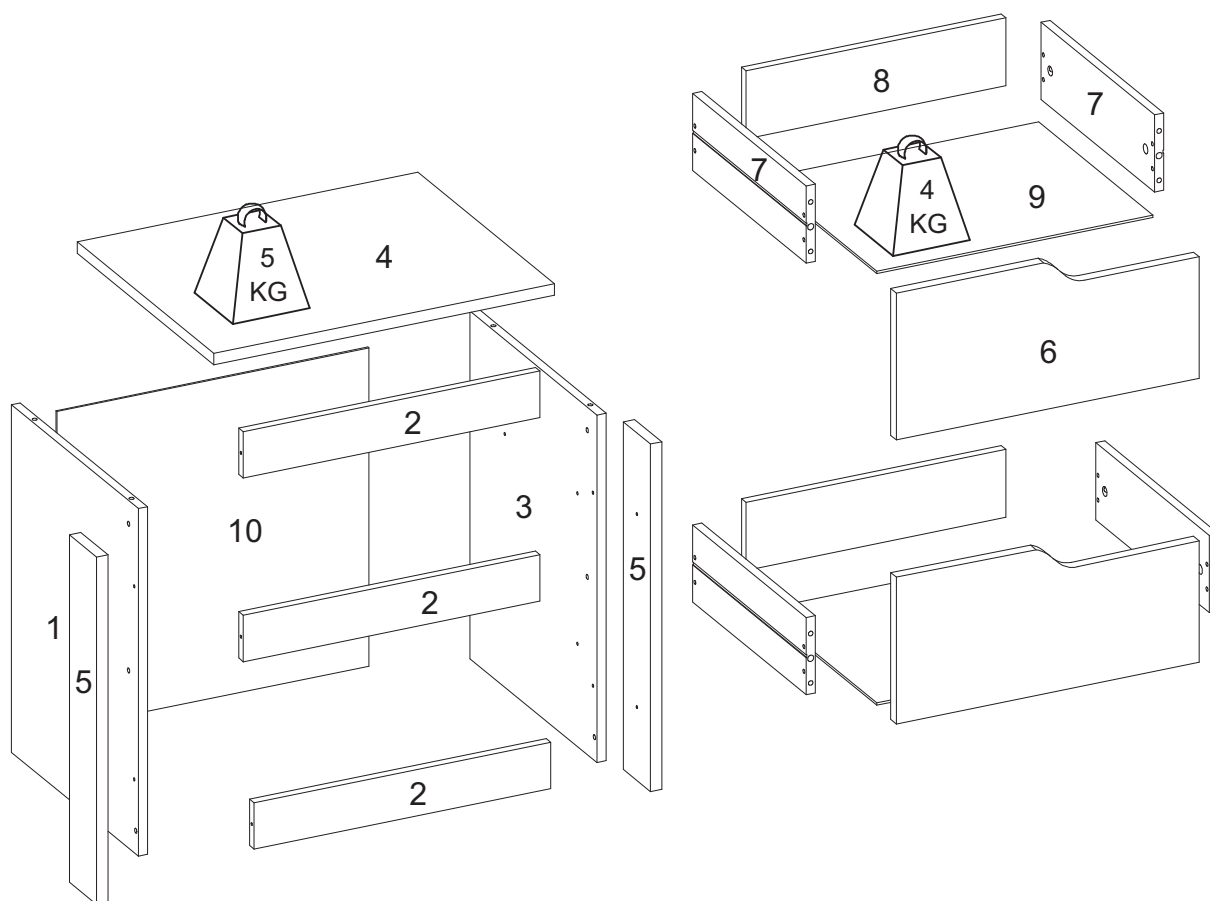

SEQ.	REF.	DESCRIÇÃO	DESCRIPTION	DESCRIPCIÓN	MAT.PRIMA	COMP.	LARG.	ESP.	QTD.
1	324233	Lateral esquerda	left side	lado izquierdo	MDP	450	336	12	1
2	324234	Vista gaveta	drawer view	vista del cajón	MDP	392	60	12	3
3	324235	Lateral direita	Right side	Lado derecho	MDP	450	336	12	1
4	324236	Tampo	Cover	Cubrir	MDP	450	361	15	1
5	324237	Vista lateral	Side view	Vista lateral	MDP	450	72	15	2
6	324238	Frente de gaveta	drawer front	frente del cajón	MDP	400	190	15	2
7	701355	Lateral de gaveta	drawer side	lado del cajón	MDP	300	100	12	4
8	324240	Contra fundo	against background	contra el fondo	MDP	343	88	12	2
9	324241	Fundo da gaveta	drawer bottom	fondo del cajón	HDF	365	302	3	2
10	324242	Fundo	Bottom	Abajo	HDF	412	412	3	1

INSTRUÇÃO MONTAGEM PRODUTO
Instructions to Assembly / Instrucciones de montaje

CUIDADO PARA CONSERVAÇÃO E LIMPEZA DO MÓVEL
Care to conservation and clean / Cuidados de limpieza

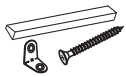

Separar as peças e acessórios de maneira organizada
Separate parts and accessories in way organized
Separar las piezas y accesorios de manera organizada

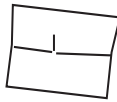

Forrar o chão com o papelão das embalagens.
Cover the floor with the cardboard
Cubra el suelo con la embalaje de cartón



É necessário 01 pessoas para montar o produto
01 people are required to assemble the product
Se requieren 01 personas para ensamblar el producto

O produto deve ser a montado por um profissional qualificado
The product must be assembly by a professional
El producto debe ser ensamblado por un professional calificado

Ferramentas necessárias
(não fornecidas)

Not include tools / No herramientas



Peso máximo de carga informado refere-se a objetos distribuído de maneira uniforme sobre toda área de contato da peça



The maximum load weight informed refers to objects distributed evenly over the entire contact area of the part
Conjunto de carga máxima de peso se refiere a objetos distribuidos uniformemente sobre toda el área de contacto de la pieza de trabajo.



Não molhar o móvel e não expor em lugar úmido
Do not wet the mobile and do not expose in a wet place
No moje el producto y no exponer en un lugar húmedo



Não expor o móvel próximo de fontes de calor.
Do not expose the mobile near heat sources
no exponga cercano de fuentes de calor



Não usar produtos abrasivos.
Do not use abrasive products.
No utilice productos abrasivos.



Limpe com flanela limpa e seca.
Clean with dry cloth
Limpieza con un paño limpio y seco

LISTA DE ACESSÓRIOS E FERRAGENS / ACCESSORIES AND HARDWARE / ACCESORIOS Y HARDWARE



A - 700137-Parafuso 4,5x45 (06x)
screw / tornillo



B- 700124-Parafuso 3,5x25 (12x)
screw / tornillo



C- 700121-Parafuso 3,5x12 (82x)
screw / tornillo



D- 700157-Prego (28x)
nail / clavo



E- 700542-Cavilha 6x30 (12x)
peg / cerrojo



F- 700146-Parafuso minifix (04x)
Minifix screw /
Tornillo minifix



G- 700148-Tambor Minifix (04x)
Minifix Drum /
Tambor minifix



H- 700419-Tapa furo minifix (08x)
minifix cover / tapa minifix



I - 700113-Corrediça (02x)
runners / corredera



J- 700539-Cantoneira (10x)
corner / esquina



K- 700448-Sapata 'L' (4x)
shoe / zapata



L - 700516-Sache cola 20g (01x)
Glue / Goma

01° PASSO - Fixar acessórios C, I e E nas peças 1 e 3
 01°STEP - Fix accessories C, I and E to parts 1 and 3
 01°PASO - Fijar los accesorios C, I y E a las partes 1 y 3

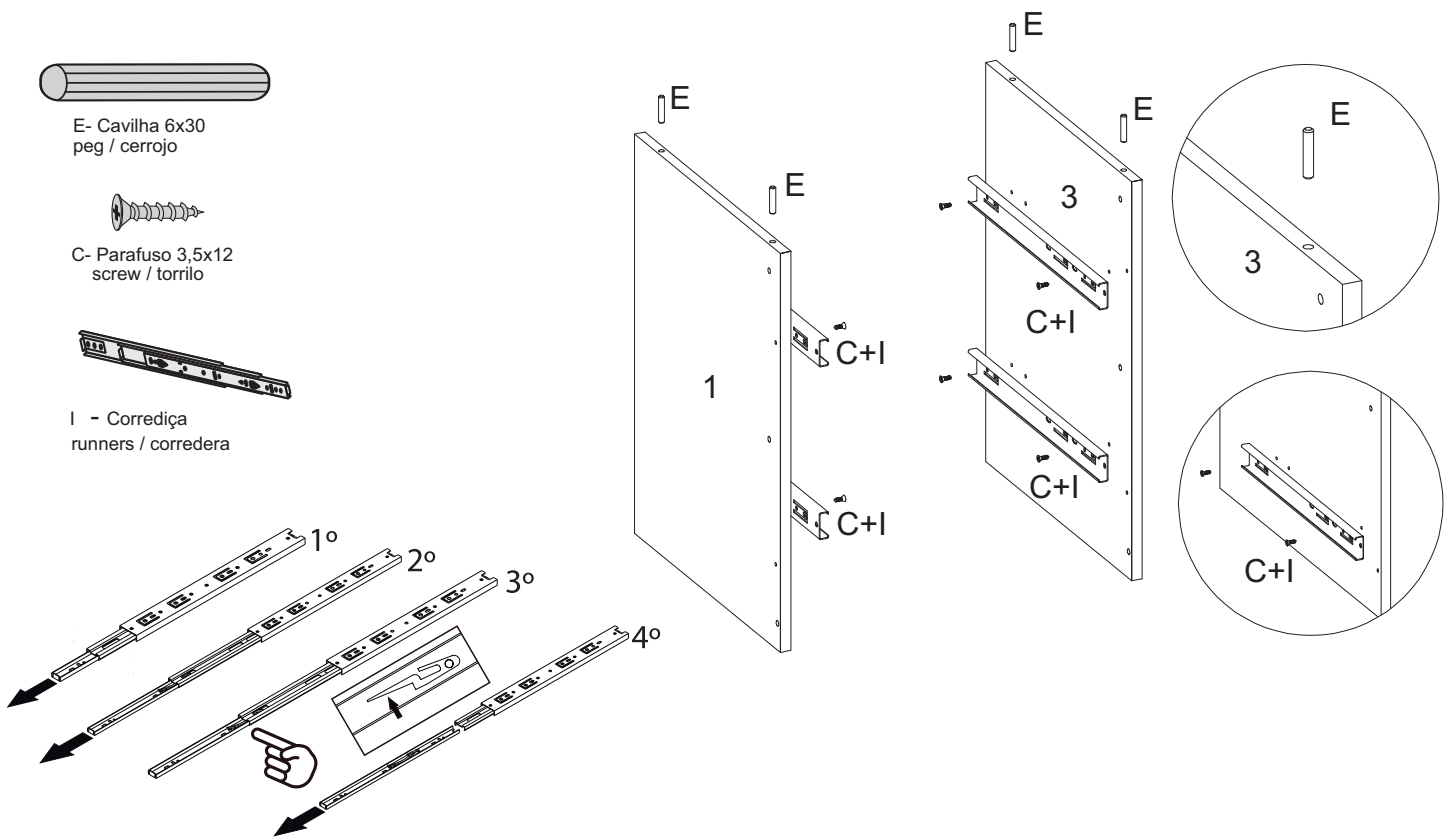

02° PASSO - Fixar a peça 4 nas peças 1 e 3
 02°STEP - Fix part 4 to parts 1 and 3
 02°PASO - Fijar la parte 4 a las partes 1 y 3

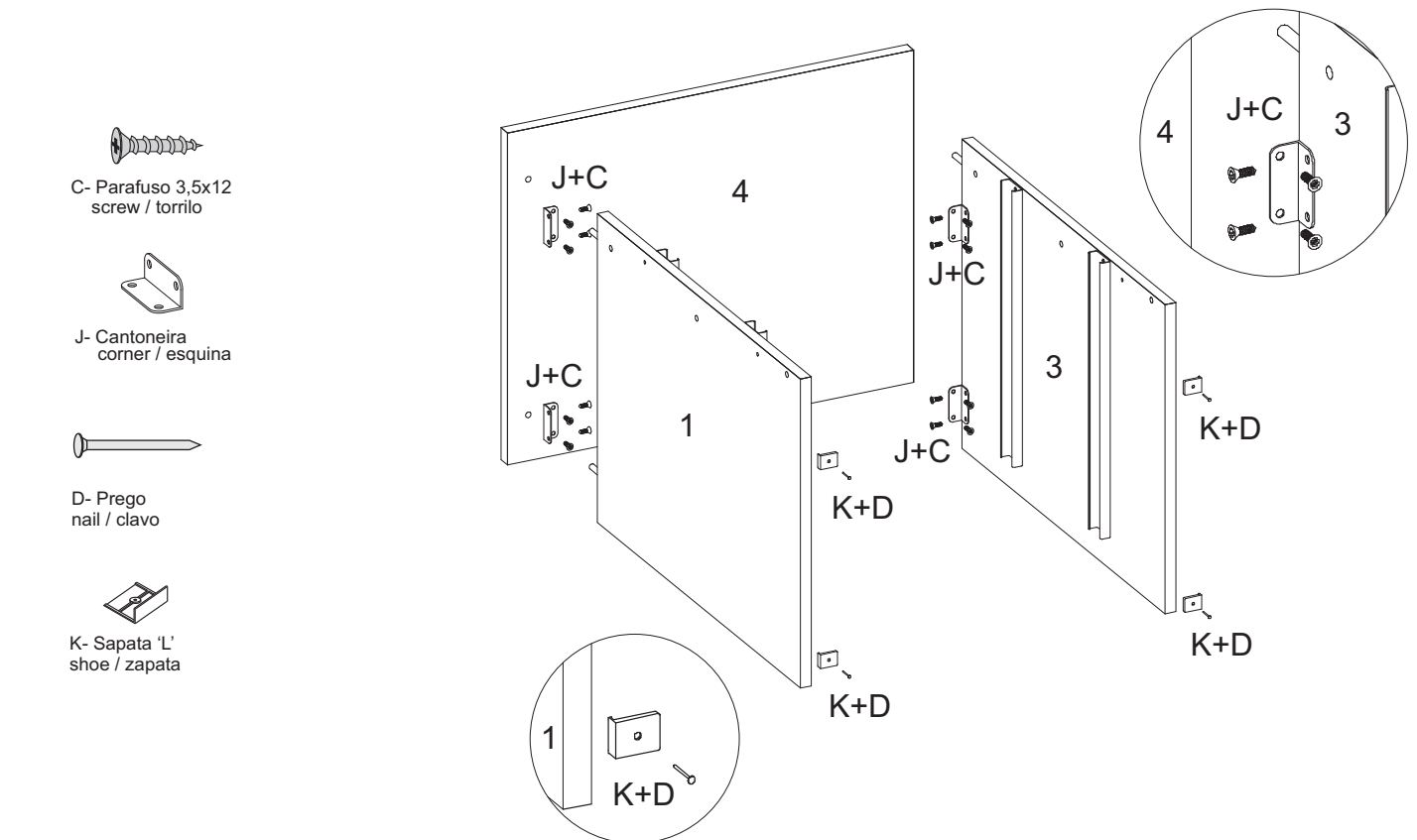

03° PASSO - Fixar as peças 2 nas peças 1 e 3
 03°STEP - Attach parts 2 to parts 1 and 3
 03°PASO - Adjunte las partes 2 a las partes 1 y 3

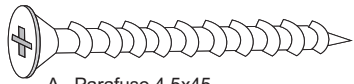

A - Parafuso 4,5x45
screw / tornillo



J- Cantoneira
corner / esquina



C- Parafuso 3,5x12
screw / tornillo

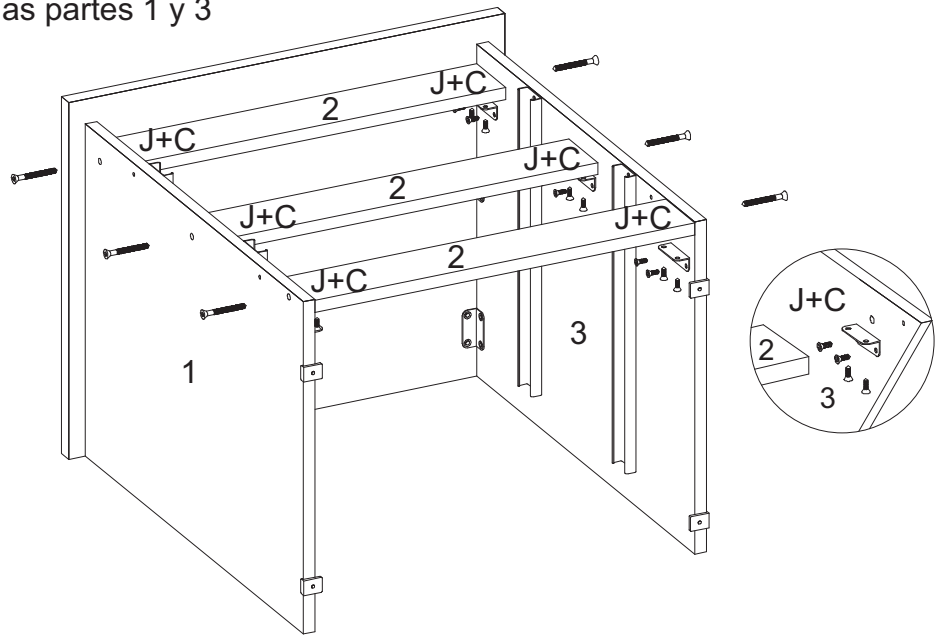

04° PASSO - Fixar as peças 5 nas peças 1 e 3
 04°STEP - Attach parts 5 to parts 1 and 3
 04°PASO - Adjunte las partes 5 a las partes 1 y 3



A - Parafuso 4,5x45
screw / tornillo

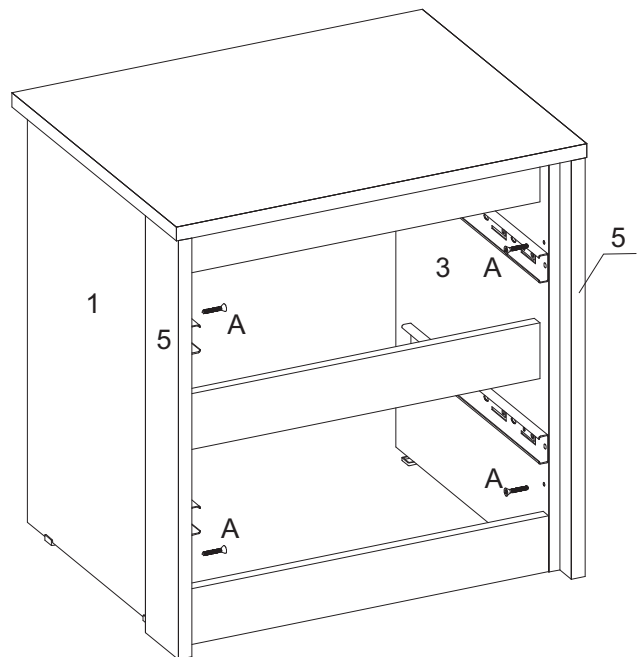

05° PASSO - Fixar a peça 10 utilizando a ferragem D
 05°STEP - Fix part 10 using hardware D
 05°PASO - Arreglar la parte 10 usando el hardware D



D- Prego
nail / clavo

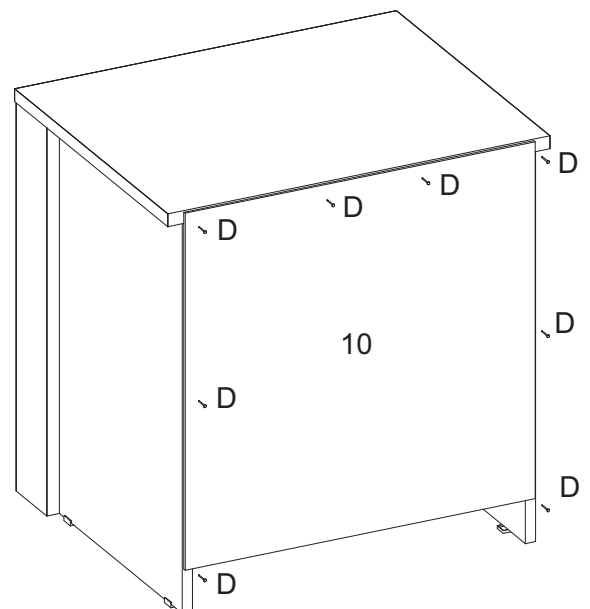

06° PASSO - Fixar as peças 6 e 8 na peça 7

06°STEP - Fix parts 6 and 8 to part 7

06°PASO - Fijar las partes 6 y 8 a la parte 7



B- Parafuso 3,5x25
screw / torrilo



E- Cavilha 6x30
peg / cerrojo



F- Parafuso minifix
Minifix screw /
Tornillo minifix



G- Tambor Minifix
Minifix Drum /
Tambor minifix



H- Tapa furo minifix
minifix cover / tapa minifix



L - Sacke cola 20g
Glue / Goma

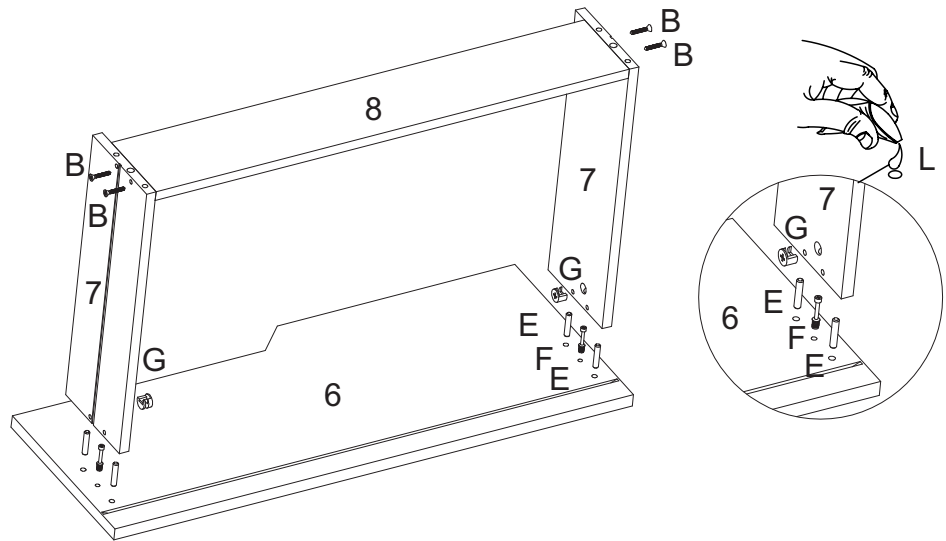

07° PASSO - Fixar a peça 9 utilizando os acessórios C e D

07°STEP - Fix part 9 using accessories C and D

07°PASO - Fijar la pieza 9 con los accesorios C y D



C- Parafuso 3,5x12
screw / torrilo



D- Prego
nail / clavo

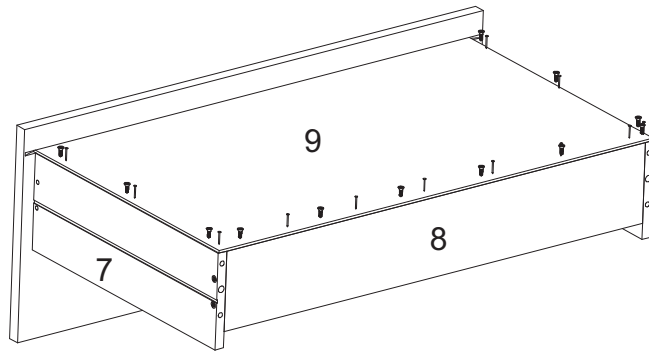

08° PASSO - Fixar o acessório I nas peças 7

08°STEP - Attach accessory I to parts 7

08°PASO - Adjunte el accesorio I a las piezas 7



C- Parafuso 3,5x12
screw / torrilo



I - Corrediça
runners / corredera

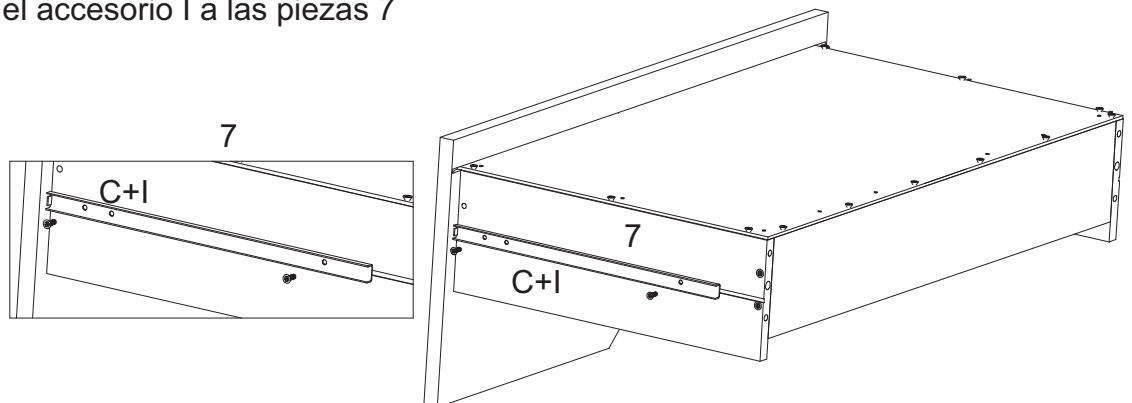

Encaixar as gavetas no produto
Fit the drawers to the product
Encajar los cajones en el producto

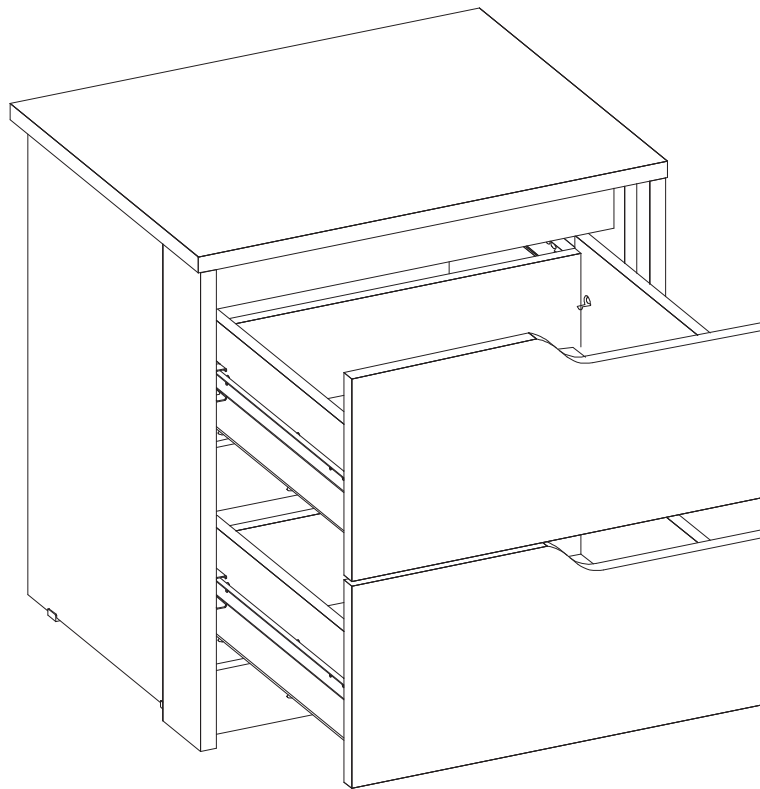

Aspecto final do produto
Final product aspect
Aspecto final del producto

