

MANUAL DE MONTAGEM / ASSEMBLY INSTRUCTIONS / PLANO DE ARMADO

Antes de montar o móvel, leia com atenção o manual de montagem!
Before assembling the furniture, carefully read the assembly instructions!
Antes de armar el mueble, lea con atención el manual de ensamble!

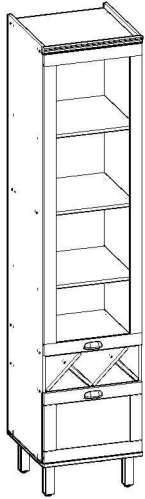

Ref.: 1515

genialflex
ambientes incríveis para todos

Parabéns! Você comprou um produto de excelente qualidade, fabricado com chapa de madeira de MDP ou MDF, extraída de florestas renováveis. Possui alta resistência e design atual.

Congratulations! You have purchased a product of excellent quality, made from MDP or MDF wood veneer, extracted from renewable forests. It has high strength and current design.

Felicitaciones! Usted compró a un producto de excelente calidad, fabricado con placa de madera de MDP o MDF, proveniente de florestas renovables. Tiene alta resistencia y diseño actual.



ATENÇÃO
ATTENTION
ATENCIÓN

- 1)** Verifique todas as peças antes de começar a montagem.
Check all parts before starting assembly.
Verifique todas las partes antes de empezar el armado.
- 2)** Ao começar a montagem, não apoie as peças na parede.
When starting the assembly, do not support the parts on the wall.
Al empezar el armado, no apoyes las partes en la pared.
- 3)** Ao colocar as peças e ferragens de lado, cuidado para não perde-las.
When placing parts and hardware aside, be careful not to lose them.
Al poner las piezas y herrages a parte, cuidado para no dañarlas.
- 4)** O móvel deve ser montado no chão, para isso, use a própria caixa para proteger e não danificar o piso.
The furniture must be mounted on the floor, to do this, use the box itself to protect and not damage the floor.
El mueble suele ser armado al piso, para eso, use la propia caja para protegerlo y no dañar al piso.

- 5)** Comece a montagem seguindo as instruções passo a passo.
Begin assembly by following the step-by-step instructions.
Comience el armado siguiendo la instrucciones paso a paso.
- 6)** É de responsabilidade do montador seguir as intruções desse manual, que são fundamentais para a estrutura do móvel.
It's the assembler's responsibility to follow the instructions in this manual, which are fundamental to the structure of the furniture.
Es de responsabilidad del armador seguir las instrucciones de este manual, que son fundamentales para la estructura del mueble.

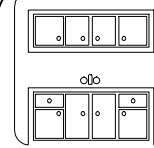

CUIDADOS
CARE
CUIDADO

- 1)** A conservação e limpeza deve ser feita com um pano levemente umedecido com água.
Care and cleaning should be done with a cloth slightly moistened with water.
La conservación y limpieza debe ser hecha con un trapo levemente humedecido en agua.
- 2)** Não use produtos abrasivos, como saponáceo, detergentes e esponja de aço.
Do not use abrasive products, such as soap, detergents and steel sponge.
No use productos abrasivos, como saponáceo, detergentes y esponja de acero.
- 3)** Não use cera ou óleo para dar brilho ao móvel.
Do not use wax or oil to shine the furniture.
No use cera o aceites para darle brillo al mueble.
- 4)** Não expor o móvel a interpéries e nem ao calor excessivo.
Do not expose the furniture to weather or excessive heat.
No exponer el mueble a interperies ni al calor excesivo.
- 5)** Ao terminar a montagem, limpe o ambiente e o móvel.
When the assembly is finished, clean the room and the furniture.
Al terminar el armado, limpie al ambiente y al mueble.

FERRAMENTAS / TOOLS / HERRAMIENTAS



MARTELO
HAMMER
MARTILLO



MARTELO DE BORRACHA
RUBBER HAMMER
MARTILLO GOMA

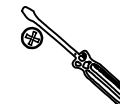

CHAVE PHILLIPS
PHILLIPS SCREWDRIVER
LLAVE PHILLIPS









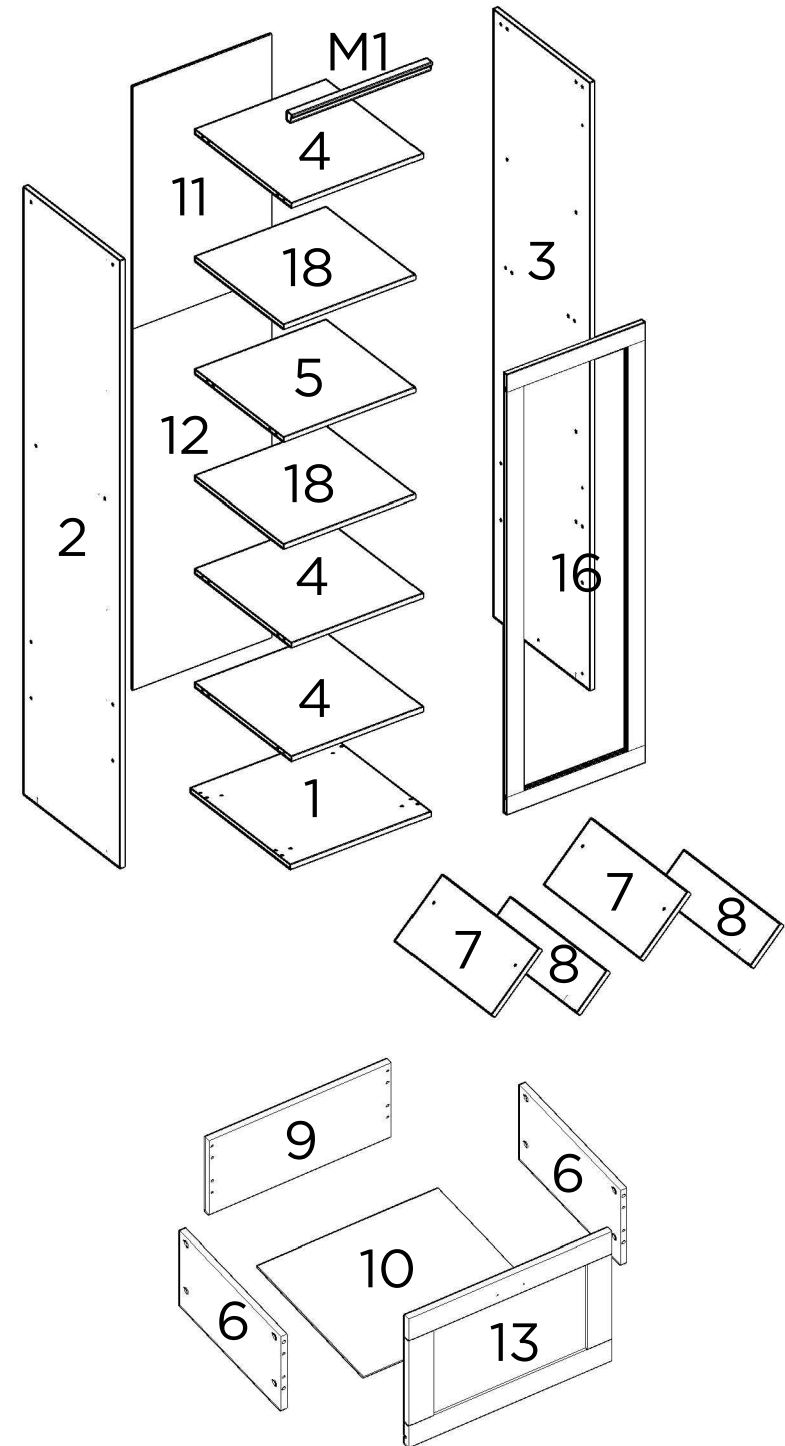



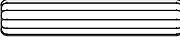





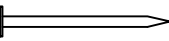

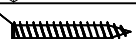

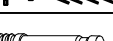

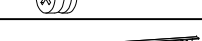

TRENA
MEASURING TAPE
CINTA MÉTRICA

PEÇAS / PARTS / PIEZAS

Nº No Num	DESCRIÇÃO DESCRIPTION DESCRIPCIÓN	QTD QTY CANT
1	BASE / BOTTOM / BASE	1
2	LATERAL ESQUERDA / LEFT SIDE PANEL / LATERAL IZQUIERDA	1
3	LATERAL DIREITA / RIGHT SIDE PANEL / LATERAL DERECHA	1
4	PRATELEIRA FIXA / FIXED PLATE PANEL / REPISA FIJA	3
5	PRATELEIRA FIXA MENOR / SMALL FIXED PLATE PANEL / REPISA MENOR FIJA	1
6	LATERAL DE GAVETA / DRAWER SIDE / LATERAL DEL CAJÓN	2
7	ADEGA MAIOR / MAJOR WINERY / BODEGA MAYOR	2
8	ADEGA MENOR / MINOR WINERY / BODEGA MENOR	2
9	COSTA DE GAVETA / DRAWER BACK / TRASERO DEL CAJÓN	1
10	FUNDO DE GAVETA / DRAWER BOTTOM PANEL / FONDO DEL CAJÓN	1
11	COSTA SUPERIOR / UPPER BACK PANEL / TRASERO SUPERIOR	1
12	COSTA INFERIOR / BOTTOM BACK PANEL / TRASERO INFERIOR	1
13	FRENTE DE GAVETA / DRAWER FRONT / FRENTE DEL CAJÓN	1
16	PORTA / DOOR / PUERTA	1
18	PRATELEIRA MÓVEL / MOBILE PLATE PANEL / REPISA MÓVIL	2
M1	MOLDURA / FRAME PANEL / MARCO	1



FERRAGENS / HARDWARE / HERRAJES

CÓD CODE COD	DESCRIÇÃO DESCRIPTION DESCRIPCIÓN	QTD QTY CANT
A	 CAVILHA / WOODEN DOWEL / TARUGO	32
B	 PARAFUSO 4X12mm / SCREW 4X12mm / TORNILLO 4X12mm	22
C	 CORREDIÇA LATERAL / SIDE SLIDE / CORREDERA LATERAL	2
D	 PARAFUSO 5X50mm / SCREW 5X50mm / TORNILLO 5X50mm	5
E	 PÉ / LEG / PATA	4
F	 PARAFUSO 3,5X40mm / SCREW 3,5X40mm / TORNILLO 3,5X40mm	20
G	 PREGO / NAIL / CLAVO	65
H	 GARRA METÁLICA / METALLIC CLAW / GRAB METALICA	2
I	 CANTONEIRA DE 2 FUROS / PLASTIC ANGLE / CANTONERA 2 AGUJEROS	4
J	 PARAFUSO 3.5X25mm / SCREW 3.5X25mm / TORNILLO 3.5X25mm	5
K	 SUPORTE DE FIXAÇÃO / MOUNTING SUPPORT / SOPORTE DE MONTAJE	1
L	 BUCHA PLÁSTICA / PLASTIC BUSHING / CASQUILLO PLÁSTICO	1
M	 PARAFUSO MINIFIX / MINIFIX SCREW / TORNILLO MINIFIX	8
N	 TAMBOR MINIFIX / MINIFIX DRUM / TAMBOR MINIFIX	8
O	 CORREDIÇA GAVETA / DRAWER SLIDE / CORREDERA DEL CAJÓN	2
P	 SUPORTE DE PRATELEIRA / SHELF SUPPORT / SOPORTE DE ESTANTES	8
Q	 CALÇO PARA DOBRADIÇA / HINGE SHED / CALZO DE BISAGRA	3
R	 DOBRADIÇA / HINGE / BIZAGRA	3
S	 PARAFUSO 3,5X25mm / SCREW 3,5X25mm / TORNILLO 3,5X25mm	4
T	 OU OR OU  PUXADOR / PULLER / TIRADOR	2
U	 TAPA-FURO MENOR / SMALL HOLE COVER / TAPA AGUJERO MINOR	16
V	 PARAFUSO 3,5X14mm / SCREW 3,5X14mm / TORNILLO 3,5X14mm	8
W	 CAPA SUPORTE / SUPPORT CAP / CAPA SOPORTE	1
X	 TAPA-FURO MAIOR / BIGGER HOLE COVER / TAPA AGUJERO MAYOR	8
Y	 PREGO ANELADO / RINGED NAIL / CLAVO ANILLADO	11

UTILIZE A RÉGUA PARA IDENTIFICAR OS PARAFUSOS
USE THE RULER TO IDENTIFY THE SCREWS
UTILICE LA REGLA PARA IDENTIFICAR LOS TORNILLOS



PESO SUPORTADO / WEIGHT SUPPORTED / PESO SOPORTADO

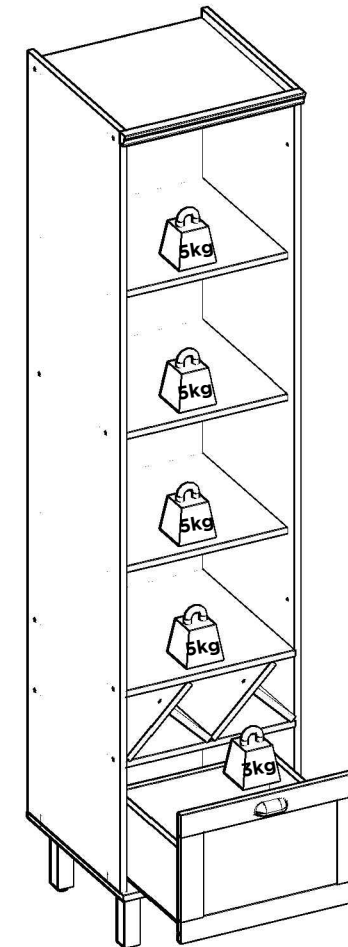

7

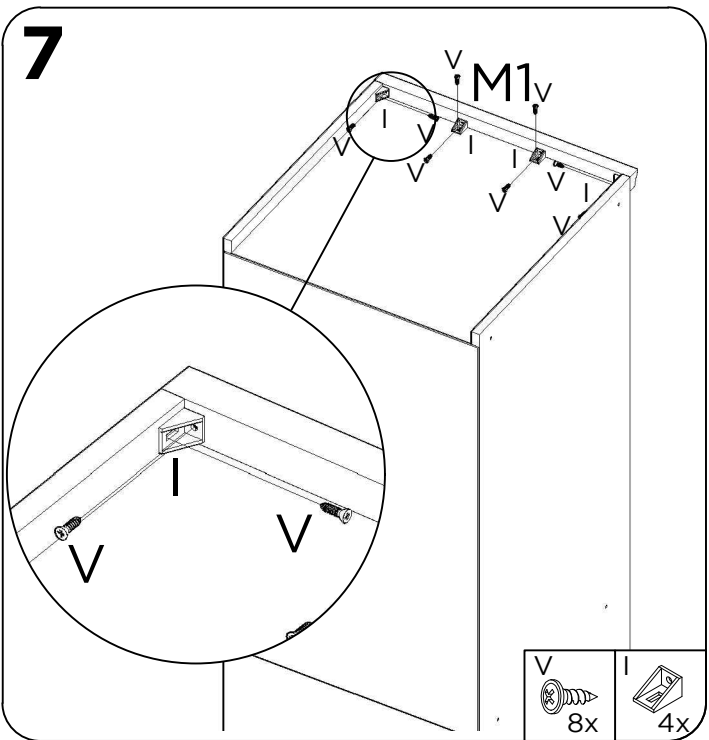

8

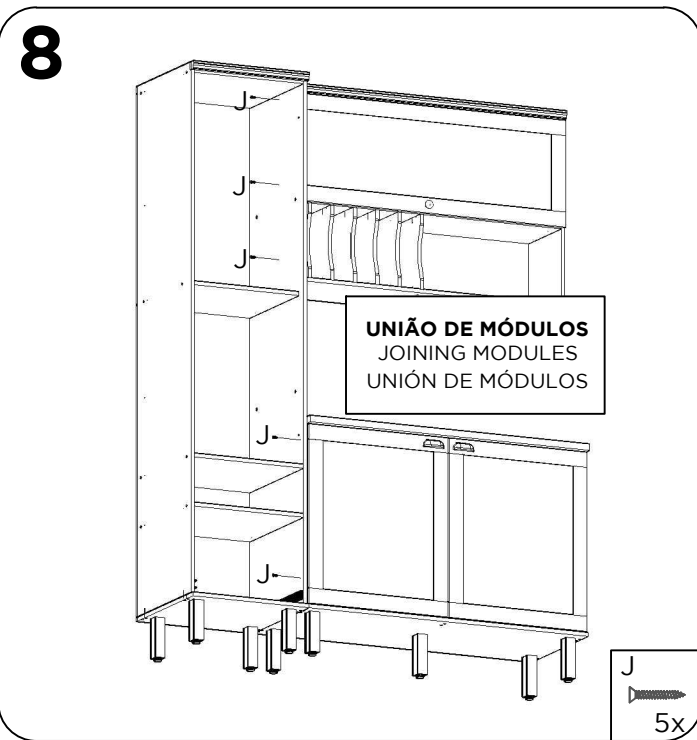

9

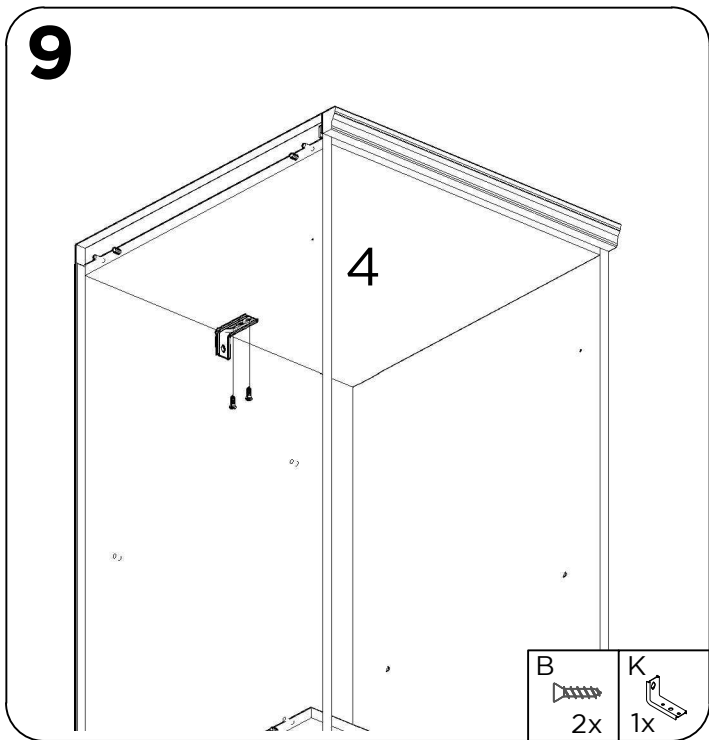

10

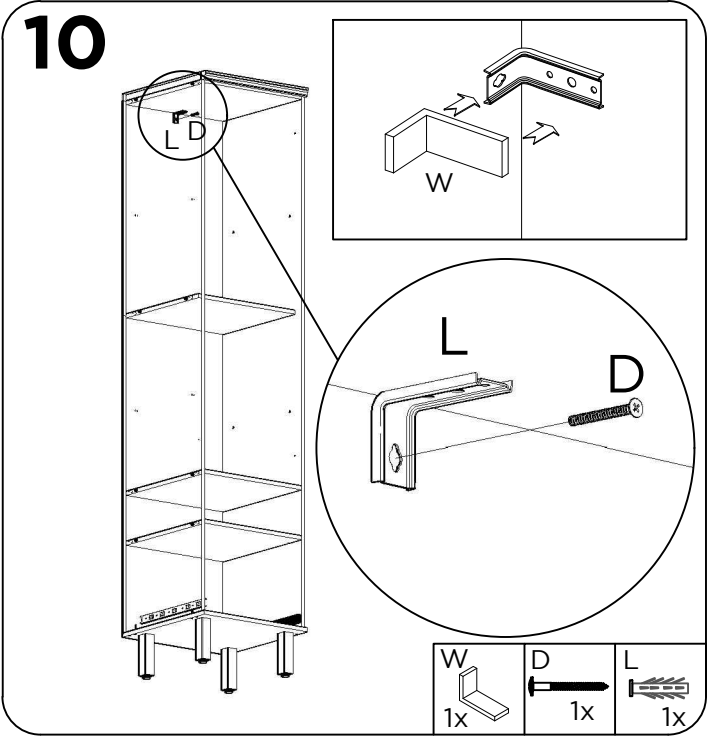

USE A BUCHA DE ACORDO COM O MATERIAL DA PAREDE
USE LA BUJE DE ACUERDO CON EL MATERIAL DE LA PARED
USE THE BUSHING ACCORDING TO THE WALL MATERIAL

MATERIAL DA PAREDE: Painel de gesso ou estuque com viga de madeira;
SISTEMA DE FIXAÇÃO: Parafuso de fixação inserido diretamente na viga de madeira.

WALL MATERIAL: Plaster or stucco panel with wooden beam;
FIXING SYSTEM: Fixing screw inserted directly into the wooden beam.

MATERIAL DE LA PARED: Panel de yeso o estuco con viga de madera;
SISTEMA DE FIJACIÓN: Tornillo de fijación insertado directamente en la viga de madera.

MATERIAL DA PAREDE: Painel de gesso sem viga de madeira;
SISTEMA DE FIXAÇÃO: Parafuso de fixação com bucha plástica.

WALL MATERIAL: Plaster panel without wooden beam;
FIXING SYSTEM: Fixing screw with plastic bushing.

MATERIAL DE LA PARED: Panel de yeso sin viga de madera;
SISTEMA DE FIJACIÓN: Tornillo de fijación con buje de plástico.

MATERIAL DA PAREDE: Alvenaria (concreto ou tijolo);
SISTEMA DE FIXAÇÃO: Parafuso de fixação com bucha.

WALL MATERIAL: Masonry (concrete or brick);
FIXING SYSTEM: Fixing screw with plastic bushing.

MATERIAL DE LA PARED: Albañilería (hormigón o ladrillo);
SISTEMA DE FIJACIÓN: Tornillo de fijación con buje de plástico.

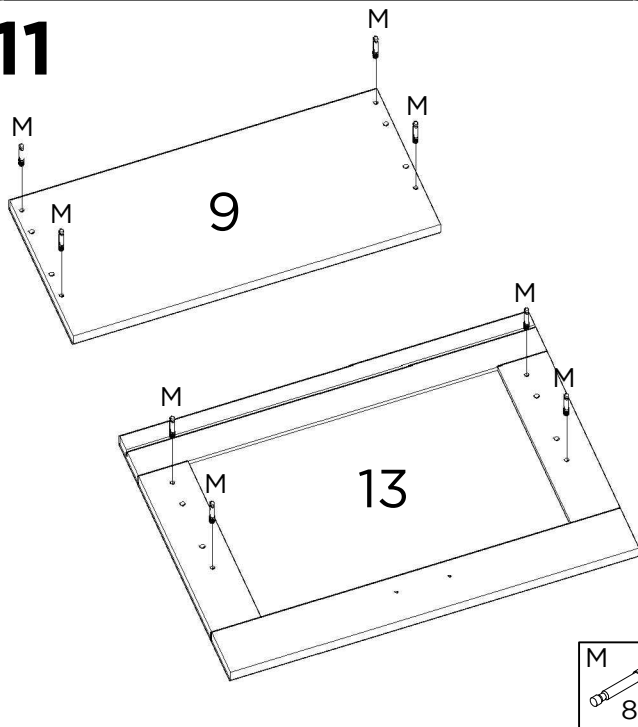
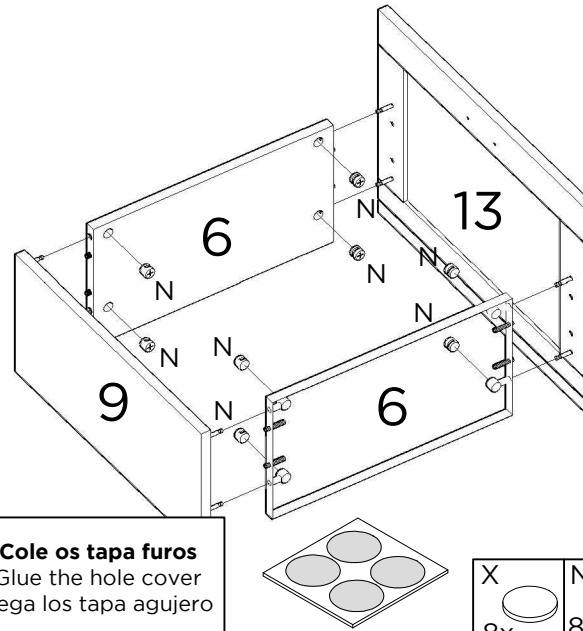
11**12**

Cole os tapa furos
 Glue the hole cover
 Pega los tapa agujero

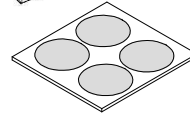
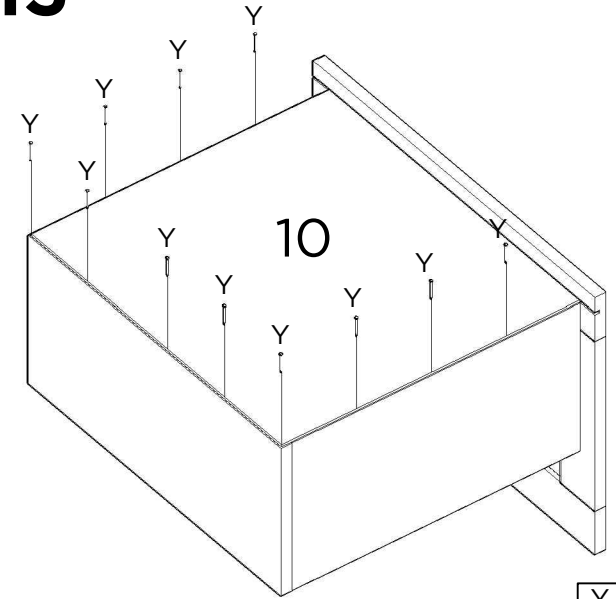
**13****14**

**SIGA AS INSTRUÇÕES NA PÁGINA DA
 CORREDIÇA.**
 FOLLOW THE INSTRUCTIONS ON THE
 SLIDE PAGE.
 SIGA LAS INSTRUCCIONES EN LA PÁGINA
 DE LA CORREDERA.

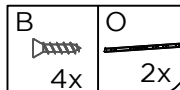
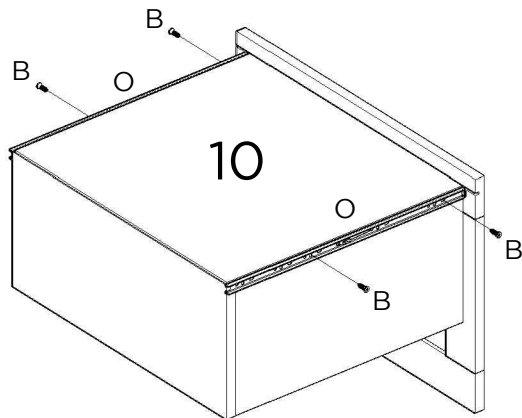
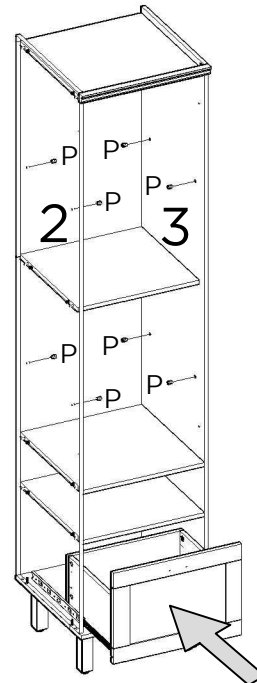
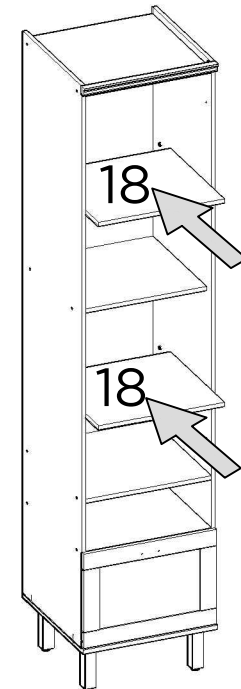
**15****16**

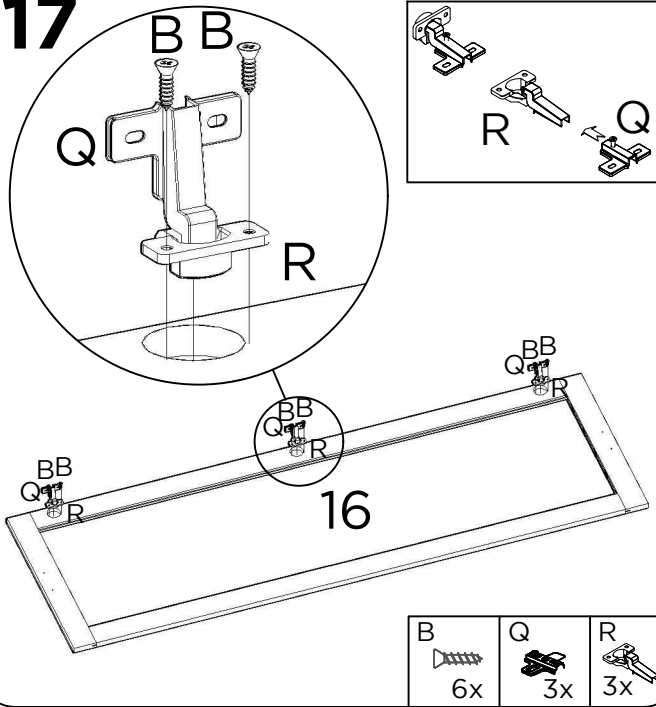
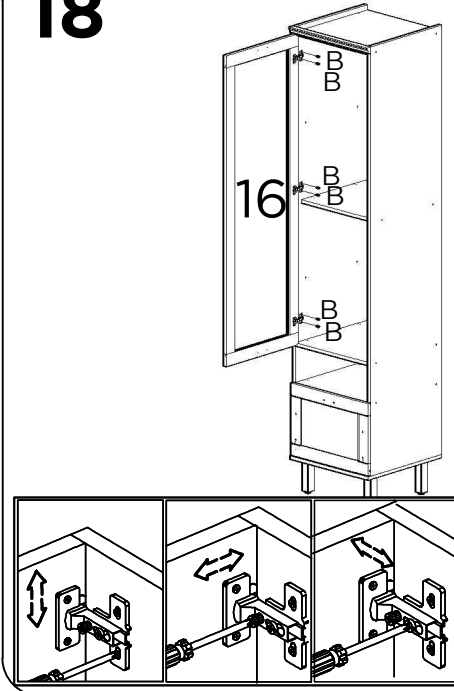
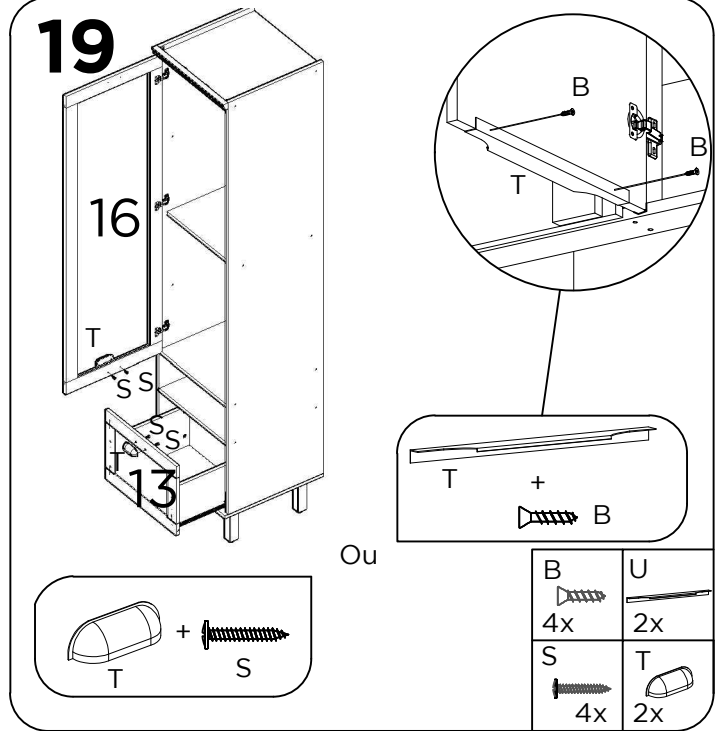
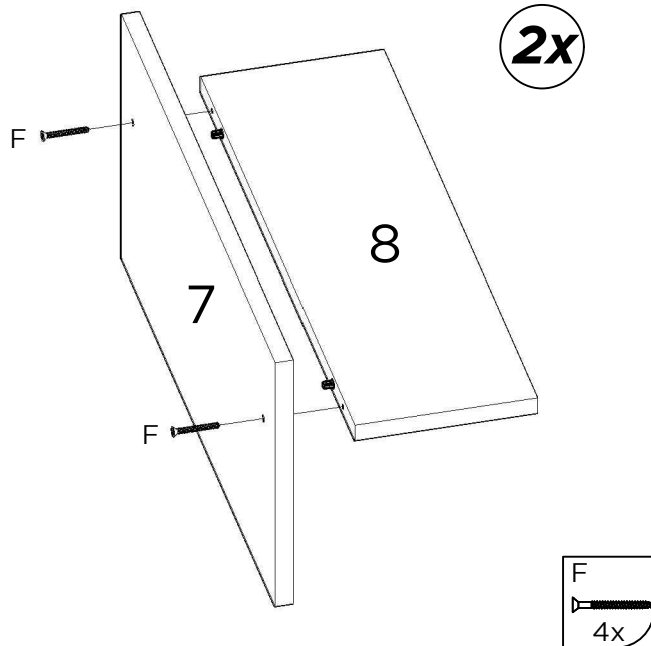
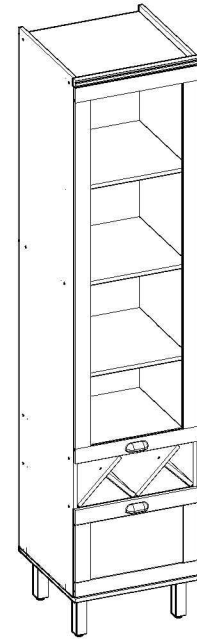
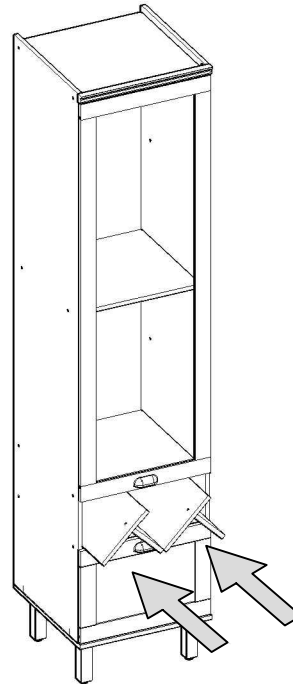
17**18****19****20****21**

Para instalar as corrediças telescópicas é necessário seguir os passos, separando as partes que compõem a corrediça.

To install the telescopic slides, it is necessary to follow the steps, separating the parts that make up the slide.

Para instalar las correderas telescópicas es necesario seguir los pasos, separando las dos partes que componen la pieza.

Corrediça telescópica / Telescopic slides Corredera telescópica



Passo 1 / Step 1 / Paso 1

Corrediça telescópica aberta / Telescopic slide open / Corredera telescópica abierta



Para separar as partes da corrediça, puxe o engate que está na parte traseira da corrediça (desenho ao lado) no sentido anti-horário, separando as duas partes, para facilitar a fixação no móvel.

To separate the parts of the slide, pull the hook on the back of the slide (illustration on the side) counterclockwise, separating the two parts, to facilitate attachment to the furniture.

Para separar las dos partes de la corredera, tire el engate que está en la parte de atrás de la corredera (dibujo al lado) en el sentido anti-horario, separando las dos partes, para facilitar la fijación en el mueble.

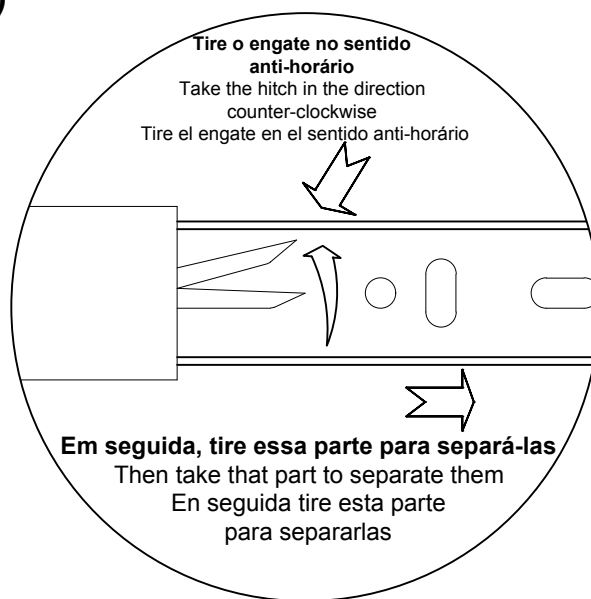
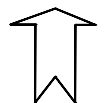
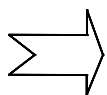

Passo 2 / Step 2 / Paso 2

Com as partes da corrediça separadas, fixar-las no móvel.

With the slide parts separated, fix them to the furniture.

Con las partes de la corredera separadas, fijarlas en el mueble.

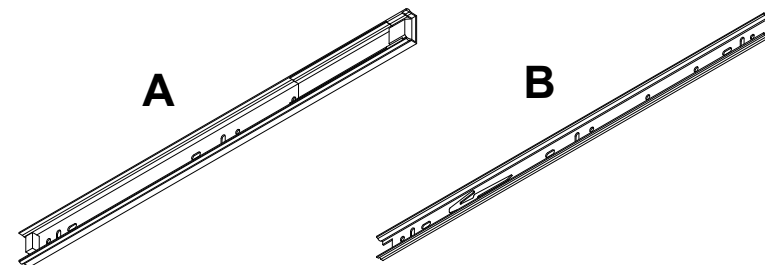

As corrediças devem ficar alinhadas com a parte inferior das laterais de gavetas.

The slide should be flush with the underside of the drawer sides.

Las correderas deben quedar aliñada con la parte inferior de las laterales de los cajones.

