

MANUAL DE MONTAGEM / ASSEMBLY INSTRUCTIONS / PLANO DE ARMADO

Antes de montar o móvel, leia com atenção o manual de montagem!
Before assembling the furniture, carefully read the assembly instructions!
Antes de armar el mueble, lea con atención el manual de ensamble!

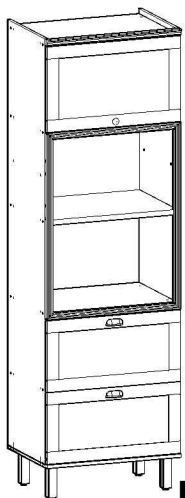

Ref.: 1514

genialflex
ambientes incríveis para todos

Parabéns! Você comprou um produto de excelente qualidade, fabricado com chapa de madeira de MDP ou MDF, extraída de florestas renováveis. Possui alta resistência e design atual.

Congratulations! You have purchased a product of excellent quality, made from MDP or MDF wood veneer, extracted from renewable forests. It has high strength and current design.

Felicitaciones! Usted compró a un producto de excelente calidad, fabricado con placa de madera de MDP o MDF, proveniente de florestas renovables. Tiene alta resistencia y diseño actual.



ATENÇÃO
ATTENTION
ATENCIÓN

- 1) Verifique todas as peças antes de começar a montagem.**
Check all parts before starting assembly.
Verifique todas las partes antes de empezar el armado.
- 2) Ao começar a montagem, não apoie as peças na parede.**
When starting the assembly, do not support the parts on the wall.
Al empezar el armado, no apoyes las partes en la pared.
- 3) Ao colocar as peças e ferragens de lado, cuidado para não perde-las.**
When placing parts and hardware aside, be careful not to lose them.
Al poner las piezas y herrages a parte, cuidado para no dañarlas.
- 4) O móvel deve ser montado no chão, para isso, use a própria caixa para proteger e não danificar o piso.**
The furniture must be mounted on the floor, to do this, use the box itself to protect and not damage the floor.
El mueble suele ser armado al piso, para eso, use la propia caja para protegerlo y no dañar al piso.

- 5) Comece a montagem seguindo as instruções passo a passo.**
Begin assembly by following the step-by-step instructions.
Comience el armado siguiendo la instrucciones paso a paso.
- 6) É de responsabilidade do montador seguir as intruções desse manual, que são fundamentais para a estrutura do móvel.**
It's the assembler's responsibility to follow the instructions in this manual, which are fundamental to the structure of the furniture.
Es de responsabilidad del armador seguir las instrucciones de este manual, que son fundamentales para la estructura del mueble.

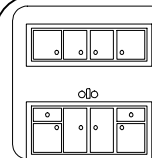

CUIDADOS
CARE
CUIDADO

- 1) A conservação e limpeza deve ser feita com um pano levemente umedecido com água.**
Care and cleaning should be done with a cloth slightly moistened with water.
La conservación y limpieza debe ser hecha con un trapo levemente humedecido en agua.
- 2) Não use produtos abrasivos, como saponáceo, detergentes e esponja de aço.**
Do not use abrasive products, such as soap, detergents and steel sponge.
No use productos abrasivos, como saponáceo, detergentes y esponja de acero.
- 3) Não use cera ou óleo para dar brilho ao móvel.**
Do not use wax or oil to shine the furniture.
No use cera o aceites para darle brillo al mueble.
- 4) Não expor o móvel a interpéries e nem ao calor excessivo.**
Do not expose the furniture to weather or excessive heat.
No exponer el mueble a interperies ni al calor excesivo.
- 5) Ao terminar a montagem, limpe o ambiente e o móvel.**
When the assembly is finished, clean the room and the furniture.
Al terminar el armado, limpie al ambiente y al mueble.

FERRAMENTAS / TOOLS / HERRAMIENTAS



MARTELO
HAMMER
MARTILLO



MARTELO DE BORRACHA
RUBBER HAMMER
MARTILLO GOMA

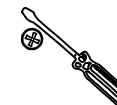

CHAVE PHILLIPS
PHILLIPS SCREWDRIVER
LLAVE PHILLIPS









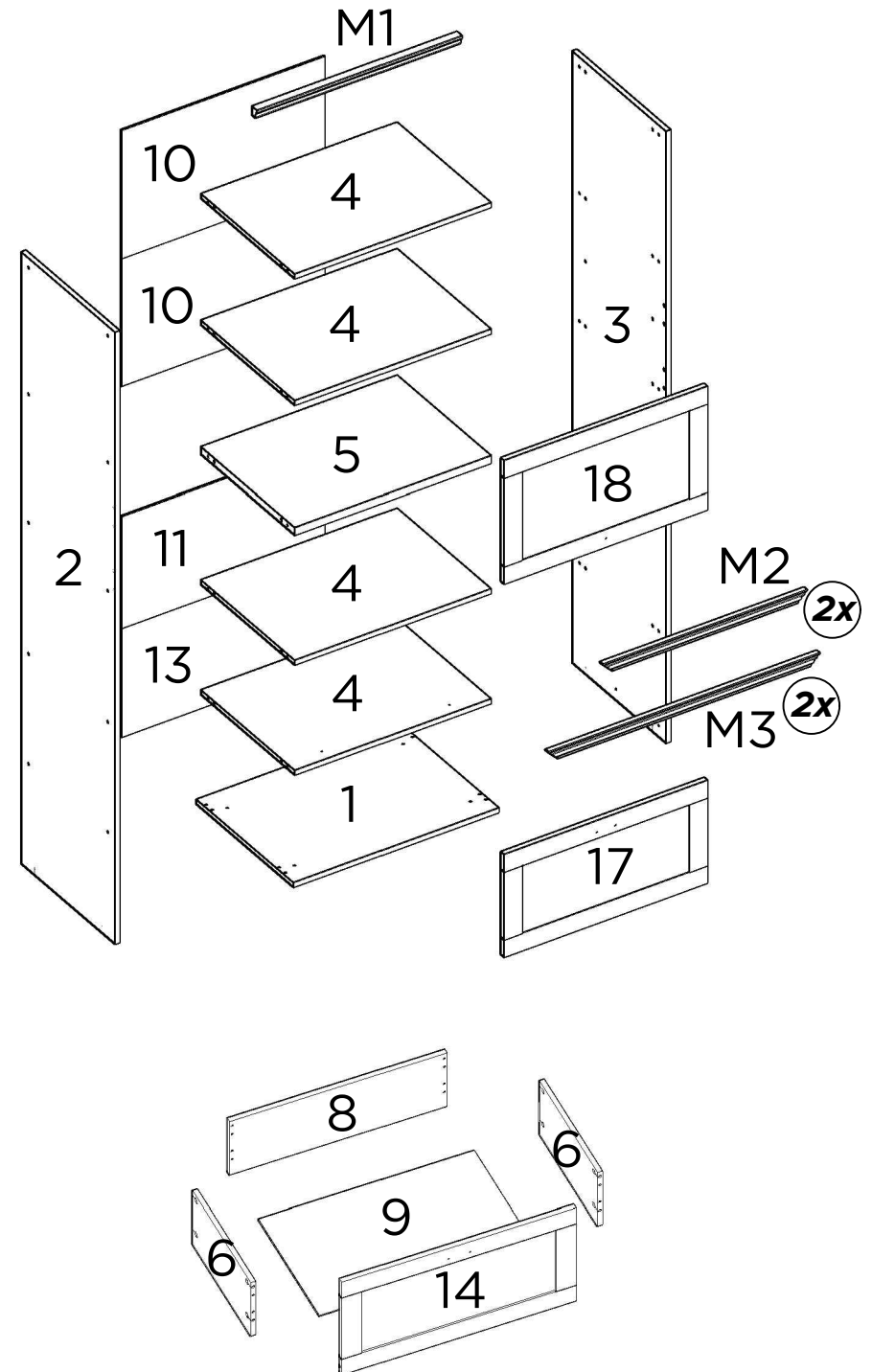



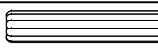





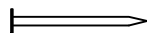





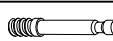



TRENA
MEASURING TAPE
CINTA MÉTRICA

PEÇAS / PARTS / PIEZAS

Nº No Num	DESCRIÇÃO DESCRIPTION DESCRIPCIÓN	QTD QTY CANT
1	BASE BOTTOM BASE	1
2	LATERAL ESQUERDA LEFT SIDE PANEL LATERAL IZQUIERDA	1
3	LATERAL DIREITA RIGHT SIDE PANEL LATERAL DERECHA	1
4	PRATELEIRA / TAMPO PLATE PANEL / TOP REPISA / TABLERO	4
5	PRATELEIRA CENTRAL MIDDLE PLATE PANEL REPISA CENTRAL	1
6	LATERAL DE GAVETA DRAWER SIDE LATERAL DEL CAJÓN	2
8	COSTA DE GAVETA DRAWER BACK TRASERO DEL CAJÓN	1
9	FUNDO DE GAVETA DRAWER BOTTOM PANEL FONDO DEL CAJÓN	1
10	COSTA SUPERIOR UPPER BACK PANEL TRASERO SUPERIOR	2
11	COSTA CENTRAL MIDDLE BACK PANEL TRASERO CENTRAL	1
13	COSTA INFERIOR BOTTOM BACK PANEL TRASERO INFERIOR	1
14	FRENTE DE GAVETA DRAWER FRONT FRENTE DEL CAJÓN	1
17	PORTA INFERIOR BOTTOM DOOR PUERTA INFERIOR	1
18	PORTA SUPERIOR UPPER DOOR PUERTA SUPERIOR	1
M1	MOLDURA SUPERIOR UPPER FRAME PANEL MARCO SUPERIOR	1
M2	MOLDURA MENOR MINOR FRAME MARCO MENOR	2
M3	MOLDURA MAIOR MAJOR FRAME MARCO MAYOR	2



FERRAGENS / HARDWARE / HERRAJES

CÓD CODE COD	DESCRIÇÃO DESCRIPTION DESCRIPCIÓN	QTD QTY CANT
A	 CAVILHA WOODEN DOWEL TARUGO	40
B	 PARAFUSO 4X14mm SCREW 4X14mm TORNILLO 4X14mm	32
C	 CORREDEÇA LATERAL SIDE SLIDE CORREDERA LATERAL	2
D	 PARAFUSO 3,5X40mm SCREW 3,5X40mm TORNILLO 3,5X40mm	24
E	 PARAFUSO 5X50mm SCREW 5X50mm TORNILLO 5X50mm	5
F	 PÉ LEG PATA	4
G	 PREGO NAIL CLAVO	69
H	 GARRA METÁLICA METALLIC CLAW GRAB METALICA	8
I	 CANTONEIRA DE 2 FUROS PLASTIC ANGLE CANTONERA 2 AGUJEROS	16
J	 PARAFUSO 3,5X14mm SCREW 3,5X14mm TORNILLO 3,5X14mm	32
K	 PARAFUSO 3,5X25mm SCREW 3,5X25mm TORNILLO 3,5X25mm	5
L	 SUPORTE DE FIXAÇÃO MOUNTING SUPPORT SOPORTE DE MONTAJE	1
M	 BUCHA PLÁSTICA PLASTIC BUSHING CASQUILLO PLÁSTICO	1
N	 PARAFUSO MINIFIX MINIFIX SCREW TORNILLO MINIFIX	8
O	 TAMBOR MINIFIX MINIFIX DRUM TAMBOR MINIFIX	8
P	 DOBRADIÇA HINGE BIZAGRA	4
Q	 CALÇO PARA DOBRADIÇA HINGE SHED CALZO DE BISAGRA	4
R	 PISTÃO PISTON PISTÓN	2
S	 PARAFUSO 3,5X25mm SCREW 3,5X25mm TORNILLO 3,5X25mm	5
T	 PUXADOR PULLER TIRADOR	1
U	 PUXADOR PULLER TIRADOR	2
V	 CORREDEÇA GAVETA DRAWER SLIDE CORREDERA DEL CAJÓN	2
W	 TAPA-FURO MENOR SMALL HOLE COVER TAPA AGUJERO MINOR	20
X	 TAPA-FURO MAIOR BIGGER HOLE COVER TAPA AGUJERO MAYOR	8
Y	 CAPA SUPORTE SUPPORT CAP CAPA SOPORTE	1
Z	 PREGO ANELADO RINGED NAIL CLAVO ANILLADO	13
a1	 TAPA-FURO COM RANHURA HOLE COVER TAPA AGUJERO	4

UTILIZE A RÉGUA PARA IDENTIFICAR OS PARAFUSOS
USE THE RULER TO IDENTIFY THE SCREWS
UTILICE LA REGLA PARA IDENTIFICAR LOS TORNILLOS

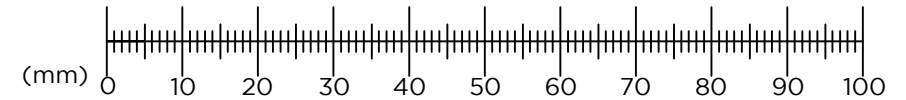

PESO SUPORTADO / WEIGHT SUPPORTED / PESO SOPORTADO

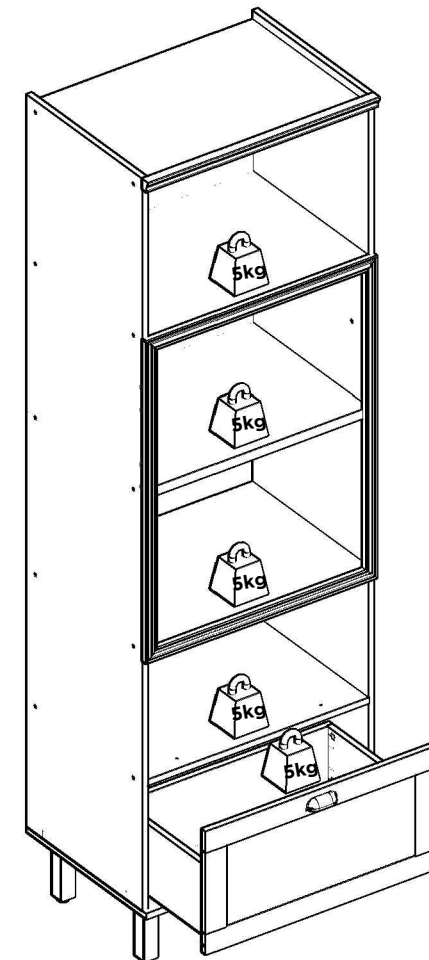

12

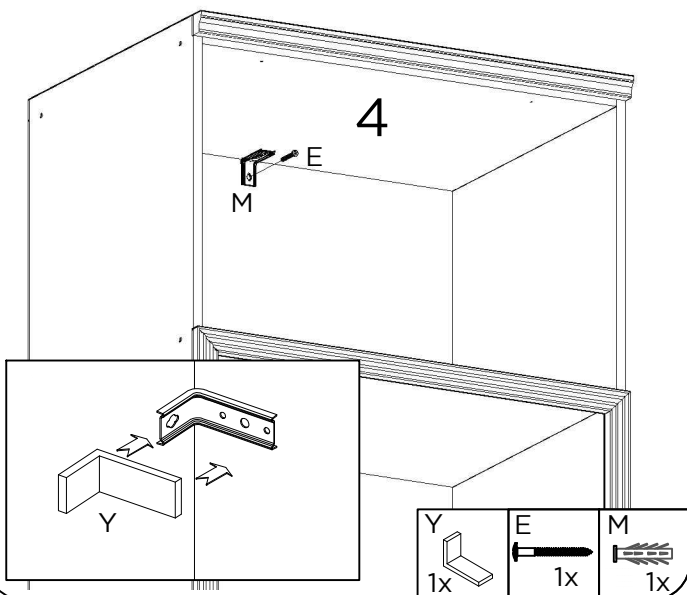

MATERIAL DA PAREDE: Painel de gesso ou estuque com viga de madeira;
SISTEMA DE FIXAÇÃO: Parafuso de fixação inserido diretamente na viga de madeira.

WALL MATERIAL: Plaster or stucco panel with wooden beam;
FIXING SYSTEM: Fixing screw inserted directly into the wooden beam.

MATERIAL DE LA PARED: Panel de yeso o estuco con viga de madera;
SISTEMA DE FIJACIÓN: Tornillo de fijación insertado directamente en la viga de madera.

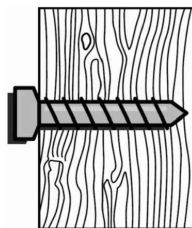

USE A BUCHA DE ACORDO COM O MATERIAL DA PAREDE
USE LA BUJE DE ACUERDO CON EL MATERIAL DE LA PARED
USE THE BUSHING ACCORDING TO THE WALL MATERIAL

MATERIAL DA PAREDE: Painel de gesso sem viga de madeira;
SISTEMA DE FIXAÇÃO: Parafuso de fixação com bucha plástica.

WALL MATERIAL: Plaster panel without wooden beam;
FIXING SYSTEM: Fixing screw with plastic bushing.

MATERIAL DE LA PARED: Panel de yeso sin viga de madera;
SISTEMA DE FIJACIÓN: Tornillo de fijación con buje de plástico.

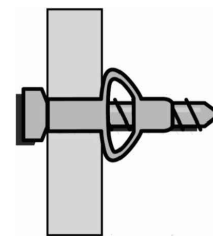

MATERIAL DA PAREDE: Alvenaria (concreto ou tijolo);
SISTEMA DE FIXAÇÃO: Parafuso de fixação com bucha.

WALL MATERIAL: Masonry (concrete or brick);
FIXING SYSTEM: Fixing screw with plastic bushing.

MATERIAL DE LA PARED: Albañilería (hormigón o ladrillo);
SISTEMA DE FIJACIÓN: Tornillo de fijación con buje de plástico.

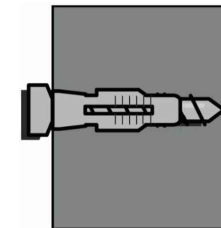

13

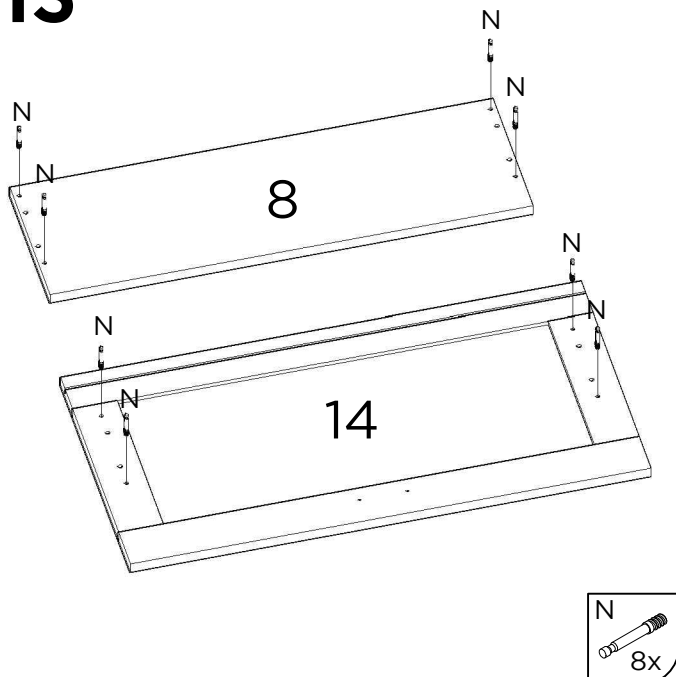

14

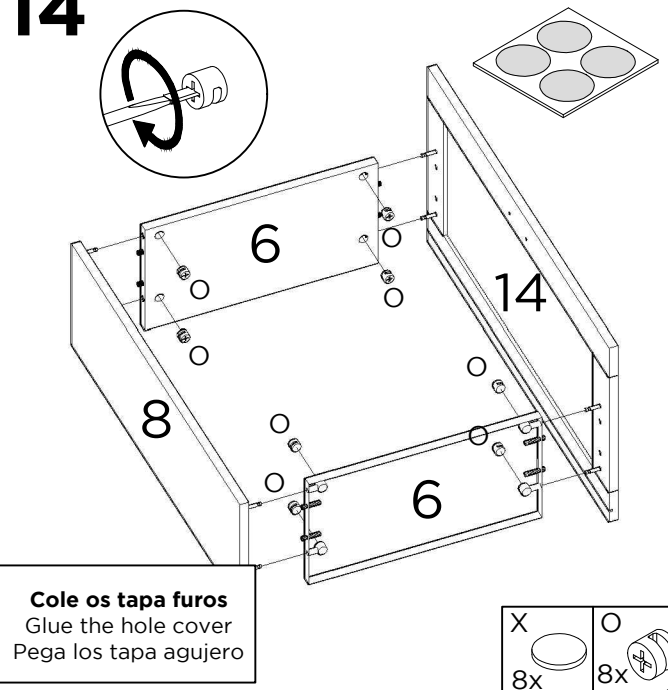

Cole os tapa furos
Glue the hole cover
Pega los tapa agujero

15

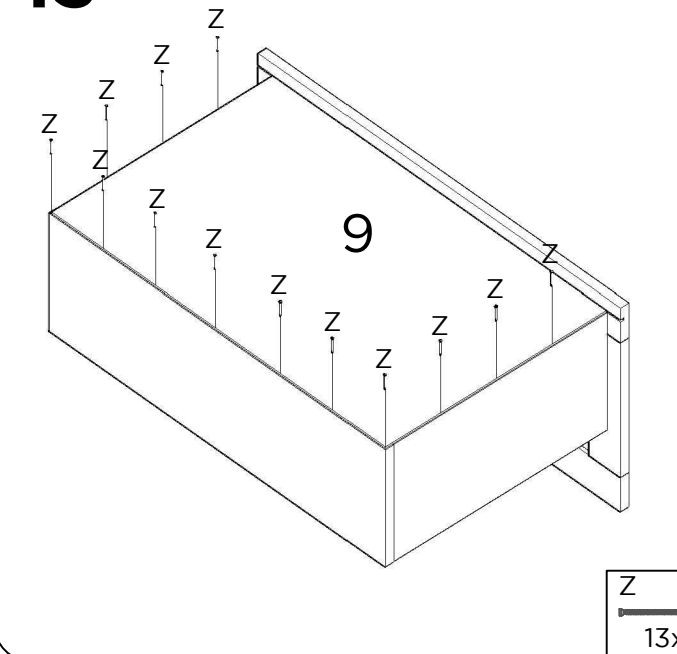

16

SIGA AS INSTRUÇÕES NA PÁGINA DA CORREDIÇA.
FOLLOW THE INSTRUCTIONS ON THE SLIDE PAGE.
SIGA LAS INSTRUCCIONES EN LA PÁGINA DE LA CORREDERA.

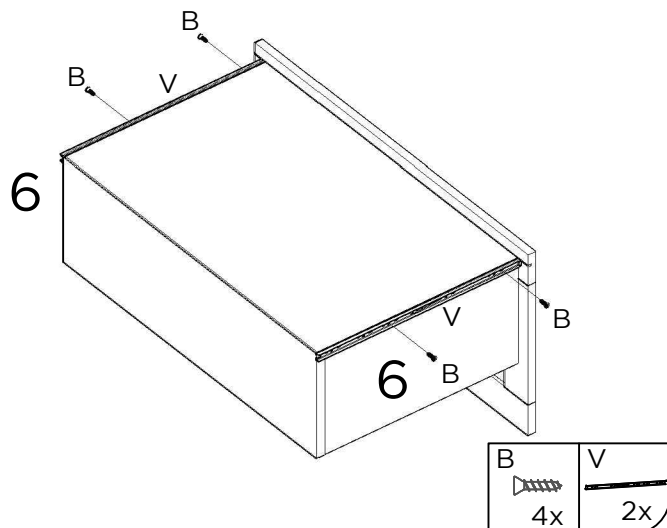

17

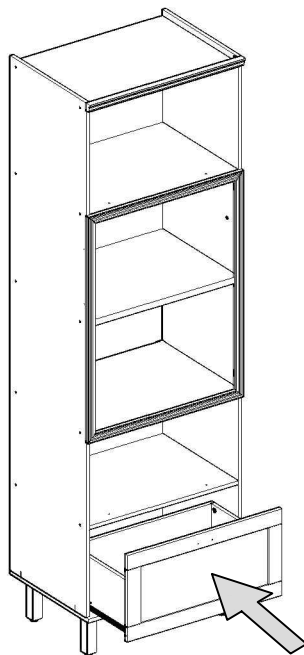

18

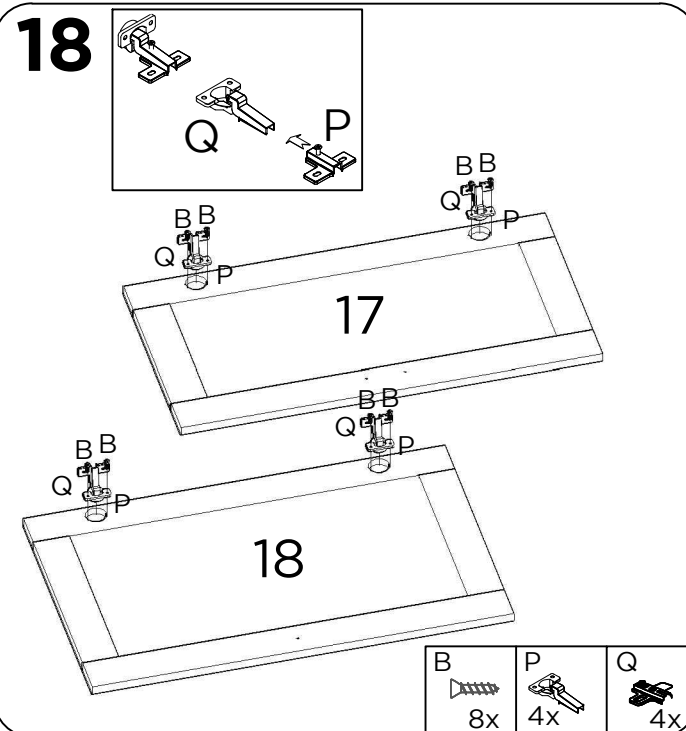

19

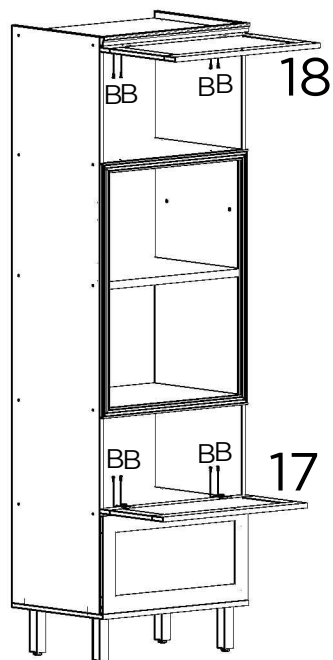

PARA EFETUAR A INSTALAÇÃO DO PISTÃO, SIGA OS PASSOS NO MANUAL QUE O ACOMPANHA.
TO INSTALL THE PISTON, FOLLOW THE STEPS IN THE ACCOMPANYING MANUAL.
PARA INSTALAR EL PISTÓN SEGUIR LOS PASOS DEL MANUAL ADJUNTO.

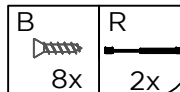
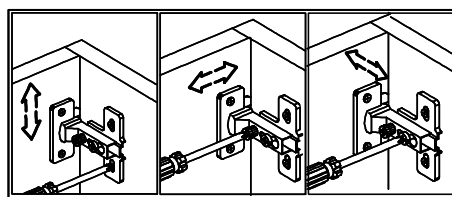

20

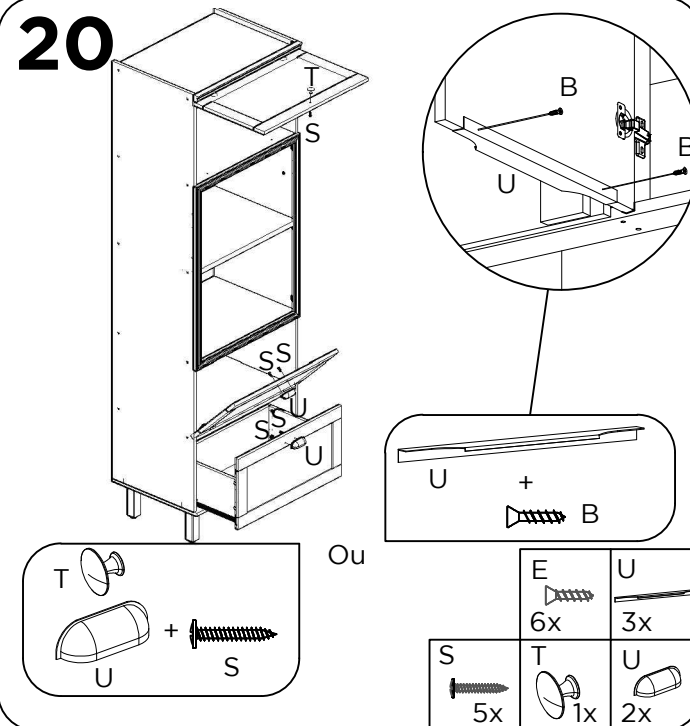

Para instalar as corrediças telescópicas é necessário seguir os passos, separando as partes que compõem a corrediça.

To install the telescopic slides, it is necessary to follow the steps, separating the parts that make up the slide.

Para instalar las correderas telescópicas es necesario seguir los pasos, separando las dos partes que componen la pieza.

Corrediça telescópica / Telescopic slides Corredera telescópica



Passo 1 / Step 1 / Paso 1

Corrediça telescópica aberta / Telescopic slide open / Corredera telescópica abierta



Para separar as partes da corrediça, puxe o engate que está na parte traseira da corrediça (desenho ao lado) no sentido anti-horário, separando as duas partes, para facilitar a fixação no móvel.

To separate the parts of the slide, pull the hook on the back of the slide (illustration on the side) counterclockwise, separating the two parts, to facilitate attachment to the furniture.

Para separar las dos partes de la corredera, tire el engate que está en la parte de atrás de la corredera (dibujo al lado) en el sentido anti-horario, separando las dos partes, para facilitar la fijación en el mueble.

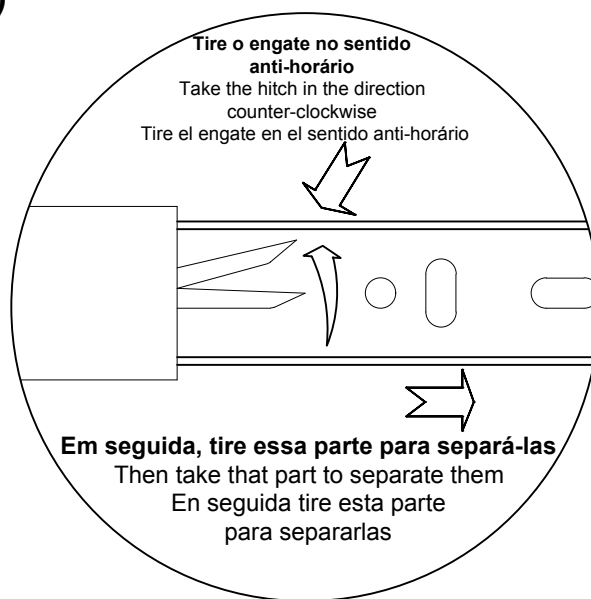
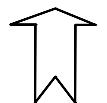
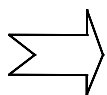

Passo 2 / Step 2 / Paso 2

Com as partes da corrediça separadas, fixar-las no móvel.

With the slide parts separated, fix them to the furniture.

Con las partes de la corredera separadas, fijarlas en el mueble.

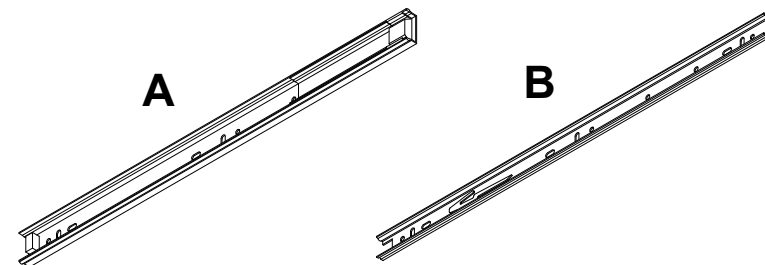

As corrediças devem ficar alinhadas com a parte inferior das laterais de gavetas.

The slide should be flush with the underside of the drawer sides.

Las correderas deben quedar aliñada con la parte inferior de las laterales de los cajones.

