

Nº	Cód.	Peças	Piezas	Parts	Medida / Size	Qtd.	Vol.
01	07589	Base	Base	Base	2700x595x15	01	03
02	07590	Lateral esquerda	Lateral izquierda	Left side	2340x595x15	01	04
03	07592	Divisória esquerda	División izquierda	Left division	2244x576x15	01	05
04	07593	Divisória direita	División derecha	Right division	2244x576x15	01	05
05	07591	Lateral direita	Lateral derecha	Right side	2340x595x15	01	04
06	06723	Tampo	Cubierta	Top	2700x576x15	01	03
07	07594	Divisória central	División central	Central division	1820x535x15	01	05
08	07595	Prateleira menor	Estante menor	Smaller shelf	530x438x15	03	04
09	07596	Prateleira do calceiro	Estante del pantalón	Trouser shelf	438x330x15	01	05
10	07597	Prateleira superior	Estante superior	Upper shelf	890x576x15	02	06
11	07598	Prateleira central	Estante central	Central shelf	890x576x15	01	04
12	07599	Prateleira da gaveta	Estante del cajone	Drawer off shelf	890x535x15	02	06
13	07600	Frente de gaveta	Frente del cajone	Front off drawer	830x185x15	06	06
14	06197	Lateral de gaveta	Lateral del cajone	Side panel of the drawer	400x155x15	12	06
15	07601	Contra fundo	Trasero del cajone	Rear panel of the drawer	785x100x15	06	06
16	07602	Rodapé frontal	Rodapie frontal	Lower front crossbar	2700x66x15	01	03
17	06733	Rodapé traseiro	Rodapie trasero	Lower rear crossbar	2700x66x15	01	03
18	07603	Trava do rodapé	Traba del rodapie	Smaller crossbar	555x66x15	04	03
19	07604	Porta menor	Puerta menor	Smaller door	2190x448x15	04	01
20	07605	Porta maior	Puerta mayor	Larger door	2288x448x15	02	02
21	07606	Moldura do led	Cubierta led	Led of frame	2730x80x15	01	03
22	07607	Moldura frontal	Cubierta frontal	Front frame	903x100x15	02	03
23	07608	Distanciador maior	Espaciador mayor	Larger spacer	648x63x25	04	03
24	07609	Distanciador menor	Espaciador menor	Smaller spacer	648x28x25	04	03
25	07610	Fundo de gaveta	Fondo del cajone	Bottom of the drawer	798x405x2,5	06	03
26	07611	Fundo traseiro furado	Fondo trasero perforado	Drilled rear	903x551x2,5	01	02
27	07612	Fundo traseiro	Fondo trasero	Rear	903x551x2,5	11	02
28	07161	Perfil H	Perfil	Profile	2698x40x6	03	03
29	30018343	Espelho	Espejo	Mirror	1095x365	04	08

Recorte aqui e guarde seu certificado de garantia!

Certificado de garantia

A Gelius Indústria de Móveis confia na qualidade de seus produtos e por isso o garante pelo prazo de 90 dias para defeitos de fabricação em condições normais de uso.

Resultarão nula a garantia e sem efeito a cobertura, se o produto, (incluindo vidros e ou espelhos que o compõe):

- sofrer dano provocado por acidente, agente da natureza.
- uso indevido ou maus tratos como arrastar, subir em cima, colocar produtos com excesso de peso).
- não utilizado para os fins a que se destina.
- conter manchas provocadas por uso de produtos químicos em sua limpeza.
- excesso de umidade ou água.

Ao detectar qualquer defeito em seu móvel, entre em contato com a loja onde foi efetuada a compra. A comprovação de que o móvel a ser consertado ou substituído encontra-se dentro do prazo de garantia é de total responsabilidade do fabricante e deve ser feita mediante a apresentação desse certificado corretamente preenchido e sem rasuras ou resalvas.

Cuidados com seu móvel Gelius!

- para limpeza do seu móvel, utilize apenas pano macio e seco.
- jamais limpe-o com palha de aço, álcool ou qualquer outro produto químico ou abrasivos, óleos de peroba ou produtos do gênero.
- evite deixá-lo sob raios solares ou chuva.
- ao transportar o seu móvel Gelius, prenda-o firmemente para que não ocorra quedas indesejáveis.

Seguindo corretamente as informações acima, você conservará por muito mais tempo o seu móvel Gelius!

GARANTIA DO CLIENTE:

Cliente: _____

Rua: _____ Nº: _____ Bairro: _____

Cidade: _____ UF: _____ Loja onde comprou: _____

Data da compra: ____/____/____ Nota Fiscal: _____

Data da reclamação na loja: ____/____/____

Defeito constante: _____

Recomendações | Recomendaciones | Recommendations

Atenção
Atención
Attention

Este produto deve ser montado por um profissional.

Este producto debe ser ensamblado por un profesional.

This product must be assembled by a professional.

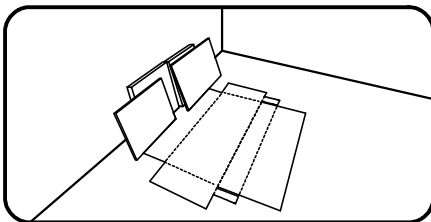

Antes de começar a montagem prepare o ambiente, deixando-o completamente limpo e com bom espaço para iniciar o trabalho. Utilize o papelão da própria embalagem para separar e apoiar as peças retiradas da caixa.

Antes de comenzar el montaje preparar el ambiente, dejándolo completamente limpio y con buen espacio para comenzar el trabajo. Utilice el cartón de la embalaje para separar y apoyar las piezas desmontadas de las cajas.

Prepare the room before starting the assembly, leaving it completely clean and the area in good condition to start the work. Use the cardboard of the packaging to separate and support the parts removed from the boxes.

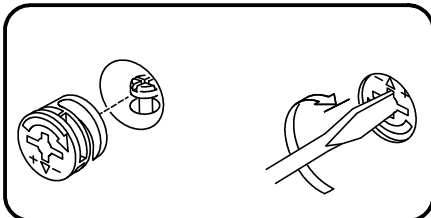

Como usar o acessório Pino e Tambor Minifix (quando utilizado no produto).

Como usar el herraje Pino y Tambor Minifix (cuando se usa en el producto).

How to use the Minifix Set (when used in the product).

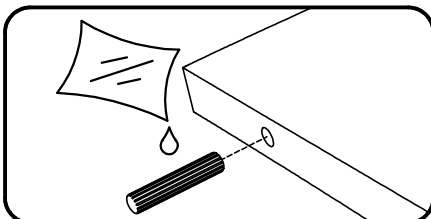

Aplicar cola nas cavilhas de madeira (quando utilizado no produto).

Aplicar pegamento a las clavijas de madera (cuando se usa en el producto).

Apply glues to the wooden dowels (when used in the product).

Ferramentas recomendadas para montagem | Herramientas de montaje recomendadas | Recommended tools

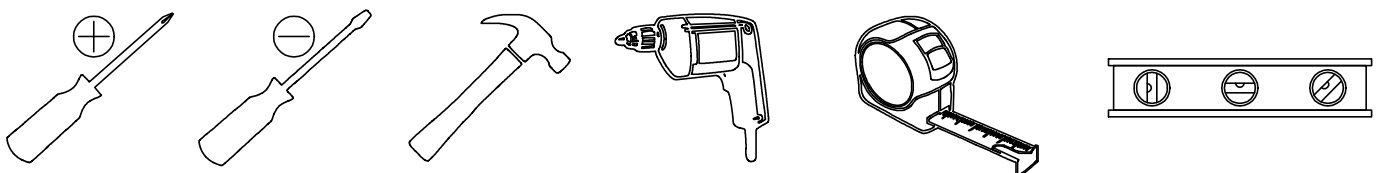

Acessórios e ferragens | Herrajes | Hardware

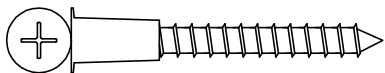

- A) cód. 30008477 (Preto) 044 un.
 cód. 30017779 (Bicro) 044 un.



- B) cód. 30000711 (Preto) 258 un.
 cód. 30014538 (Bicro) 258 un.



- C) cód. 30000730 (Preto) 138 un.
 cód. 30014537 (Bicro) 138 un.

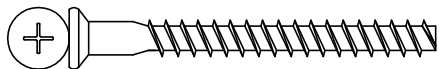

- D) cód. 30010784 (Preto) 004 un.
 cód. 30010093 (Bicro) 004 un.

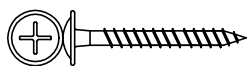

- E) cód. 30000843 (Preto) 008 un.
 cód. 30012342 (Bicro) 008 un.

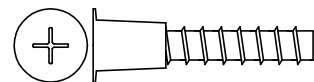

- F) cód. 30000674 (Preto) 016 un.
 cód. 30018169 (Bicro) 016 un.

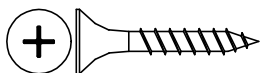

- G) cód. 30010241 004 un.

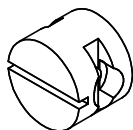

- H) cód. 30008479 008 un.

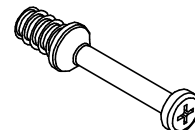

- I) cód. 30006753 036 un.

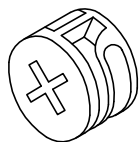

- J) cód. 30001073 036 un.

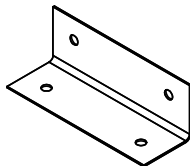

- K) cód. 30003829 018 un.

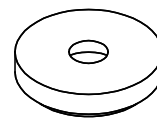

- L) cód. 30000853 008 un.

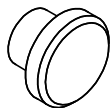

- M) cód. 30018320 004 un.

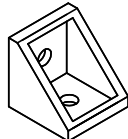

- N) cód. 30015224 024 un.



- O) cód. * 010 un.

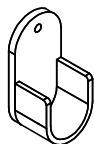

- P) cód. 30001188 008 un.

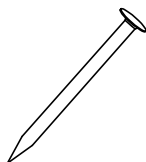

- Q) cód. 30000782 100 un.

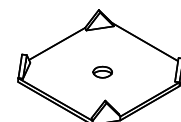

- R) cód. 30001164 032 un.

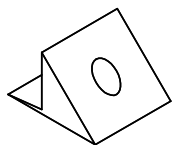

- S) cód. 30001045 066 un.

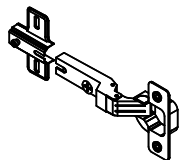

- T) cód. 30014846 026 un.

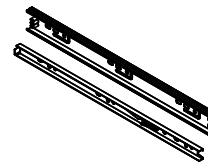

- U) cód. 30013843 006 un.

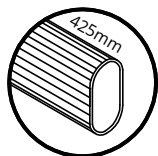

- V) cód. 30011321 002 un.

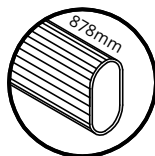

- W) cód. 30005357 002 un.

Perfil Difusor

- X) cód. 30018322 002 un.

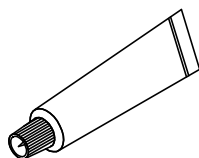

- Y) cód. 30017678 002 un.



- Z) cód. 30018321 003 un.

01

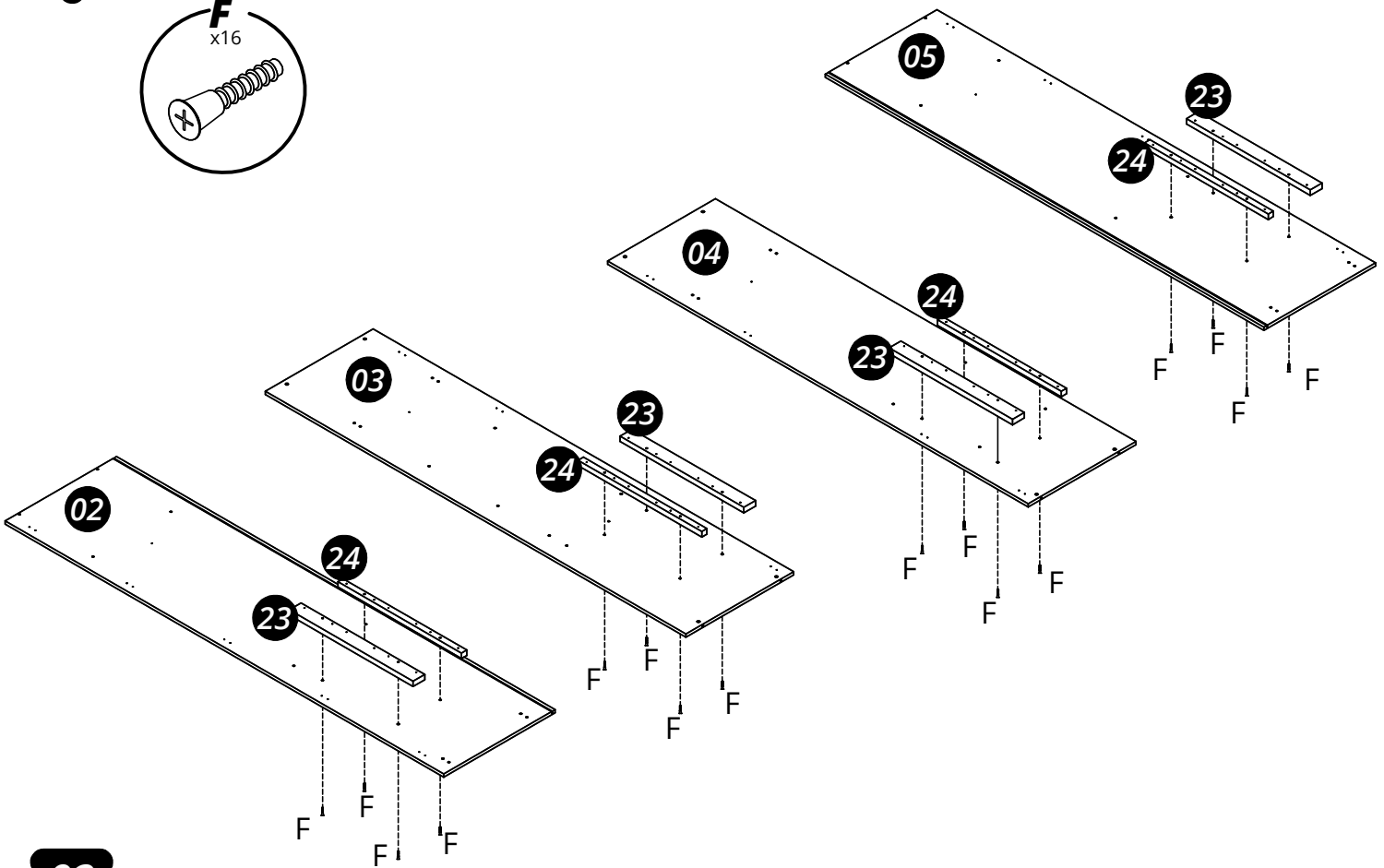
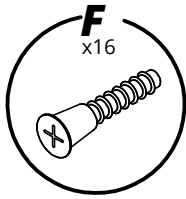

02

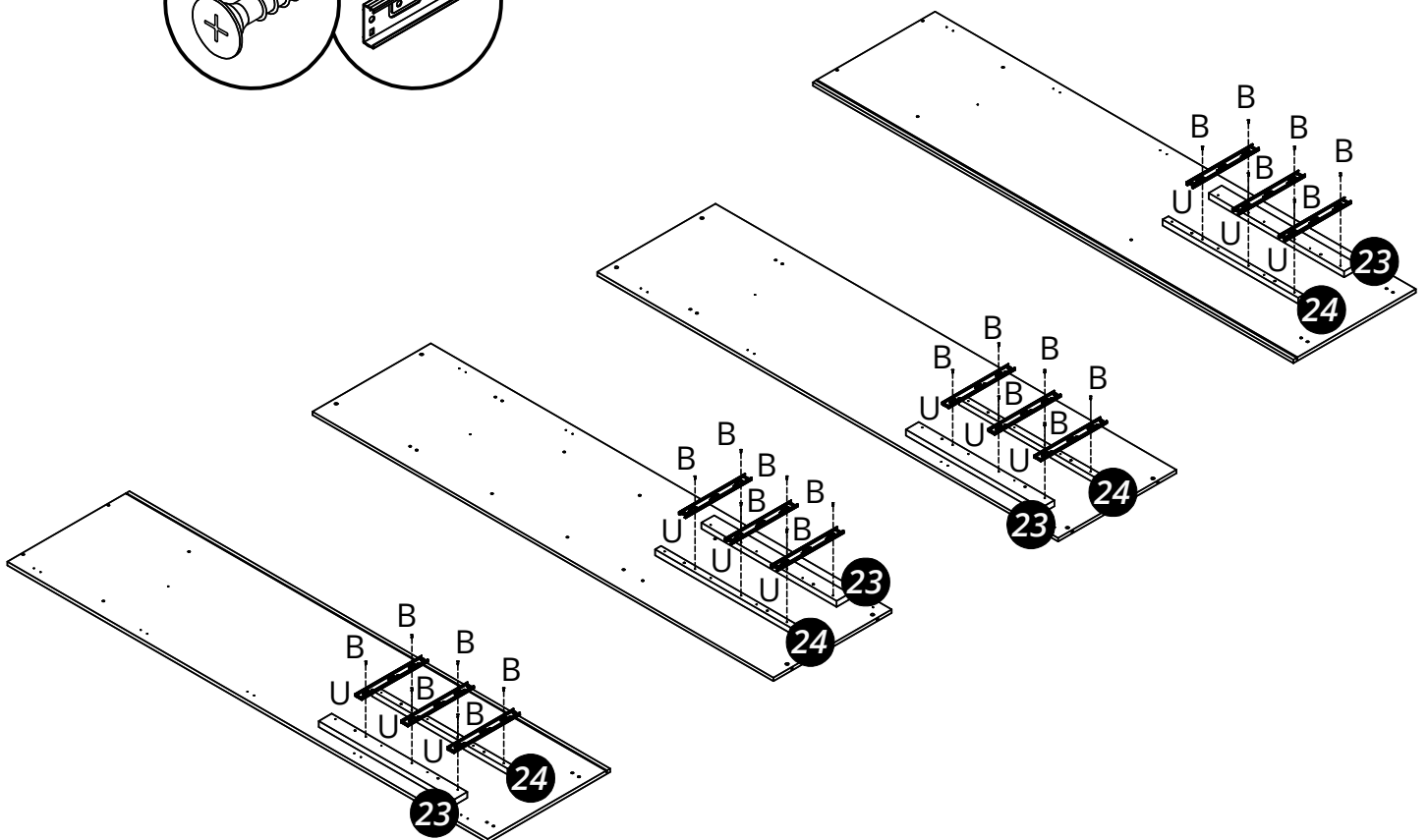
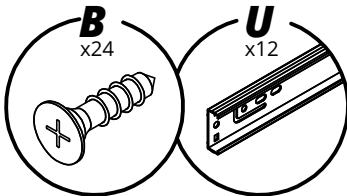

03

Atenção

Utilize o risco como referência para montagem da trava de rodapé.

Atención

Utilice el riesgo como referencia para montar la traba del rodapé.

Attention

Use the risk as a reference for mounting the smaller crossbar.

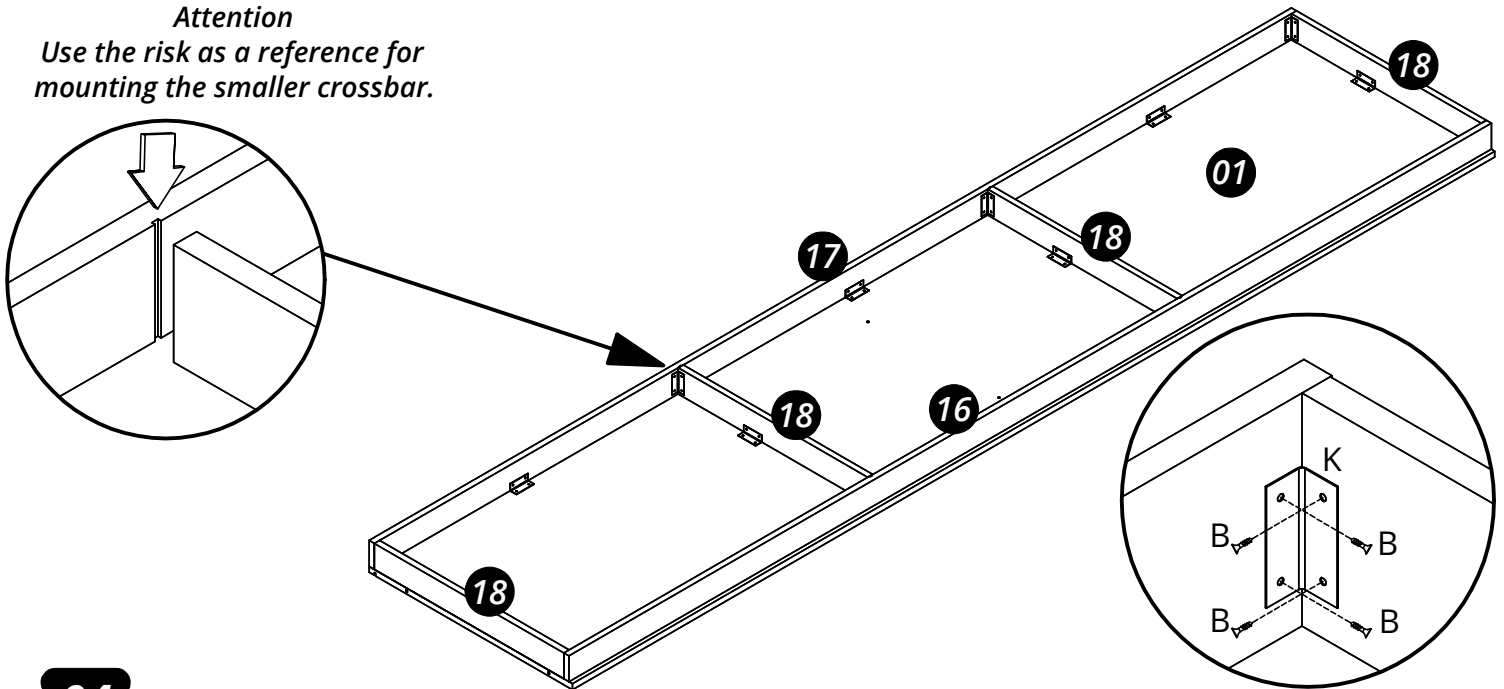
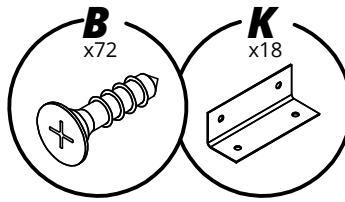

04

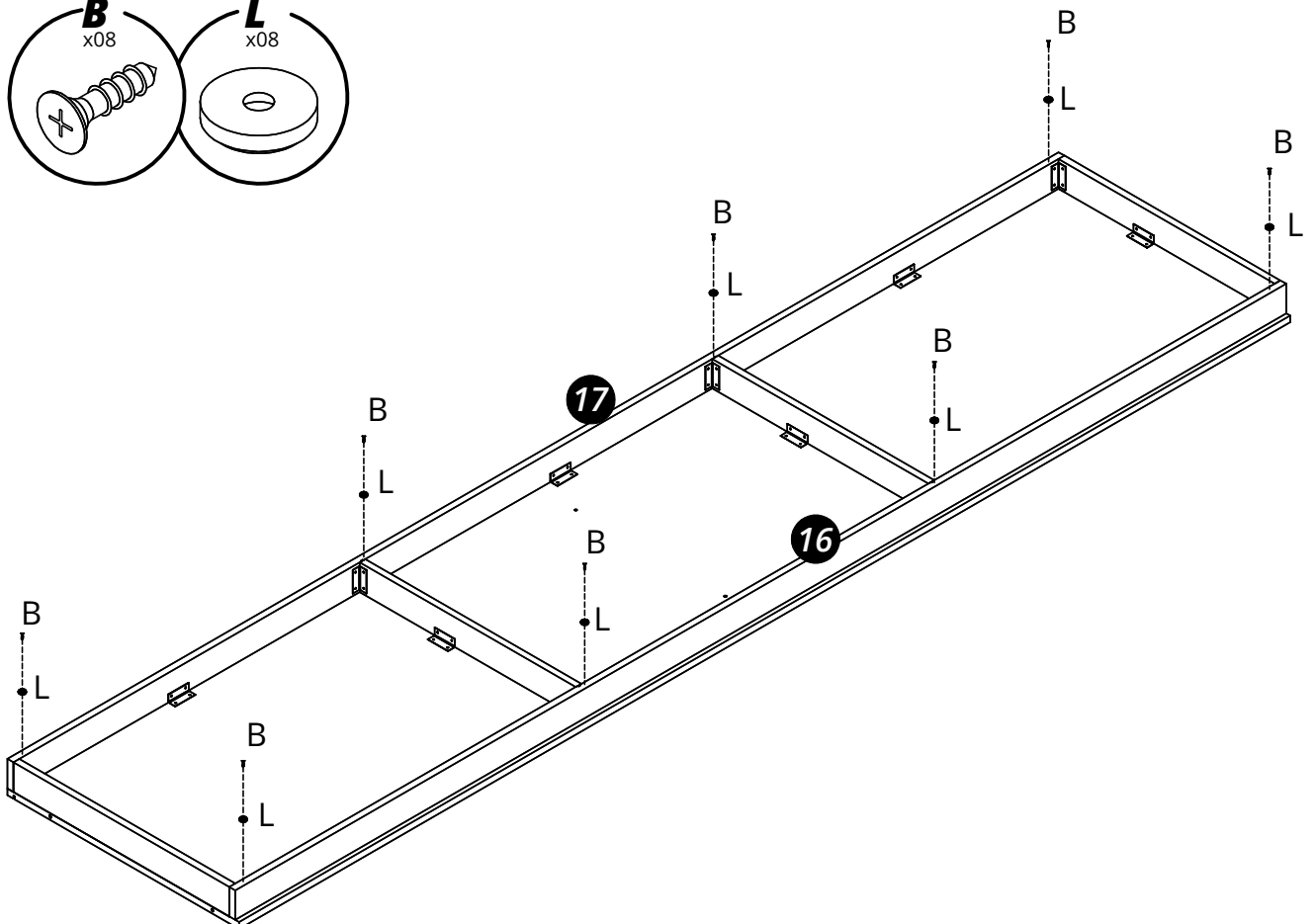
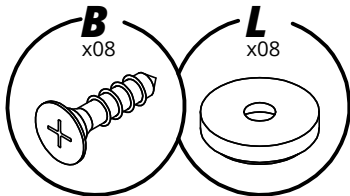

05

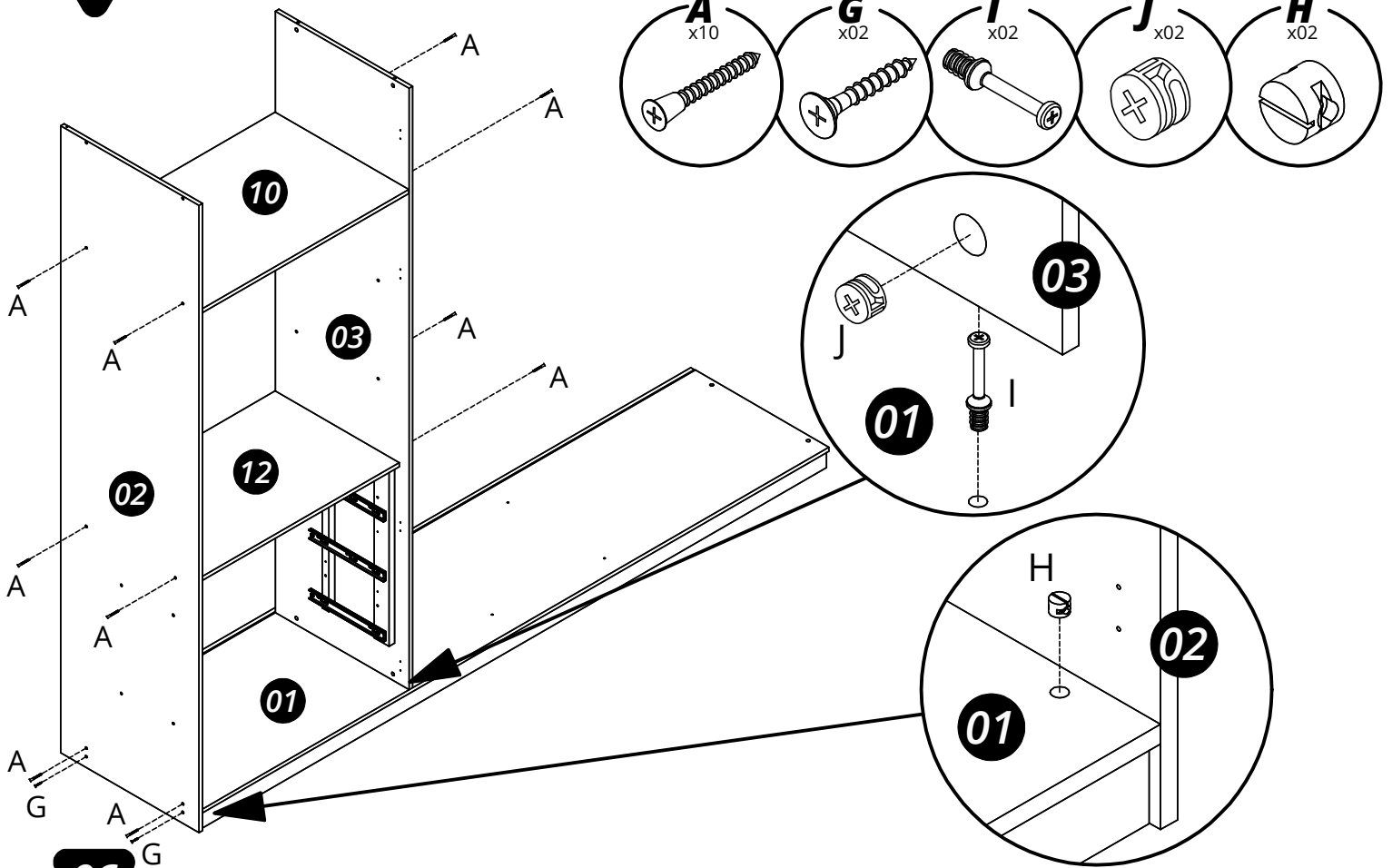

06

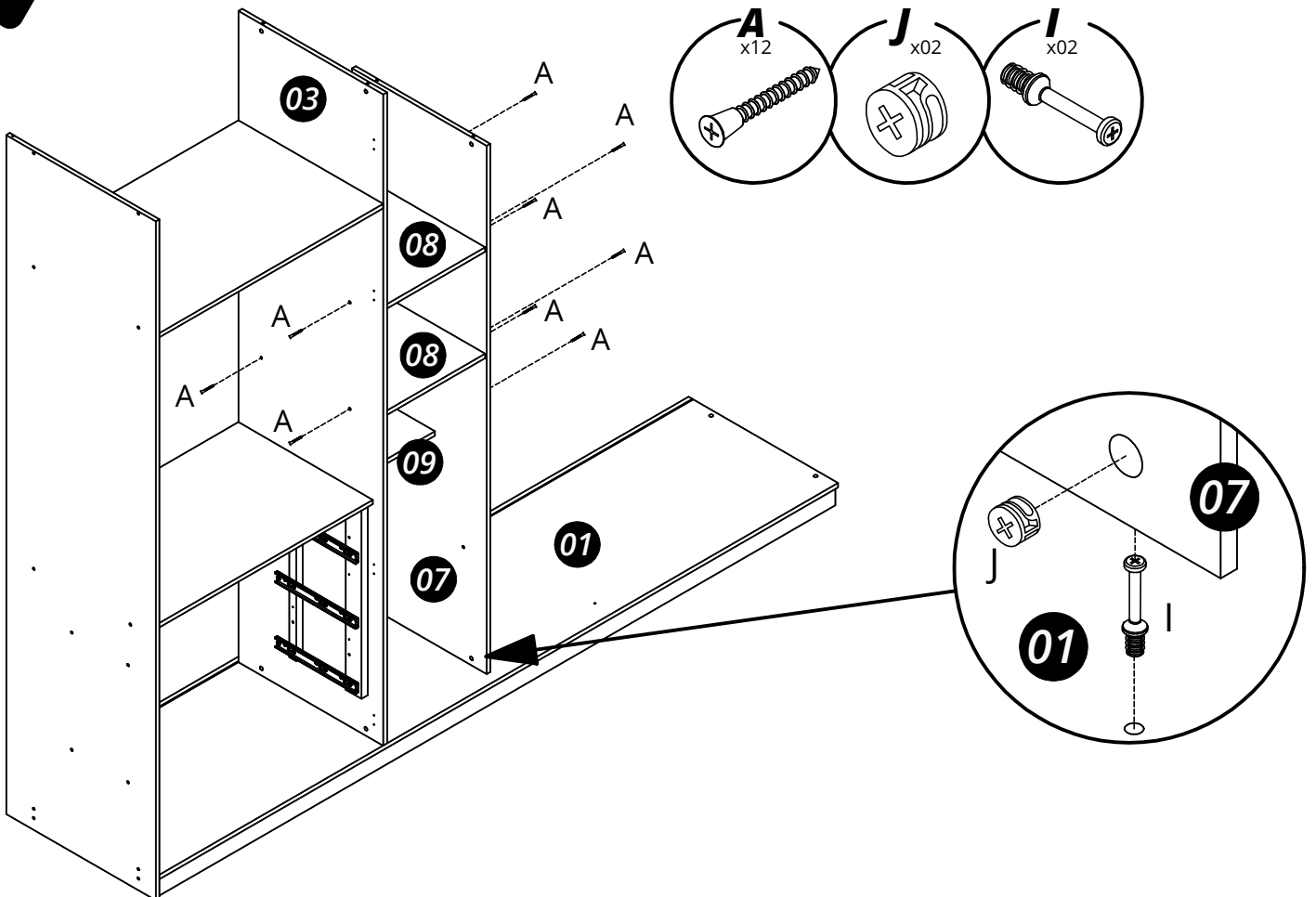

07

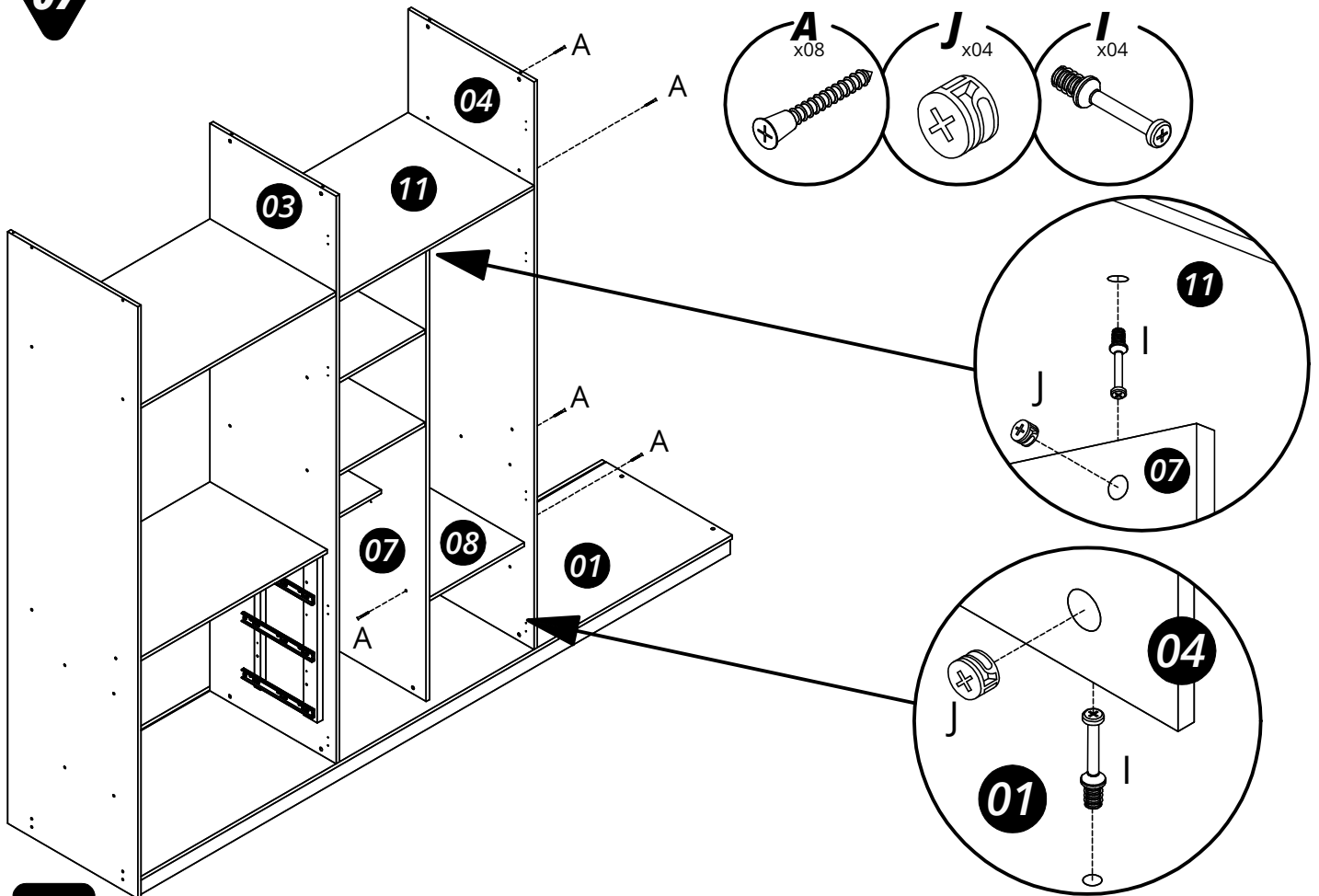

08

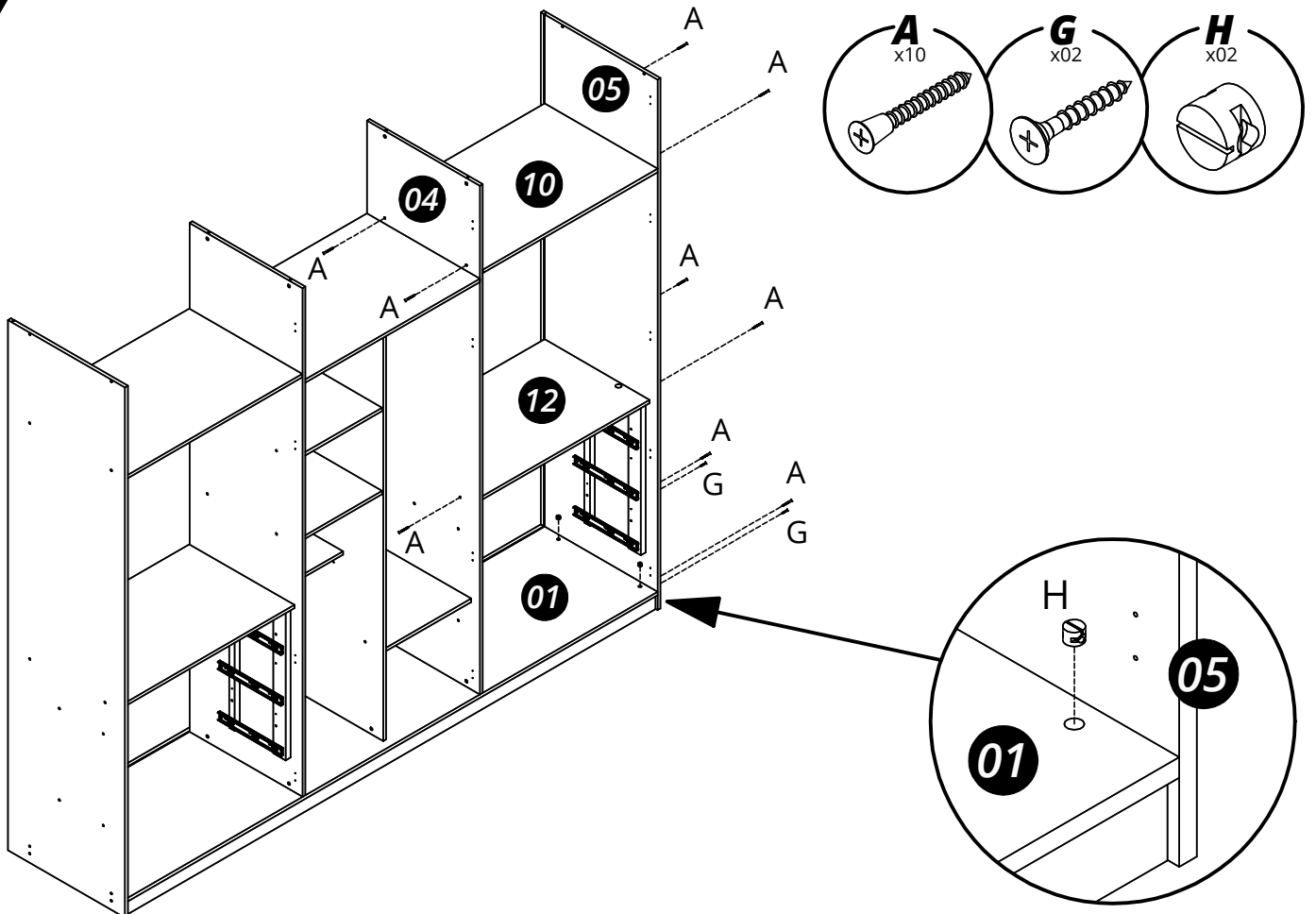

09

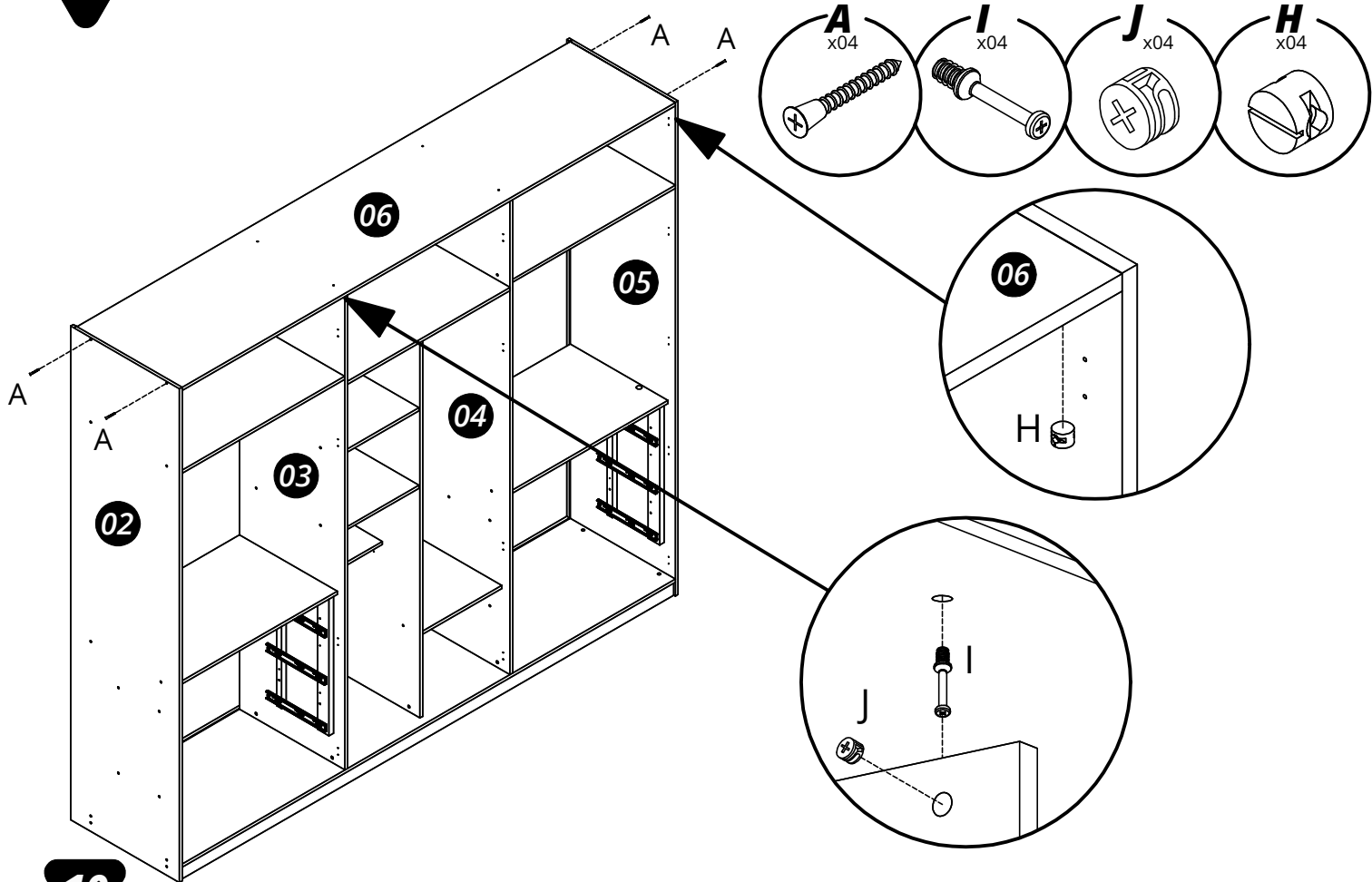

10

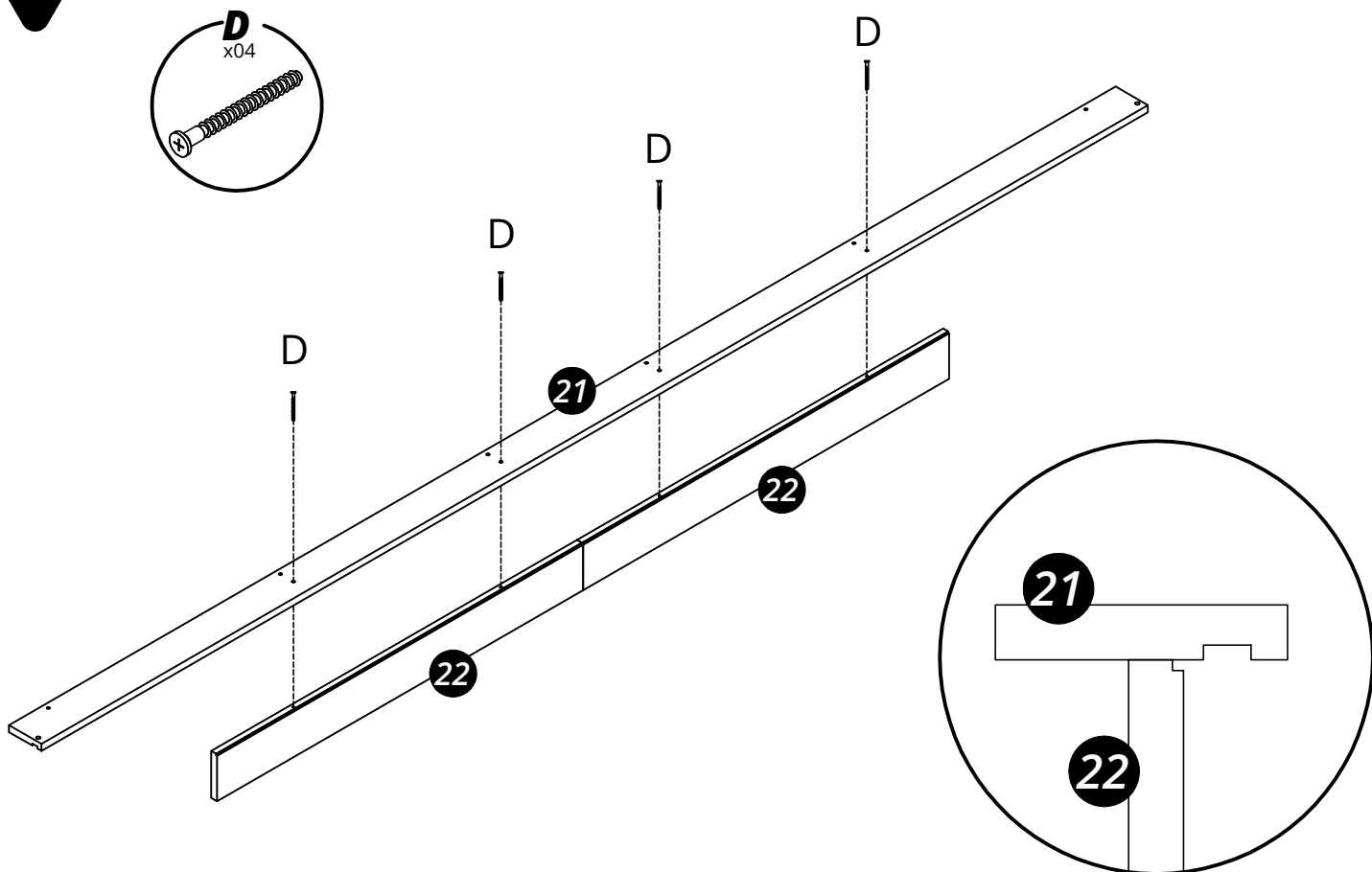

11

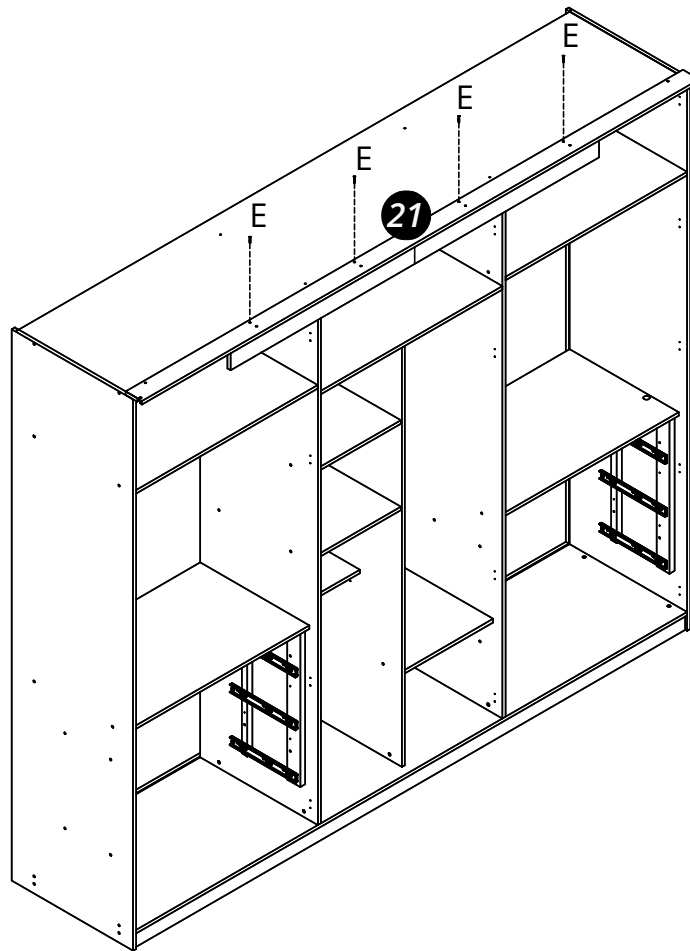
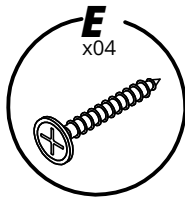

12

Instalação do Kit Led

*Escolher em qual lado instalar o início da fita led, passar a fita pelo furo da moldura e colar no canal.

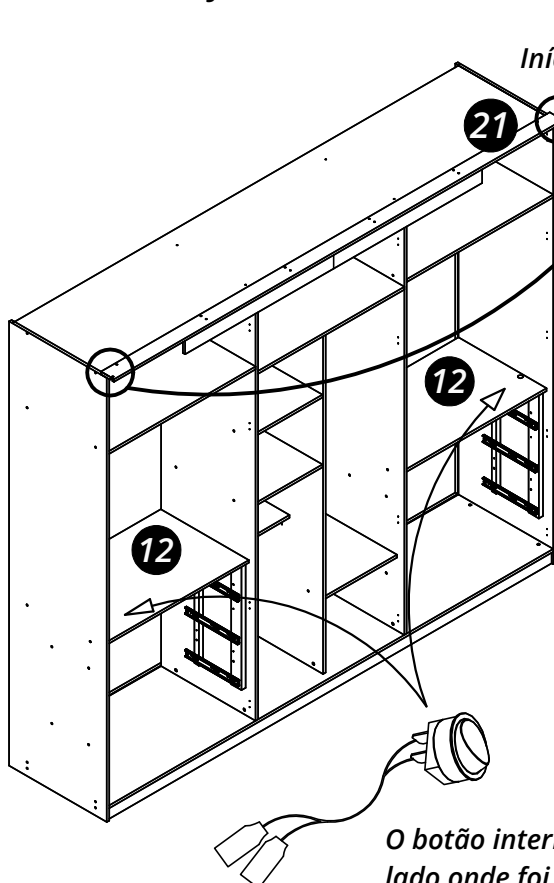

O botão interruptor deve ser instalado do mesmo lado onde foi instalado o início da fita led

Início da fita de Led

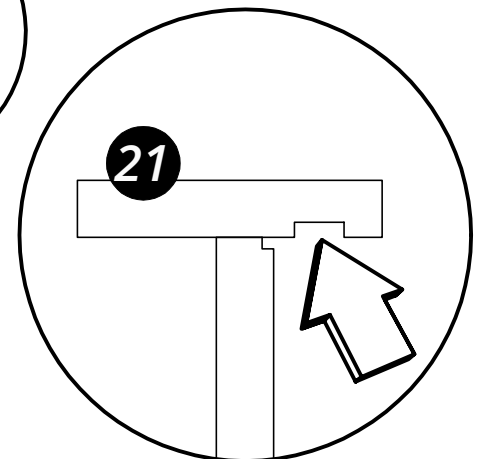
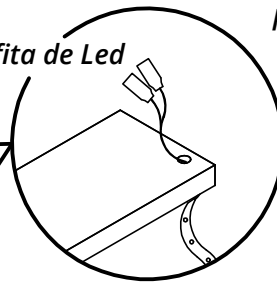

Após instalar a fita de Led.
Encaixar o perfil de acabamento do Led.

Perfil de acabamento do Led

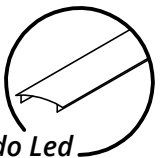

13

O fundo furado deve ser instalado do mesmo lado onde foi instalado o botão liga/desl.

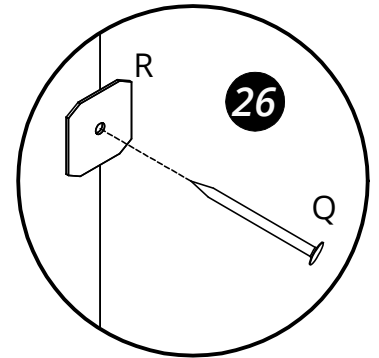
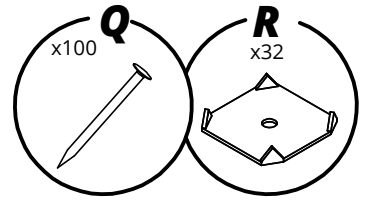
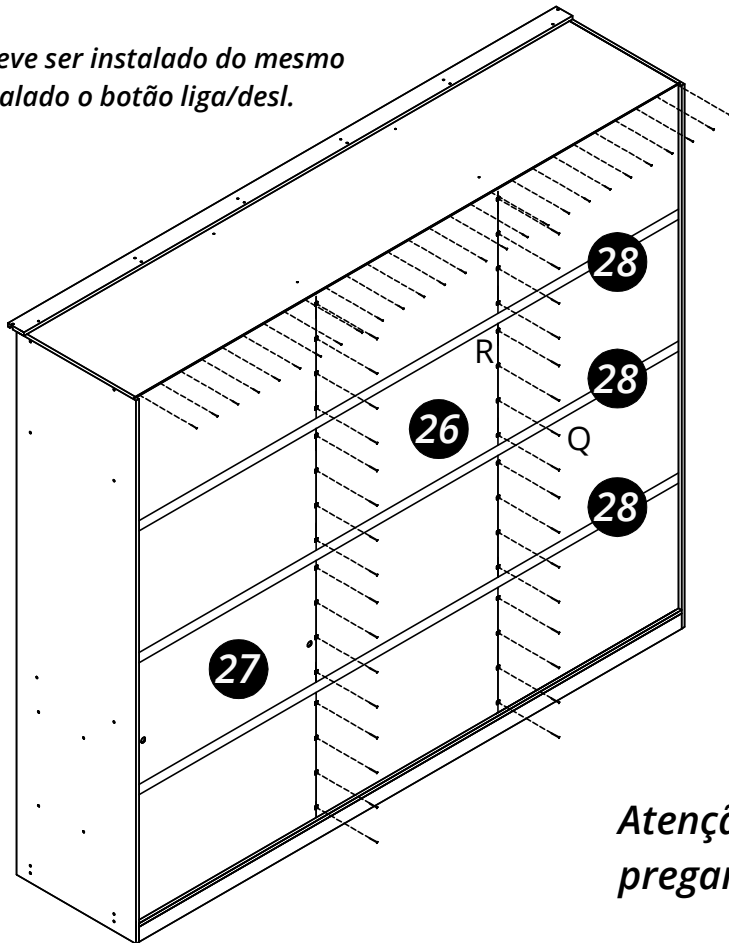

Atenção: Orientamos também, pregar os fundos nas prateleiras.

14

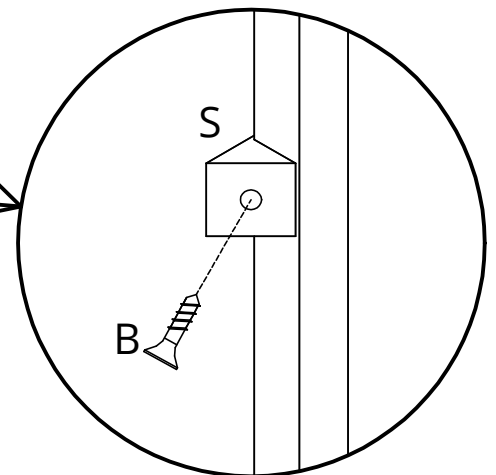
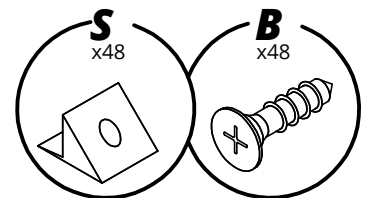
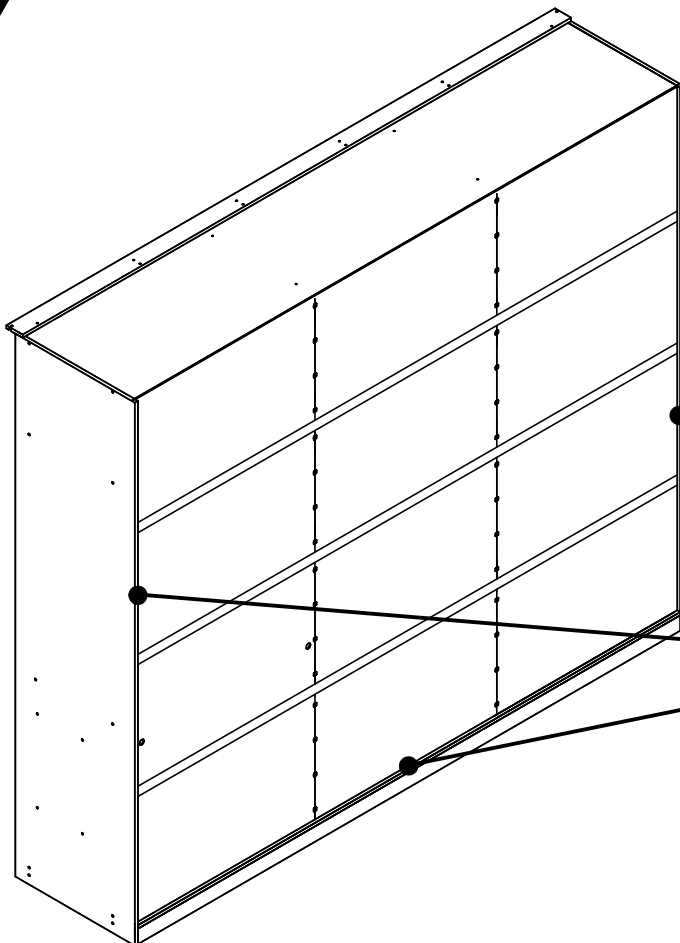

15

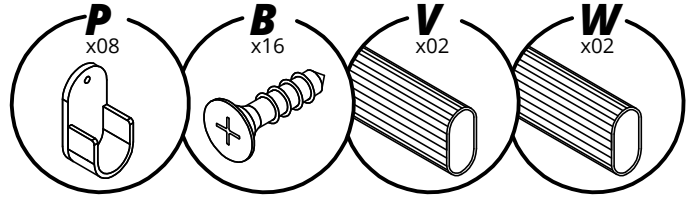
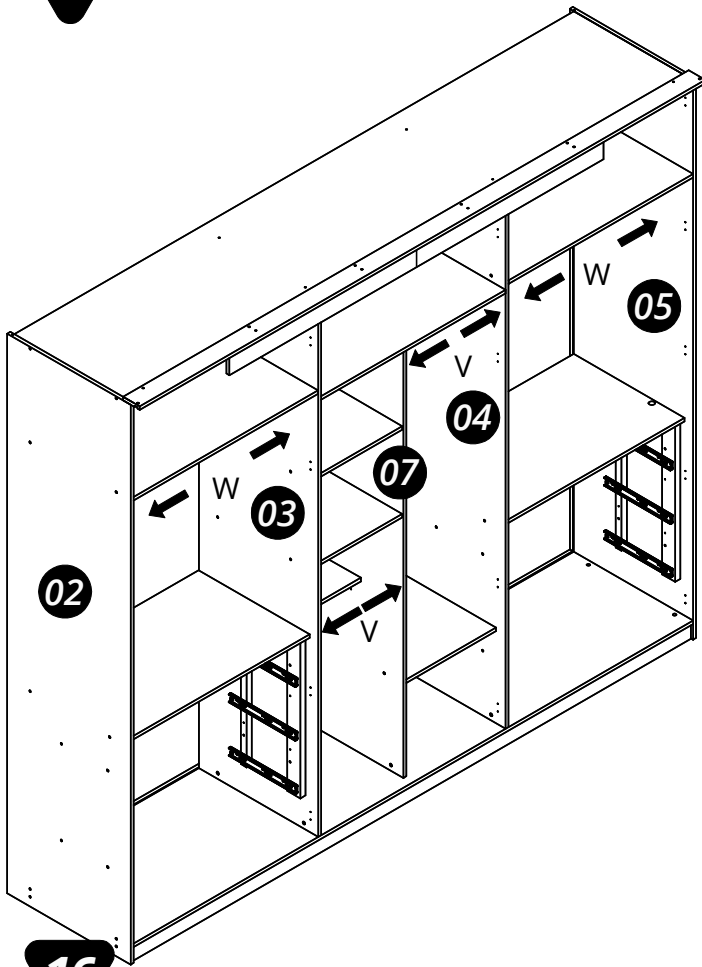

Instruções para instalação do suporte cabideiro.

Guiar o parafuso de baixo na marcação.

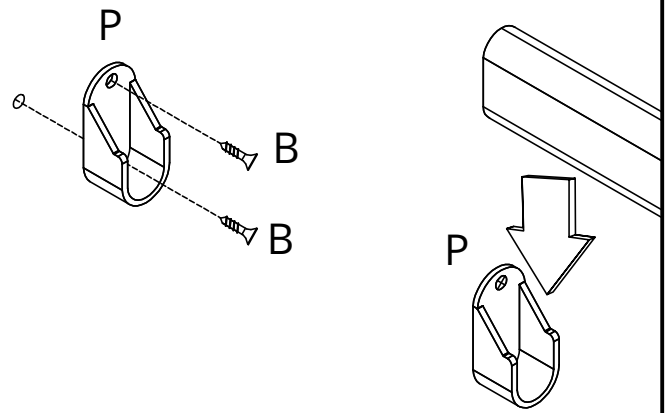

16

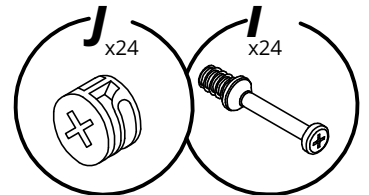
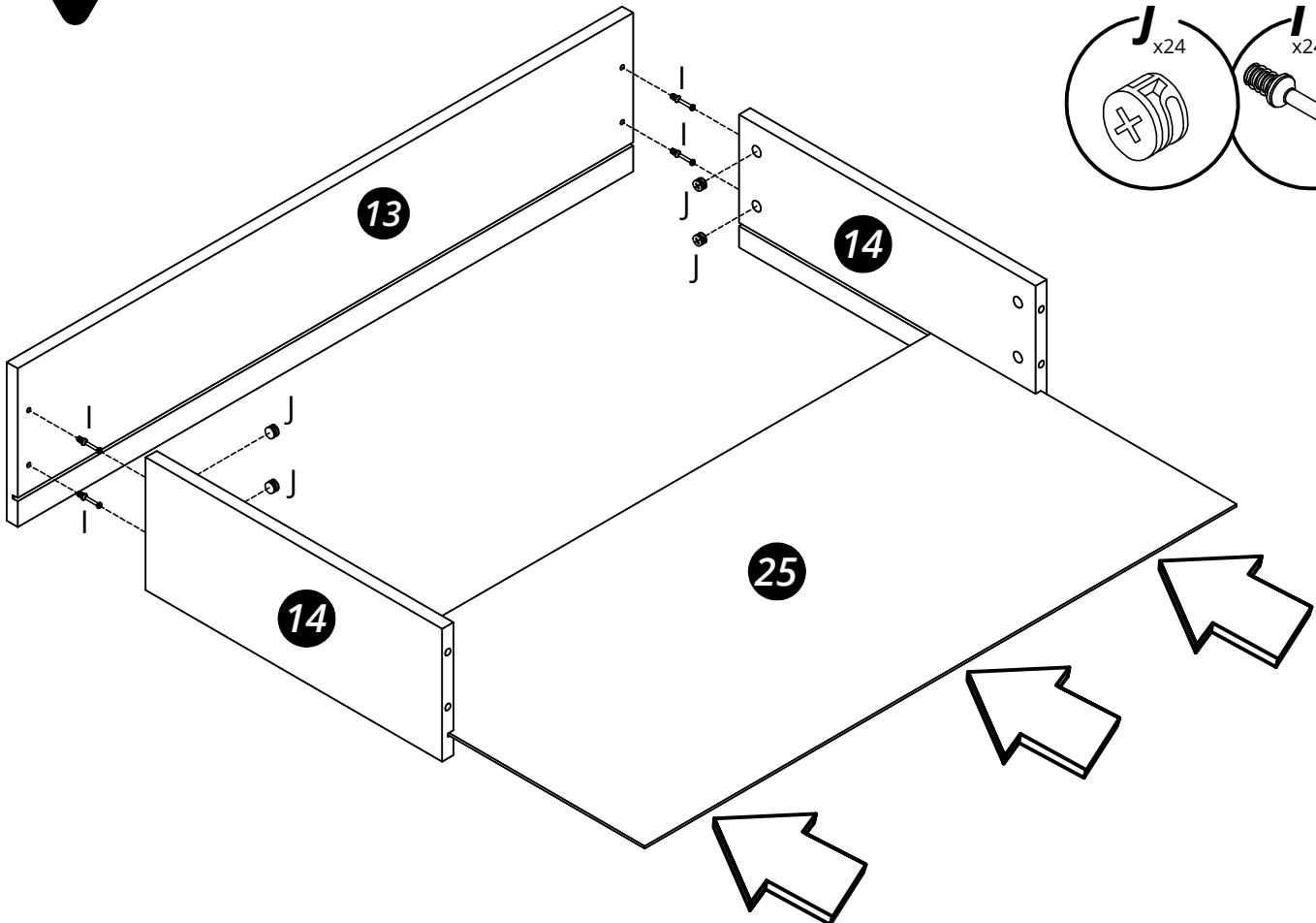

17

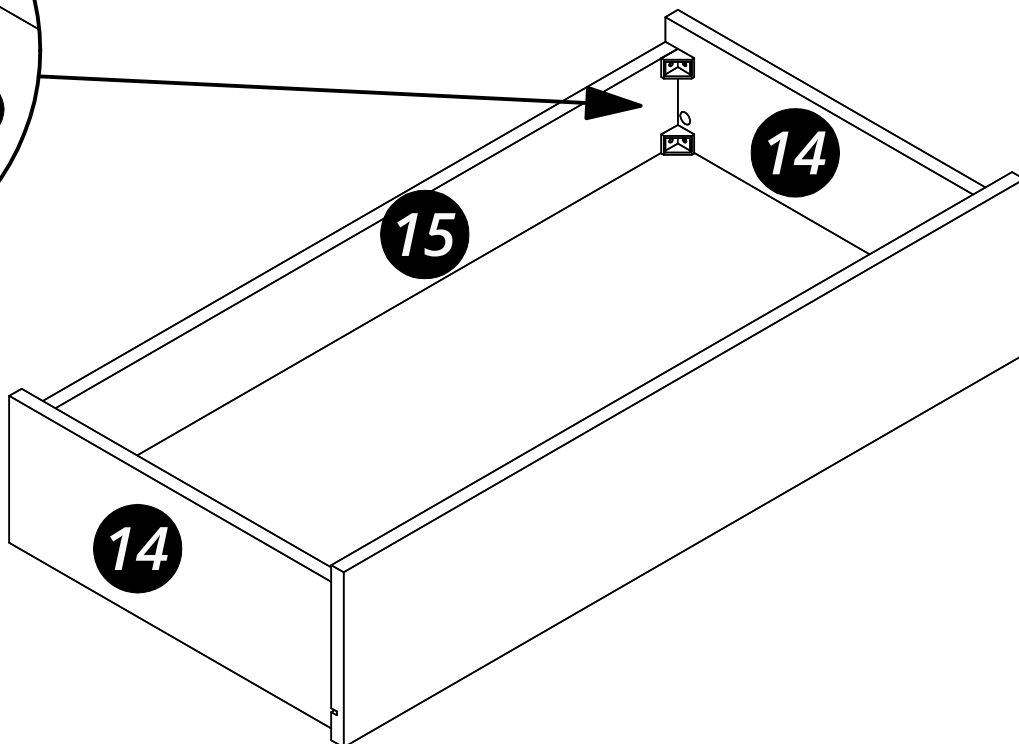
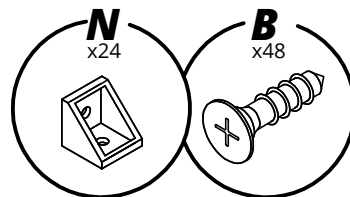
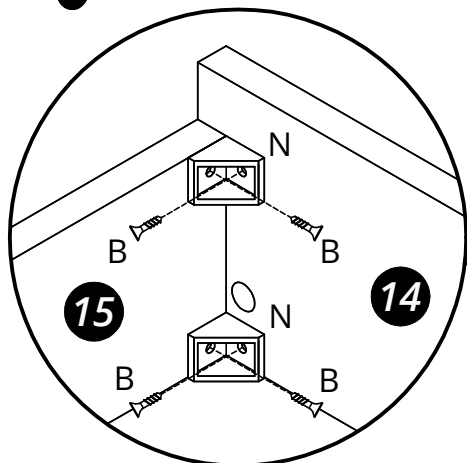

18

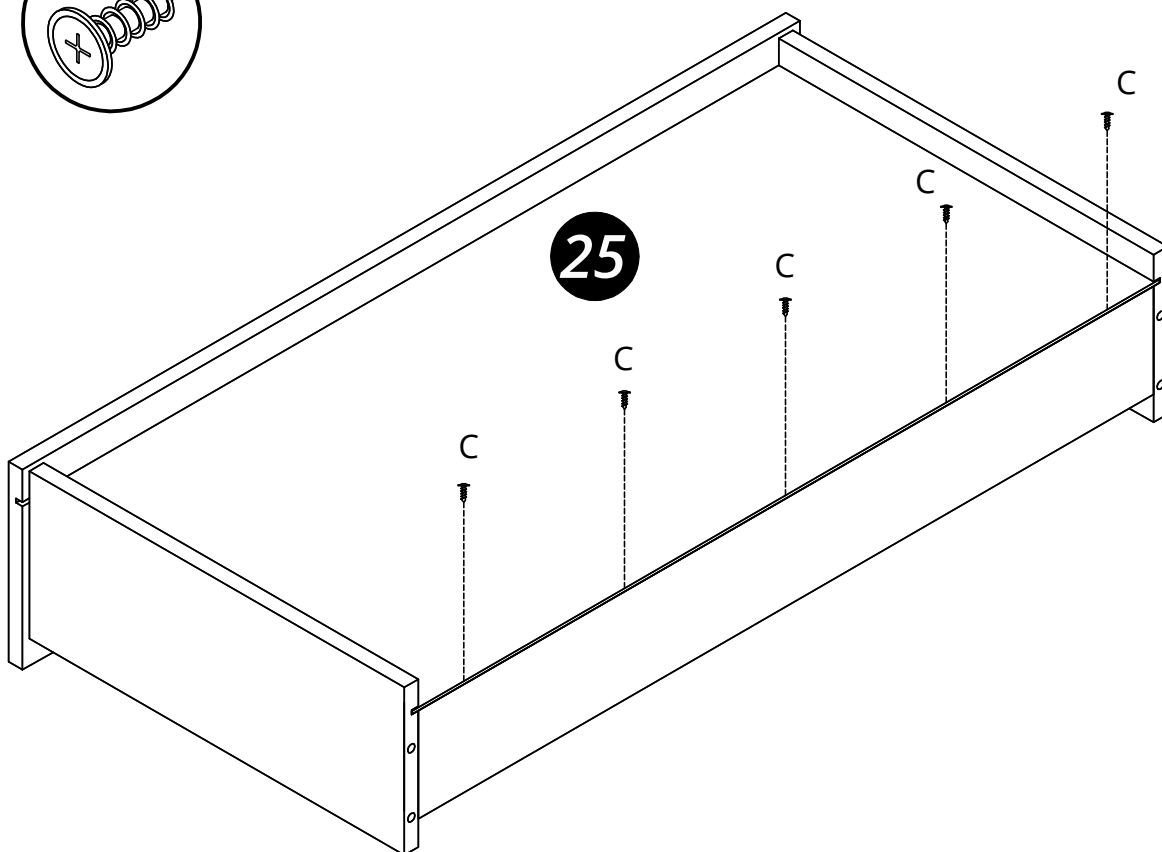
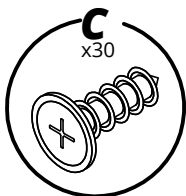

19

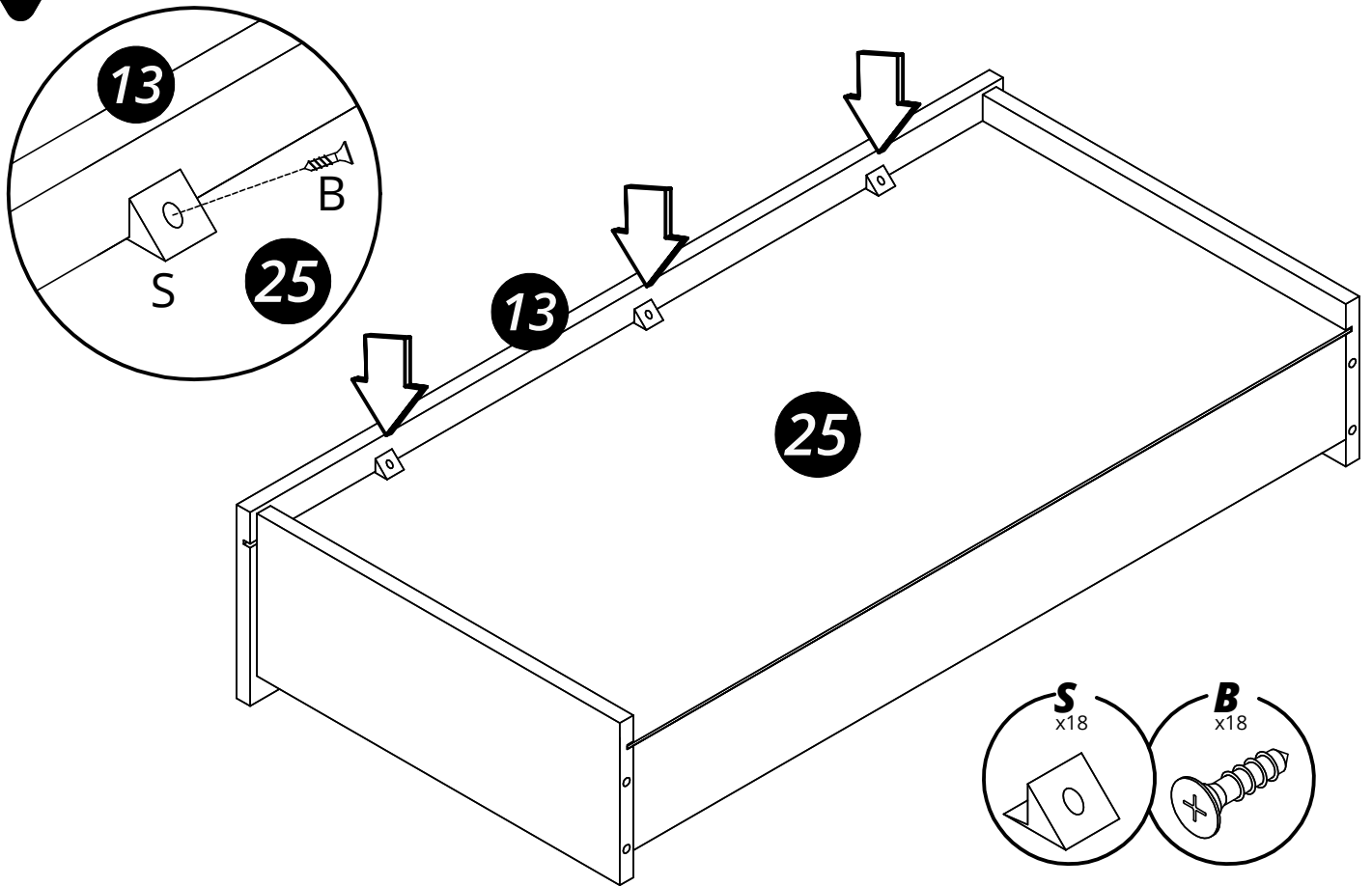

20

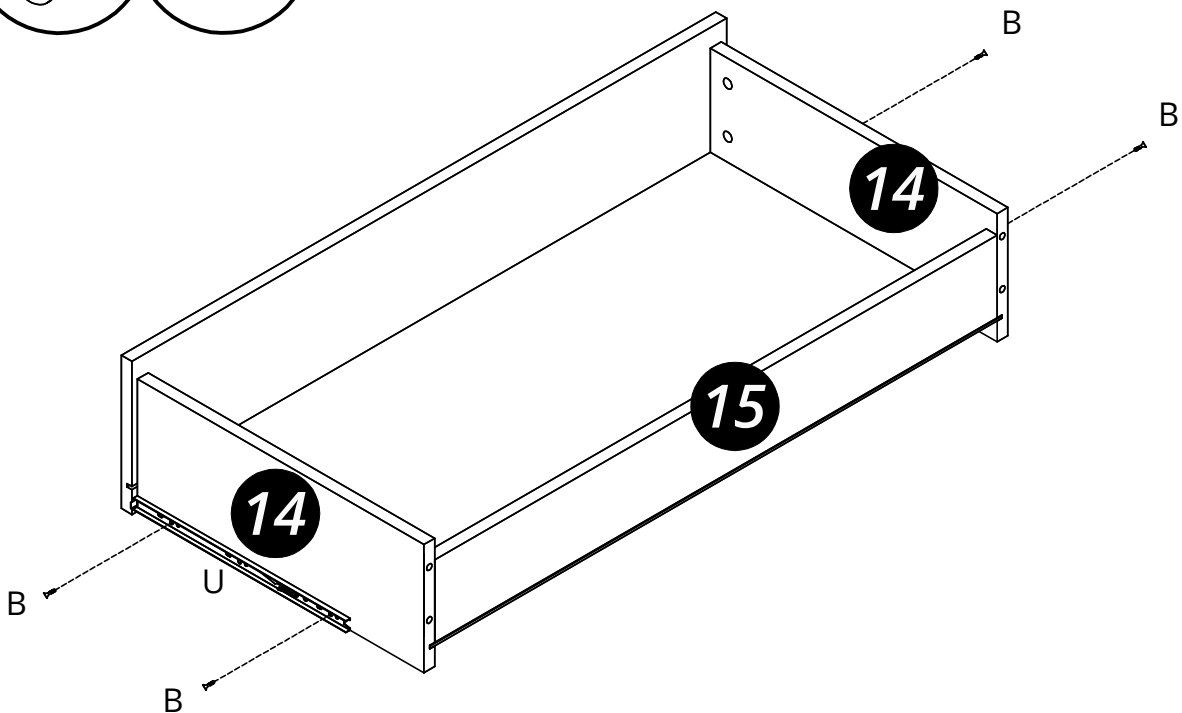
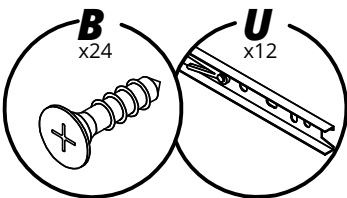

21

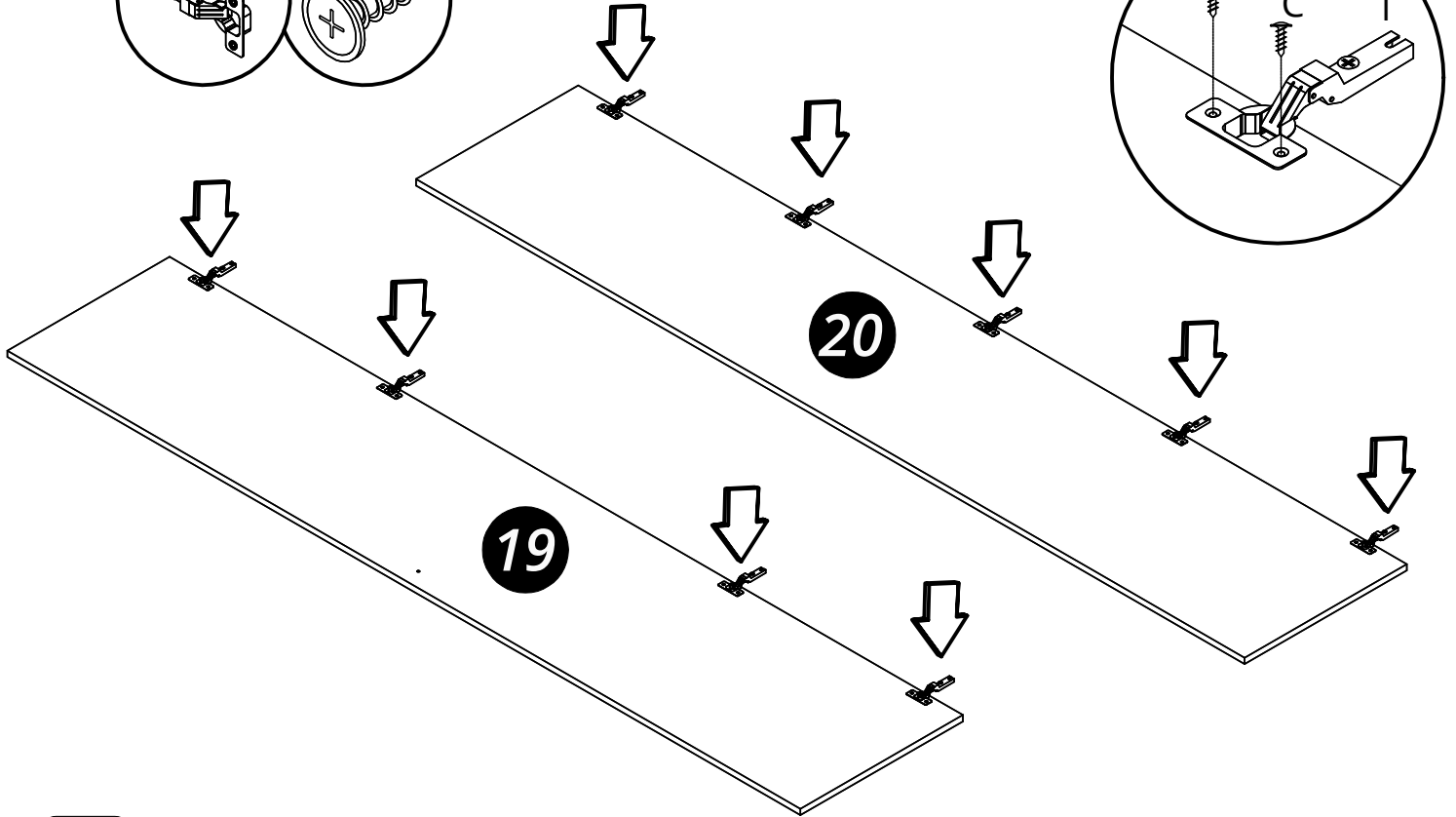
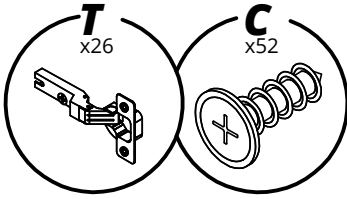

22

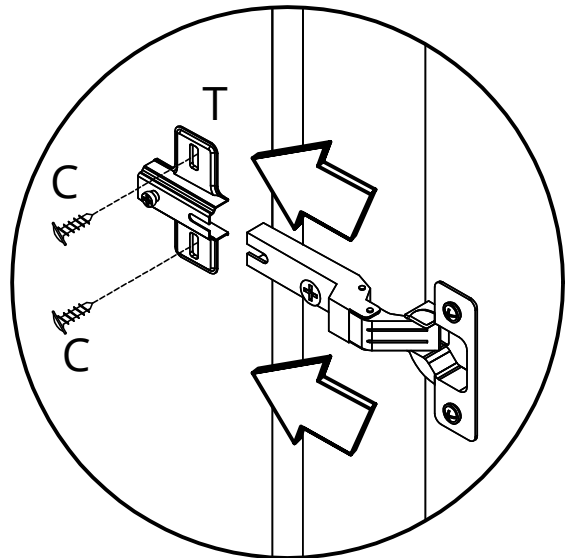
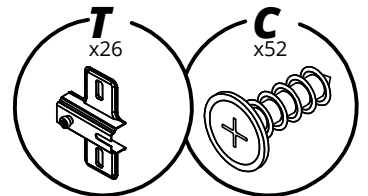
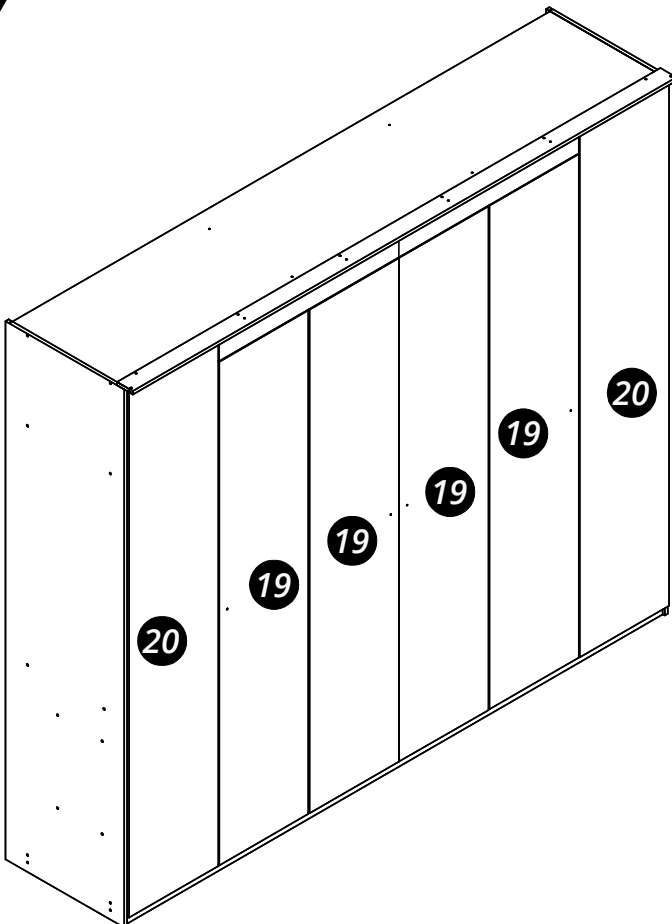

23

Utilize a caixa de embalagem para forrar o chão para montagem da porta.

- Com um pano seco, limpe a superfície dos espelhos e da porta.
- Retire as películas protetoras da fita dupla-face dos espelhos.
- Aplique a cola de espelho nos pontos indicados
- Importante: após aplicar, não esparramar a cola.

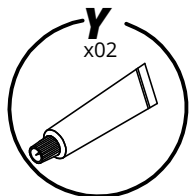

Tempo mínimo de secagem da cola: entre 12 e 24 horas.

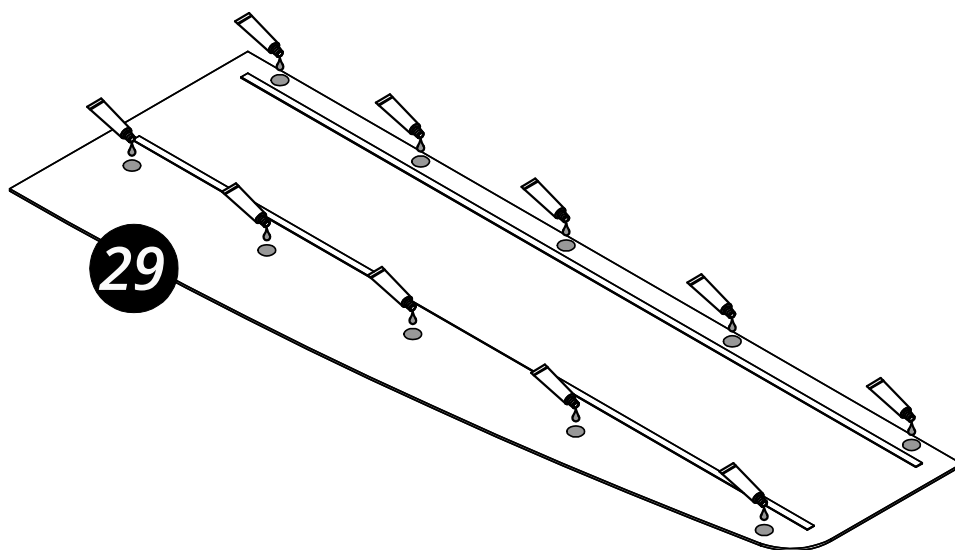

24

Fixação do Espelho

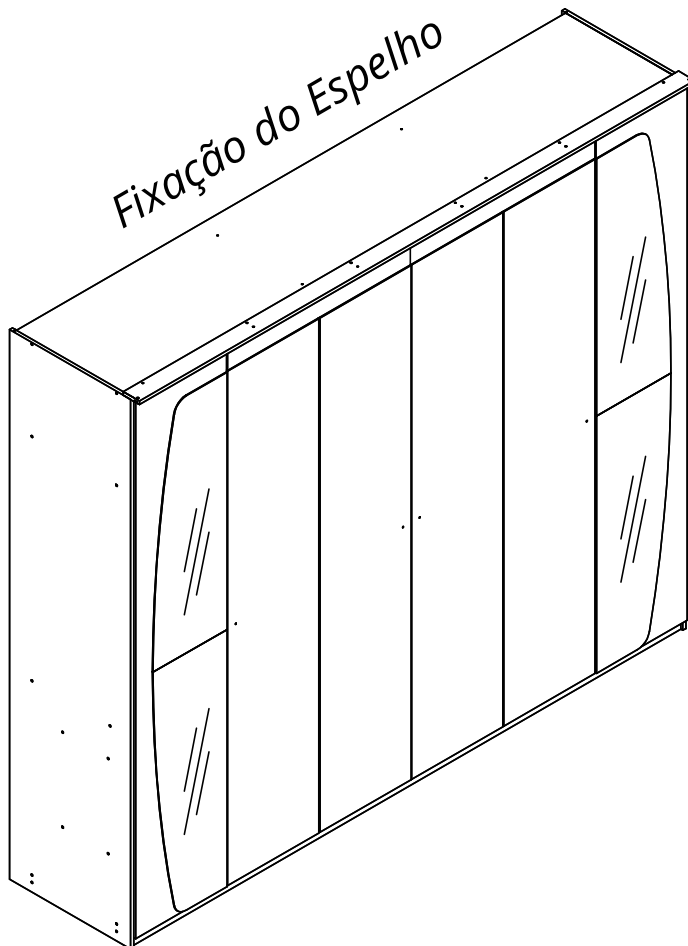

25

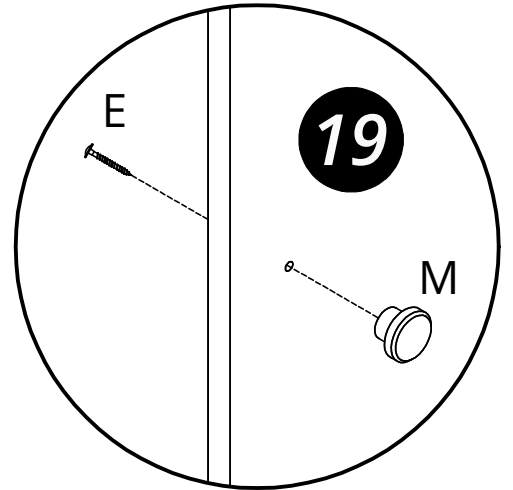
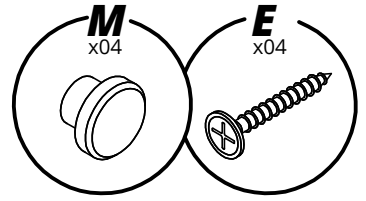
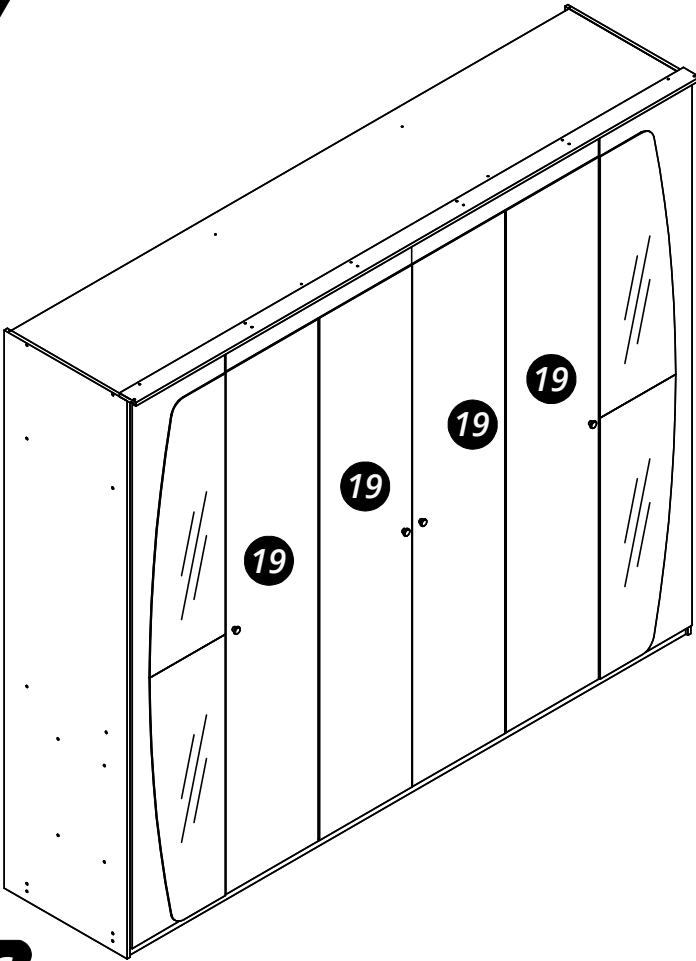

26

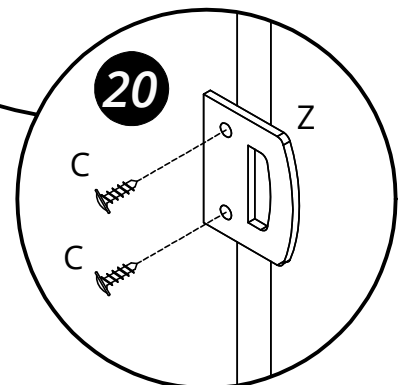
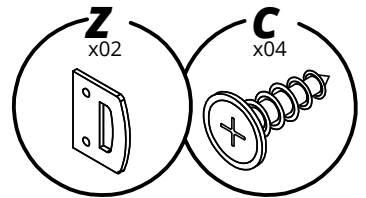
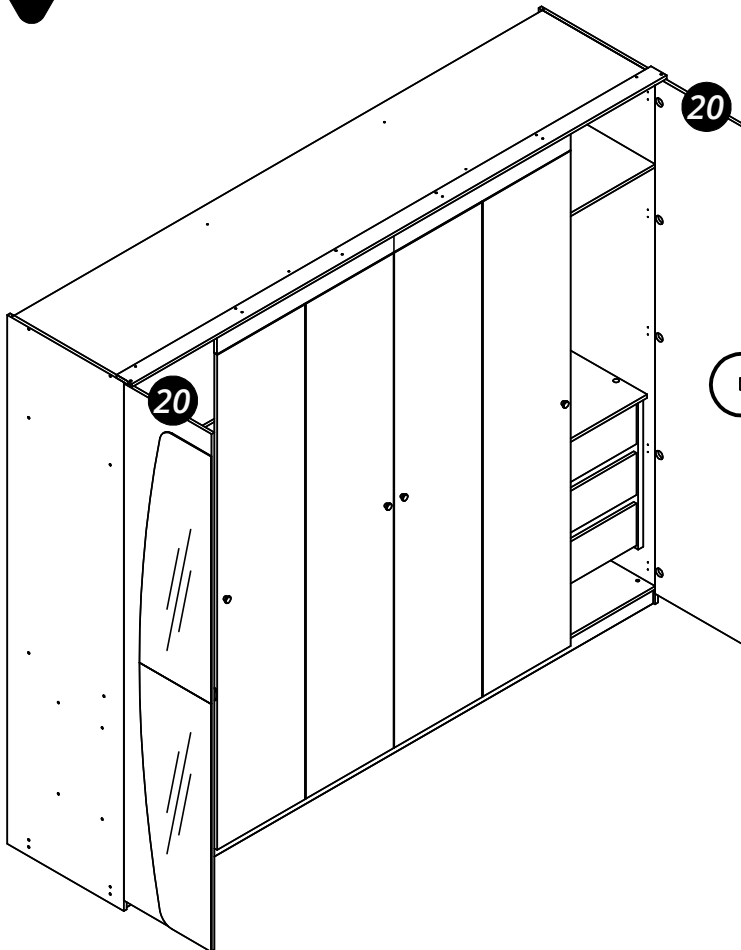

Agora que você já comprou o seu móvel, ele merece ser montado do jeito certo.

Erros de montagem causam mais de **60%** dos danos em móveis.

Por que contratar?

Tranquilidade do **início ao fim** da montagem



PROFISSIONAIS QUALIFICADOS

Especialistas certificados na **MadeiraMadeira Serviços**.



FERRAMENTAS PROFISSIONAIS

que **protegem** seus móveis.



AGENDAMENTO EM 24 HORAS

escolha a data e o turno **ideais para** você.



GARANTIA DE 3 MESES

de cobertura **completa**.

Mais de 1 MILHÃO DE MONTAGENS
★ com avaliação 4.7 ★

Mariana S., São Paulo

"Chegaram no horário e montaram tudo rapidamente. Serviço incrível!"



Carlos R., Belo Horizonte

"Tentei montar sozinho e foi um desastre. Com a **MadeiraMadeira Serviços** ficou perfeito."



Ana P., Rio de Janeiro

"Agendamento ágil e **montagem pontual e perfeita**. Recomendo demais!"



Agende agora pelo
QR Code

Madeira**Madeira** Serviços · Atendimento em todo o Brasil



Escaneie o QRCode