

INSTRUÇÕES DE MONTAGEM

INSTRUCCIONES DE MONTAJE ASSEMBLY INSTRUCTIONS

Cômoda Infantil 05 Gavetas Lápis de Cor

Referência/Cor

- IE78-10 - Branco
 IE78-18 - Rústico/Branco

Requisitos para montagem Requisitor para la montaje Assembly Requirements

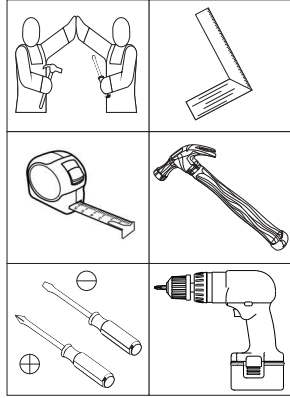

Imagens meramente ilustrativas
Imágenes meramente ilustrativas
Images for illustration only

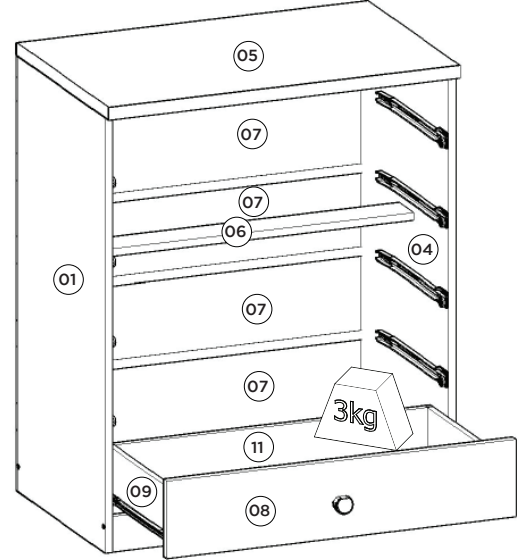
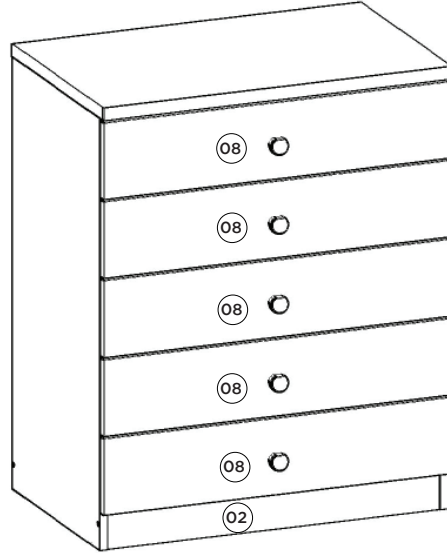

Pesos máximos recomendados com carga distribuída
Peso máximo recomendado con la carga distribuida
Recommended maximum weights with evenly distributed.

Lista de Peças | Lista de piezas | List of parts

Item	Caixa Caja Box	Qtd Ctd Qty	Descrição Descripción Description	Medidas (mm) Dimensions (mm) Size (measurements) (mm)
01	1/1	01	Lateral esquerda Lateral izquierda Left side	899x375x15
02	1/1	01	Rodapé frontal Rodapié frontal Front skirting	718x73x12
03	1/1	01	Rodapé traseiro Rodapié trasero Rear skirting	718x73x12
04	1/1	01	Lateral direita Lateral derecha Right side	899x375x15
05	1/1	01	Tampo Tapa Top	750x395x25
06	1/1	01	Travessa estrutural Travesaño estructural Structural Strut	718x68x15
07	1/1	05	Fundo cru Fondo sin procesar Raw background	737x165x3
08	1/1	05	Frente de gaveta Frente de cajón Front of drawer	746x160x15
09	1/1	10	Lado de gaveta Lado del cajón Side of drawer	350x110x12
10	1/1	05	Fundo de gaveta Fondo del cajón Drawer bottom	680x361x3
11	1/1	05	Ripa de trás Malla detrás Rear lath	693x110x12

AVISO

Para limpeza de seu móvel, use uma flanela seca ou umedecida, e não utilize produtos químicos que possam danificar seu produto.

SISTEMA DE MONTAGEM

O sistema de montagem dos produtos, funciona de acordo com a ordem crescente dos números indicados no desenho. Ex: 01, 02, 03, 04... até a conclusão da montagem.

ADVERTENCIA

Para limpeza de su móvil, use una flanela seca o húmeda, y no utilice productos químicos que puedan dañar su producto.

SISTEMA DE MONTAJE

El sistema de montaje de los productos funciona de acuerdo con el orden creciente de los números indicados en el dibujo. Ej.: 01, 02, 03, 04... hasta la conclusión del montaje.

NOTICE

To clean your furniture, use a dry or wet cloth, and do not use chemicals that may damage your product.

ASSEMBLY SYSTEM

The products' assembly system works according to the increasing order of the indicated numbers. For example: 01, 02, 03, 04 ... to the end of the assembly.

Ferragens | Herrajes | Hardware

A Parafuso 4,5x50mm CHT. Tornillo 4,5x50mm CHT. Screw 4,5x50mm CHT.	04x	B Parafuso 3,5x25mm FLA. Tornillo 3,5x25mm FLA. Screw 3,5x25mm FLA.	05x	C Parafuso 3,5x14mm FLA. Tornillo 3,5x14mm FLA. Screw 3,5x14mm FLA.	10x	D Parafuso 3,5x12mm CHT. Tornillo 3,5x12mm CHT. Screw 3,5x12mm CHT.	70x	E Parafuso 3,0x16mm CHT. Tornillo 3,0x16mm CHT. Screw 3,0x16mm CHT.	10x	F Cantoneira plástica Cantонера plástica Plastic angle brackets	14x	G Cavilha 5x25mm Cinta 5x25mm Dowel 5x25mm	48x
H Zapata "L" 16x20mm "L" shoe 16x20mm	04x	I Prego 12x12mm Anelado Clavo 12x12mm Anillado Ringed Nails 12x12mm	14x	J Prego 10x10mm Clavo 10x10mm Nail 10x10mm	26x	K Porca cilíndrica Tuerca cilíndrica Cylindrical nut	04x	L Puxador Pontual Reality Tirador Puntual Reality Reality Punctual Knob	05x	M Cantoneira suporte triangular Cantонера soporte triangular Triangle support angle	10x	N Corrediça metal 350mm Corredera de metal 350mm Sliding metal 350mm	05x
O Perfil "H" 728mm Perfil "H" 728mm Profile "H" 728mm	04x	P Sachê de cola Bolsa de pegamento Glue bag	02x	Q Adesivo tapan parafuso 10mm Adhesivo tapón de tornillo 10mm Bolt cover adhesive 10mm	04x	R Parafuso 5,0x50mm FLA. Tornillo 5,0x50mm FLA. Screw 5,0x50mm FLA.	01x	S Buchas plásticas 8mm Bucha de plástico 8mm 8mm plastic bushing	01x	T Suporte de fixação Soporte de fijación Mounting bracket	01x		

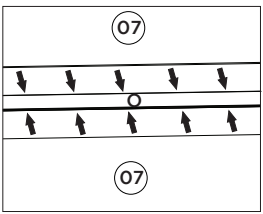
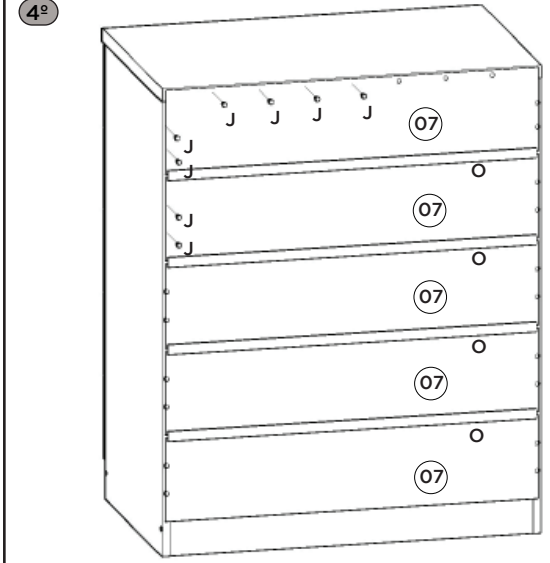
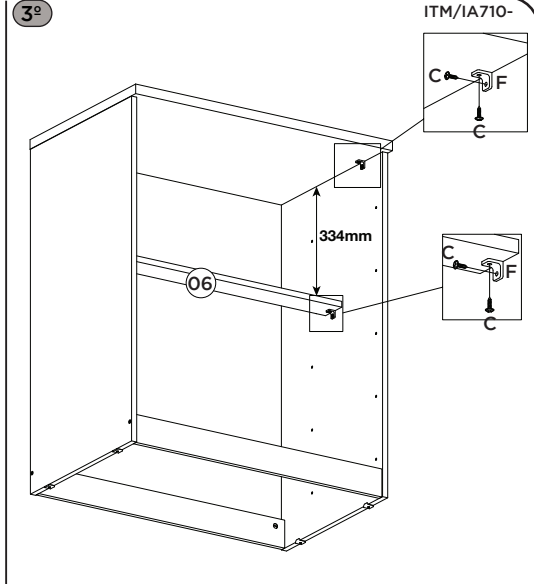
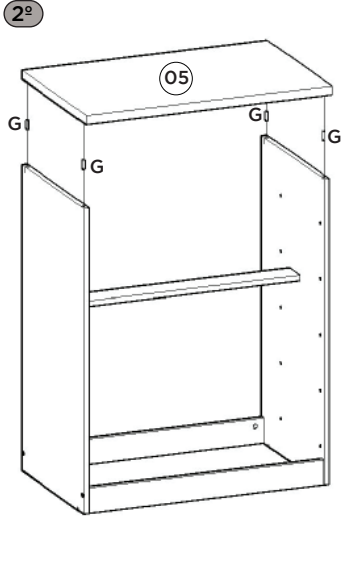
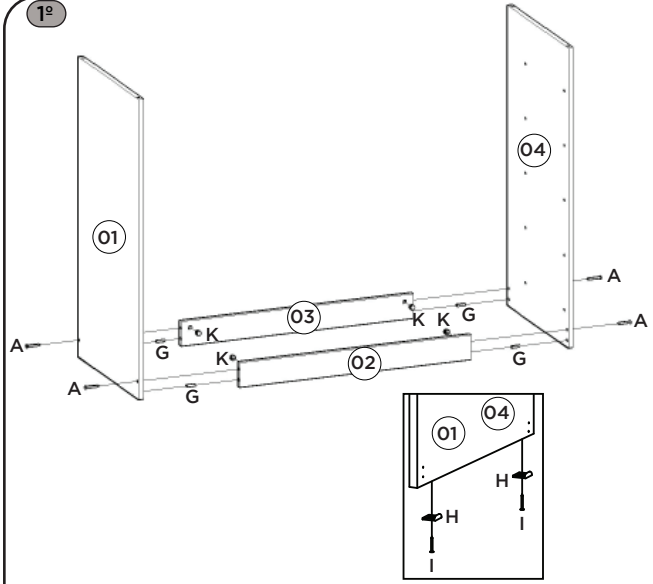

Vídeo: Dicas para instalar corredeira
 Video: consejos para instalar la diapositiva
 Video: Tips for installing slide

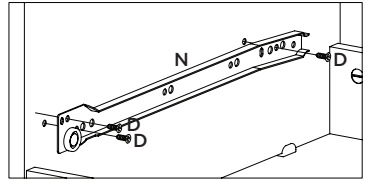

Imprescindível a fixação do produto na parede, a não colocação destas ferragens para fixação (C, R, S e T), poderá permitir que o produto vire, causando acidente.

Es imprescindible la fijación del producto en la pared, la no colocación de estos herrajes para fijación (C, R, S y T), podrá permitir que el El producto se vuelva, causando accidente.

Indispensable to fix the product on the wall, not the placement of these attachment fittings (C, R, S and T) may allow the product to turn, causing an accident.

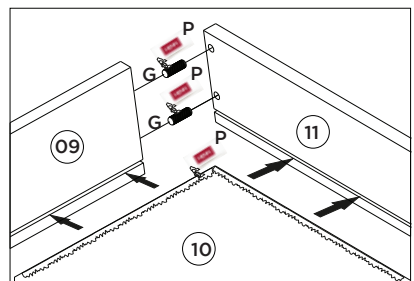
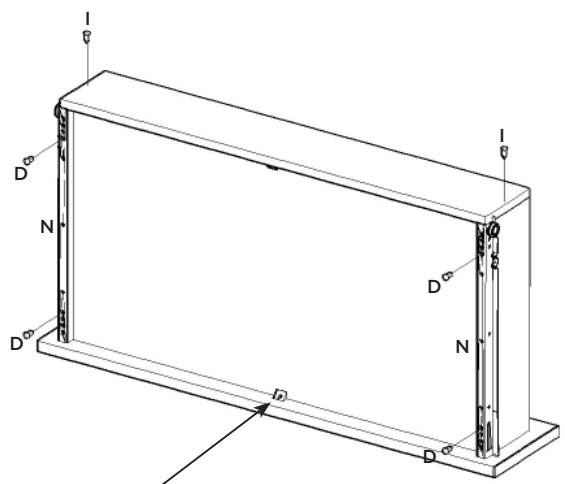
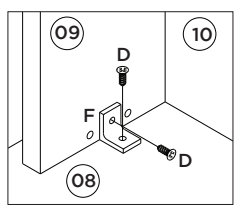
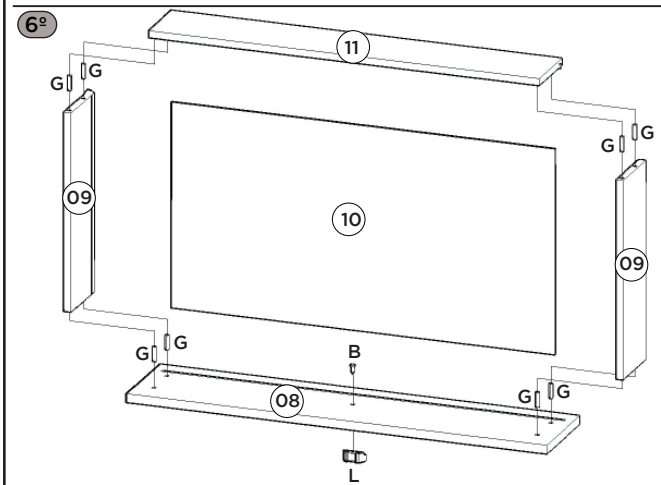
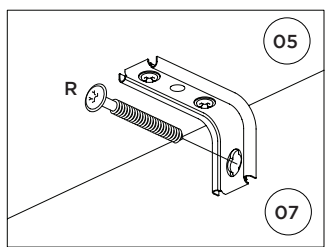
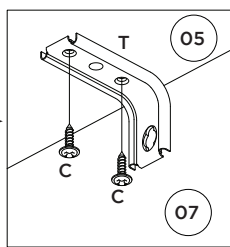

Utilize o sachê de cola (P) nas cavilhas (G) e nos frisos das gavetas.

Utilice pegamento sobre (P) en los pernos (G) y los cajones de los granos.

Use the glue sachet (P) on the pegs (G) and on the drawer friezes.

