

INSTRUÇÕES DE MONTAGEM

INSTRUCCIONES DE MONTAJE ASSEMBLY INSTRUCTIONS

Guarda Roupa Infantil Bolinha de Sabão

IE59-10 Branco
IE59-116 Cristal/Branco

Requisitos para montagem
Requisitor para la montaje
Assembly Requirements

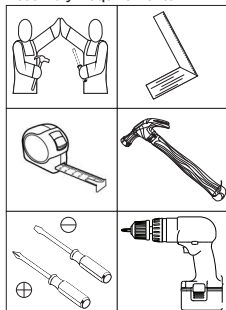

Imagens meramente ilustrativas
Imágenes meramente ilustrativas
Images for illustration only

AVISO

Para limpeza de seu móvel, use uma flanela seca ou umedecida, e não utilize produtos químicos que possam danificar seu produto.

SISTEMA DE MONTAGEM

O sistema de montagem dos produtos, funciona de acordo com a ordem crescente dos números indicados no desenho. Ex: 01, 02, 03, 04... até a conclusão da montagem.

ADVERTENCIA

Para limpieza de su móvil, use una flanela seca o húmeda, y no utilice productos químicos que puedan dañar su producto.

SISTEMA DE MONTAJE

El sistema de montaje de los productos funciona de acuerdo con el orden creciente de los números indicados en el dibujo. Ej.: 01, 02, 03, 04... hasta la conclusión del montaje.

NOTICE

To clean your furniture, use a dry or wet cloth, and do not use chemicals that may damage your product.

ASSEMBLY SYSTEM

The products' assembly system works according to the increasing order of the indicated numbers. For example: 01, 02, 03, 04 ... to the end of the assembly.

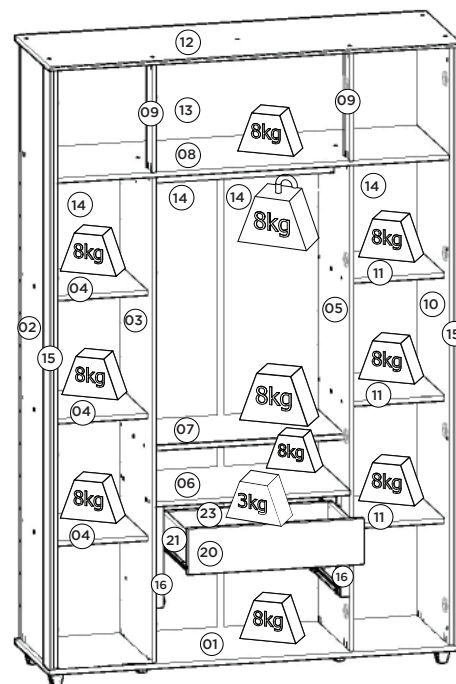
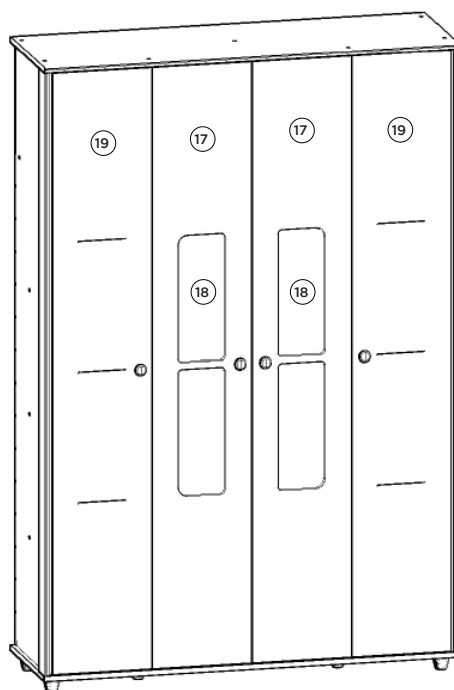

Pesos máximos recomendados com carga distribuída
Peso máximo recomendado con la carga distribuída
Recommended maximum weights with evenly distributed.

Lista de Peças | Lista de piezas | List of parts

Item	Caixa Caja Box	Qtd Ctd Qty	Descrição Descripción Description	Medidas (mm) Dimensions (mm) Size (measurements) (mm)
01	2/2	01	Base Base Base	1320x427x15
02	1/2	01	Lateral esquerda Lateral izquierda Left side	1920x410x15
03	2/2	01	Divisão esquerda División Izquierda Left division	1555x410x12
04=11	2/2	03	Prateleira Estante Shelf	350x305x15
05	2/2	01	Divisão direita División derecha Right division	1555x410x12
06	2/2	01	Tampo das Gavetas Cubre los cajones Drawer Top	624x410x15
07	2/2	01	Prateleira Central Estanteria Central Central Shelf	624x350x15
08	2/2	01	Chão do Maleiro Suelo de rack de equipaje Luggage rack floor	1258x410x15
09	2/2	02	Ripa do Maleiro Listón de bastidor de equipaje Luggage rack batten	350x65x12
10	1/2	01	Lateral direita Lateral derecha Right side	1920x410x15
11=04	2/2	03	Prateleira Estante Shelf	350x305x15
12	2/2	01	Tampo Tapa Top	1320x438x15
13	1/2	01	Fundo Superior Fondo Superior Top Bottom	1282x372x3
14	1/2	04	Fundo Fondo Bottom	1577x318x3
15	1/2	02	Moldura Lateral Marco lateral Lateral Frame	1920x410x15
16	2/2	02	Ripa lateral Lado ripa Side lath	326x54x25
17	1/2	02	Porta Central Puerta Central Central Door	1913x315x15
18	2/2	02	Vidro Vidrio Glass	870x190x3
19	1/2	02	Porta lateral Puerta lateral Side door	1913x315x15
20	2/2	02	Frente de gaveta Frente de cajón Front of drawer	350x110x15
21	2/2	04	Lado de gaveta Lado del cajón Side of drawer	350x110x15
22	1/2	02	Fundo de gaveta recortado Fondo de cajón recortado Drawer bottom trimmed	530x361x3
23	2/2	02	Ripa de trás Malla detrás Rear lath	549x110x15

Ferragens | Herrajes | Hardware

A Parafuso 5,0x50mm FLA. Tornillo 5,0x50mm FLA. Screw 5,0x50mm FLA.	B Parafuso 4,0x35mm CHT. Tornillo 4,0x35mm CHT. Screw 4,0x35mm CHT.	C Giz de correção Tiza de corrección Chalk of correction	D Parafuso 4,0x25mm CHT. Tornillo 4,0x25mm CHT. Screw 4,0x25mm CHT.	E Parafuso 3,5x40mm CHT. Tornillo 3,5x40mm CHT. Screw 3,5x40mm CHT.	F Parafuso 3,5x25mm FLA. Tornillo 3,5x25mm FLA. Screw 3,5x25mm FLA.	G Parafuso 3,5x12mm FLA. Tornillo 3,5x12mm FLA. Screw 3,5x12mm FLA.	H Parafuso 3,5x12mm CHT. Tornillo 3,5x12mm CHT. Screw 3,5x12mm CHT.	I Parafuso 3,0x30mm CHT. Tornillo 3,0x30mm CHT. Screw 3,0x30mm CHT.	J Parafuso 3,0x16mm CHT. Tornillo 3,0x16mm CHT. Screw 3,0x16mm CHT.	K Cavilha 5x25mm Cinta 5x25mm Dowel 5x25mm	L Prego 10x10mm Clavo 10x10mm Nail 10x10mm	M Fixador de fundos Fijador de fondos Bottom fixer	N Suporte fixação de vidro Soporte de fijación de cristal Glass fixing bracket	O Cantoneira plástica Cantenera plástica Plastic angle brackets	P Cantoneira suporte triangular Cantenera soporte triangular Triangle support angle	Q Calço metal 5mm Calzado metálico 5mm 5 mm metal shim	R Dobradiça metal 26mm Bisagra de metal 26mm 26 mm metal hinge	S Corredoiça metal 350mm Corredora de metal 350mm Sliding metal 350mm	T Pé Cônico AL12 Pie Cónico AL12 Conical Foot AL12	U Puxador Catar Branco Tirador Catar Blanco Catar White Handle	V Suporte cabideiro Soporte de percha Coat hanger support	W Cabideiro Alum. 616mm Alu 616mm percha Alu coat hanger 616mm	X Perfil "I" 1568mm Perfil "I" 1568mm Profile "I" 1568mm	Y Buchsa plástica 8mm Bucha de plástico 8mm 8mm plastic bushing	Z Suporte de fixação Soporte de fijación Mounting bracket	AA Distanciador de corredeira Distanciador de deslizamiento Sliding spacer	AB Sachê de cola Bolsa de pegamento Glue bag	AC Adesivo tapa parafuso 10mm Adhesivo tapón de tornillo 10mm Bolt cover adhesive 10mm	AD Etiqueta resinada Henn Etiqueta resinada Henn Henn resin label
---	---	--	---	---	---	---	---	---	---	--	--	--	--	---	---	--	--	---	--	--	---	--	--	---	---	--	--	--	---

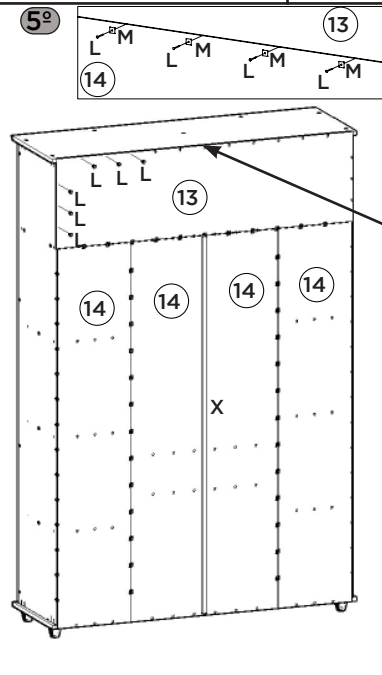
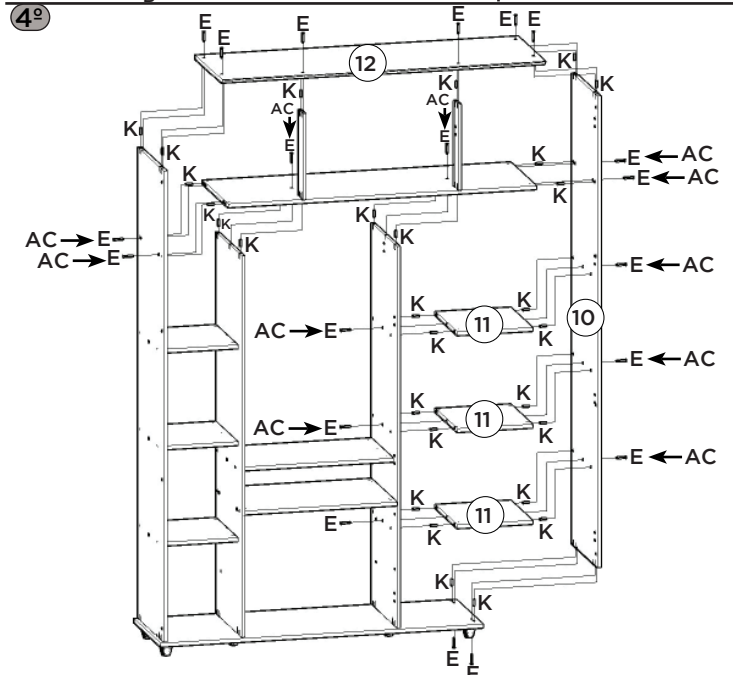
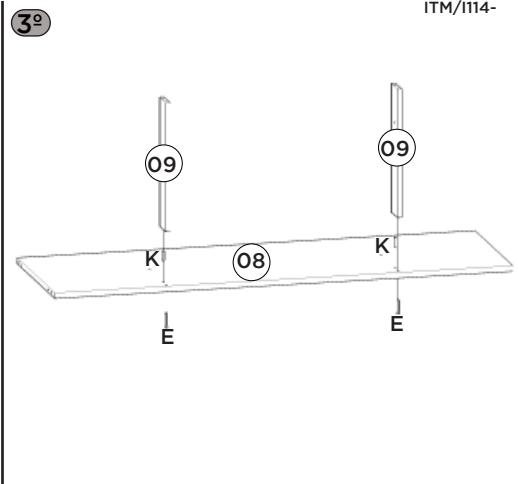
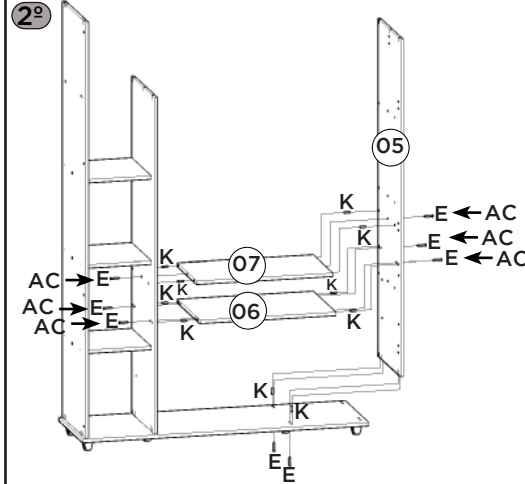
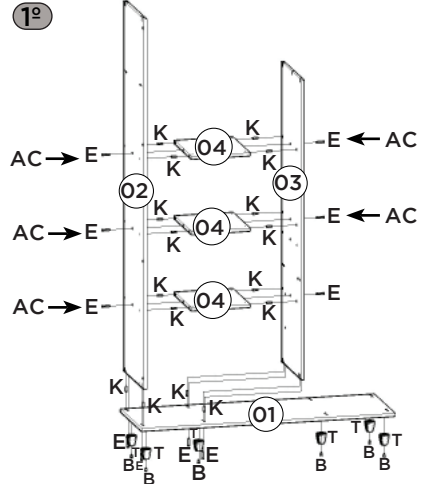

Imprescindível a fixação do produto na parede, a não colocação destas ferragens para fixação (A, G, Y e Z), poderá permitir que o produto vire, causando acidente.

Es imprescindible la fijación del producto en la pared, la no colocación de estos herrajes para fijación (A, G, Y e Z), podrá permitir que el El producto se vuelva, causando accidente.

Indispensable to fix the product on the wall, not the placement of these attachment fittings (A, G, Y and Z) may allow the product to turn, causing an accident.

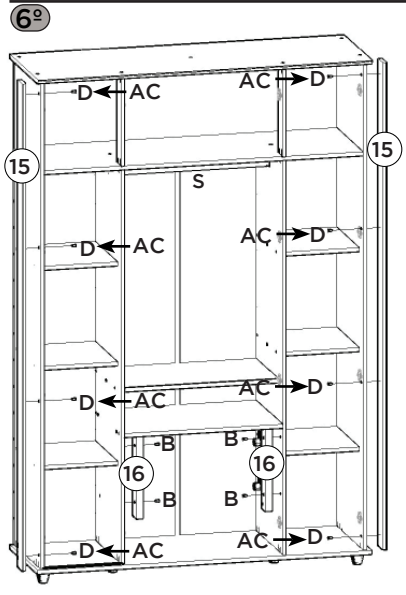
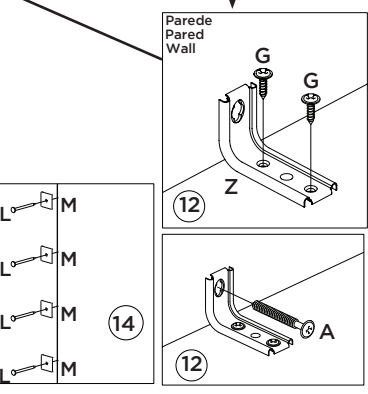

O Usinado das Molduras Laterais (15) devem ficar para o lado de dentro do móvel.

El Uso de los Marcos Laterales (15) debe quedar al lado de dentro del mueble.

The machining of the Side Frames (15) should be on the inside of the furniture.

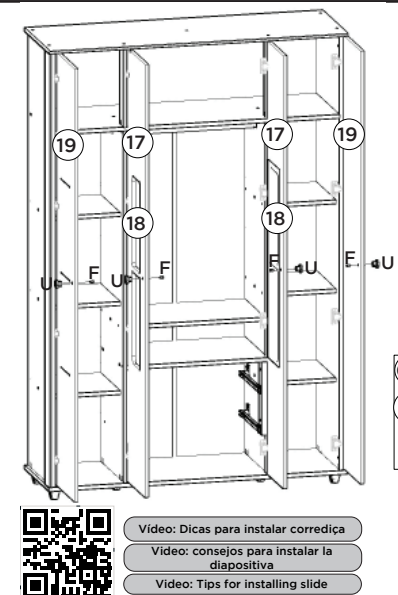

Video: Instalar e regular Dobradiças

Video: Instale y ajuste las bisagras

Video: Install and adjust hinges

Video: Dicas para instalar corredeira

Video: consejos para instalar la diapositiva

Video: Tips for installing slide

