

# ASSEMBLY INSTRUCTIONS

Ref.: 200728 - ELB0064.01 | Review 01

INSTRUCTIONS DE MONTAGE | MANUAL DE ARMADO | ESQUEMA DE MONTAGEM

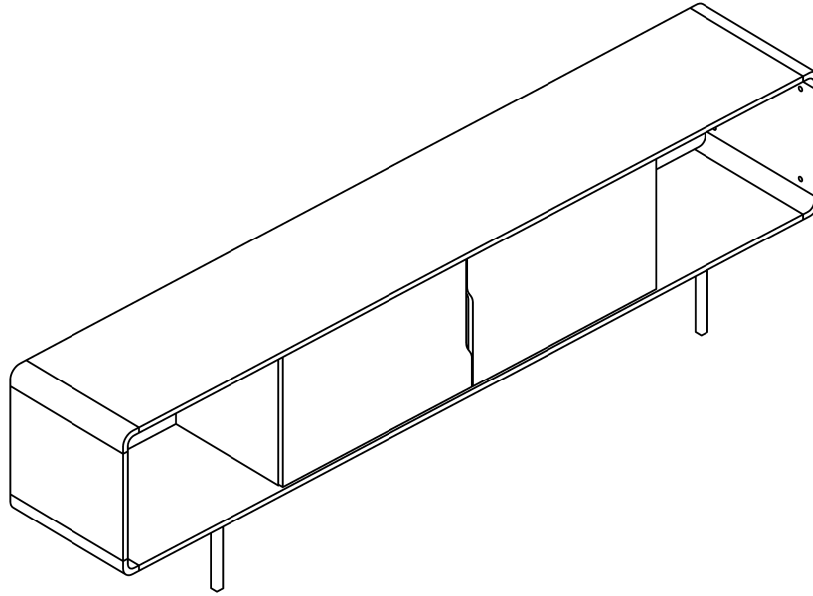

## YOU WILL NEED

TU AURAS BESOIN DE | NECESITARÁ | VOCÊ VAI PRECISAR

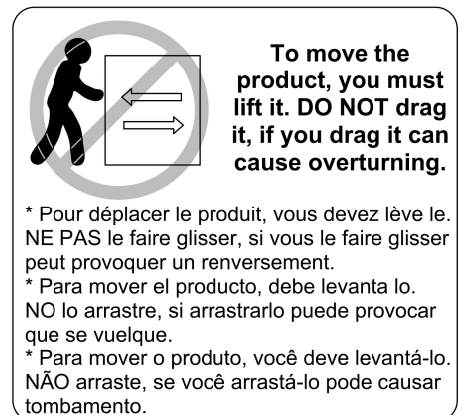
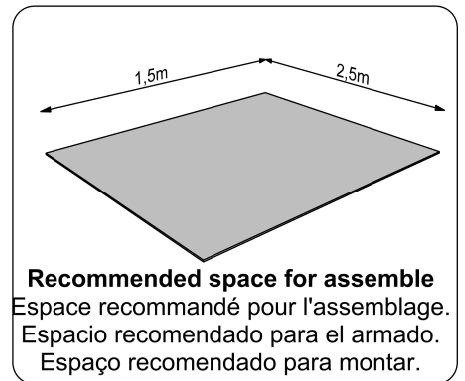
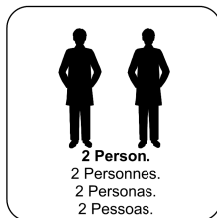
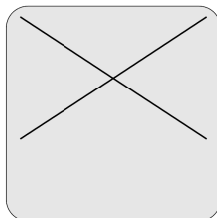
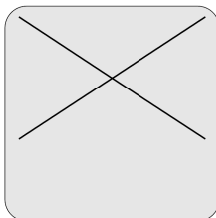
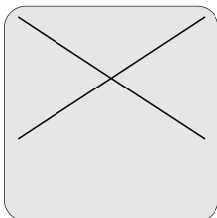
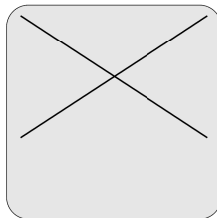
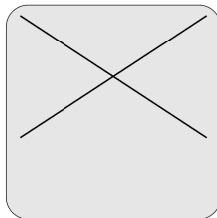
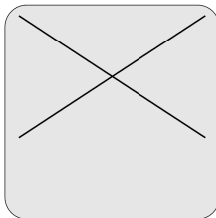
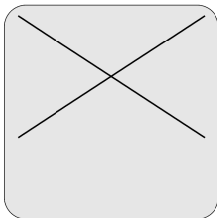
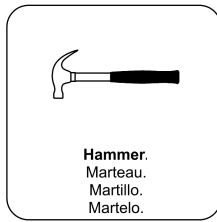
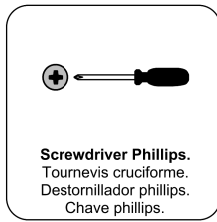
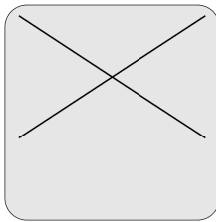
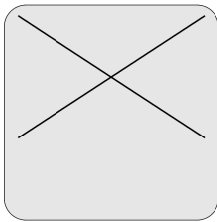







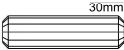

## Tools not included

Outils non inclus | Herramientas no incluidas | Ferramentas não inclusas

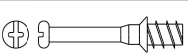
# ACCESSORIES IDENTIFICATION

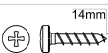
IDENTIFICATION DES ACCESSOIRES | IDENTIFICACIÓN DE ACCESORIOS  
IDENTIFICAÇÃO DOS ACESSÓRIOS

<b>A</b>		Qty./Qtd. <b>36</b>
Wooden dowel / Chevilles en bois / Taquete / Cavilha		
<b>BB</b>		Qty./Qtd. <b>2</b>
Shelf support / Support d'étagère / Soporte de estantería / Suporte prateleira		
<b>BM</b>		Qty./Qtd. <b>4</b>
Cover / Couvertres / Tapa / Tampa		
<b>C</b>		Qty./Qtd. <b>6</b>
Structural screw / Vis à tête structurelle / Tornillo estructural / Parafuso Estrutural		
<b>CH</b>		Qty./Qtd. <b>14</b>
Flat head screw / Parafuso chato / Tornillo de cabeza plana		
<b>G</b>		Qty./Qtd. <b>22</b>
Simple minifix screw / Vis minifix simple / Tornillo minifix simple / Haste Minifix Simples		
<b>H</b>		Qty./Qtd. <b>22</b>
Drum lock / Verrouillage du tambour / Tambor minifix / Tambor de Minifix		
<b>J</b>		Qty./Qtd. <b>31</b>
Nail / Ongle / Clavo / Prego		
<b>N</b>		Qty./Qtd. <b>16</b>
Pan head screw / Vis à tête bombée / Tornillo de pan / Parafuso Panela		
<b>P</b>		Qty./Qtd. <b>4</b>
Wooden dowel / Chevilles en bois / Taquete / Cavilha		
<b>Q</b>		Qty./Qtd. <b>4</b>
Metal hinge straight / Charnière métallique droite / Bisagra recta / Dobradiça Reta		

# PARTS IDENTIFICATION

IDENTIFICATION DES PIÈCES | IDENTIFICACIÓN DE PIEZAS | IDENTIFICAÇÃO DAS PEÇAS

<b>01</b>	Top Base Base Supérieure Base Superior Base Superior	Qty./Qtd. <b>01</b>
<b>02</b>	Side Côté Lateral Lateral	Qty./Qtd. <b>02</b>
<b>03</b>	Left Division Division Gauche División Izquierda Divisória Esquerda	Qty./Qtd. <b>01</b>
<b>04</b>	Right Division Division Droite División Derecha Divisória Direita	Qty./Qtd. <b>01</b>
<b>05</b>	Panel Panneau Panel Painel	Qty./Qtd. <b>02</b>
<b>06</b>	Tray Plateau Traviesa Travessa	Qty./Qtd. <b>02</b>
<b>07</b>	Bottom Base Base Inférieure Base Inferior Base Inferior	Qty./Qtd. <b>01</b>
<b>08</b>	Bottom holder Support Inférieur Titular Inferior Suporte Inferior	Qty./Qtd. <b>02</b>
<b>09</b>	Door Porte Puerta Porta	Qty./Qtd. <b>02</b>
<b>10</b>	Backboard Panneau Fondo Trasero Costa	Qty./Qtd. <b>01</b>

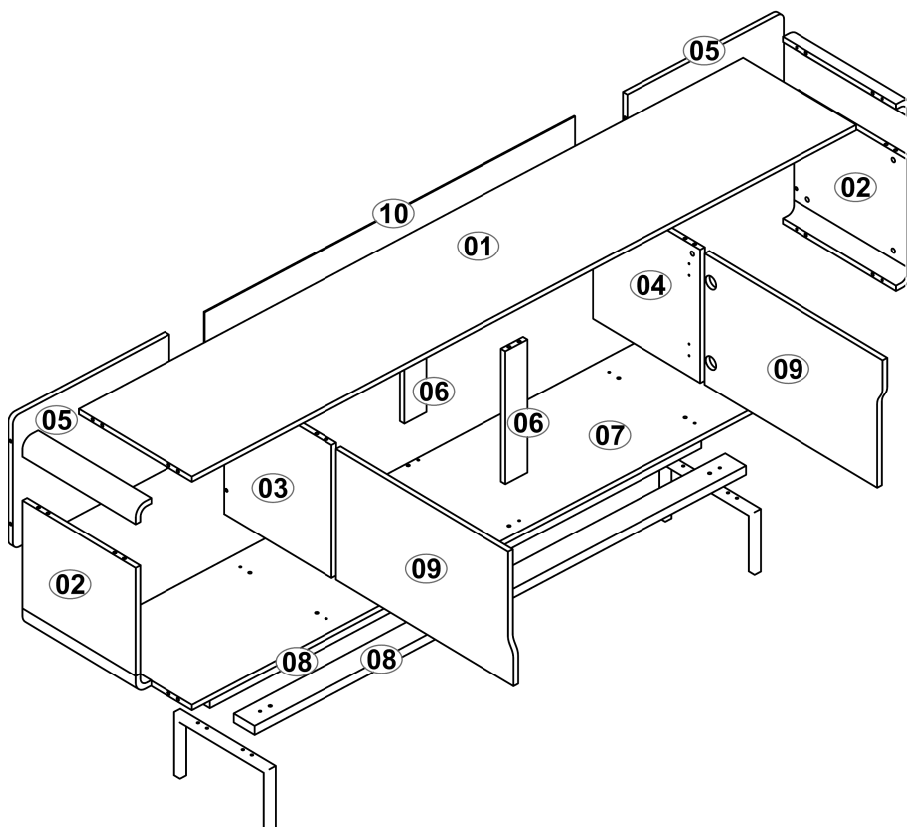

PRE-ASSEMBLY - PRÉ-ASSEMBLAGE - PRE-ARMADO  
PRÉ-MONTAGEM

01 -

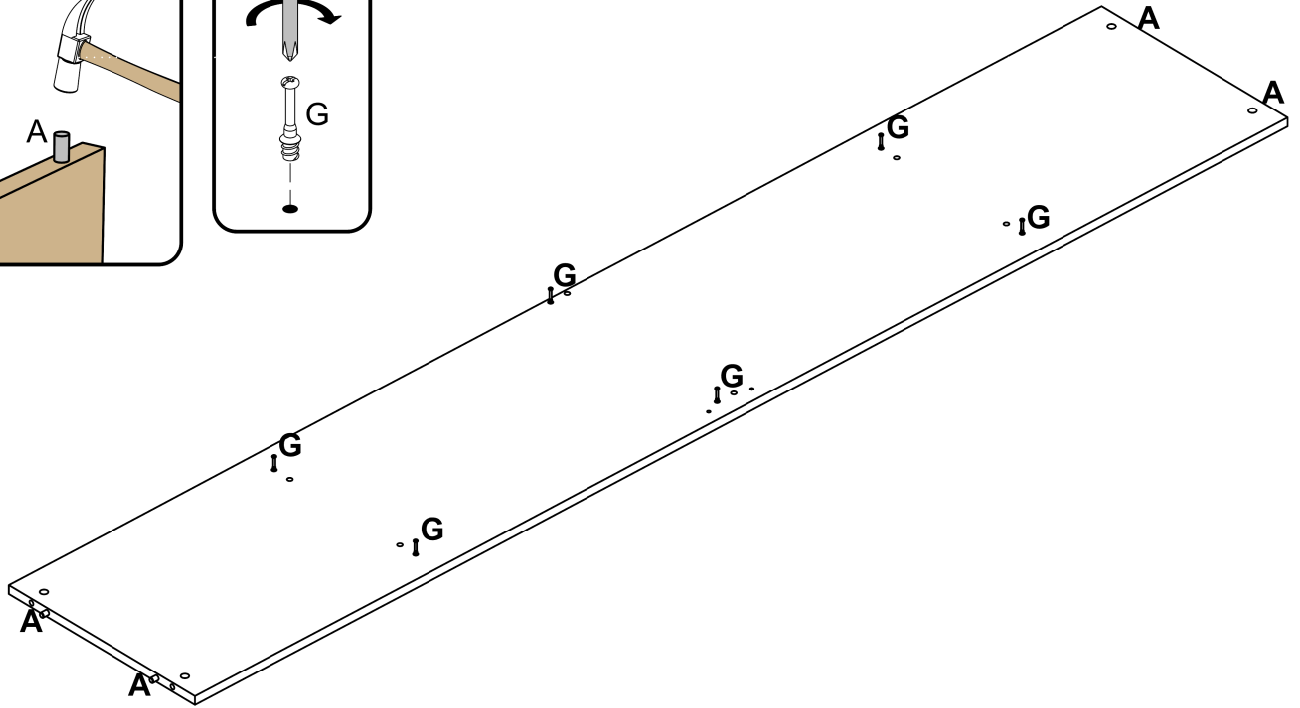
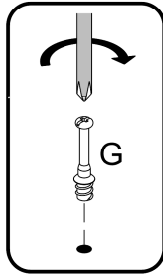
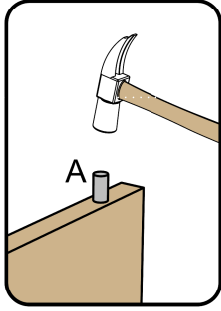

02 -

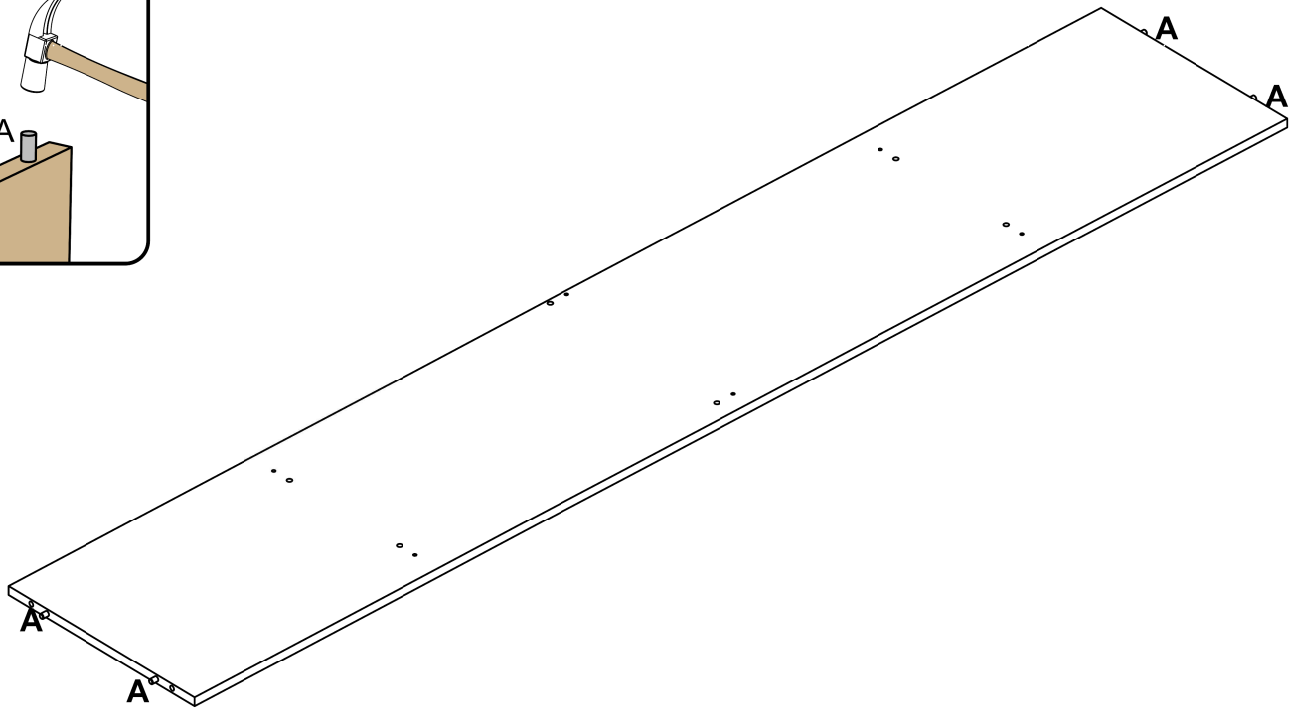
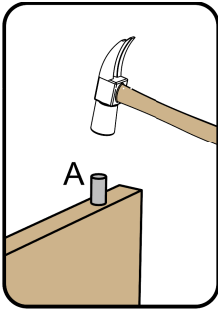

03 -

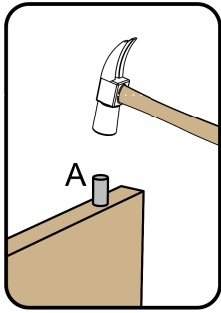

2x

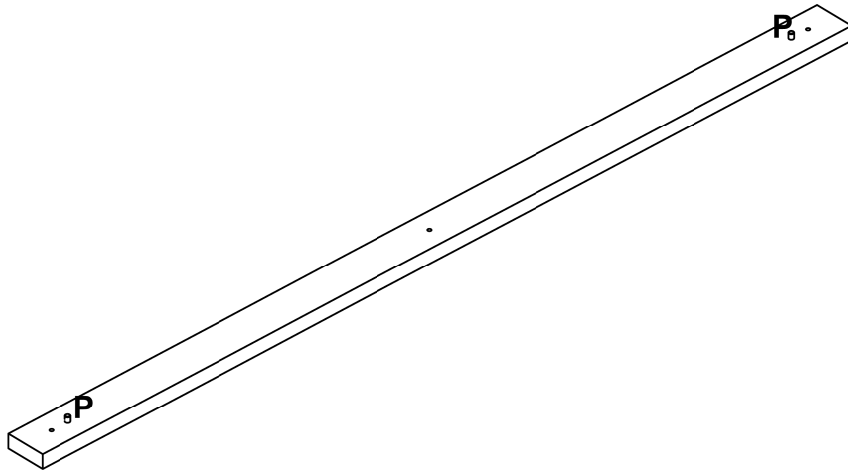

04 -

2x

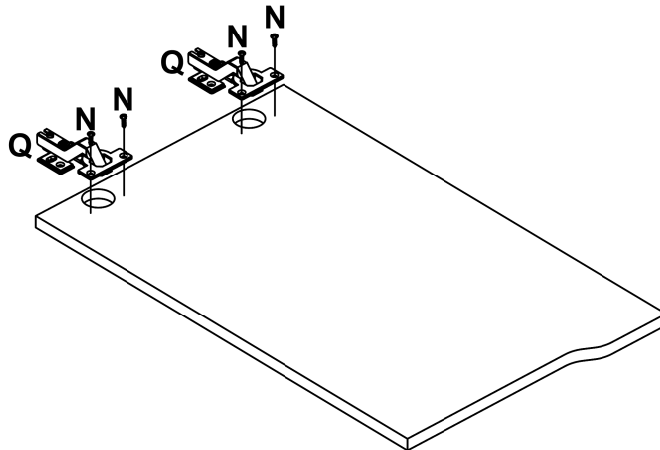

05 -

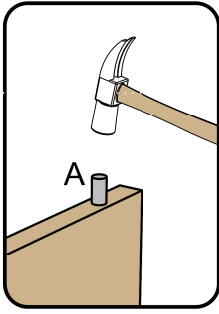

2x

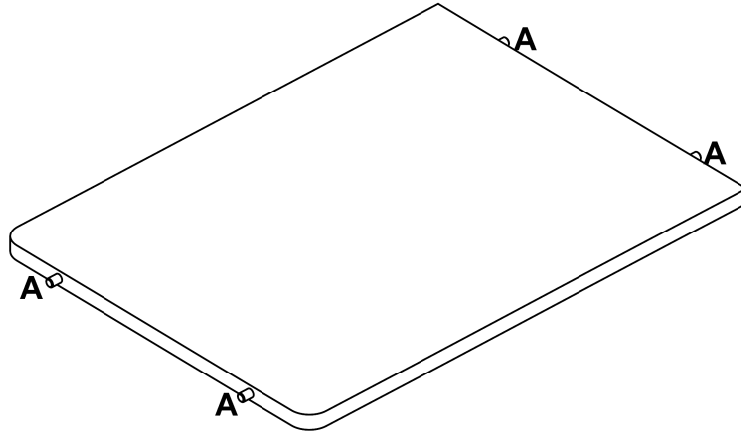

06 -

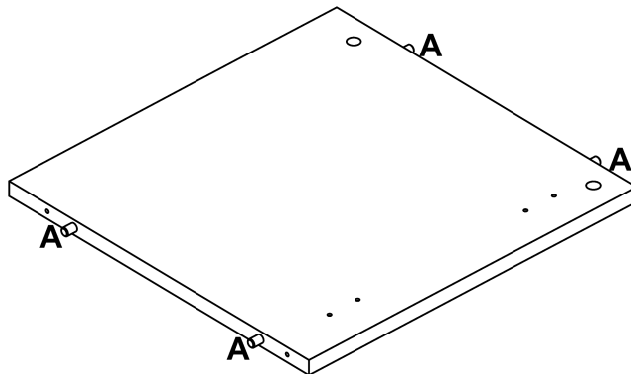
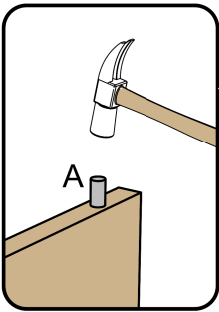

07 -

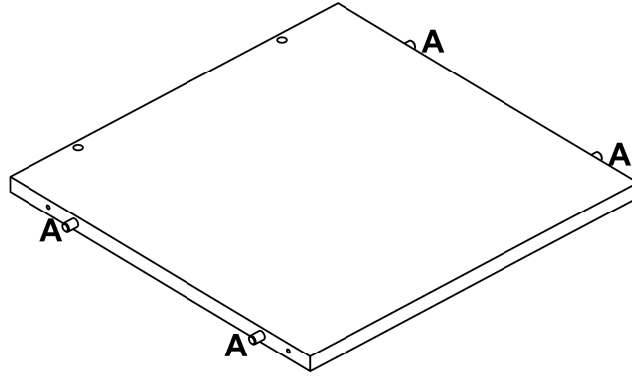
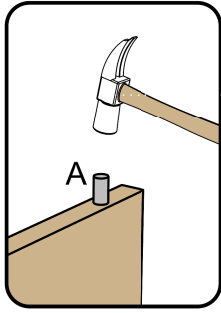

08 -

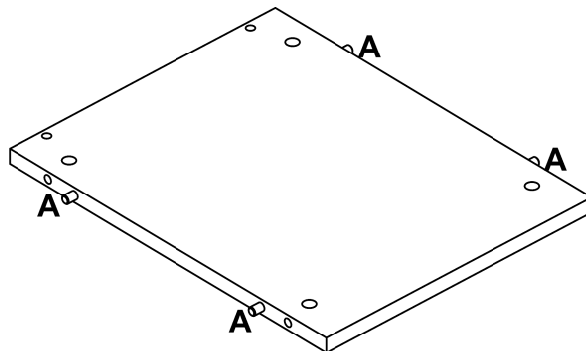
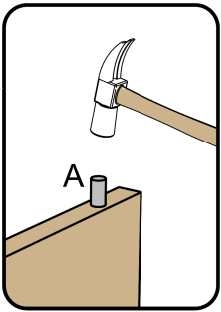

09 -

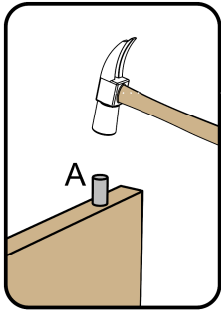

2x

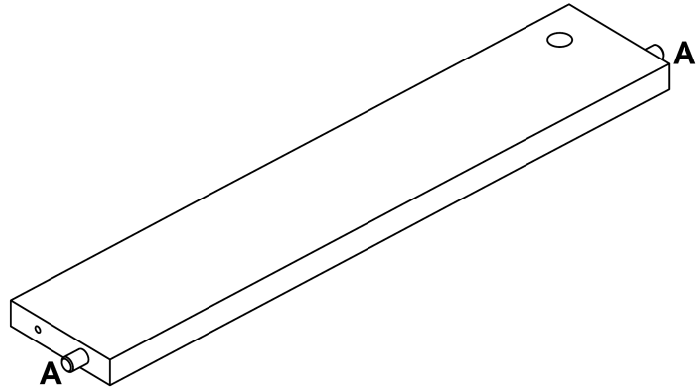

10 -

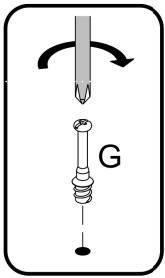

4x

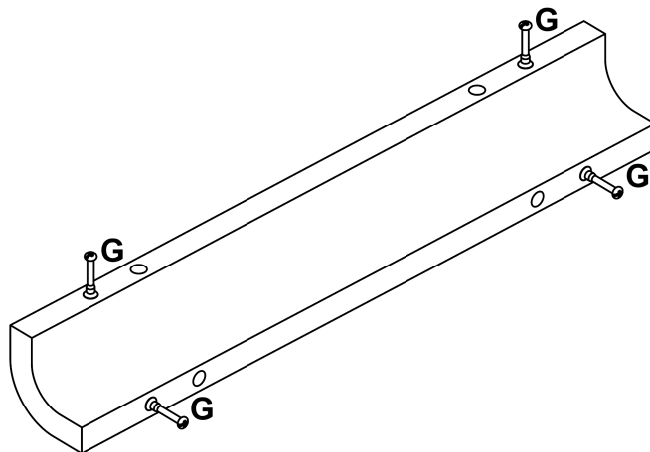

ASSEMBLY - MONTAGE - ARMADO - MONTAGEM

11 -

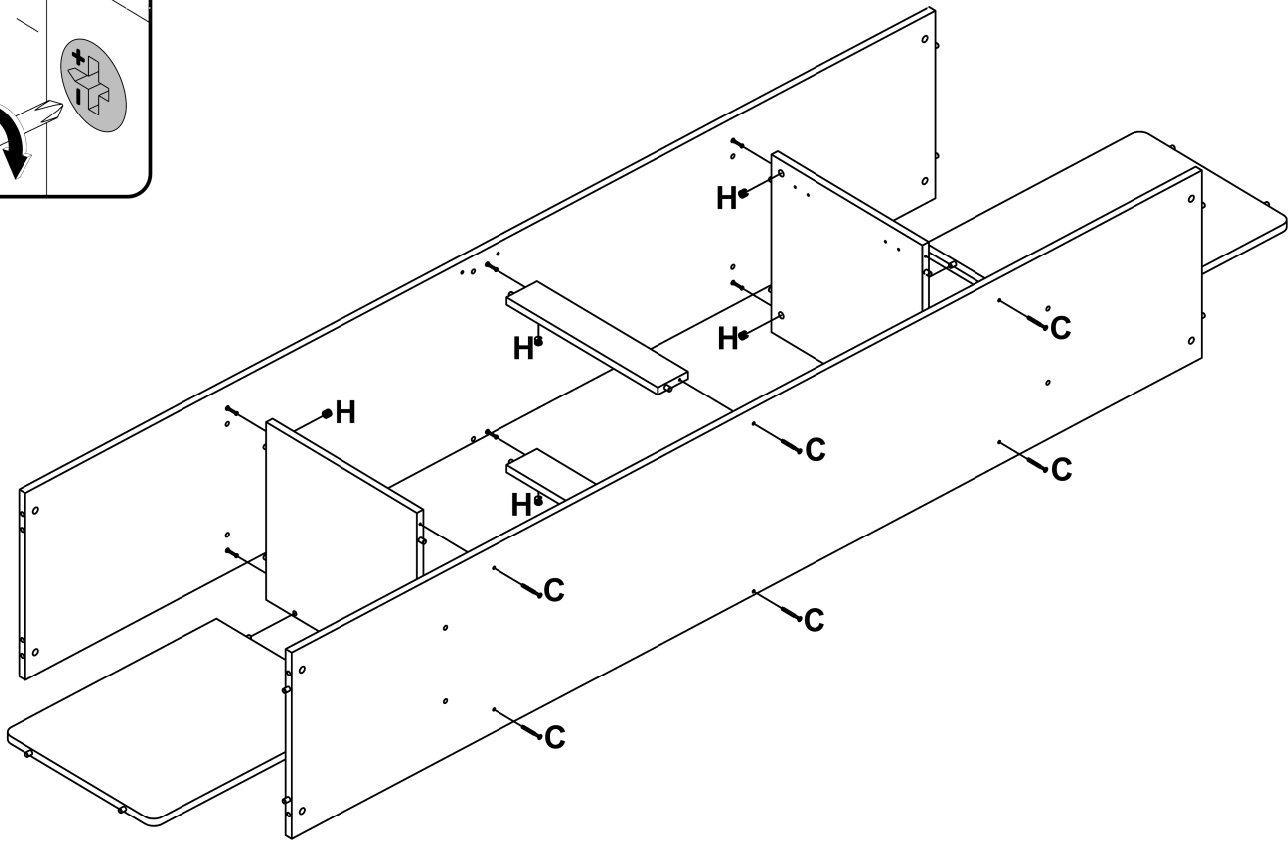
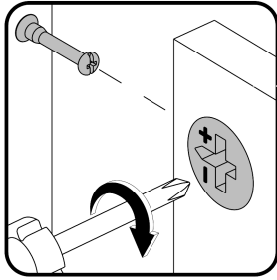

12 -

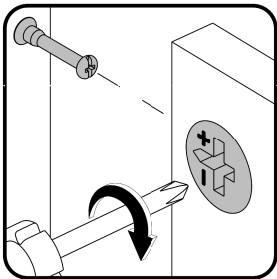

2x

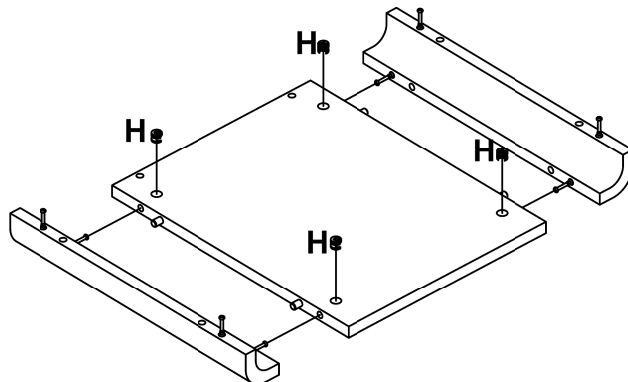

13 -

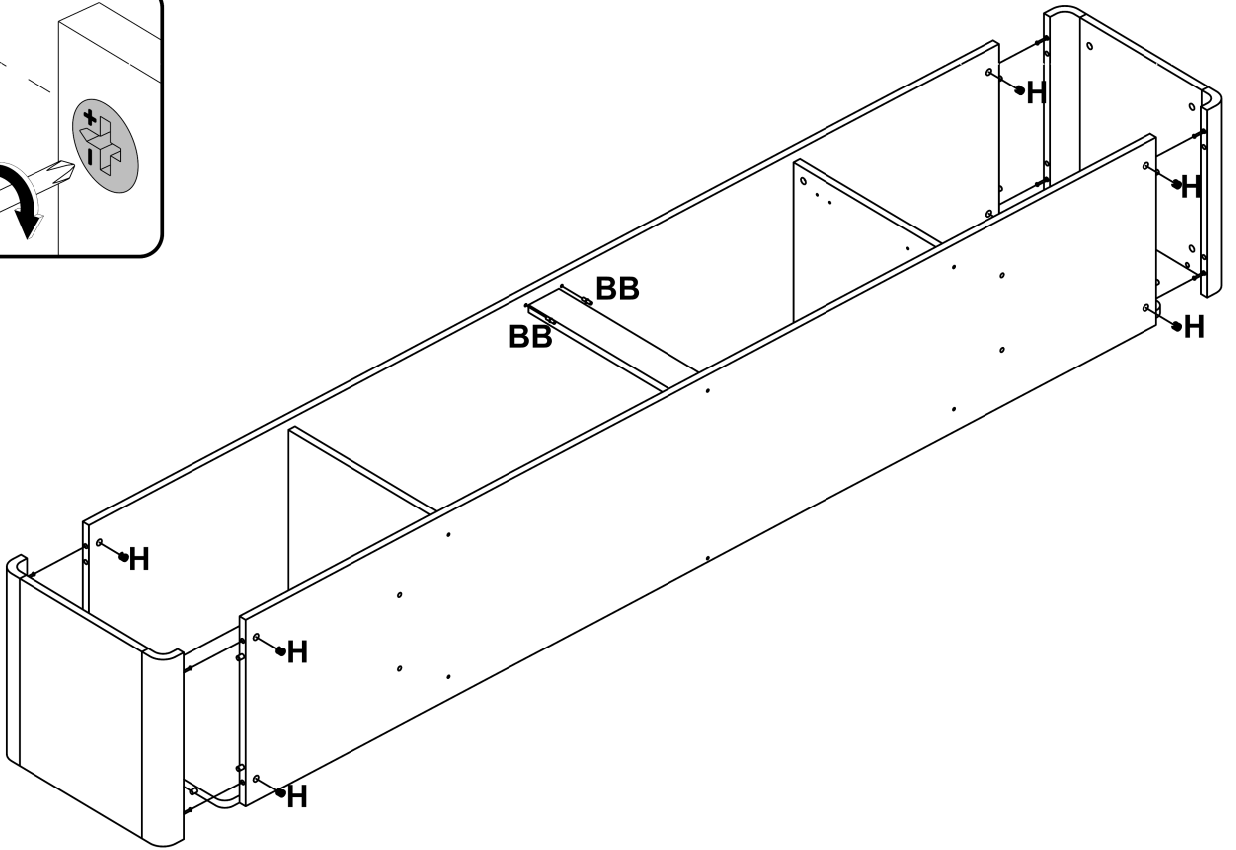
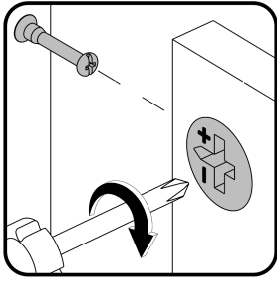

14 -

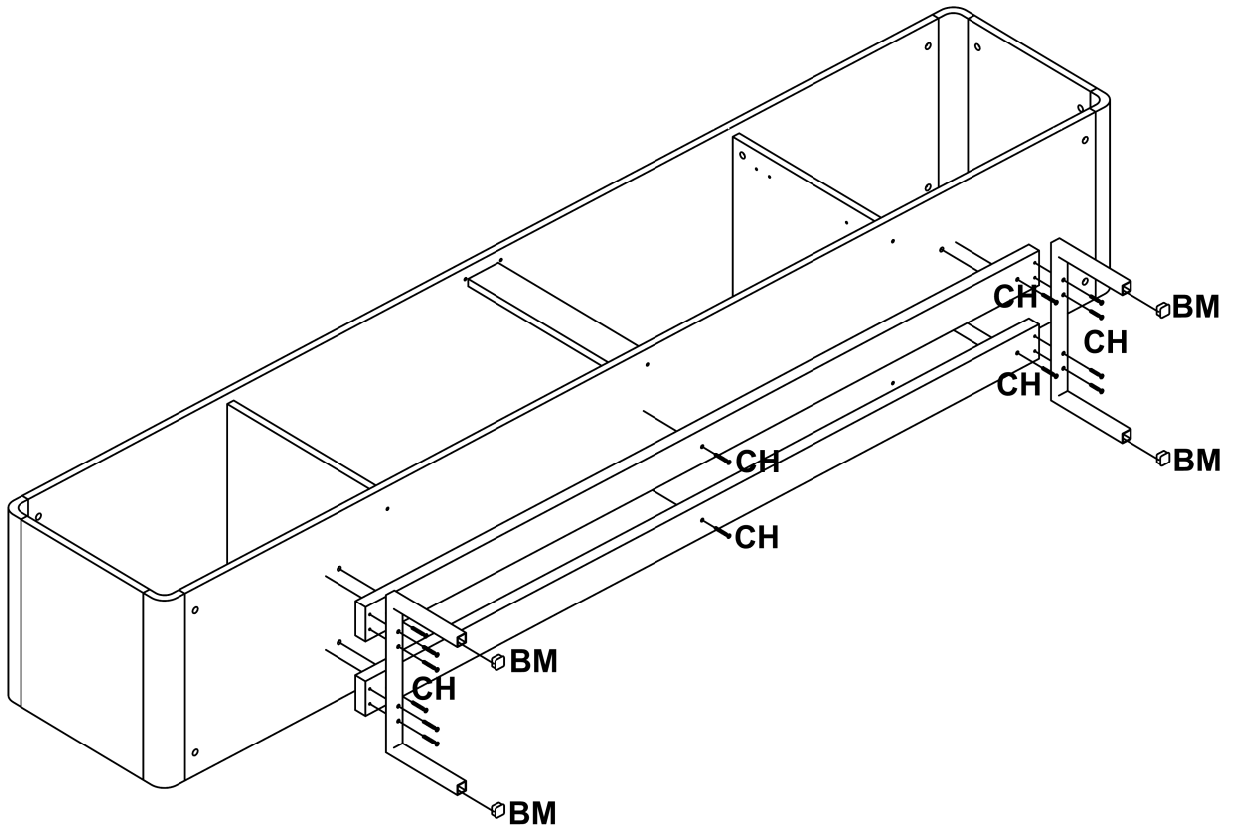

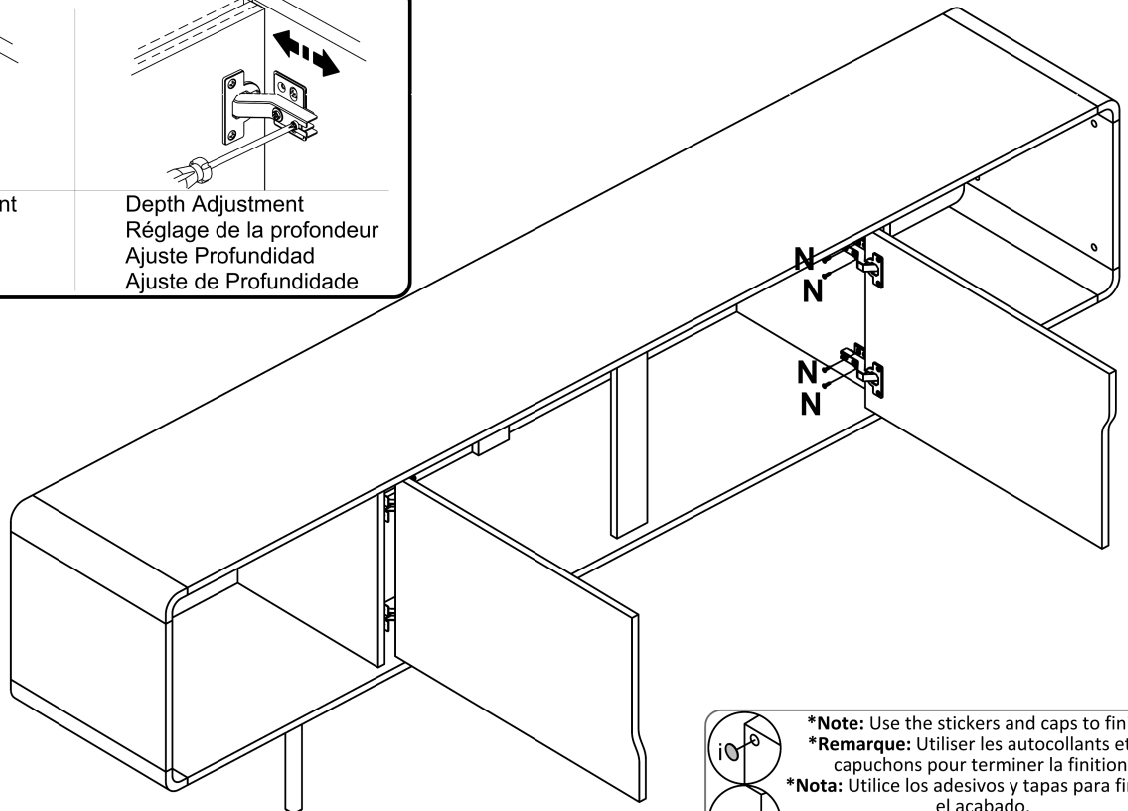
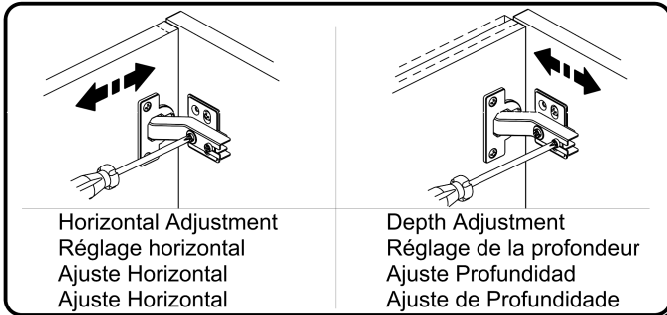
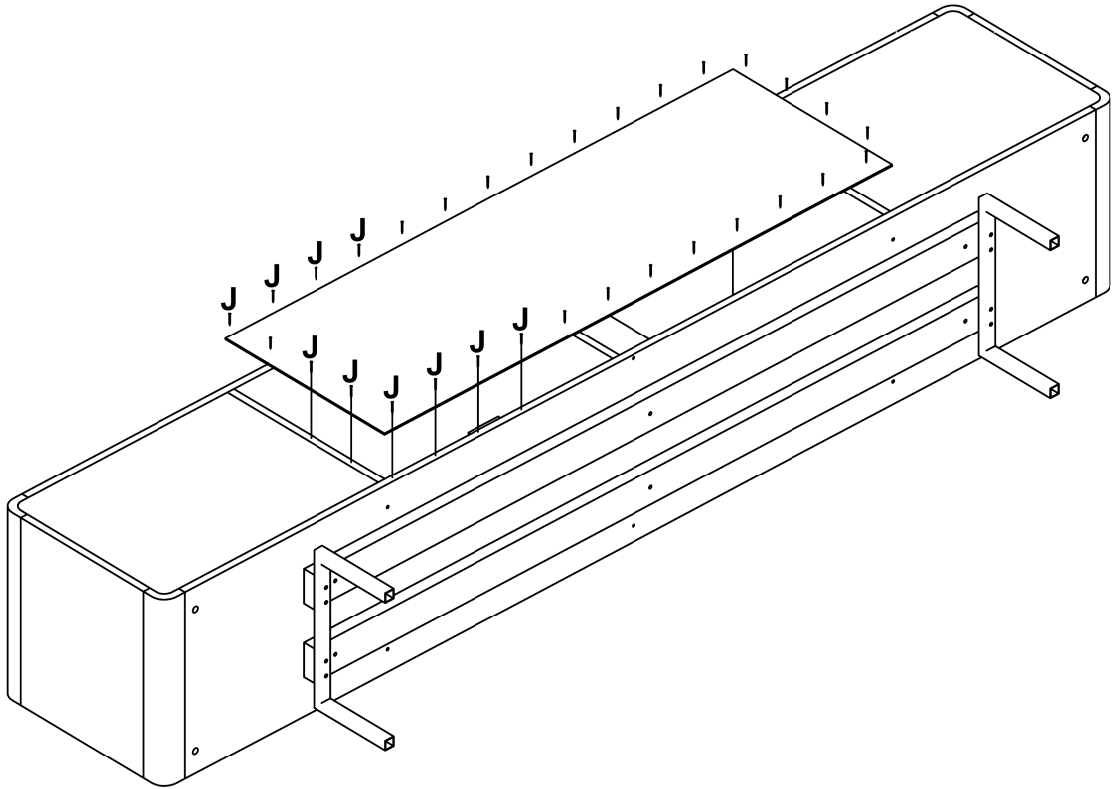

**\*Note:** Use the stickers and caps to finish.  
**\*Remarque:** Utiliser les autocollants et les capuchons pour terminer la finition.  
**\*Nota:** Utilice los adhesivos y tapas para finalizar el acabado.  
**\*Nota:** Utilize os adesivos e tampas para finalizar o acabamento.