

INSTRUÇÕES DE MONTAGEM

INSTRUCCIONES DE MONTAJE ASSEMBLY INSTRUCTIONS

Quarto Modulado Casal 5 peças Seletto

c ME06-133 Areia HP

c ME06-184 Areia HP/Jequitibá

Opção 1
Opción 1
Option 1

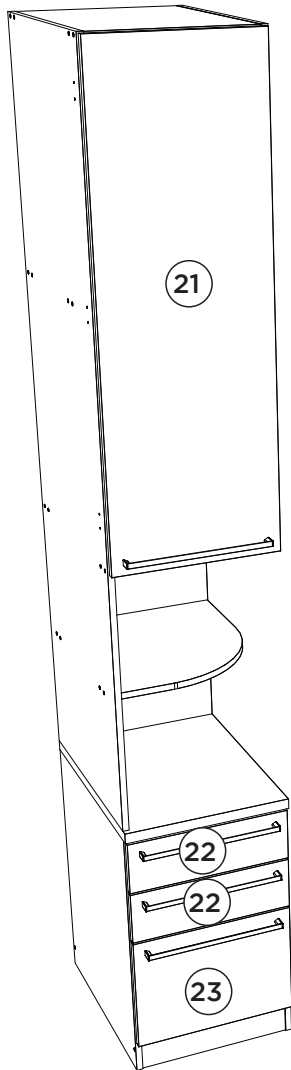

Opção 2
Opción 2
Option 2

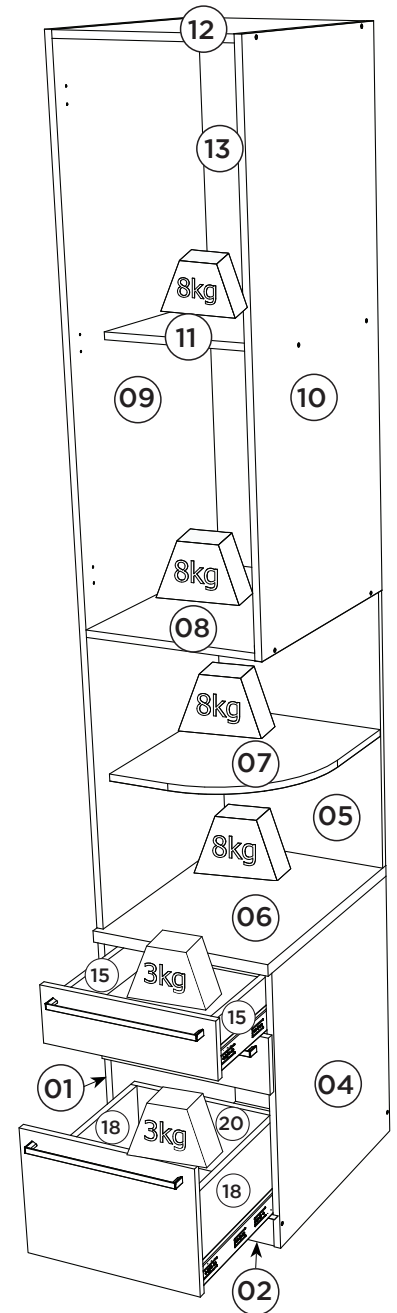
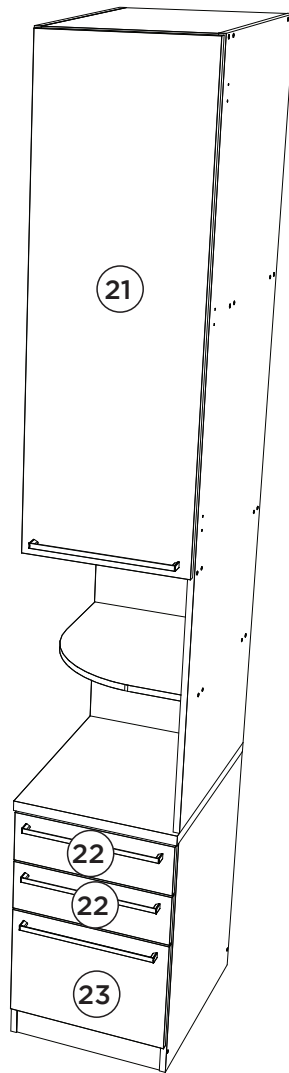

Requisitos para montagem Requisitor para la montaje Assembly Requirements

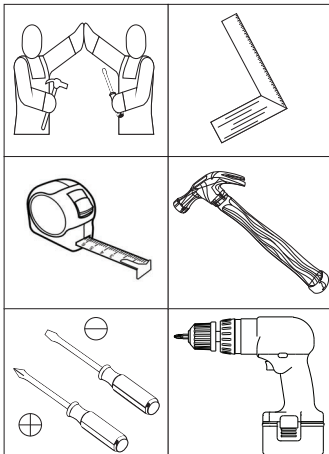

Imagens meramente ilustrativas
Imágenes meramente ilustrativas
Images for illustration only

Pesos máximos recomendados com carga distribuída Peso máximo recomendado con la carga distribuida Recommended maximum weights with evenly distributed.

AVISO

Para limpeza de seu móvel, use uma toalha seca ou umedecida, e não utilize produtos químicos que possam danificar seu produto.

SISTEMA DE MONTAGEM

O sistema de montagem dos produtos, funciona de acordo com a ordem crescente dos números indicados no desenho. Ex: 01, 02, 03, 04... até a conclusão da montagem.

ADVERTENCIA

Para limpieza de su móvil, use una franela seca o húmeda, y no utilice productos químicos que puedan dañar su producto.

SISTEMA DE MONTAJE

El sistema de montaje de los productos funciona de acuerdo con el orden creciente de los números indicados en el dibujo. Ej.: 01, 02, 03, 04... hasta la conclusión del montaje.

NOTICE

To clean your furniture, use a dry or wet cloth, and do not use chemicals that may damage your product.

ASSEMBLY SYSTEM

The products' assembly system works according to the increasing order of the indicated numbers. For example: 01, 02, 03, 04 ... to the end of the assembly.

1

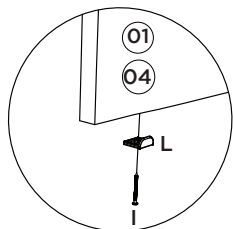
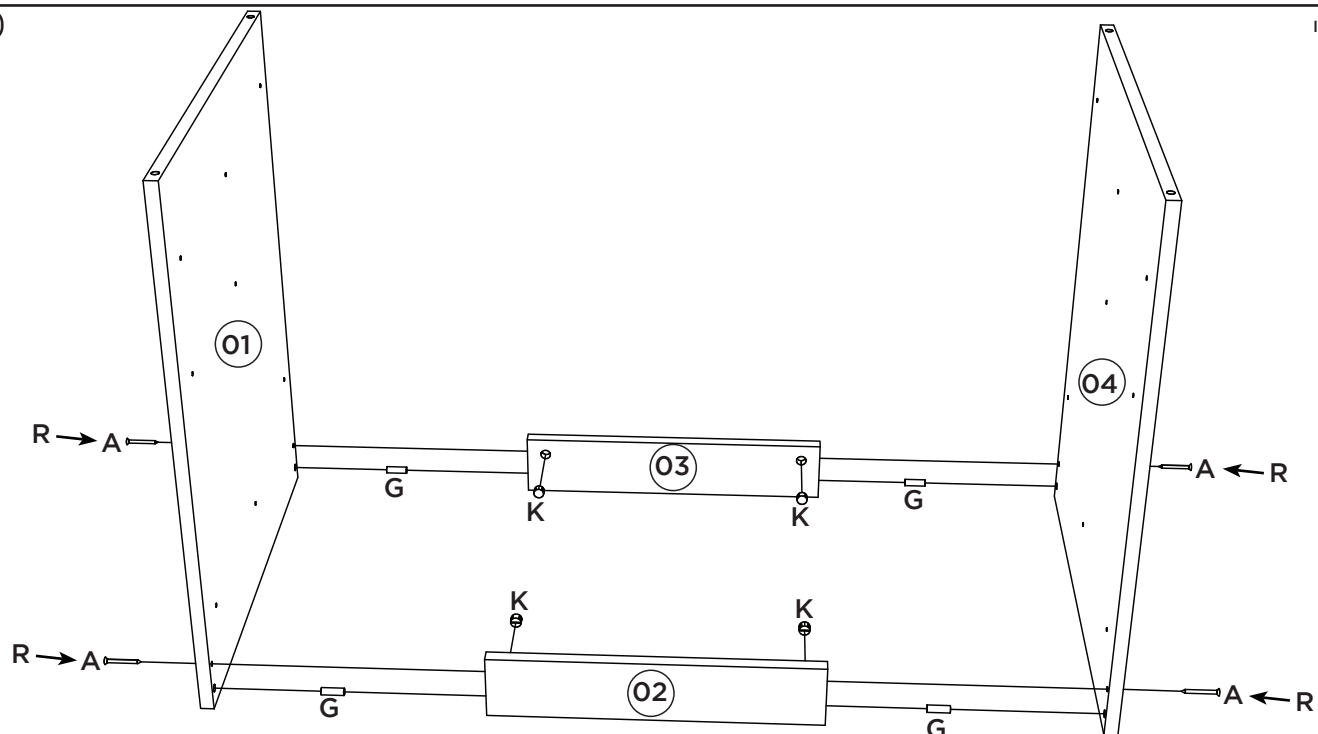

2

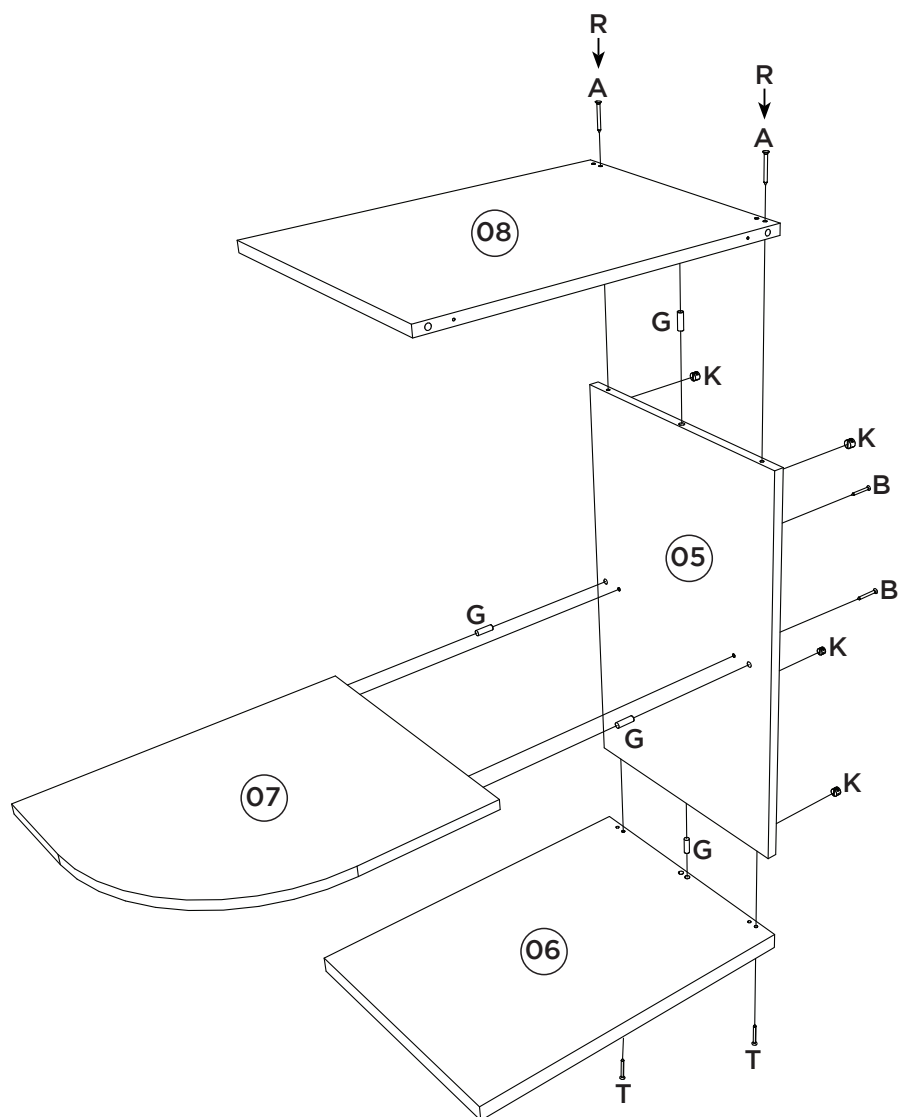

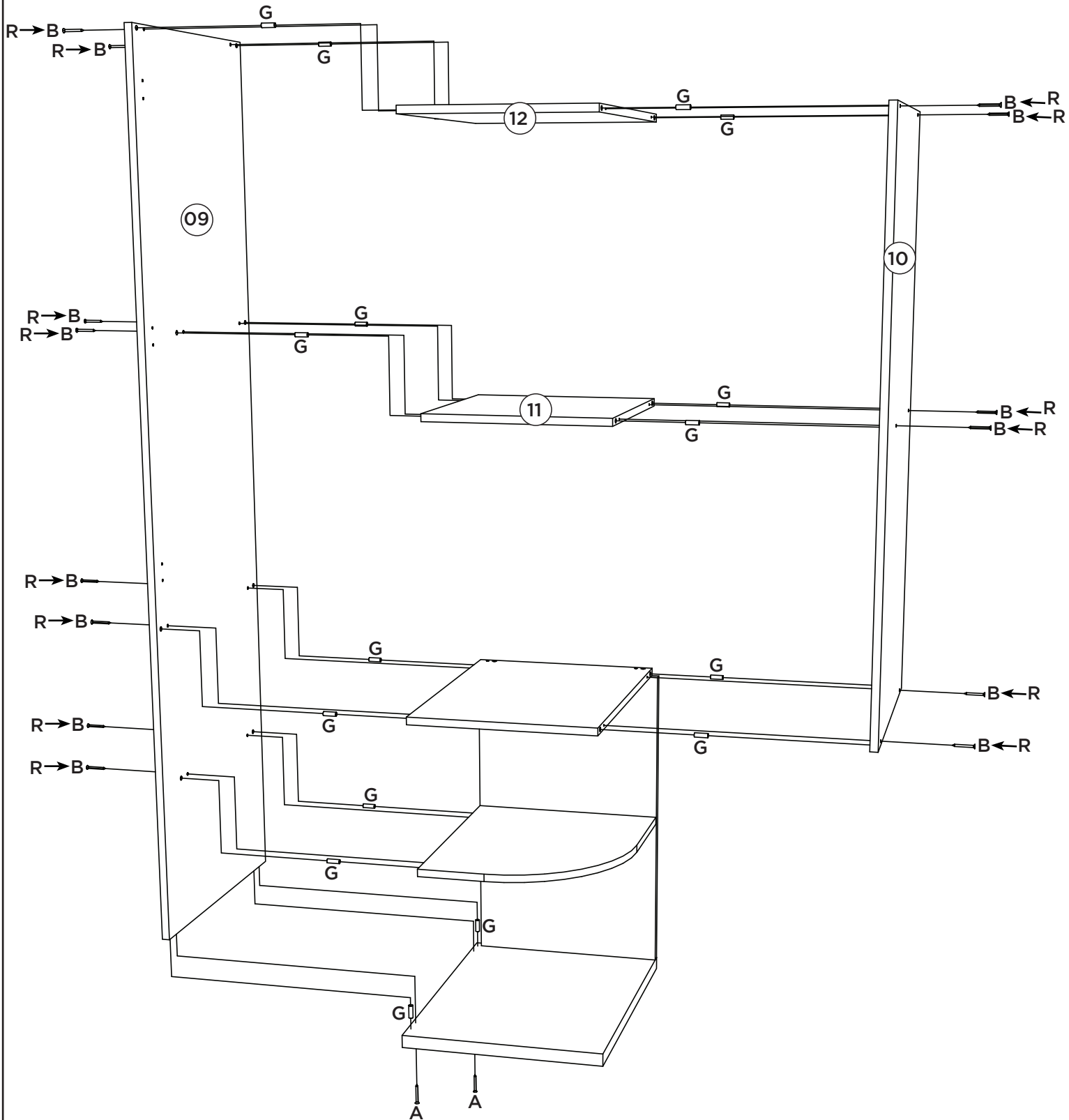

Fazer a furação passante para colocação da cavilha

Hacer la perforación pasante para colocar la clavija

Making the through hole for the pin placement

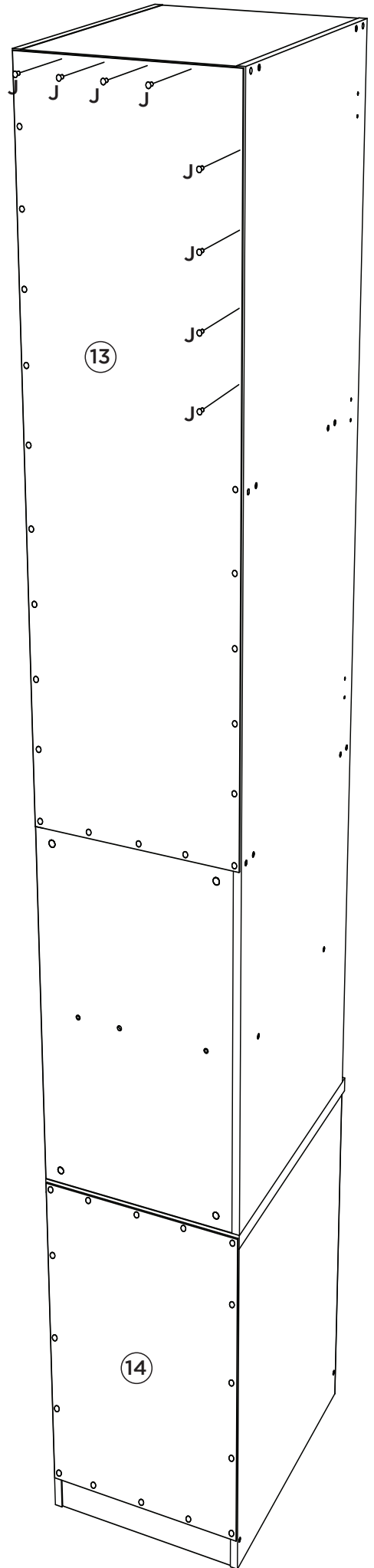
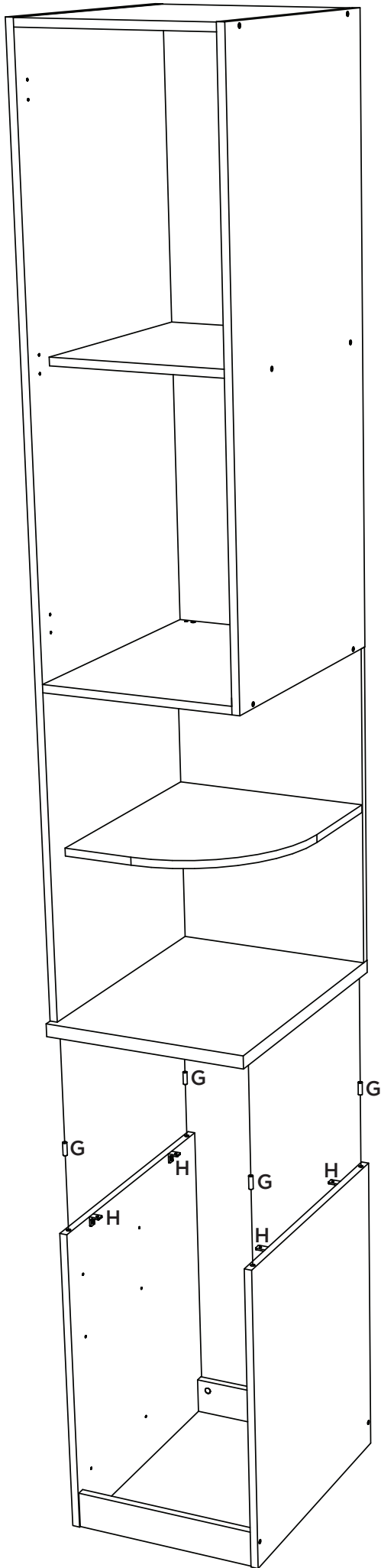

6

Observação: As ferragens que serão utilizadas na porta e gavetas, já acompanham o produto.

Nota: Los herrajes que se utilizarán en la puerta y los cajones ya están incluidos con el producto.

Note: The hardware that will be used in the door and drawers are already included with the product.

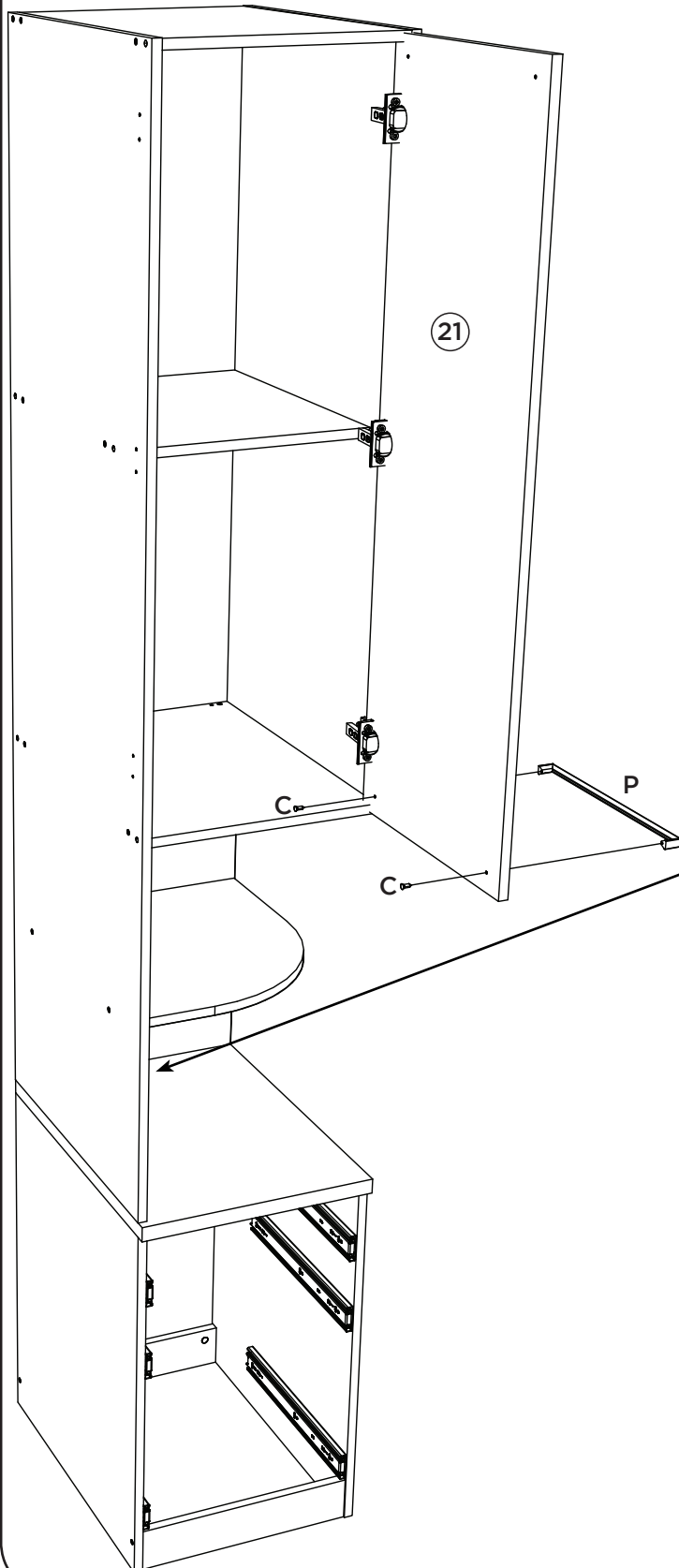
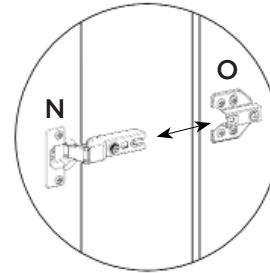
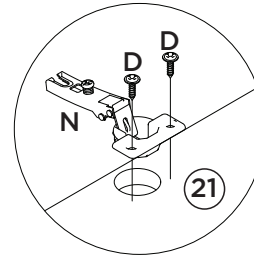
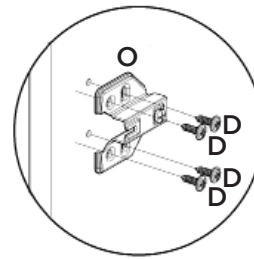

OPCIONAL: Kit Tomada Preta (01010194)
 OPTIONAL: Kit socket Black (01010194)
 OPTIONAL: Black Outlet Kit (01010194)

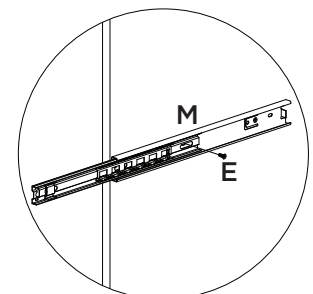
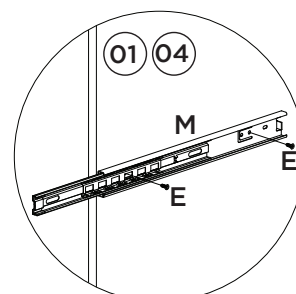
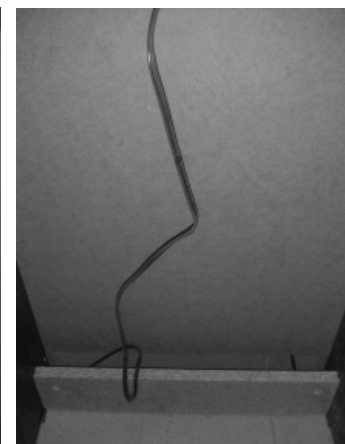
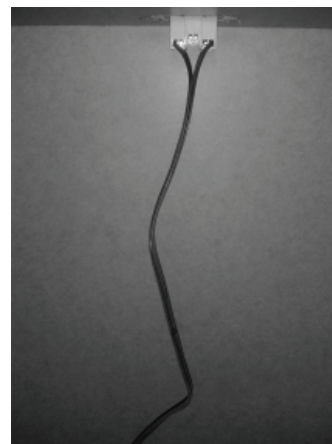

2X

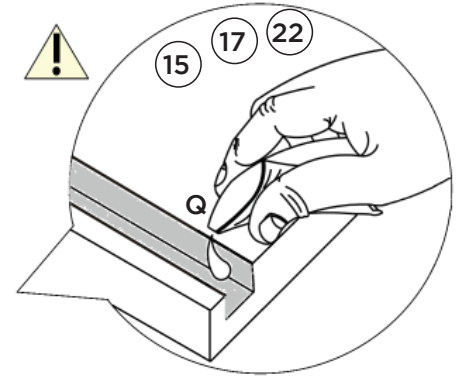
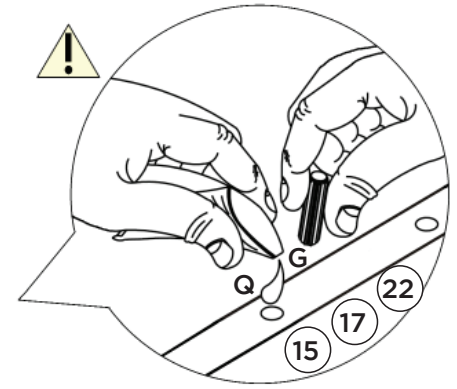
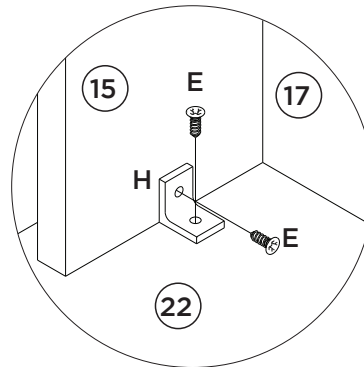
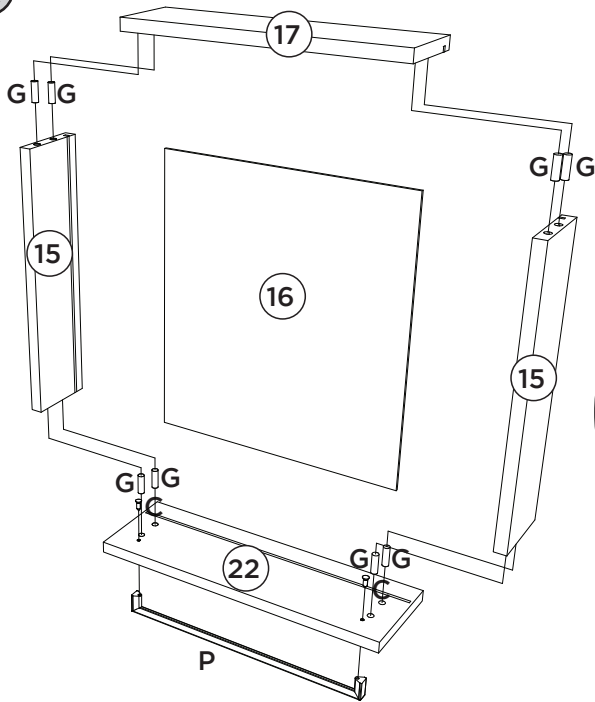

Fixar o Puxador (P) na Frente de Gaveta antes de colocar a peça (15).

Fije la Manija (P) en el Frente del Cajón antes de colocar la pieza (15).

Fix the Handle (P) on the Front of the Drawer before placing the part (15).

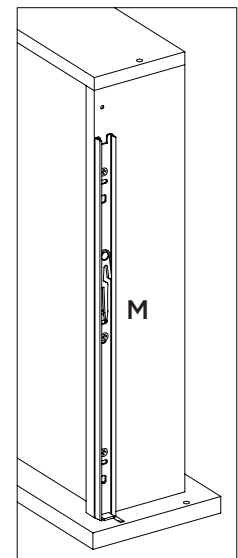

A corredeira (M) deverá ser alinhada com a parte de baixo do lado de gaveta (15)

La corredera (M) debe ser alineada con la parte de por el lado del cajón (15)

The slide (M) should be Aligned with the bottom Of the drawer side (15)

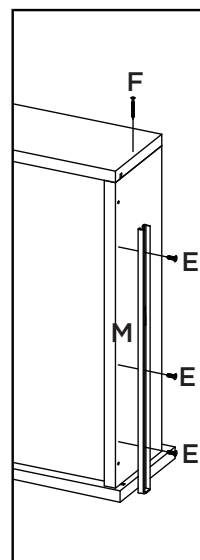
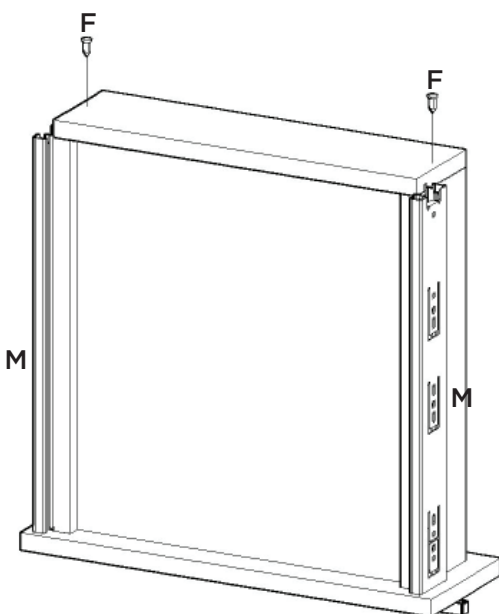

1X

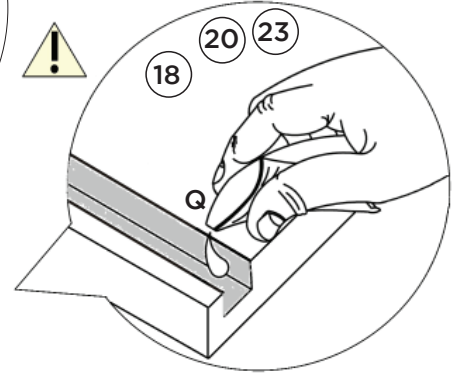
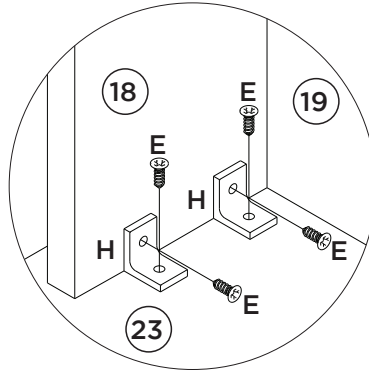
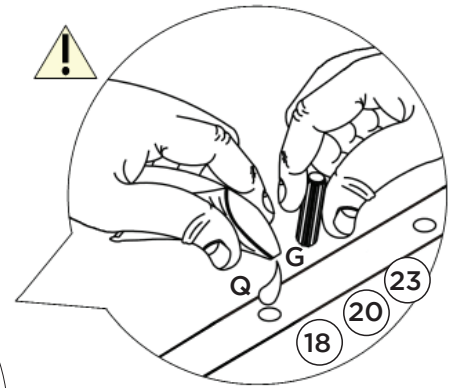
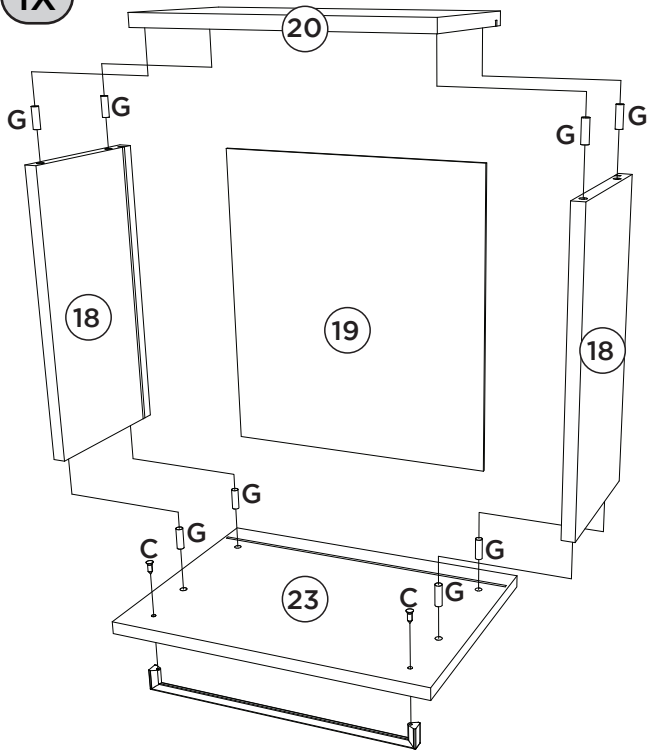

Fixar o Puxador (P) na Frente de Gaveta antes de colocar a peça (18).

Fije la Manija (P) en el Frente del Cajón antes de colocar la pieza (18).

Fix the Handle (P) on the Front of the Drawer before placing the part (18).

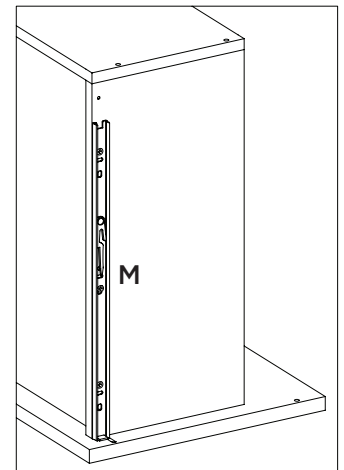

A corredeira (M) deverá ser alinhada com a parte de baixo do lado de gaveta (18)





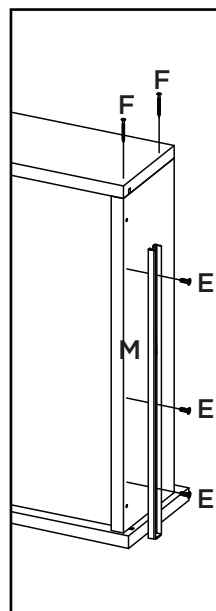
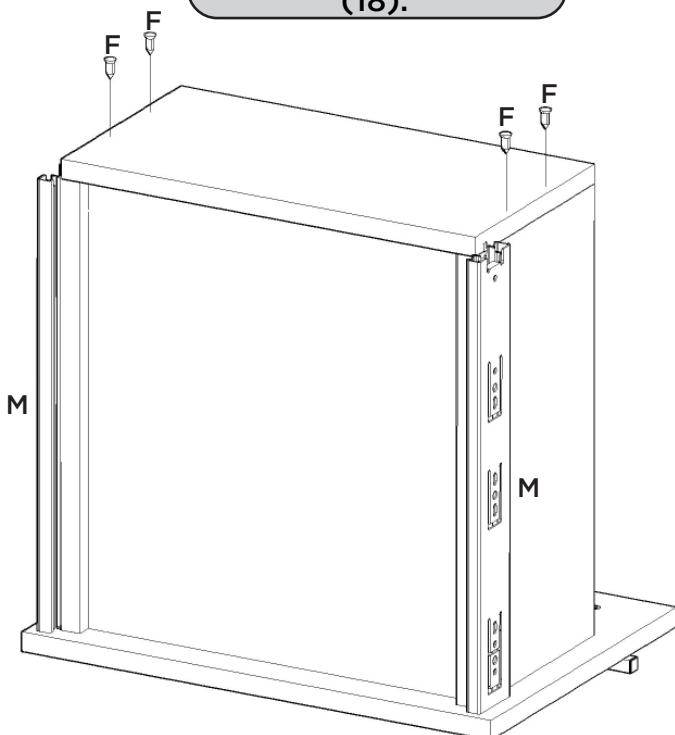







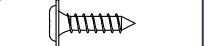

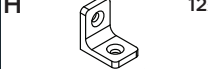

La corredera (M) debe ser alineada con la parte de por el lado del cajón (18)

The slide (M) should be Aligned with the bottom of the drawer side (18)

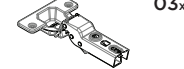

Item	Caixa Caja Box	Qty Ctd Qty	Descrição Descripción Description	Medidas (mm) Dimensions (mm) Size (measurements) (mm)
01	1/2	01	Lateral esquerda Lateral izquierda Left side	621x520x15
02	1/2	01	Rodapé frontal Pie delantero Front baseboard	369x73x15
03	1/2	01	Rodapé traseiro Pie trasero Rear baseboard	369x73x15
04	1/2	01	Lateral direita Lateral derecha Right side	621x520x15
05	1/2	01	Fundo 15mm Fondo 15mm 15mm Bottom	618x385x15
06	1/2	01	Tampo 25mm Tapa 25mm 25mm top	535x400x25
07	1/2	01	Prateleira central Estante central Central shelf	450x384x15
08	1/2	01	Base Aéreo Base Aérea Air Base	520x370x15
09	1/2	01	Lateral Maior Lateral Mayor Larger Lateral	1754x520x15
10	1/2	01	Lateral Direita Aéreo Lateral Derecha Aéreo Right Side Air	1136x520x15
11	1/2	01	Prateleira Estante Shelf	400x370x15
12	1/2	01	Tampo superior Tapa superior Top panel	520x370x15
13	1/2	01	Fundo Superior Fondo superior Superior background	1132x395x3
14	1/2	01	Fundo Cru Fondo crudo Raw Background	581x395x3
15	1/2	04	Lado de gaveta Lado del cajón Side of drawer	350x90x15
16=19	1/2	02	Fundo de gaveta Fondo del cajón Drawer bottom	361x325x3
17	1/2	02	Ripa de trás Malla detrás Rear lath	344x90x15
18	1/2	02	Lado de gaveta maior Lado del cajón mayor Largest drawer side	350x180x15
19=16	1/2	01	Fundo de gaveta Fondo del cajón Drawer bottom	361x325x3
20	1/2	01	Ripa de trás maior Malla detrás mayor Larger rear lath	344x180x15
21	2/2	01	Porta Puerta Door	1129x391x15
22	2/2	02	Frente de Gaveta Menor Frente de cajón más pequeño Smaller Drawer Front	392x127x15
23	2/2	01	Frente de Gaveta Maior Frente del cajón más grande Front of Larger Drawer	392x280x15

Ferragens | Herrajes | Hardware

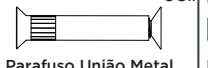
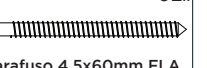
A	08x	B	16x	C	08x	D	26x	E	52x	F	08x	G	52x
													
Parafuso 4,5x50mm CHT. Tornillo 4,5x50mm CHT. Screw 4,5x50mm CHT.		Parafuso 3,5x40mm CHT. Tornillo 3,5x40mm CHT. Screw 3,5x40mm CHT.		Parafuso 3,5x22mm CHT. Tornillo 3,5x22mm CHT. Screw 3,5x22mm CHT.		Parafuso 3,5x14mm FLA. Tornillo 3,5x14mm FLA. Screw 3,5x14mm FLA.		Parafuso 3,5x12mm CHT. Tornillo 3,5x12mm CHT. Screw 3,5x12mm CHT.		Parafuso 3,0x30mm CHT. Tornillo 3,0x30mm CHT. Screw 3,0x30mm CHT.		Cavilha 8x25mm Cinta 8x25mm Dowel 8x25mm	
H	12x	I	04x	J	50x	K	08x	L	04x	M	03x	N	03x
													
Cantoneira plástica Cantonera plástica Plastic angle brackets		Prego 12x12mm Anelado Clavo 12x12mm Anillado Ringed Nails 12x12mm		Prego 10x10mm Clavo 10x10mm Nail 10x10mm		Porca cilíndrica Tuerca cilíndrica Cylindrical nut		Sapata "L" 16x20mm Zapata "L" 16x20mm "L" shoe 16x20mm		Corrediza telescópica Diapositivas telescópicas Telescopic slides		Dobradica SlideOn Alta Amort. 35mm Bisagra SlideOn Alta Amort. 35mm Hinge SlideOn High damper 35mm	
O	03x	P	04x	Q	02x	R	34x	S	05x	T	02x		
													
Calço Removível Calzado extraíble Removable Shim		Puxador Aleno Fit 300mm Tirador Aleno Fit 300mm Handle Aleno Fit 300mm		Sachê de cola Bolsa de pegamento Glue bag		Adesivo tapa parafuso 10mm Adhesivo tapón de tornillo 10mm Bolt cover adhesive 10mm		Parafuso União Metal Tornillo Unión Metal Metal Union Screw		Parafuso 4,5x60mm FLA. Tornillo 4,5x60mm FLA. Screw 4,5x60mm FLA.			

A união (S) deve ser usada somente quando este módulo for acoplado a outro módulo componível Henn, para unir duas peças de 15mm. Caso ele seja usado separadamente, a utilização do união não se faz necessário.

La unión (S) se debe utilizar sólo cuando el módulo está acoplado a otro módulo composable Henn, para unirse a dos 15mm piezas. Si se utiliza por separado, el uso de unión no es necesario.

The union (S) should be used only when this module is coupled to another Module Henn, to join two pieces of 15mm. If it is used separately, the use of the union is not necessary.

HENN

Ind. e Com. de Móveis Henn
Mondai - SC - Brasil

+55 49 3674.3500

@moveishenn
www.henn.com.br

INSTRUÇÕES DE MONTAGEM

INSTRUCCIONES DE MONTAJE
ASSEMBLY INSTRUCTIONS

Ponte Casal 4 Portas Seletto

Puente Casal 4 Puertas Seletto | Casal Bridge 4 Doors Seletto

c MC11-133 Areia HP

c MC11-184 Areia HP/Jequitibá

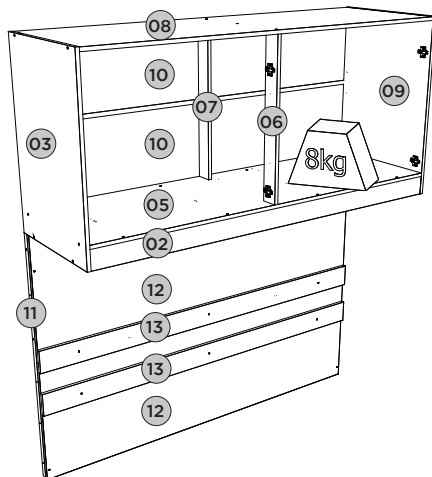
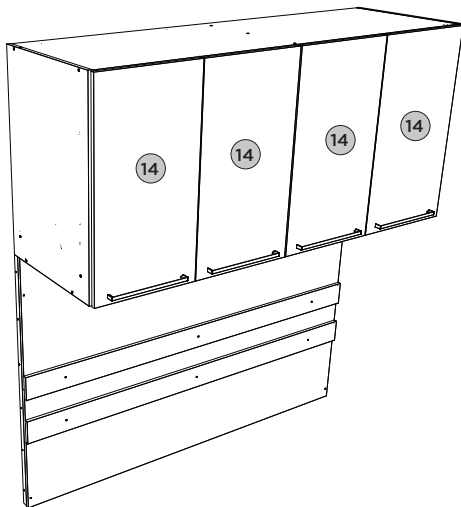

Requisitos para montagem
Requisitor para la montaje
Assembly Requirements

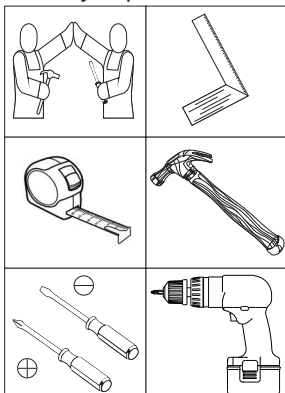

Imagens meramente ilustrativas
Imágenes meramente ilustrativas
Images for illustration only

Pesos máximos recomendados com carga distribuída
Peso máximo recomendado con la carga distribuída
Recommended maximum weights with evenly distributed.

AVISO

Para limpeza de seu móvel, use uma flanela seca ou umedecida, e não utilize produtos químicos que possam danificar seu produto.

SISTEMA DE MONTAGEM

O sistema de montagem dos produtos, funciona de acordo com a ordem crescente dos números indicados no desenho. Ex: 01, 02, 03, 04... até a conclusão da montagem.

ADVERTENCIA

Para limpieza de su móvil, use una flanela seca o húmeda, y no utilice productos químicos que puedan dañar su producto.

SISTEMA DE MONTAJE

El sistema de montaje de los productos funciona de acuerdo con el orden creciente de los números indicados en el dibujo. Ej.: 01, 02, 03, 04... hasta la conclusión del montaje.

NOTICE

To clean your furniture, use a dry or wet cloth, and do not use chemicals that may damage your product.

ASSEMBLY SYSTEM

The products' assembly system works according to the increasing order of the indicated numbers. For example: 01, 02, 03, 04 ... to the end of the assembly.

1

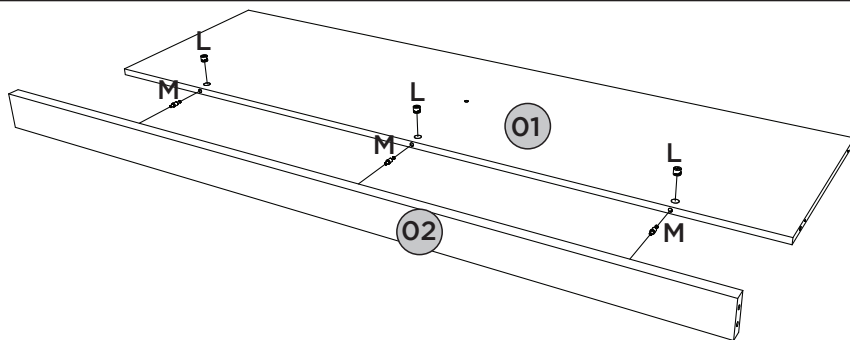

2

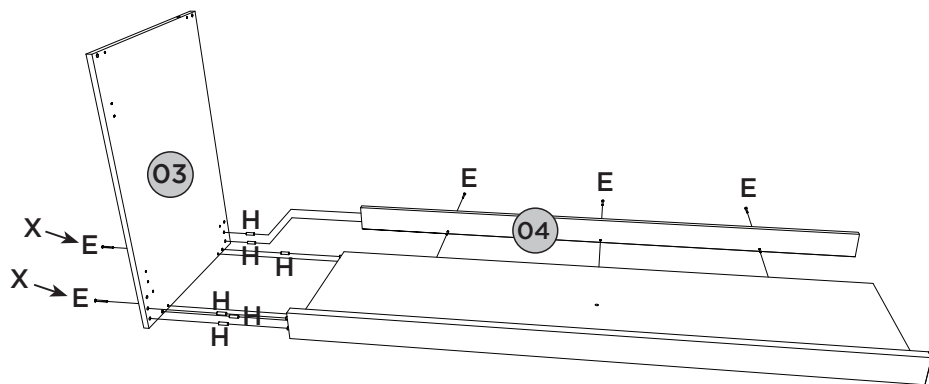

3

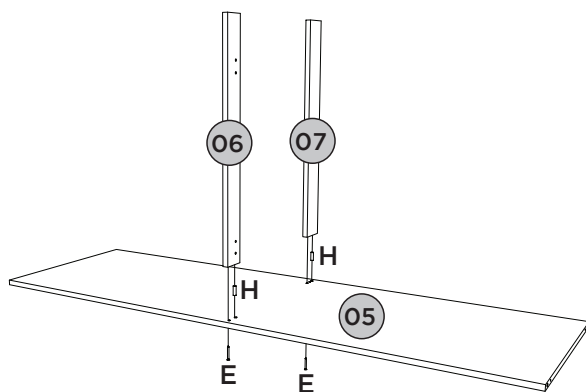

4

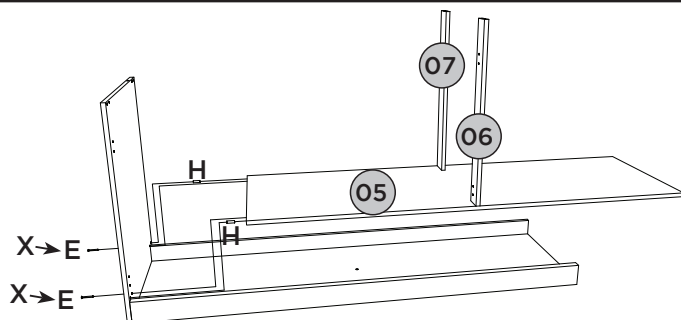

2

5

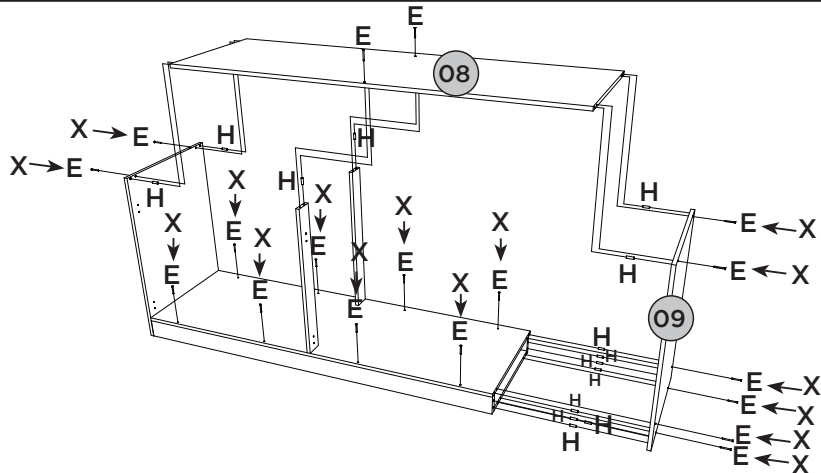

6

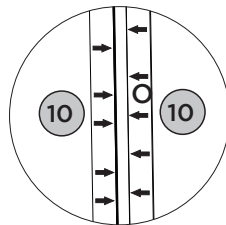
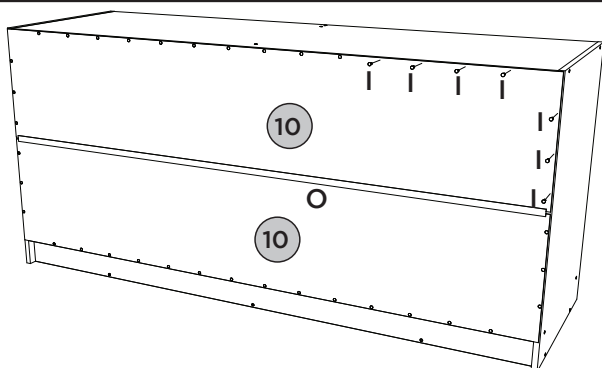

7

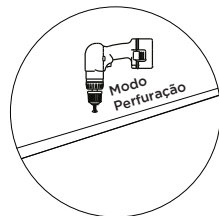
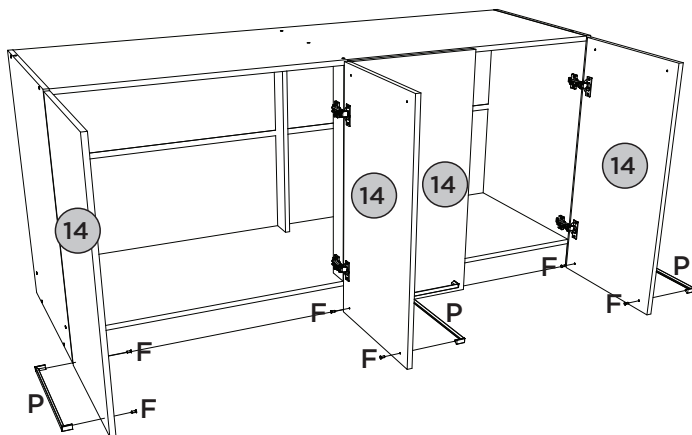
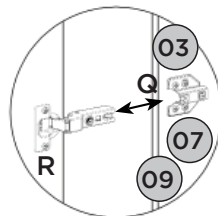
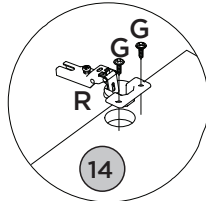
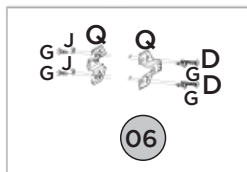
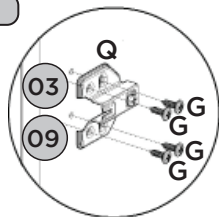

Fazer furação passante para fixar os puxadores, utilizando as pré marcações existentes nas portas.

Taladre agujeros para fijar las manijas, utilizando las marcas previas en las puertas.

Drill through holes to fix the handles, using the pre-markings on the doors.

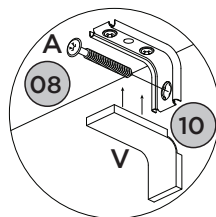
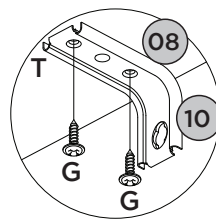
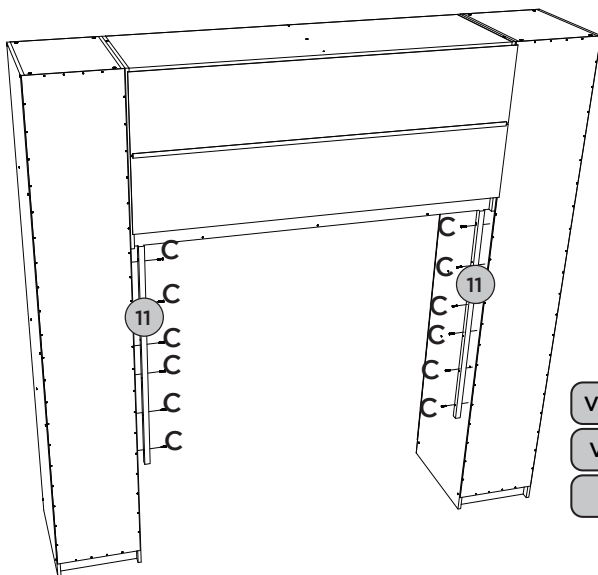

Vista Traseira

Vista trasera

Back view



Mesa Cabeceira Seletto 1Pt 3Gav.

Mesita De Noche Seletto 1Pt 3Gav.

Bedside Table Seletto 1Pt 3Gav.

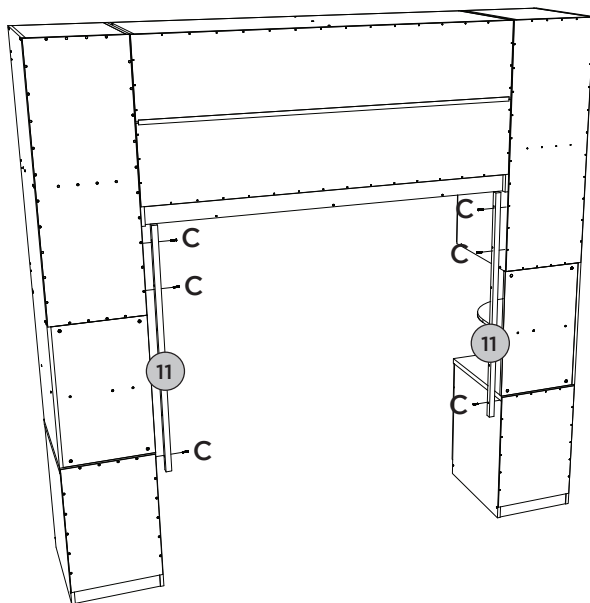

Para simulação de montagem dos fundos foram utilizados móveis componíveis da mesma linha.

Para la simulación de montaje de fondos se utilizaron muebles componible la misma línea.

For simulation of assembly of the funds were used furniture of the same line.

Para a colocação dos apoios estruturais (11) fazer o alinhamento dos mesmos com a parte de trás da lateral dos móveis ao lado.

Para la colocación del soporte estructural (11) del mismo a alinear con el lado posterior de la parte móvil.

For the placement of the supports Structural Funds (11) to aligning them with the back side of the furniture next to it.

9

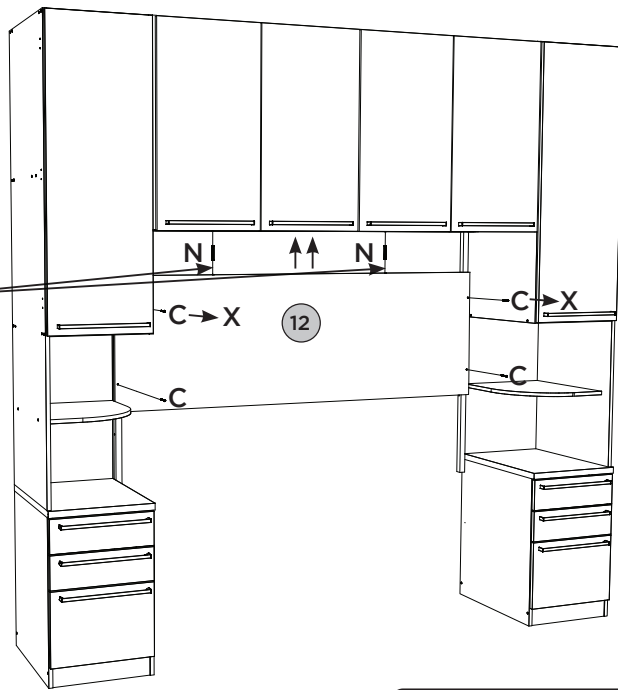
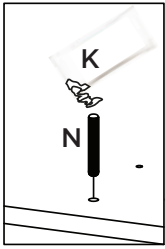

Mesa Cabeceira Seletto 1Pt 3Gav.

Mesita De Noche Seletto 1Pt 3Gav.

Bedside Table Seletto 1Pt 3Gav.

10

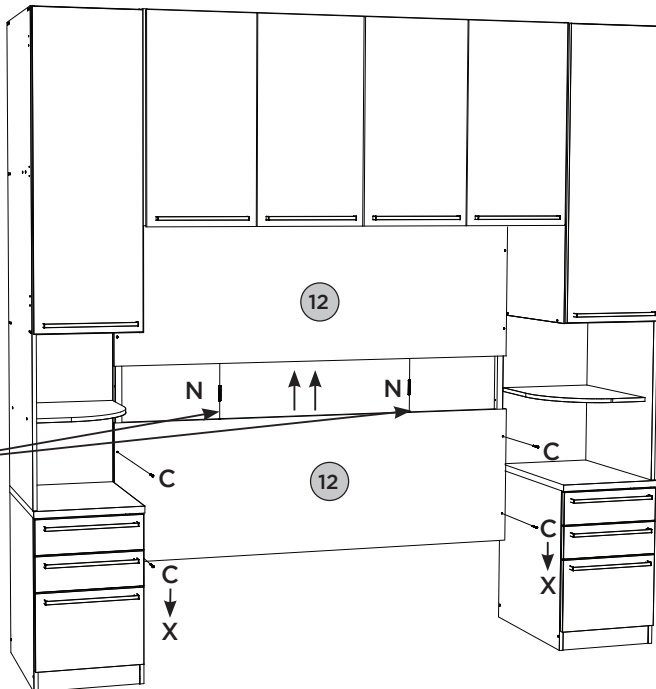
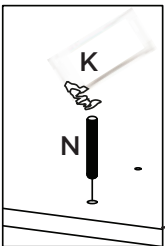

11

Colocação dos apliques nos fundos.

La colocación de los apliques en fondos.

Placement of the appliques in the back.

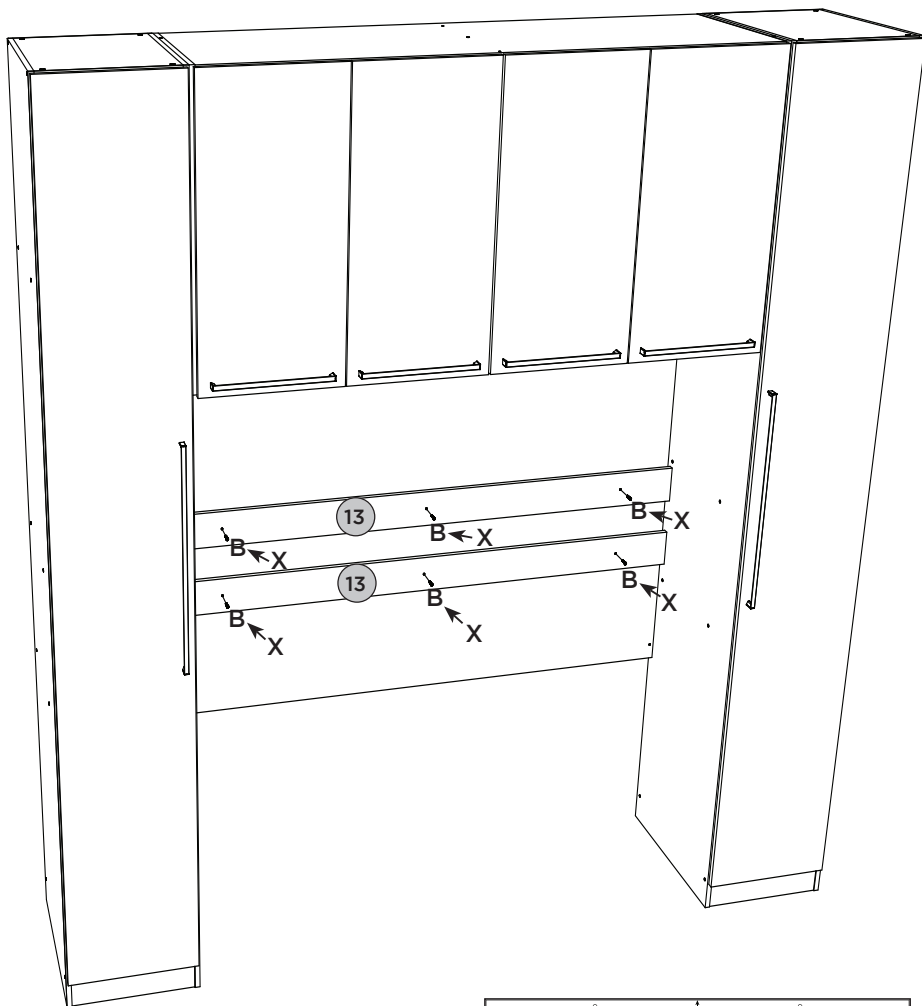

Medidas recomendadas para a colocação dos apliques nos fundos.

Medidas recomendadas para la colocación de accesorios en los fondos.

Recommended measures for the placement of the appliques on the back.

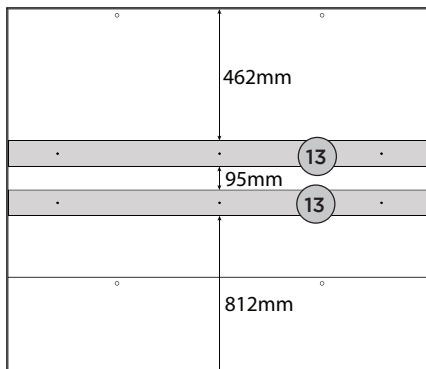

12



Opção com Mesa de Cabeceira.

Opción con Mesita de Noche.

Option with Bedside Table.

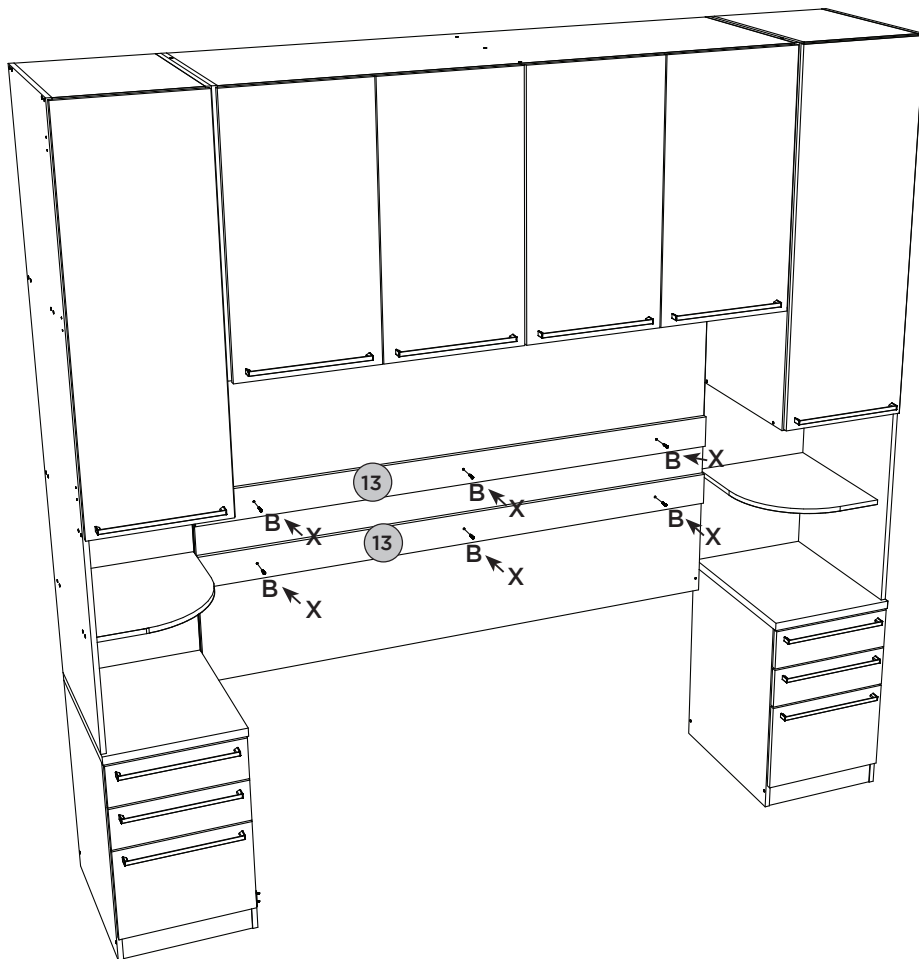

Medidas recomendadas para a colocação dos apliques nos fundos.





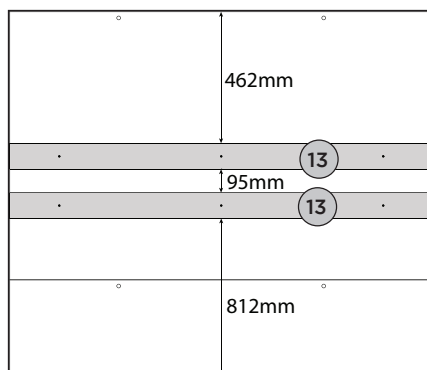





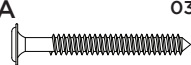









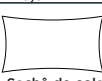

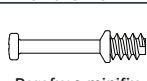
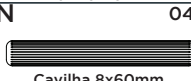
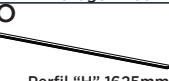
Medidas recomendadas para la colocación de accesorios en los fondos.

Recommended measures for the placement of the appliques on the back.

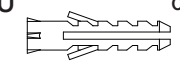

Item	Caixa Caja Box	Qtd Ctd Qty	Descrição Descripción Description	Medidas (mm) Dimensions (mm) Size (measurements) (mm)
01	1/3	01	Base Base Base	1620x454x15
02	2/3	01	Travessa Frontal Travesaño delantero Front Tray	1620x80x25
03	1/3	01	Lateral esquerda Lateral izquierda Left side	760x520x15
04	2/3	01	Travessa Traseira travesaño trasero Rear Tray	1620x80x15
05	1/3	01	Base Interna Base interna Internal Base	1620x520x15
06	2/3	01	Pilastra da Porta Puerta pilastra Door Pilaster	649x70x15
07	2/3	01	Pilastra Pilastra Pilaster	649x70x15
08	1/3	01	Tampo Tapa Top	1620x520x15
09	1/3	01	Lateral direita Lateral derecha Right side	760x520x15
10	2/3	02	Fundo Fondo Bottom	1645x335x3
11	2/3	02	Apoio estrutural Apoyo estructural Structural support	1092x25x25
12	2/3	02	Fundo 15mm Fondo 15mm 15mm Bottom	1650x546x15
13	1/3	02	Aplique Aplique Apply	1650x100x15
14	3/3	04	Porta Puerta Door	760x405x15

Ferragens | Herrajes | Hardware

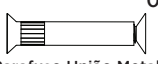
A  Parafuso 5,0x50mm FLA. Tornillo 5,0x50mm FLA. Screw 5,0x50mm FLA.	B  Parafuso 4,0x25mm CHT. Tornillo 4,0x25mm CHT. Screw 4,0x25mm CHT.	C  Parafuso 4,0x35mm CHT. Tornillo 4,0x35mm CHT. Screw 4,0x35mm CHT.	D  Parafuso 4,0x25mm MET FLA. Tornillo 4,0x25mm MET FLA. Screw 4,0x25mm MET FLA.	E  Parafuso 3,5x40mm CHT. Tornillo 3,5x40mm CHT. Screw 3,5x40mm CHT.
F  Parafuso 3,5x22mm CHT. Tornillo 3,5x22mm CHT. Screw 3,5x22mm CHT.	G  Parafuso 3,5x14mm FLA. Tornillo 3,5x14mm FLA. Screw 3,5x14mm FLA.	H  Cavilha 8x25mm Cinta 8x25mm Dowel 8x25mm	I  Prego 10x10mm Clavo 10x10mm Nail 10x10mm	J  Porca Sextavada Tuerca Hexagonal Hexagon Nut
K  Sachê de cola Bolsa de pegamento Glue bag	L  Tambor minifix Tambor minifix Minifix drum	M  Parafuso minifix Tornillo minifix Minifix bolt	N  Cavilha 8x60mm Cinta 8x60mm Dowel 8x60mm	O  Perfil "H" 1625mm Perfil "H" 1625mm Profile "H" 1625mm
P  Puxador Aleno Fit Alumínio Mango de alumínio Aleno Fit Aleno Fit Aluminum Handle	Q  Calço Removível Calzado extraíble Removable Shim	R  Dobradiça SlideOn Alta Amort. 35mm Bisagra SlideOn Alta Amort. 35mm Hinge SlideOn High damper 35mm	S  Etiqueta resinada Henn Etiqueta resinada Henn Henn resin label	T  Suporte de fixação Soporte de fijación Mounting bracket
U  Buchá plástica 8mm Buchá de plástico 8mm 8mm plastic bushing	V  Proteção para cantoneira Ángulo de protección Protection angle	W  Giz de correção Tiza de corrección Chalk of correction	X  Adesivo tapa parafuso 10mm Adhesivo tapón de tornillo 10mm Bolt cover adhesive 10mm	Y  Parafuso União Metal Tornillo Unión Metal Metal Union Screw

A união (Y) deve ser usada somente quando este módulo for acoplado a outro módulo componível Henn, para unir duas peças de 15mm. Caso ele seja usado separadamente, a utilização do união não se faz necessário.

La unión (Y) se debe utilizar sólo cuando el módulo está acoplado a otro módulo composable Henn, para unirse a dos 15mm piezas. Si se utiliza por separado, el uso de unión no es necesario.

The union (Y) should be used only when this module is coupled to another Module Henn, to join two pieces of 15mm. If it is used separately, the use of the union is not necessary.

RECOMENDAÇÃO

Para fixar o móvel na parede usar o suporte de fixação (T), o parafuso 3,5x14mm FLA (G), a Bucha 8mm (U) e o parafuso 5,0x50mm FLA (A)

RECOMENDACIÓN

Para conectar el móvil a la pared con el soporte (T), tornillo 3,5x14mm FLA (G), el casquillo de 8 mm (U) y el 5,0x50mm tornillo FLA (A).

RECOMMENDATION

To connect the mobile to the wall with the bracket (T), screw 3.5x14mm FLA (G), the socket 8mm (U) and the 5.0x50mm screw FLA (A).

HENN

Ind. e Com. de Móveis Henn
Mondai - SC - Brasil

+55 49 3674.3500

@moveishenn
www.henn.com.br

INSTRUÇÕES DE MONTAGEM

INSTRUCCIONES DE MONTAJE
ASSEMBLY INSTRUCTIONS

Canto Closet 2 Portas Seletto | Armario Esquina 2 Puertas Seletto | Corner Closet 2 Doors Seletto

MC05-133 Areia HP
MC05-184 Areia HP/Jequitibá
MC06-133 Areia HP
MC06-184 Areia HP/Jequitibá

Opção 1
Opción 1
Option 1

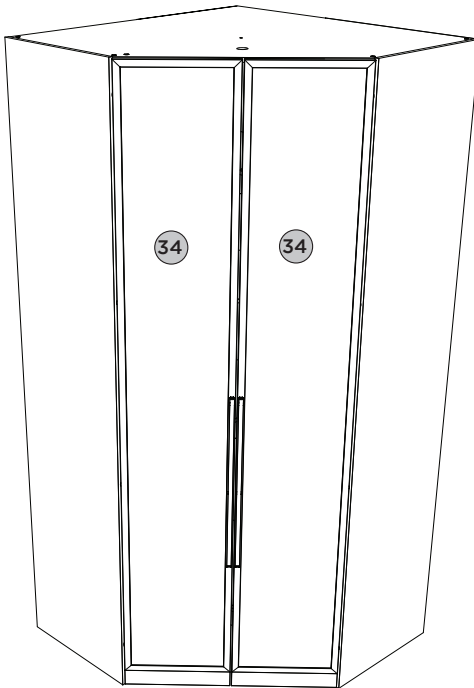

Opção 2
Opción 2
Option 2

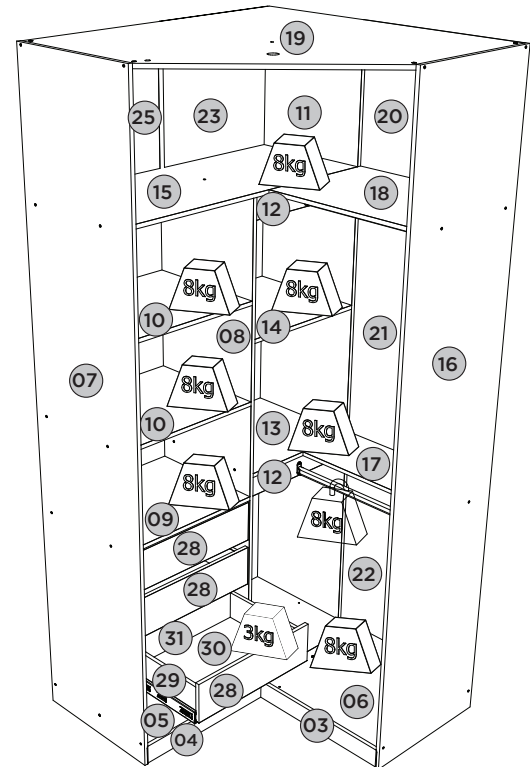

Pesos máximos recomendados com carga distribuída
Peso máximo recomendado con la carga distribuida
Recommended maximum weights with evenly distributed.

Requisitos para montagem
Requisitor para la montaje
Assembly Requirements

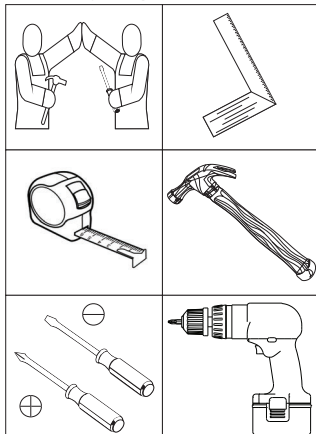

Imagens meramente ilustrativas
Imágenes meramente ilustrativas
Images for illustration only

A união (AB) deve ser usada somente quando este módulo for acoplado a outro módulo componível Henn, para unir duas peças de 15mm. Caso ele seja usado separadamente, a utilização do união não se faz necessário.



La unión (AB) se debe utilizar sólo cuando el módulo está acoplado a otro módulo composable Henn, para unirse a dos 15mm piezas. Si se utiliza por separado, el uso de unión no es necesario.



The union (AB) should be used only when this module is coupled to another Module Henn, to join two pieces of 15mm. If it is used separately, the use of the union is not necessary.



AVISO

Para limpeza de seu móvel, use uma flanela seca ou umedecida, e não utilize produtos químicos que possam danificar seu produto.

SISTEMA DE MONTAGEM

O sistema de montagem dos produtos, funciona de acordo com a ordem crescente dos números indicados no desenho. Ex.: 01, 02, 03, 04... até a conclusão da montagem.

ADVERTENCIA

Para limpieza de su móvil, use una flanela seca o húmeda, y no utilice productos químicos que puedan dañar su producto.

SISTEMA DE MONTAJE

El sistema de montaje de los productos funciona de acuerdo con el orden creciente de los números indicados en el dibujo. Ej.: 01, 02, 03, 04... hasta la conclusión del montaje.

NOTICE

To clean your furniture, use a dry or wet cloth, and do not use chemicals that may damage your product.

ASSEMBLY SYSTEM

The products' assembly system works according to the increasing order of the indicated numbers. For example: 01, 02, 03, 04 ... to the end of the assembly.

1

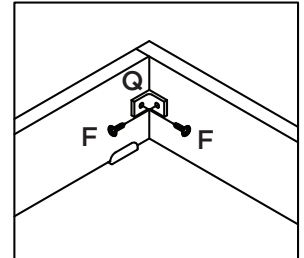
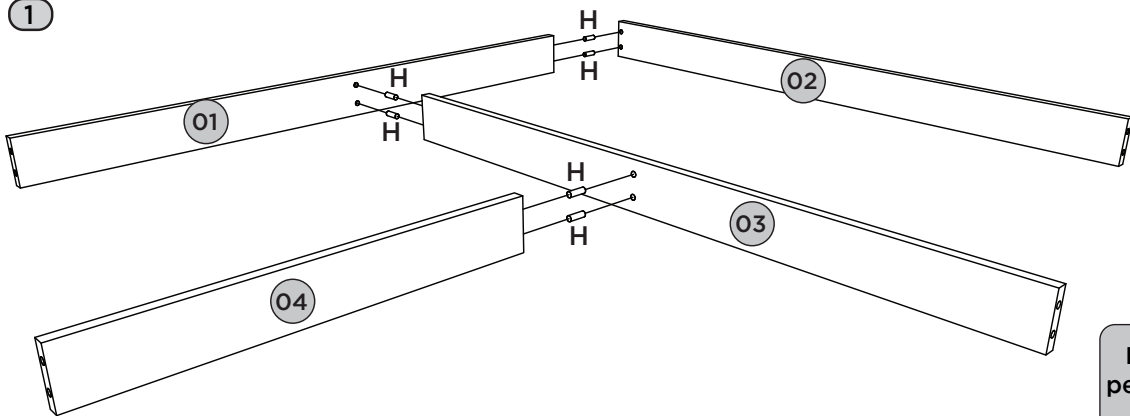

Fixação das cantoneiras nas peças de nº (01 e 02), (01 e 03) e (03 e 04).

La fijación de los ángulos en el número de piezas (01 y 02), (01 y 03) y (03 y 04).

Fixation of the angles in pieces (01 and 02), (01 and 03) and (03 and 04).

2

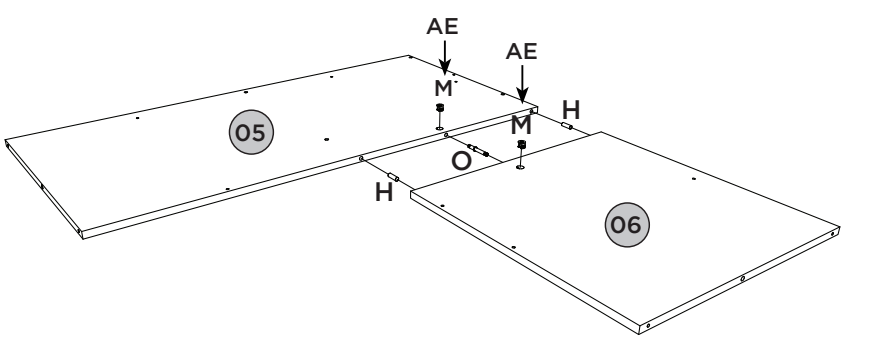

3

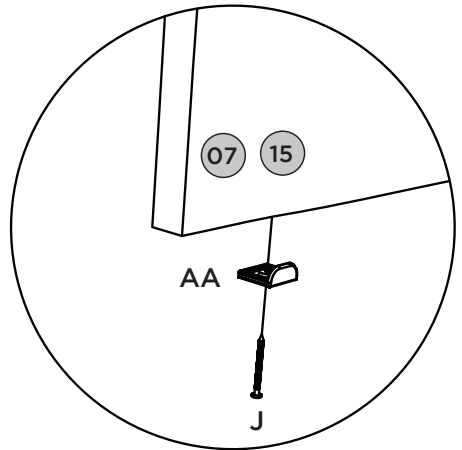
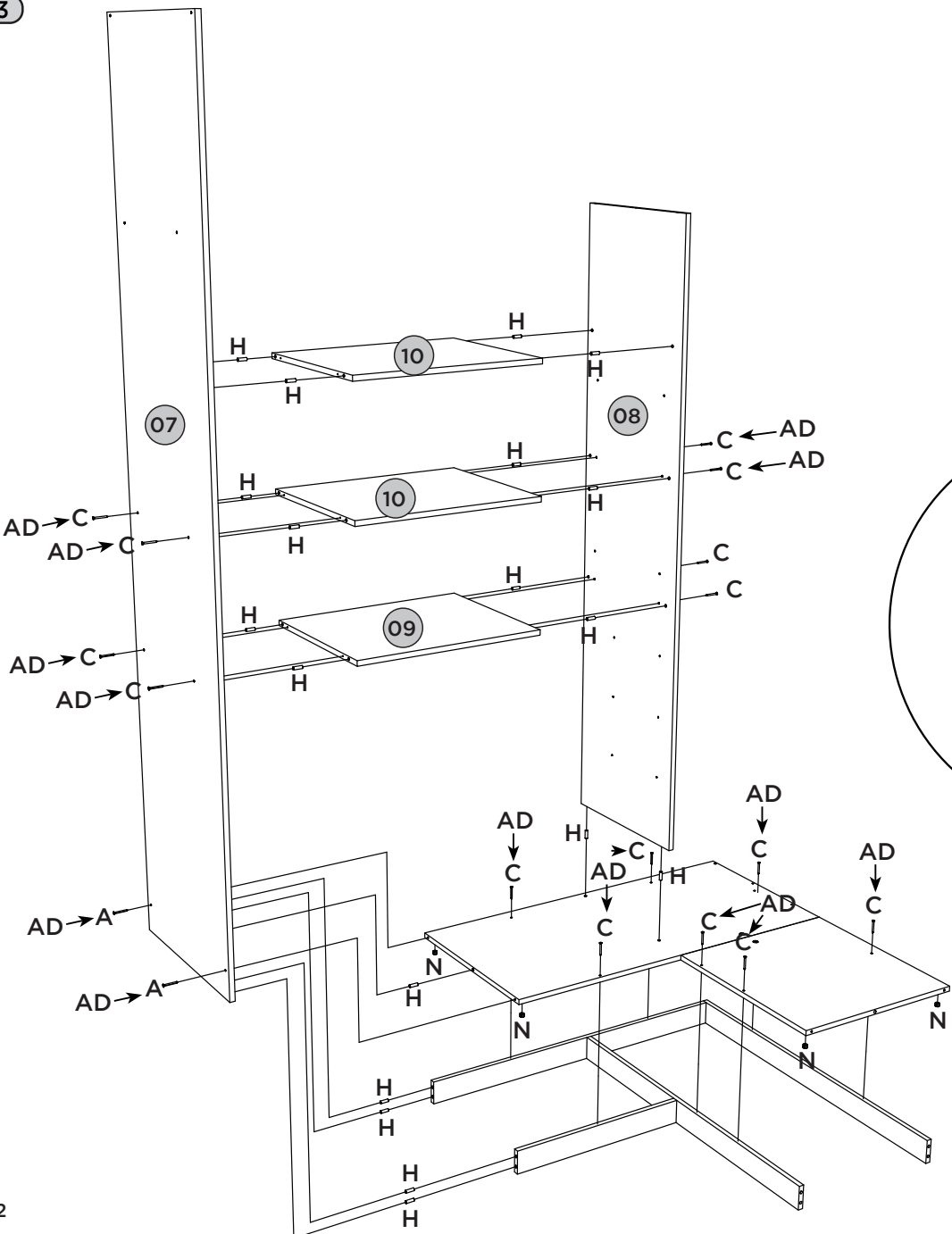

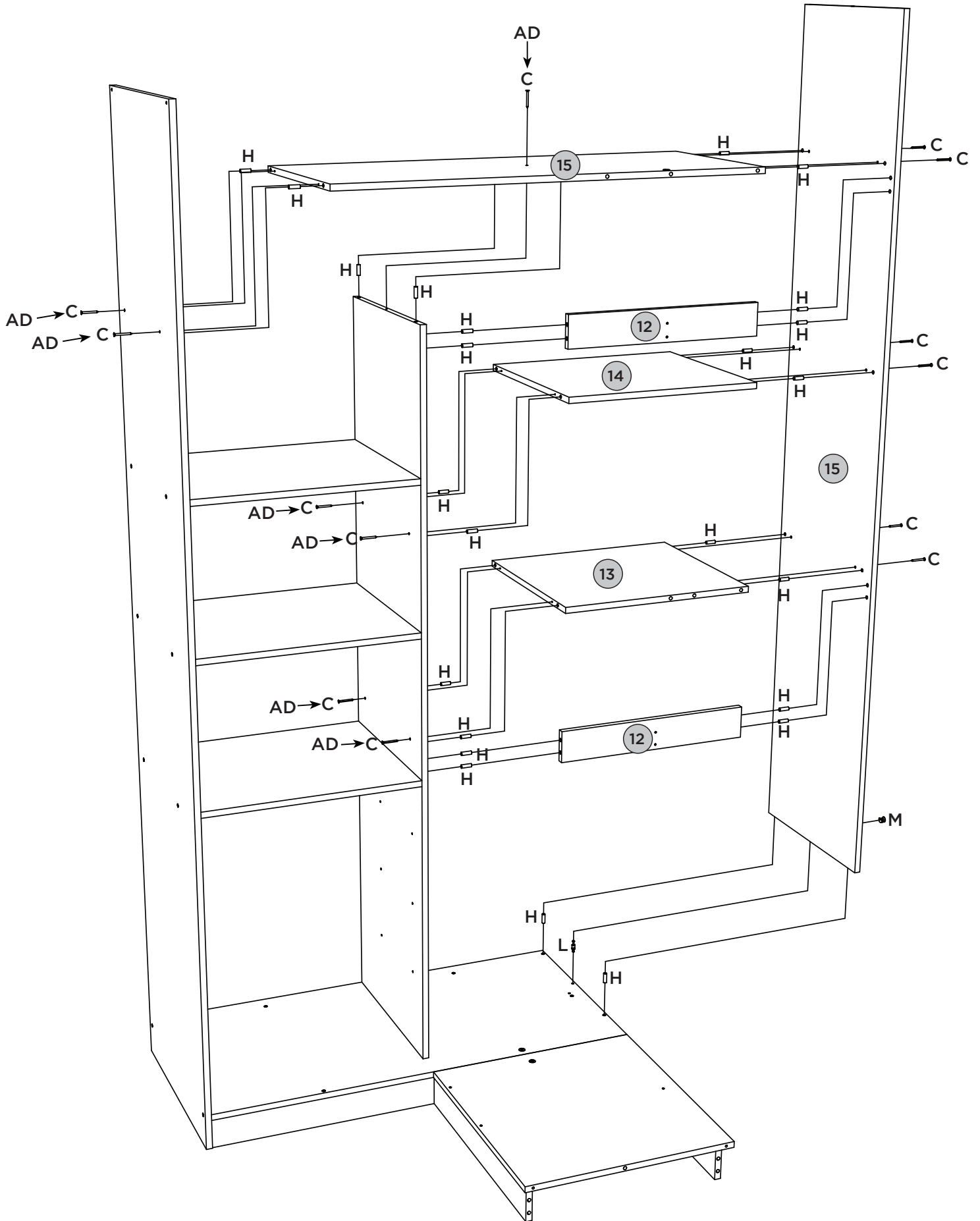

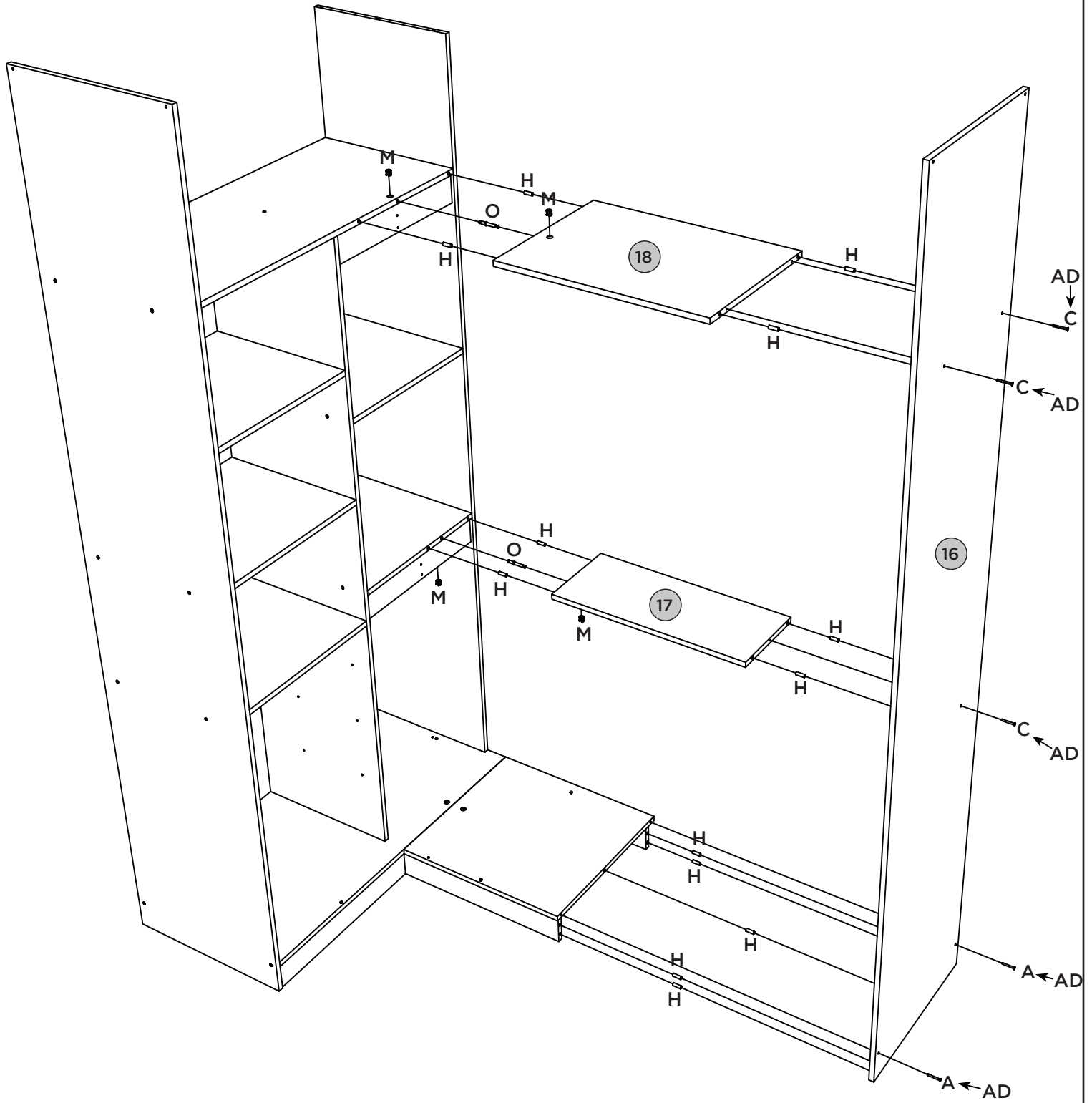

6

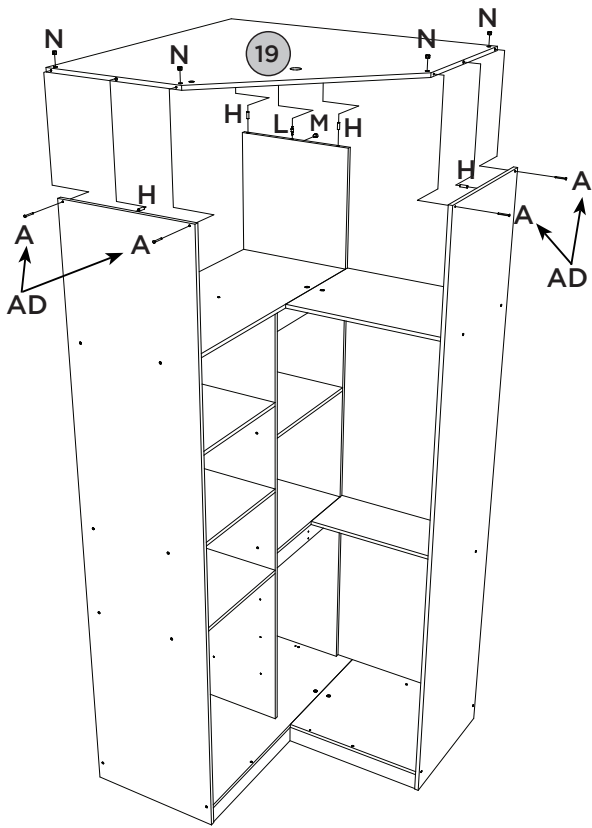

7

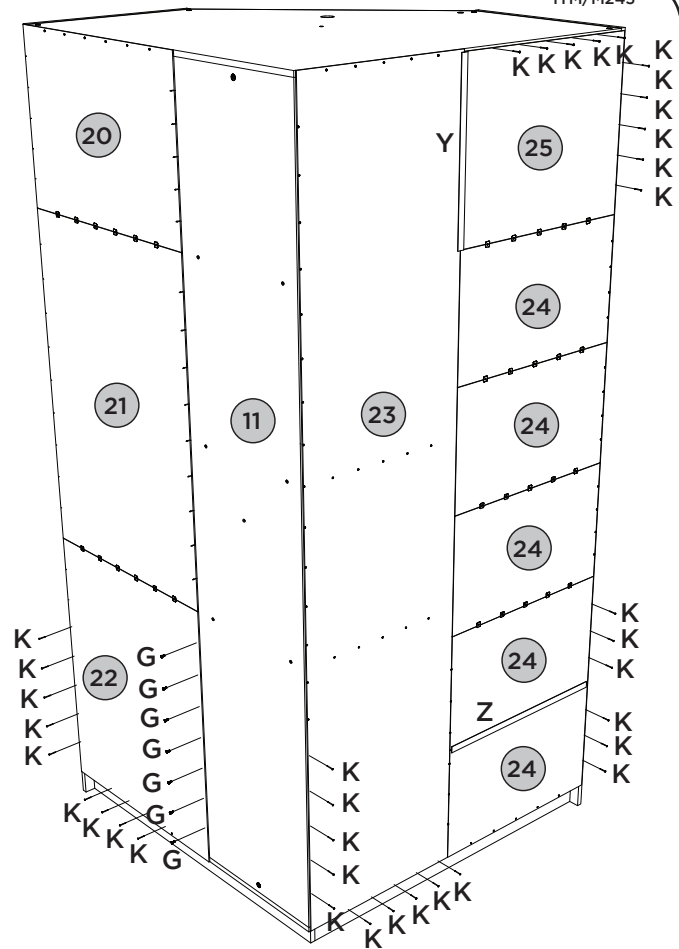

8 Fixação do Kit Led no produto Fijación Led Kit Producto

Led Kit fixing on product

Fixar Interruptor com 2 parafusos 3,5x14 do Kit (Imagem interna)

Seguro al conmutador con 2 tornillos 3,5x14 Kit (imagen interna)

Attach Switch with 2 3.5x14 Kit Screws (Internal Image)

IMPORTANTE: Para realizar as conexões dos terminais é necessário utilizar a Instrução que acompanha o Kit.

IMPORTANTE: Para realizar las conexiones de los terminales debe utilizar la instrucción que viene con el kit.

IMPORTANTE: Para realizar as conexões dos terminais é necessário utilizar a Instrução que acompanha o Kit.

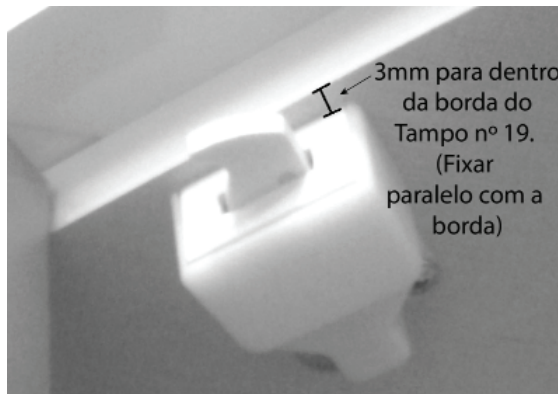

3mm para dentro da borda do Tampo nº 19. (Fixar paralelo com a borda)

Luminária Led (Imagem interna)

Lâmpara llevada (Imagen interna)

Led Light (Internal Image)

Luminária Led (Vista Superior)

Lâmpara llevada (Vista superior)

Luminária Led (Vista Superior)

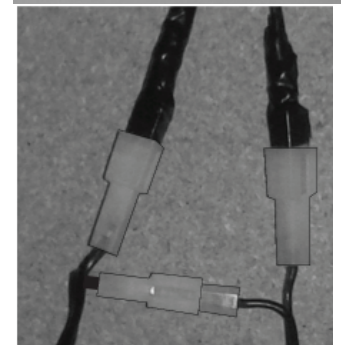

Toda fiação e o plug devem ficar na parte superior do produto

Todo el cableado y el enchufe tienen que estar en la parte superior del producto

All wiring and plug should be on the top of the product

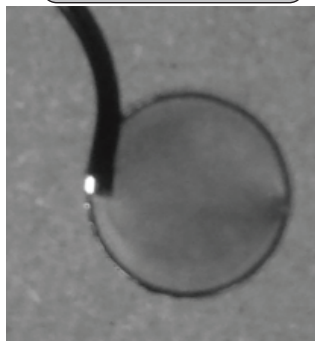
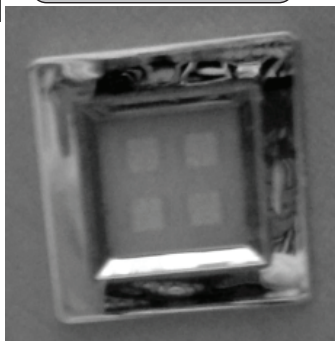

8

Fazer furação passante para fixar os puxadores, utilizando as pré marcações existentes nas portas.

Taladre agujeros para fijar las manijas, utilizando las marcas pre-vias en las puertas.

Drill through holes to fix the handles, using the pre-markings on the doors.

Colocar cola nas cavilhas plásticas 8x29mm

Poner pegamento en los pernos 8x29mm plástica

Put glue in plastic pins 8x29mm

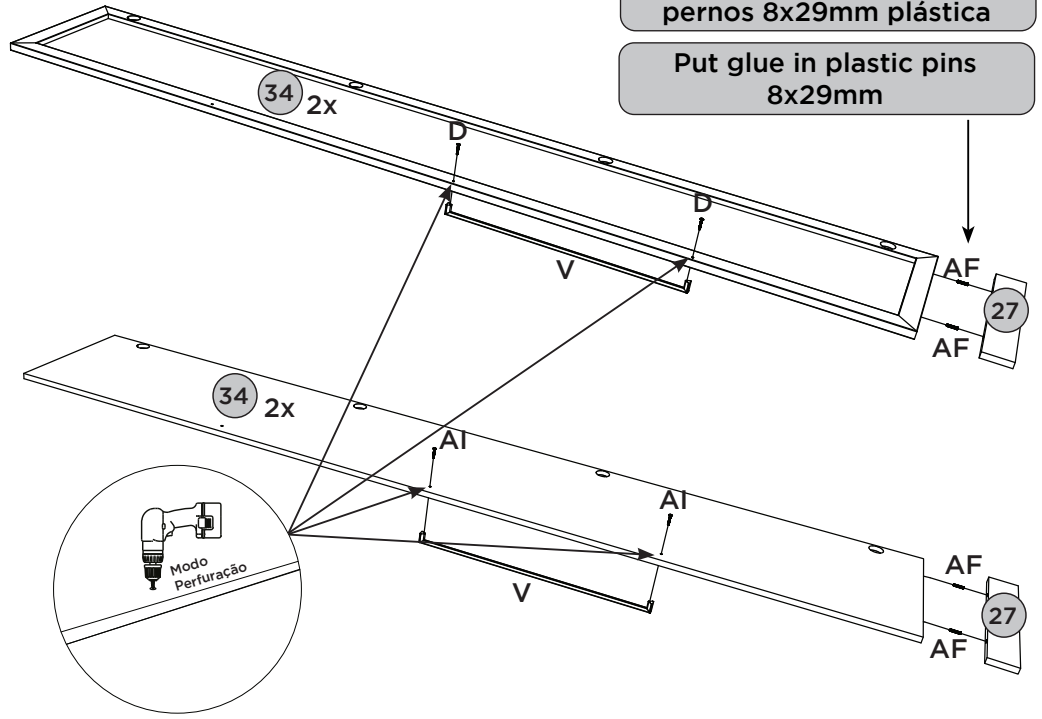

9

Opção 1
Opción 1
Option 1

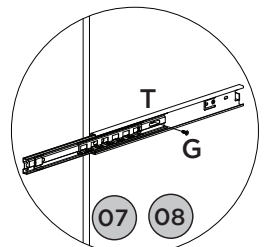
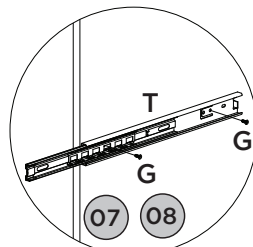
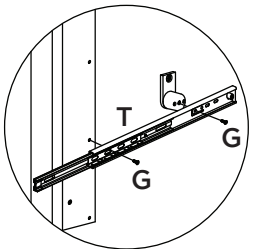
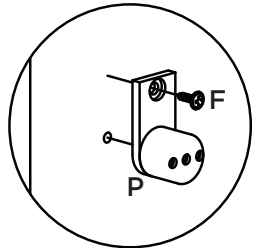
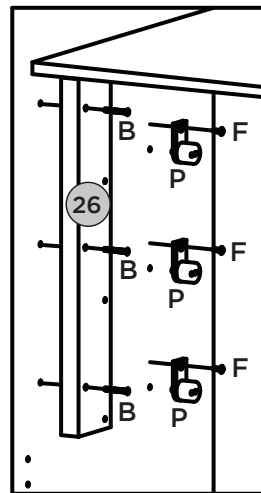
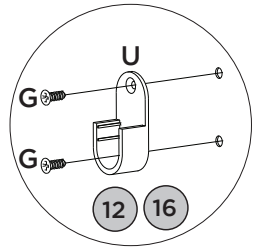
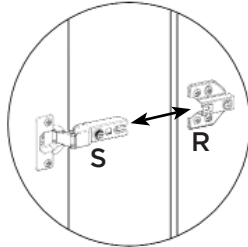
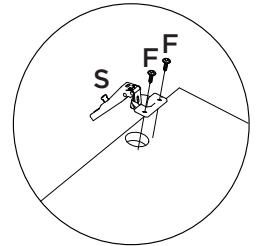
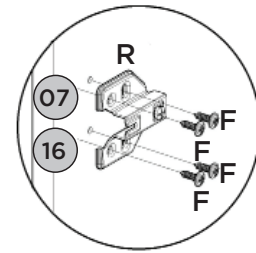
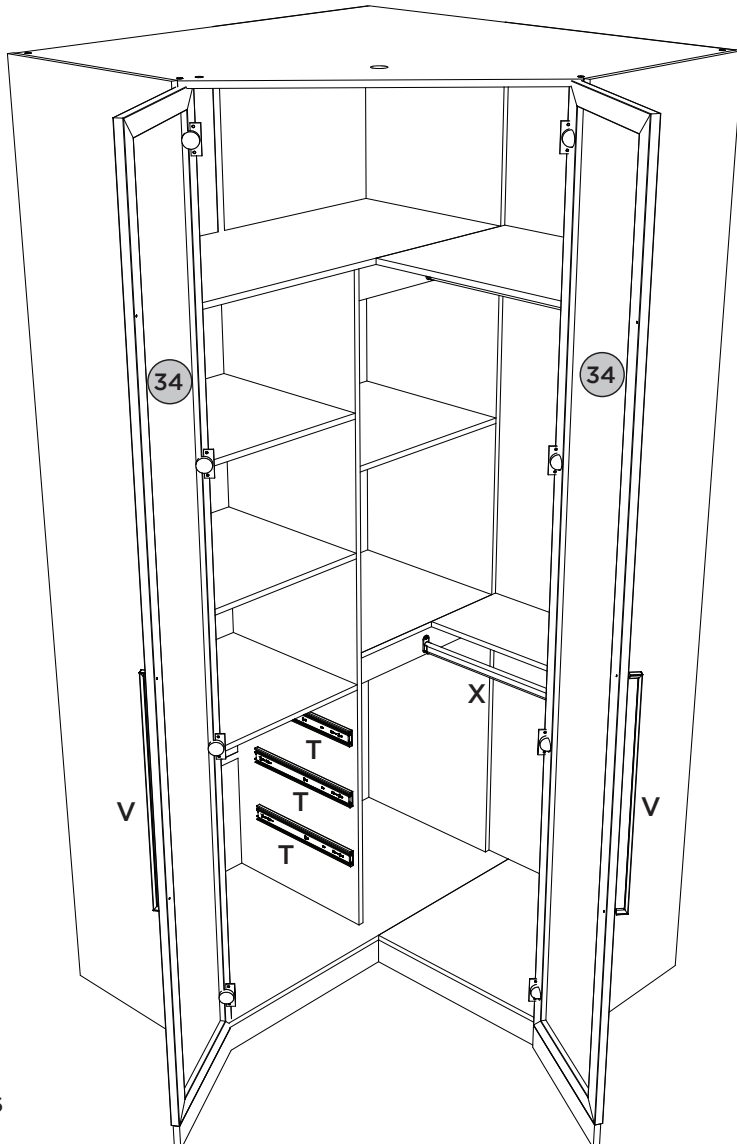

10

Opção 2
Opción 2
Option 2

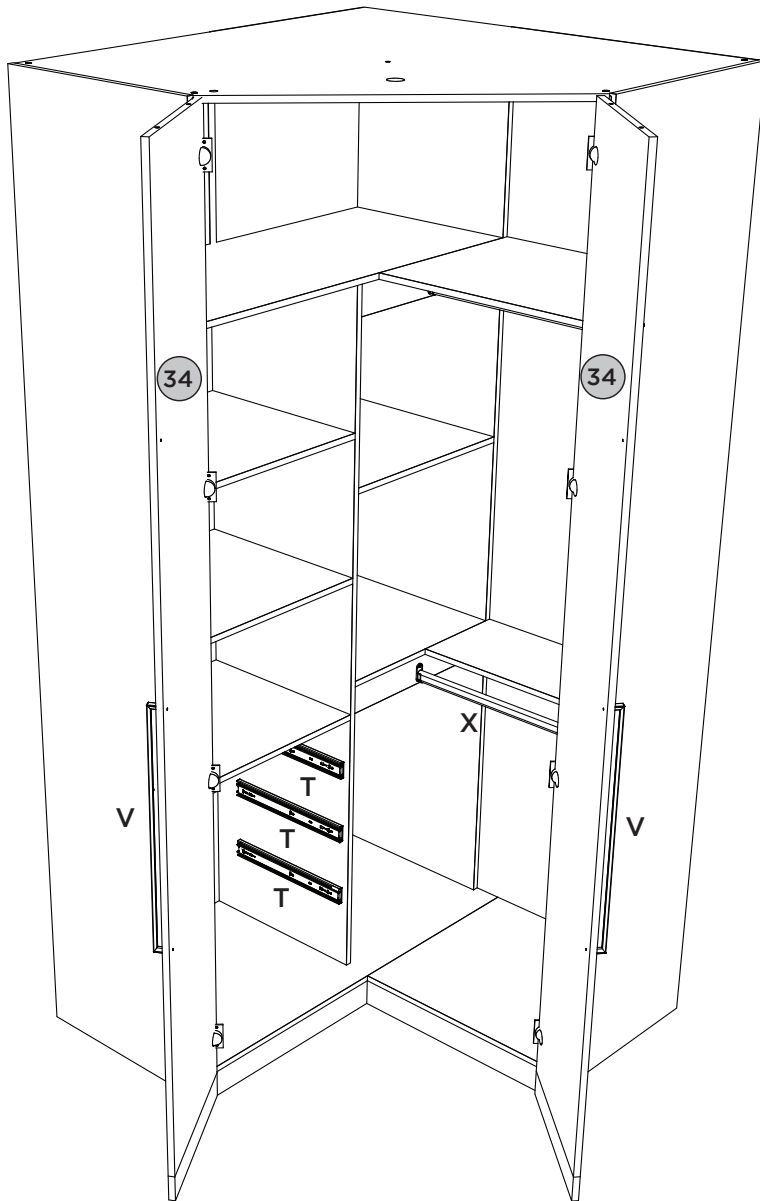

11

ITM/M245-

Montagem gaveta 3x.

Monte cajón 3x.

Mounting drawer 3x.

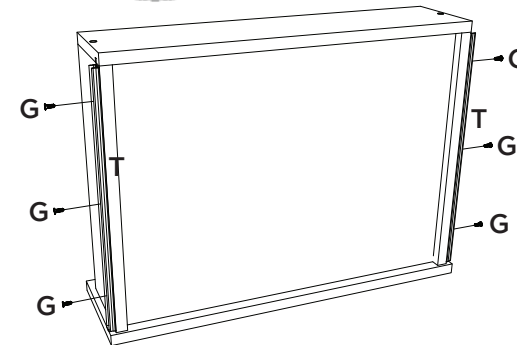
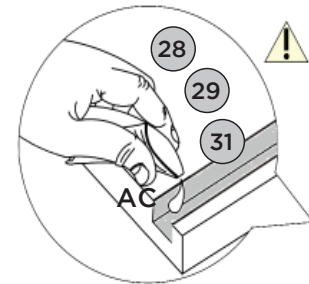
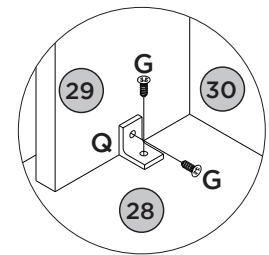
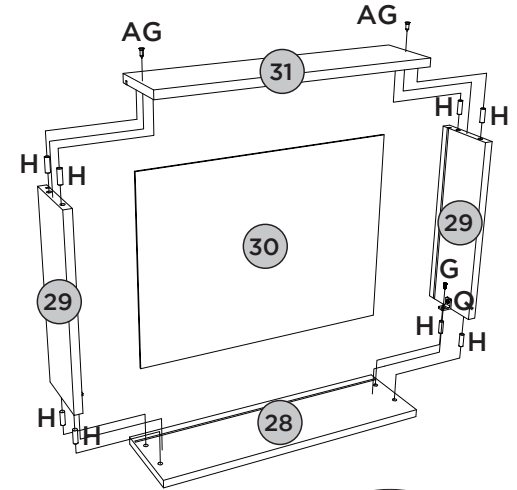

12

A Gaveta Superior é igual as demais gavetas, porém com divisórias.

El Top Drawer es igual también la cajones, pero con separadores.

The Upper Drawer is the same as the other drawers, but with dividers.

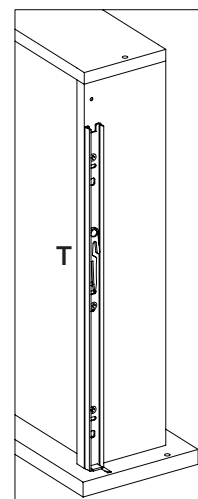
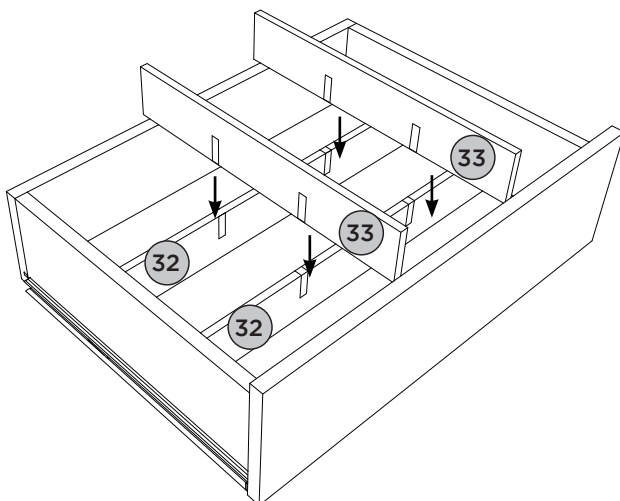















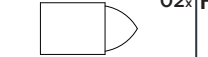

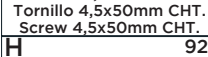
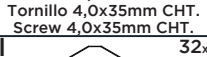
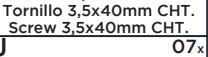
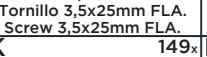
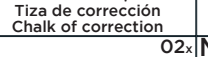
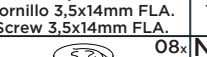
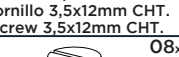
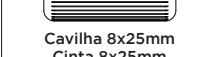
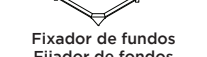

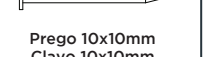
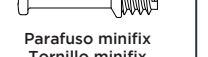
A corredeira (T) deverá ser alinhada com a parte de baixo do lado de gaveta (29)

La corredera (T) debe ser alineada con la parte de por el lado del cajón (29)

The slide (T) should be aligned with the underside of the drawer side (29)

Item	Caixa Caja Box	Qtd Ctd Qty	Descrição Descripción Description	Medidas (mm) Dimensions (mm) Size (measurements) (mm)
01	1/4	01	Rodapé Traseiro Menor Rodapié trasero menor Rear Footer Minor	1028x73x15
02	1/4	01	Rodapé Traseiro Maior Rodapié trasero mayor Larger Back Footer	1043x73x15
03	1/4	01	Rodapé frontal maior Rodapié frontal mayor Larger front footer	1028x73x15
04	1/4	01	Travessa do rodapé Carril pie Baseboard crosspiece	558x73x15
05	1/4	01	Base maior Base mayor Larger base	1075x520x15
06	3/4	01	Base Base Base	555x520x15
07	2/4	01	Lateral esquerda Lateral izquierda Left side	2400x520x15
08	2/4	01	Divisão División Division	1807x450x15
09	1/4	01	Tampo das gavetas Tapa de los cajones Drawer top	555x450x15
10	3/4	02	Prateleira fixa Estante fija Fixed shelf	555x450x15
11	2/4	01	Fundo 15mm Fondo 15mm 15mm Bottom	2296x450x15
12	1/4	02	Travessa sustentação Apoyo travesaño Support rail	490x80x15
13	1/4	01	Prateleira Menor Estante menor Minor shelf	490x450x15
14	1/4	01	Prateleira menor central Estante inferior centro Central Smallest Shelf	490x450x15
15	1/4	01	Prateleira maior Estante mayor Largest shelf	1060x450x15
16	2/4	01	Lateral direita Lateral derecha Right side	2400x520x15
17	3/4	01	Prateleira do calceiro Estante del calzón Shelf calceiro	625x250x15
18	3/4	01	Prateleira superior direita Estante superior derecha Right upper shelf	625x450x15
19	3/4	01	Tampo superior Tapa superior Top panel	1075x1075x15
20	3/4	01	Fundo Superior Fondo superior Superior background	652x496x3
21	3/4	01	Fundo central Fondo central Central fund	1007x652x3
22	3/4	01	Fundo Inferior Fondo inferior bottom background	821x652x3
23	2/4	01	Fundo maior Fondo mayor Larger background	2324x507x3
24	3/4	05	Fundo Fondo Bottom	572x365x3
25	1/4	01	Fundo menor superior Fondo inferior superior Top lower bottom	572x489x3
26	1/4	01	Ripa lateral Listón lateral Ripa side	530x80x25
27	1/4	02	Moldura frontal inferior Cornija frontal inferior Bottom front bezel	391x68x15
28	3/4	03	Frente de gaveta Frente de cajón Front of drawer	522x152x15
29	3/4	06	Lado de gaveta Lado del cajón Side of drawer	350x122x15
30	3/4	03	Fundo de gaveta recortado Fondo de cajón recortado Drawer bottom trimmed	486x361x3
31	1/4	03	Ripa de trás Malla detrás Rear lath	505x122x15
32	3/4	02	Divisória Maior Divisoria Mayor Greater Divisory	474x60x9
33	3/4	02	Divisória Menor División Menor Small Partition	349x60x9
34	4/4	02	Porta Espelho Puerta de espejo Mirror Door	2320x391x20
34	4/4	02	Porta Puerta Door	2320x291x15

Ferragens | Herrajes | Hardware

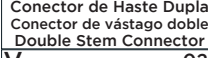
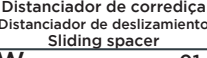
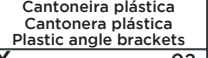
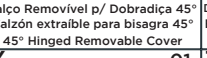
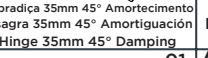
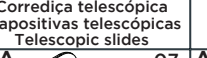
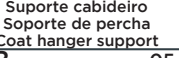
A  Parafuso 4,5x50mm CHT. Tornillo 4,5x50mm CHT. Screw 4,5x50mm CHT.	B  Parafuso 4,0x35mm CHT. Tornillo 4,0x35mm CHT. Screw 4,0x35mm CHT.	C  Parafuso 3,5x40mm CHT. Tornillo 3,5x40mm CHT. Screw 3,5x40mm CHT.	D  Parafuso 3,5x25mm FLA. Tornillo 3,5x25mm FLA. Screw 3,5x25mm FLA.	E  Giz de correção Tiza de corrección Chalk of correction	F  Parafuso 3,5x14mm FLA. Tornillo 3,5x14mm FLA. Screw 3,5x14mm FLA.	G  Parafuso 3,5x12mm CHT. Tornillo 3,5x12mm CHT. Screw 3,5x12mm CHT.
H  Cavilha 8x25mm Cinta 8x25mm Dowel 8x25mm	I  Fixador de fundos Fijador de fondos Bottom fixer	J  Prego 12x12mm Anelado Clavo 12x12mm Anillado Ringed Nails 12x12mm	K  Prego 10x10mm Clavo 10x10mm Nail 10x10mm	L  Parafuso minifix Tornillo minifix Minifix bolt	M  Tambor minifix Tambor minifix Minifix drum	N  Porca cilíndrica Tuerca cilíndrica Cylindrical nut
O  Conector de Haste Dupla Conector de vástago doble Double Stem Connector	P  Distanciador de corredeira Distanciador de deslizamiento Sliding spacer	Q  Cantoneira plástica Cantонера plástica Plastic angle brackets	R  Calço Removível p/ Dobradilha 45° Calzón extraíble para bisagra 45° 45° Hinged Removable Cover	S  Dobradilha 35mm 45° Amortecimento Bisagra 35mm 45° Amortiguación Hinge 35mm 45° Damping	T  Corredeira telescópica Diapositivas telescópicas Telescopic slides	U  Suporte cabideiro Soporte de percha Coat hanger support
V  Puxador Aleno Fit Alumínio Mango de alumínio Aleno Fit Aleno Fit Aluminum Handle	W  Kit Led Kit Led Led Kit	X  Cabideiro Alum. 628mm Alum. 628mm percha Alum. coat hanger 628mm	Y  Perfil "I" 489mm Perfil "I" 489mm Profile "I" 489mm	Z  Perfil "I" 560mm Perfil "I" 560mm Profile "I" 560mm	AA  Sapata "L" 16x20mm Zapata "L" 16x20mm "L" shoe 16x20mm	AB  Parafuso União Metal Tornillo Unión Metal Metal Union Screw
AC  Sachê de cola Bolsa de pegamento Glue bag	AD  Adesivo tampa parafuso 10mm Adhesivo tapón de tornillo 10mm Bolt cover adhesive 10mm	AE  Adesivo tampa parafuso 17mm Adhesivo tapón de tornillo 17mm Bolt cover adhesive 17mm	AF  Cavilha Plástica 8x29mm Cinta Plástico 8x29mm Plastic Dowel 8x29mm	AG  Parafuso 3,0x30mm CHT. Tornillo 3,0x30mm CHT. Screw 3,0x30mm CHT.	AH  Etiqueta resinada Henn Etiqueta resinada Henn Henn resin label	AI  Parafuso 3,5x22mm CHT. Tornillo 3,5x22mm CHT. Screw 3,5x22mm CHT.

HENN

Ind. e Com. de Móveis Henn
Mondai - SC - Brasil

+55 49 3674.3500

@moveishenn
www.henn.com.br

INSTRUÇÕES DE MONTAGEM

INSTRUCCIONES DE MONTAJE
ASSEMBLY INSTRUCTIONS

Roupeiro 2 Portas Deslizantes Seletto | Armario 2 Puertas Deslizadores Seletto | Wardrobe 2 Sliding Doors Seletto

c MC10-133 Areia HP

c MC10-184 Areia HP/Jequitibá

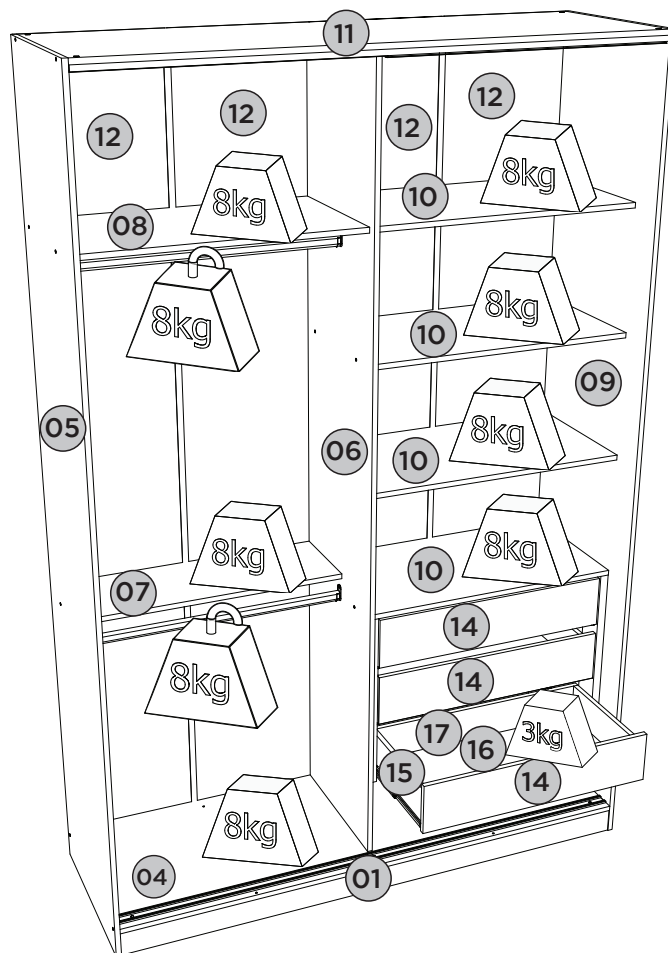
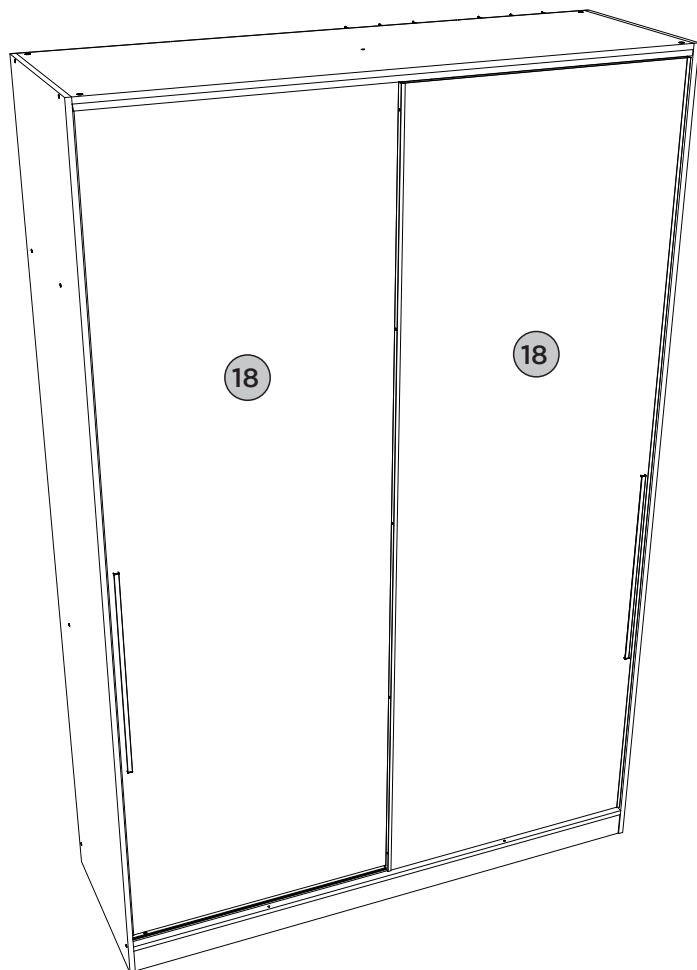

Pesos máximos recomendados com carga distribuída
Peso máximo recomendado con la carga distribuida
Recommended maximum weights with evenly distributed.

Requisitos para montagem Requisitor para la montaje Assembly Requirements

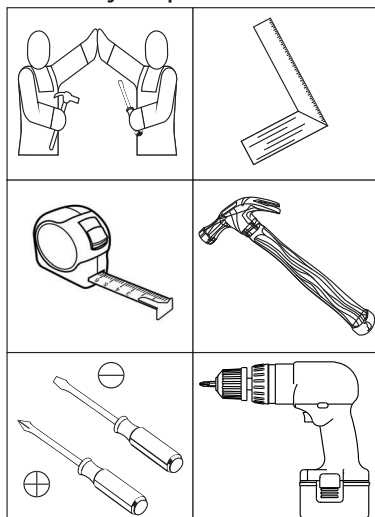

Imagens meramente ilustrativas
Imágenes meramente ilustrativas
Images for illustration only

AVISO

Para limpeza de seu móvel, use uma flanela seca ou umedecida, e não utilize produtos químicos que possam danificar seu produto.

SISTEMA DE MONTAGEM

O sistema de montagem dos produtos, funciona de acordo com a ordem crescente dos números indicados no desenho. Ex: 01, 02, 03, 04... até a conclusão da montagem.

ADVERTENCIA

Para limpieza de su móvil, use una flanela seca o húmeda, y no utilice productos químicos que puedan dañar su producto.

SISTEMA DE MONTAJE

El sistema de montaje de los productos funciona de acuerdo con el orden creciente de los números indicados en el dibujo. Ej.: 01, 02, 03, 04... hasta la conclusión del montaje.

NOTICE

To clean your furniture, use a dry or wet cloth, and do not use chemicals that may damage your product.

ASSEMBLY SYSTEM

The products' assembly system works according to the increasing order of the indicated numbers. For example: 01, 02, 03, 04 ... to the end of the assembly.

1

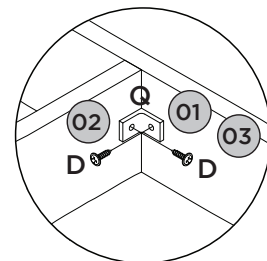
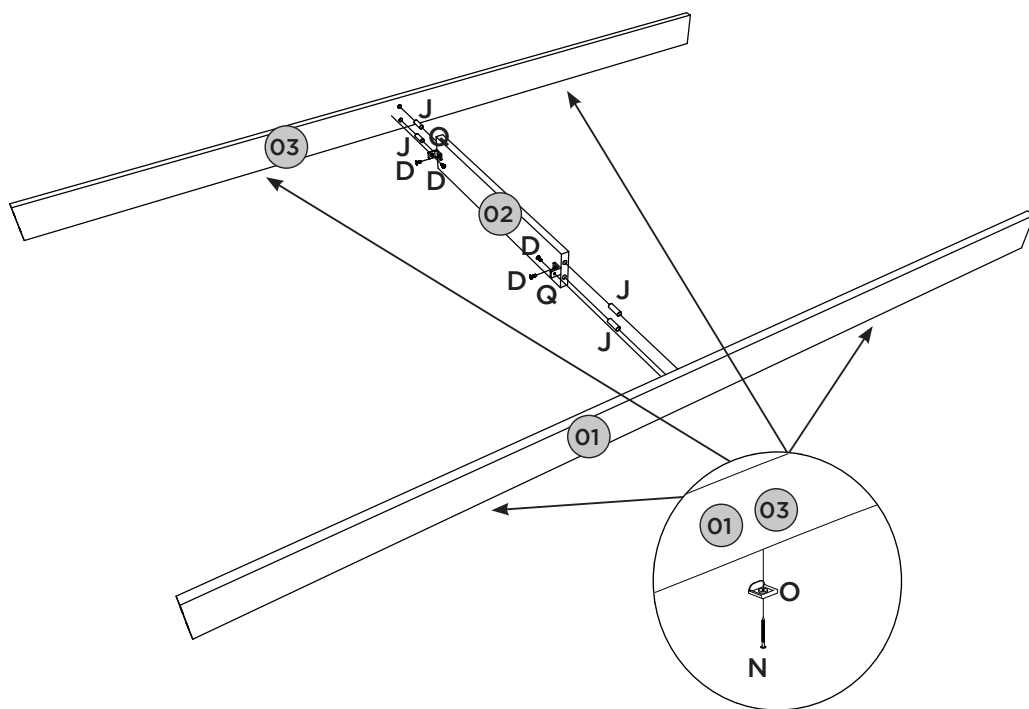

2

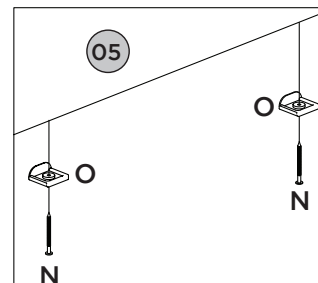
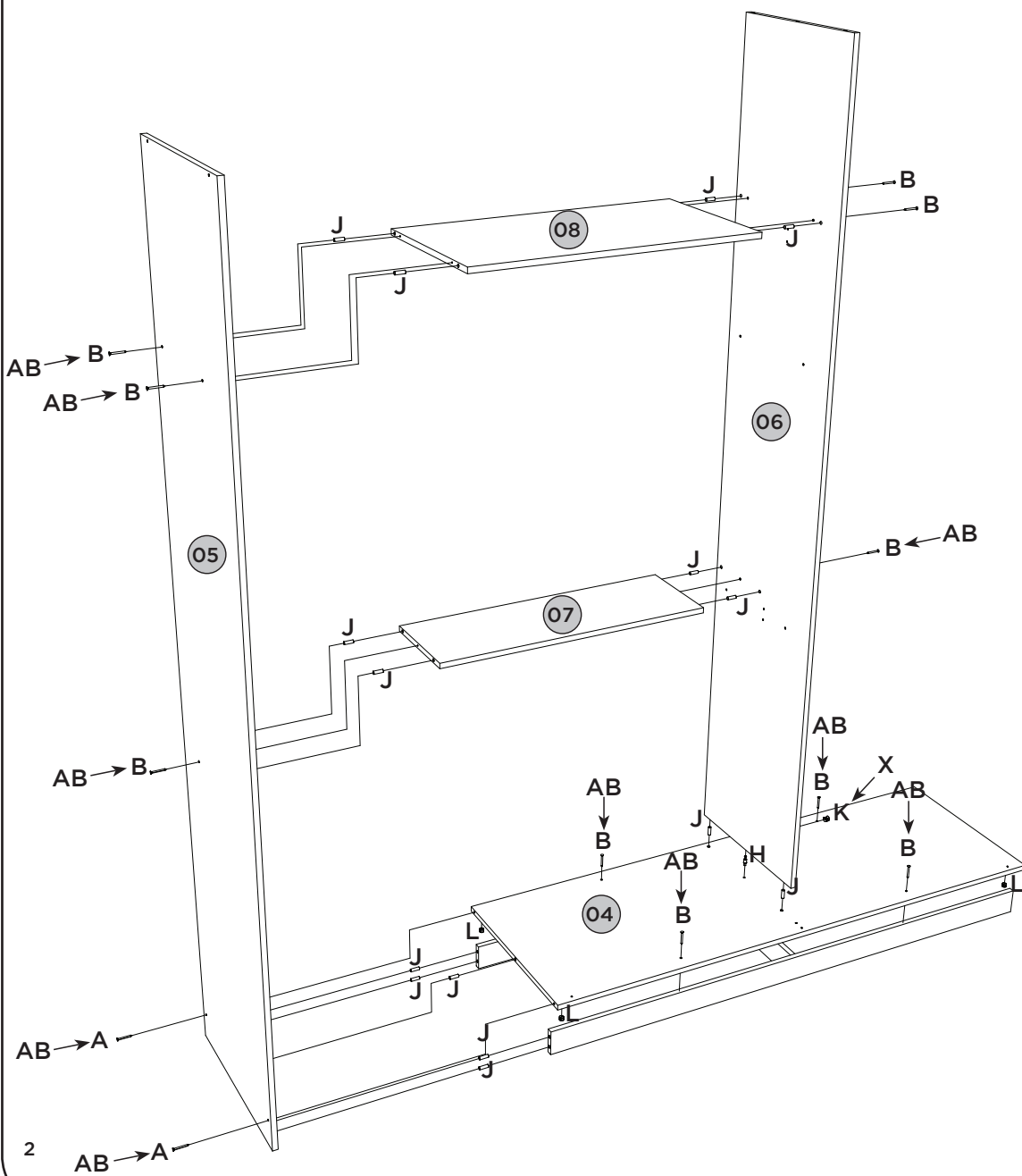

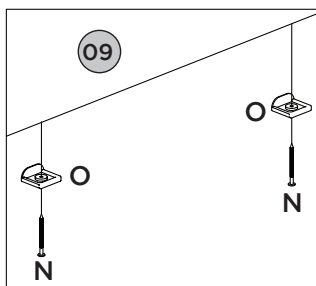
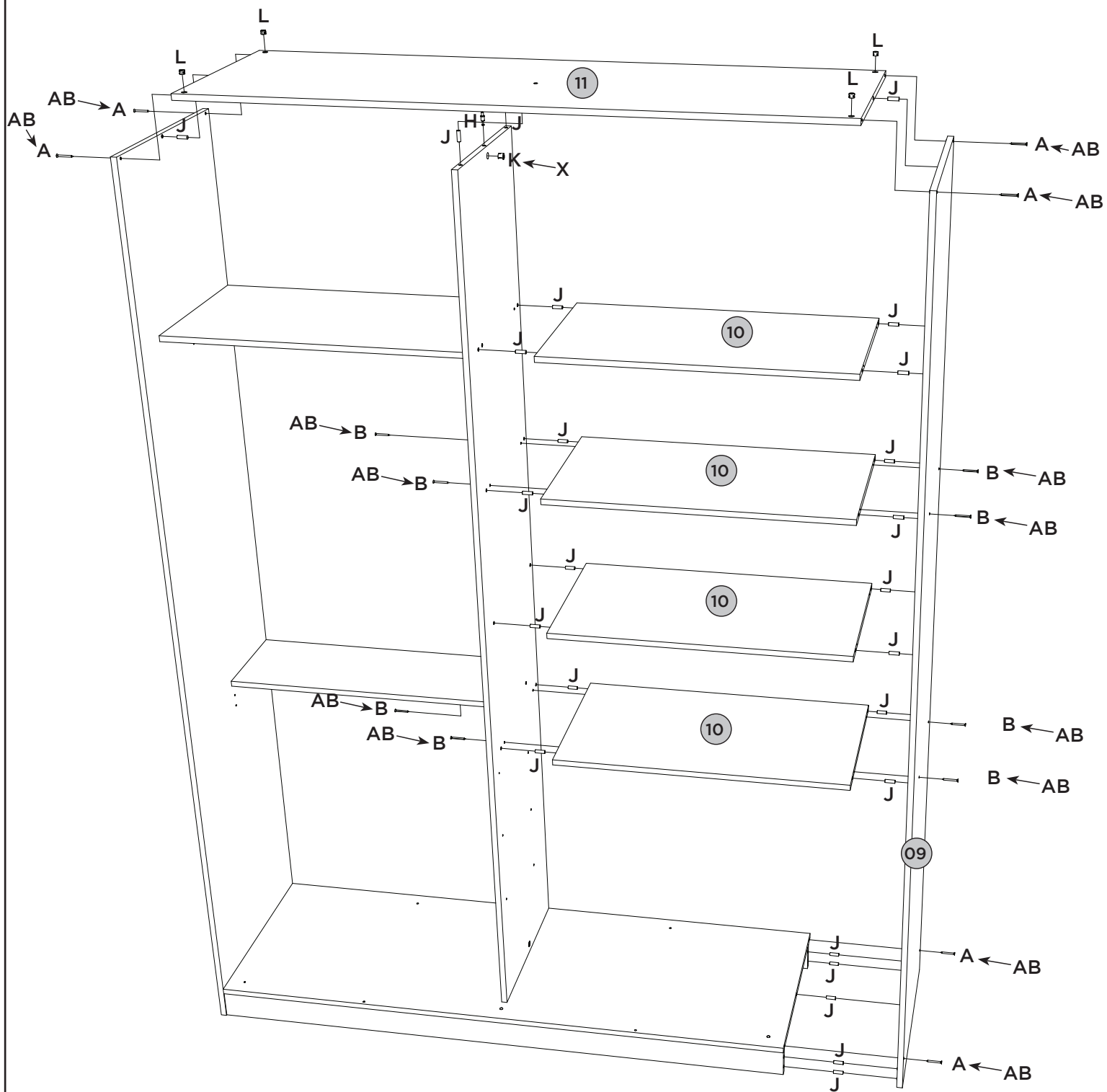

4 Fixar os pregos (M) a uma distância de 100mm de um para outro.

Fijar el clavo (M) a una distancia un 100mm a otro.

Fix the nails (M) at a distance of 100mm from one to another.

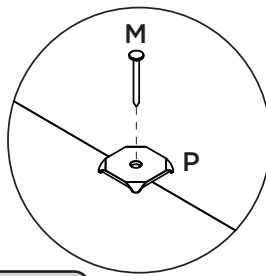

Os freios devem ser encostados a lateral.

Los frenos deben ser apoyados en el lateral.

The brakes should be against the side.

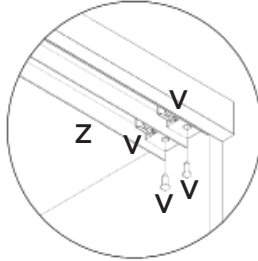
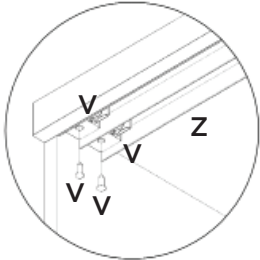

Colocação do freio esq. (V) deve ser colocado no espaço de trás do trilho superior (Z).

Colocação do freio dir. (V) deve ser colocado no espaço de frente do trilho superior (Z).

Colocación de frenos izq. (V) Debe ser colocado en espacio de nuevo carril superior (Z).

Colocación de frenos der. (V) Debe ser colocado en espacio de nuevo carril superior (Z).

Placing the left brake (V) should be placed in the rear space of the upper rail (Z).

Placing the right brake (V) should be placed in the front track of the upper track (Z).

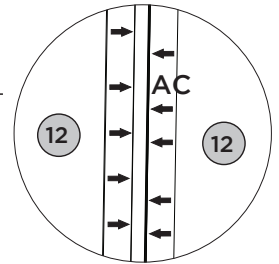
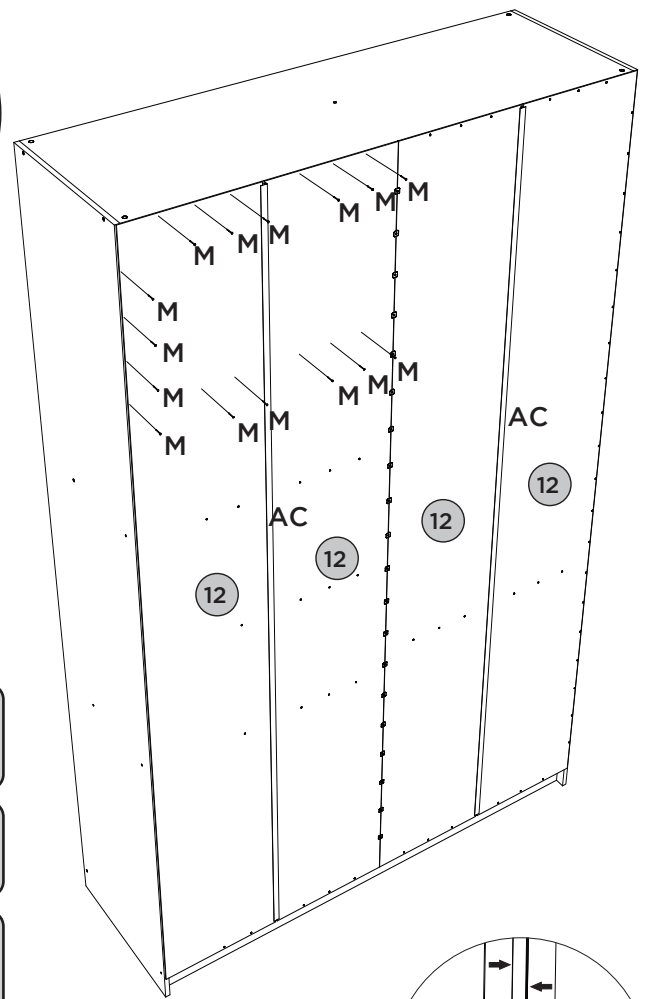

5

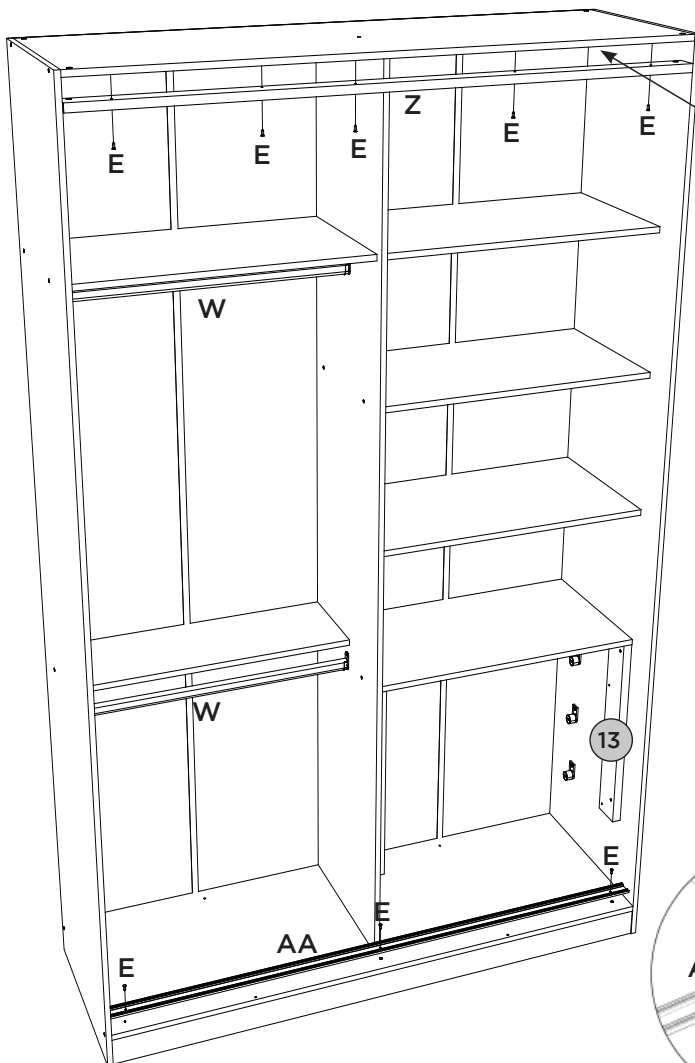

O trilho Superior (Z) deverá ser alinhado com a borda da frente do tampo (11).

El carril superior (Z) debe estar alineado con el borde frontal de la superficie de trabajo (11).

The Top Rail (Z) should be aligned with the front edge of the top (11).

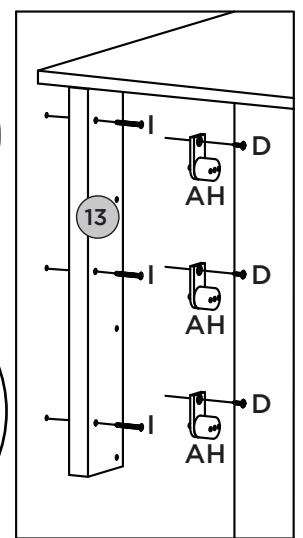
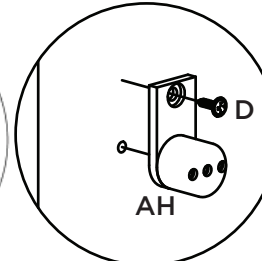
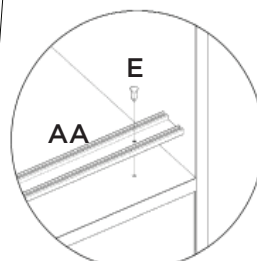
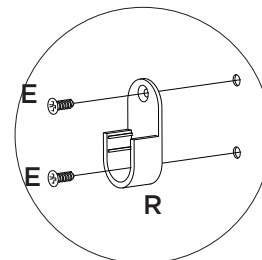

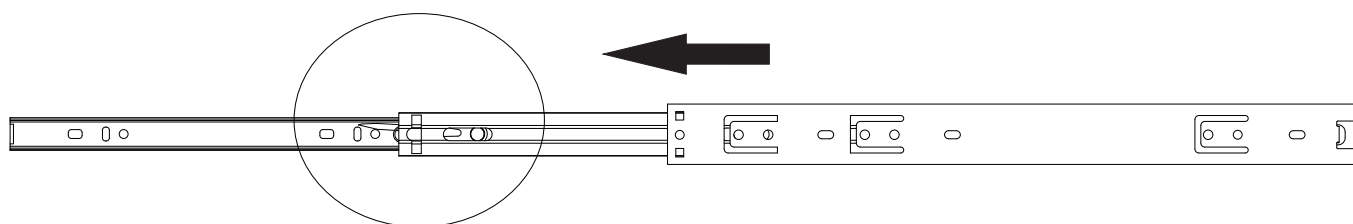
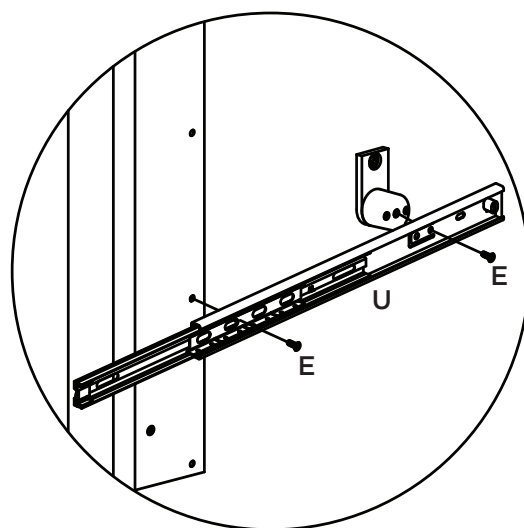
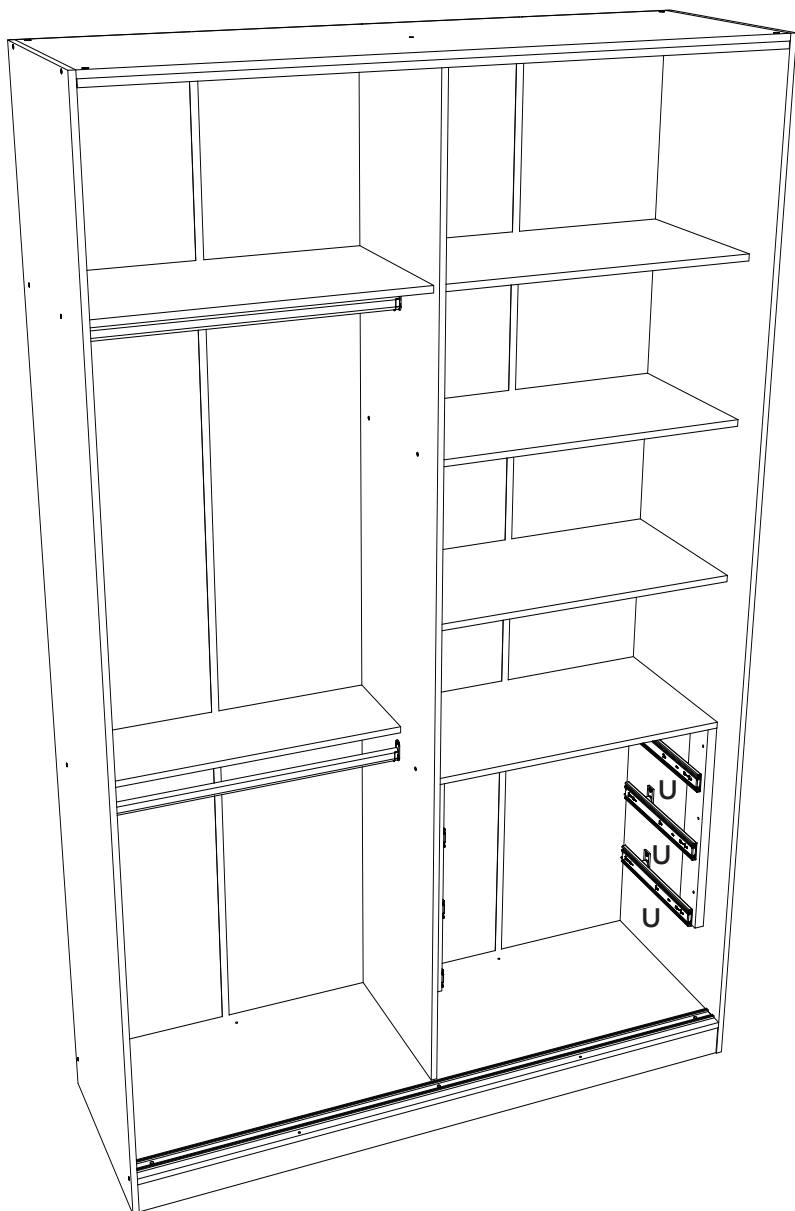

Para a desmontagem da corrediça siga a instrução ao lado.

Para el desmontaje seguimiento de diapositivas la instrucción siguiente a.

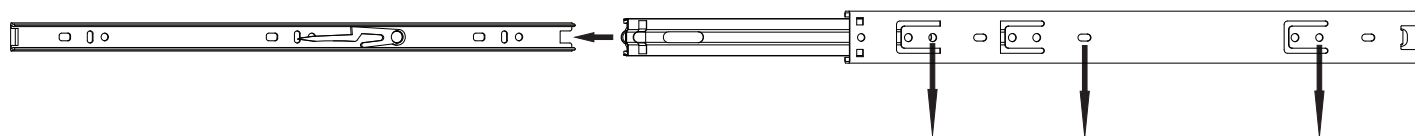
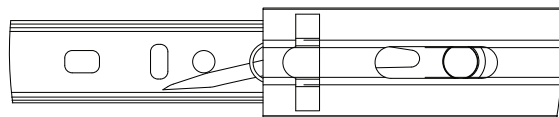
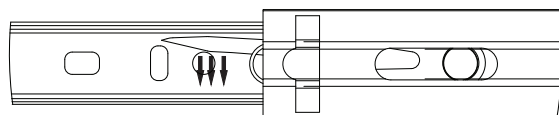

Fixar as corrediças nessas furações

Fijar las diapositivas de estos agujeros

7

Fazer furação passante para fixar os puxadores, utilizando as pré marcações existentes nas portas.

Taladre agujeros para fijar las manijas, utilizando las marcas previas en las puertas.

Drill through holes to fix the handles, using the pre-markings on the doors.

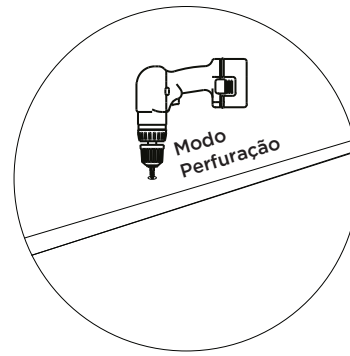

Porta 12mm
Puerta 12mm
Door 12mm

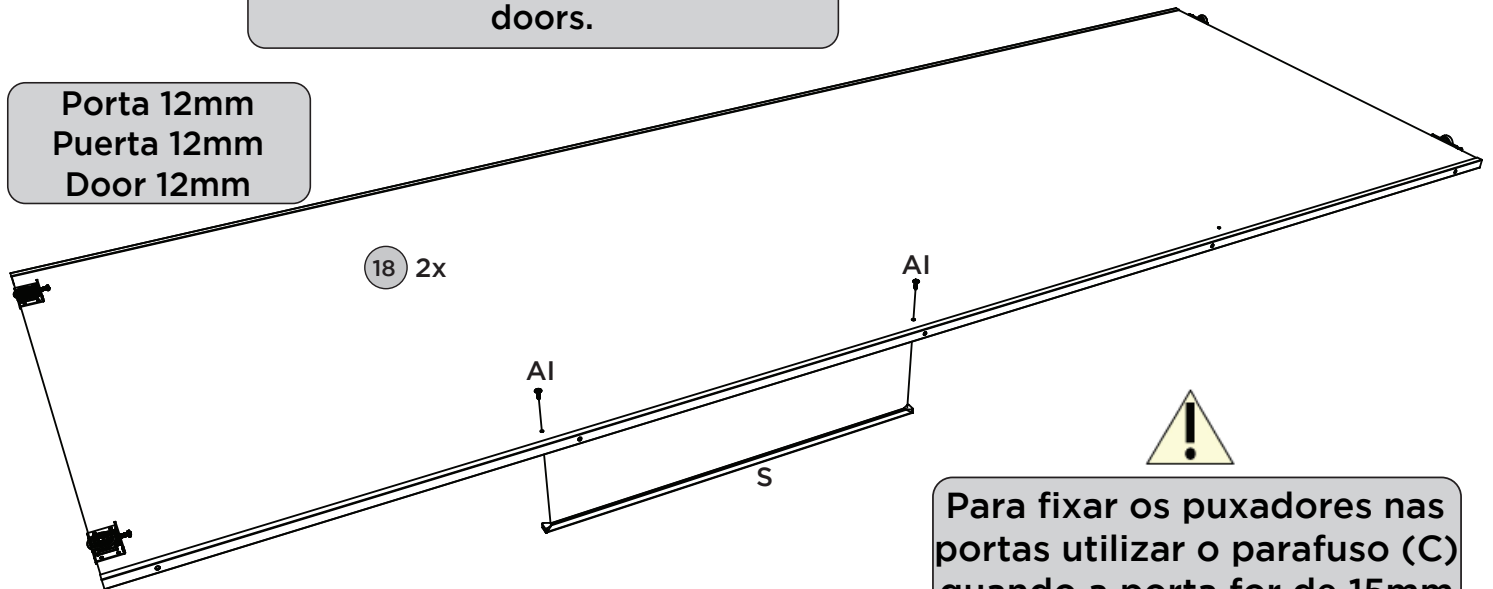

Para fixar os puxadores nas portas utilizar o parafuso (C) quando a porta for de 15mm e o parafuso (AI) quando a porta for de 12mm.

Para fijar las manijas en las puertas, utilice el tornillo (C) cuando la puerta sea de 15 mm y el tornillo (AI) cuando la puerta sea de 12 mm.

To fix the handles on the doors, use the screw (C) when the door is 15mm and the screw (AI) when the door is 12mm.

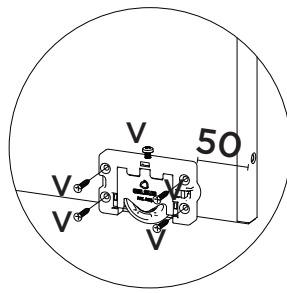
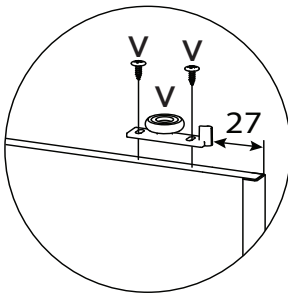

Porta 15mm
Puerta 15mm
Door 15mm

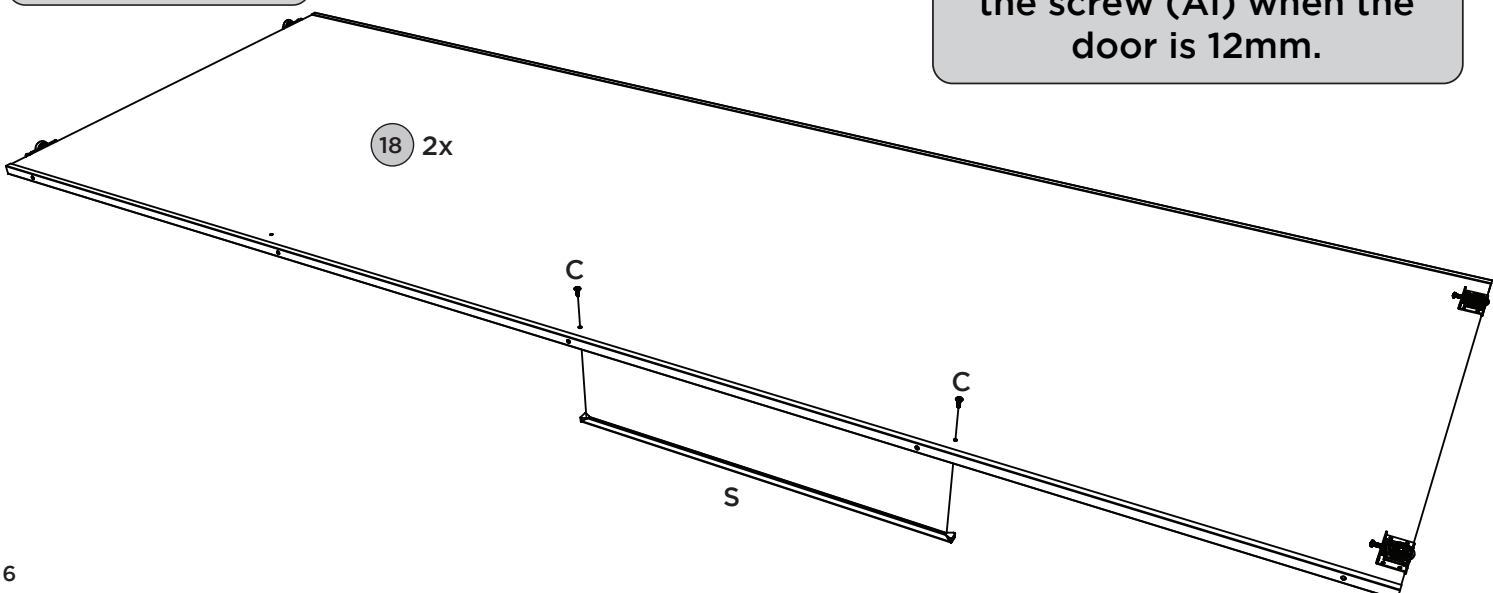

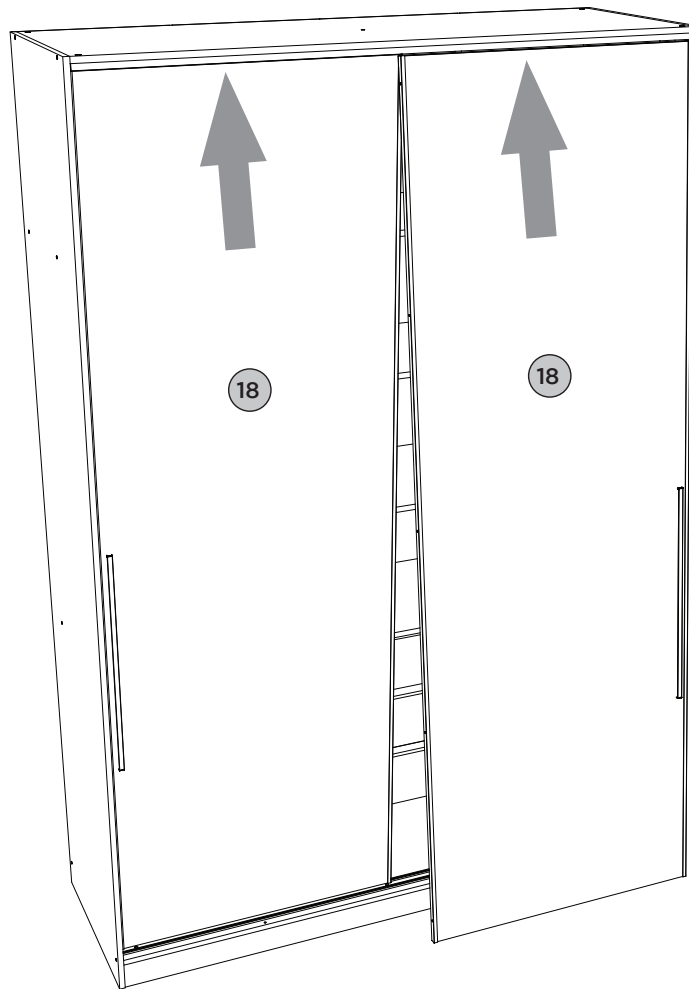

10 Montagem gaveta 3x. Montaje del cajón 3x. Mounting drawer 3x.

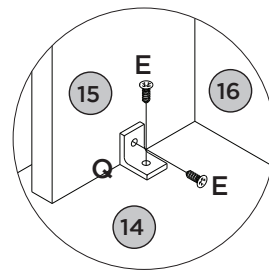
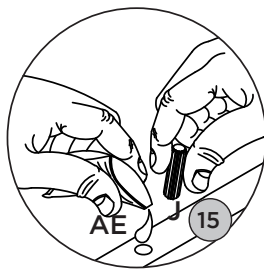
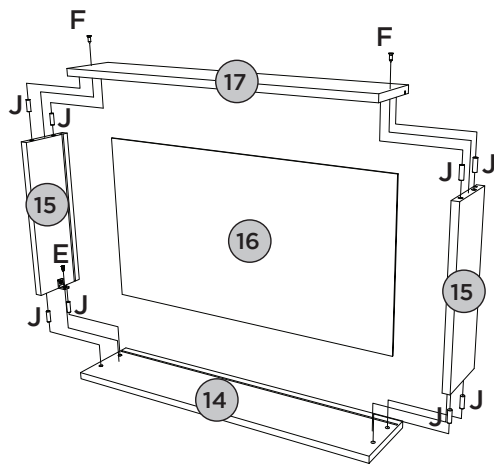

A corredeira (U) deverá ser alinhada com a parte de baixo do lado de gaveta (15)

La corredera (U) debe ser alineada con la parte de por el lado del cajón (15)

The slide (U) should be aligned with the underside of the drawer side (15)

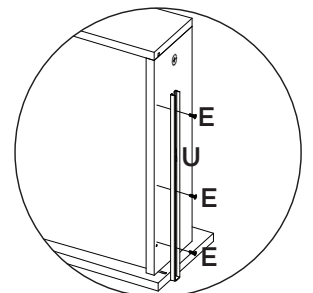
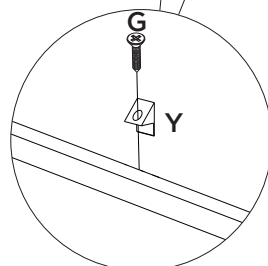
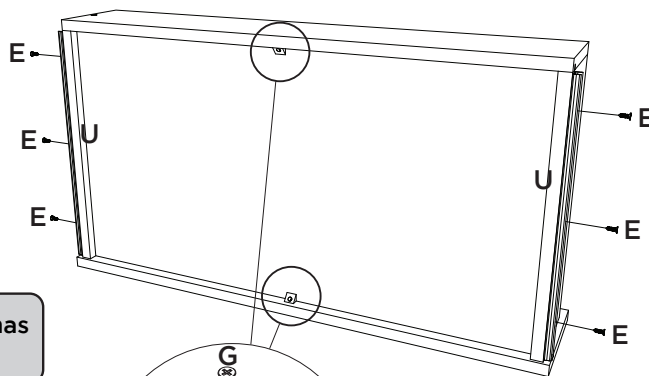
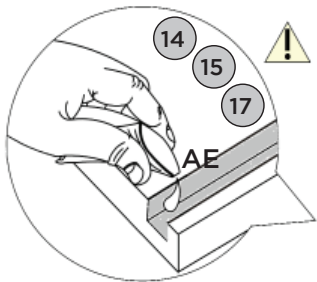

Utilizar o Sachê de cola (AE) nas cavilhas (J) e nos frisos das gavetas.















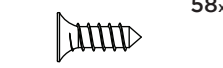

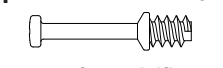







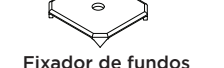



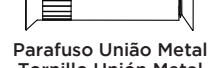



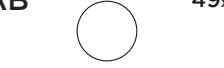

El uso de pegamento de paquetes (AE) sobre los pasadores (J) y las cuentas de los cajones.

Use the glue sachet (AE) on the pegs (J) and on the frieze of the drawers.

Lista de Peças | Lista de piezas | List of parts

Item	Caixa Caja Box	Qty Ctd Qty	Descrição Descripción Description	Medidas (mm) Dimensions (mm) Size (measurements) (mm)
01	1/3	01	Rodapé Frontal Rodapié Frontal Front baseboard	1555x73x15
02	1/3	01	Travessa do rodapé Carril pie Baseboard crosspiece	455x73x15
03	1/3	01	Rodapé Traseiro Rodapié trasero Rear baseboard	1555x73x15
04	1/3	01	Base Base Base	1555x520x15
05	2/3	01	Lateral esquerda Lateral izquierda Left side	2400x520x15
06	2/3	01	Divisão División Division	2297x450x15
07	1/3	01	Prateleira do varão Estantería hombre Rod shelf	770x250x15
08=10	1/3	01	Prateleira Estante Shelf	770x420x15
09	2/3	01	Lateral direita Lateral derecha Right side	2400x520x15
10=08	1/3	04	Prateleira Estante Shelf	770x420x15
11	1/3	01	Tampo Tapa Top	1555x520x15
12	2/3	04	Fundo Fondo Bottom	2327x391x3
13	1/3	02	Ripa lateral Lado ripa Lateral clamp	530x80x25
14	1/3	03	Frete de gaveta Frete de cajón Front of drawer	712x152x15
15	1/3	06	Lado de gaveta Lado del cajón Side of drawer	350x122x15
16	2/3	03	Fundo de gaveta recortado Fondo del cajón recortado Cropped drawer bottom	676x361x3
17	1/3	03	Ripa de trás Malla detrás Rear lath	695x122x15
18	3/3	02	Porta Deslizante Puerta corrediza Sliding door - Areia HP	2267x783x12
18	3/3	02	Porta Deslizante Puerta corrediza Sliding door - Jequitibá	2267x783x15

Ferragens | Herrajes | Hardware

A	08x	B	18x	C	04x	D	10x	E	58x	F	06x
											
Parafuso 4,5x50mm CHT. Tornillo 4,5x50mm CHT. Screw 4,5x50mm CHT.		Parafuso 3,5x40mm CHT. Tornillo 3,5x40mm CHT. Screw 3,5x40mm CHT.		Parafuso 3,5x20mm FLA. Tornillo 3,5x20mm FLA. Screw 3,5x20mm FLA.		Parafuso 3,5x14mm FLA. Tornillo 3,5x14mm FLA. Screw 3,5x14mm FLA.		Parafuso 3,5x12mm CHT. Tornillo 3,5x12mm CHT. Screw 3,5x12mm CHT.		Parafuso 3,0x30mm CHT. Tornillo 3,0x30mm CHT. Screw 3,0x30mm CHT.	
G	06x	H	02x	I	06x	J	68x	K	02x	L	08x
											
Parafuso 3,0x16mm CHT. Tornillo 3,0x16mm CHT. Screw 3,0x16mm CHT.		Parafuso minifix Tornillo minifix Minifix bolt		Parafuso 4,0x35mm CHT. Tornillo 4,0x35mm CHT. Screw 4,0x35mm CHT.		Cavilha 8x25mm Cinta 8x25mm Dowel 8x25mm		Tambor minifix Tambor minifix Minifix drum		Porca cilíndrica Tuerca cilíndrica Cylindrical nut	
M	128x	N	06x	O	06x	P	22x	Q	08x	R	04x
											
Prego 10x10mm Clavo 10x10mm Nail 10x10mm		Prego 12x12mm Anelado Clavo 12x12mm Anillado Ringed Nails 12x12mm		Sapata "L" 16x20mm Zapata "L" 16x20mm "L" shoe 16x20mm		Fixador de fundos Fijador de fondos Bottom fixer		Cantoneira plástica Cantонера plástica Plastic angle brackets		Suporte cabideiro Soporte de percha Coat hanger support	
S	02x	T	05x	U	03x	V	01x	W	02x	X	02x
											
Puxador Aleno PC Alumínio Mango de aluminio Aleno PC Aleno PC Aluminum Handle		Parafuso União Metal Tornillo Unión Metal Metal Union Screw		Corrediça telescópica Corredera telescópica Telescopic slide		Kit Rodizio CM 110 Silence com Rolamento 2Pis Kit Ruedas CM 110 Silence con Cojinete 2Pis Caster Kit CM 110 Silence with Bearing 2Pis		Cabideiro Alum. 762mm Alum. 762mm percha Alum. coat hanger 762mm		Adesivo tapa parafuso 17mm Adhesivo tapón de tornillo 17mm Bolt cover adhesive 17mm	
Y	06x	Z	01x	AA	01x	AB	49x	AC	02x	AD	01x
											
Cantoneira suporte triangular Cantонера soporte triangular Triangle support angle		Trilho Superior 1553mm Carril superior 1553mm Top Rail 1553mm		Trilho Inferior 1553mm Carril Inferior 1553mm Lower Rail 1553mm		Adesivo tapa parafuso 10mm Adhesivo tapón de tornillo 10mm Bolt cover adhesive 10mm		Perfil H 2312mm Perfil H 2312mm H profile 2312mm		Etiqueta resinada Henn Etiqueta resinada Henn Henn resin label	
AE	02x	AF	02x	AG	04x	AH	06x	AI	04x		
											
Sachê de cola Bolsa de pegamento Glue bag		Giz de correção Tiza de corrección Chalk of correction		Perfil Anti-empeno 2299mm Perfil anti-empeno 2299mm Anti-warp profile U 2299mm		Distanciador de corrediça Distanciador de deslizamiento Sliding spacer		Parafuso 3,5x18mm FLA. Tornillo 3,5x18mm FLA. Screw 3,5x18mm FLA.			

A ferragem "AG" só será usada em caso de pedido de assistência técnica, pois o perfil antiempeno "U" já vem montado nas portas de fábrica.

El hardware "AG" sólo se utilizará en caso de solicitud de asistencia técnica, ya que el perfil antiempeno "U" ya viene montado en las puertas de fábrica.

The "AG" hardware will only be used in the event of a service request, as the "U" anti-pilling profile is already installed on the factory doors.

A união (T) deve ser usada somente quando este módulo for acoplado a outro módulo componível Henn, para unir duas peças de 15mm. Caso ele seja usado separadamente, a utilização do união não se faz necessário.

La unión (T) se debe utilizar sólo cuando el módulo está acoplado a otro módulo componible Henn, para unirse a dos 15mm piezas. Si se utiliza por separado, el uso de unión no es necesario.

The union (T) should be used only when this module is coupled to another Module Henn, to join two pieces of 15mm. If it is used separately, the use of the union is not necessary.