

INSTRUÇÕES DE MONTAGEM

INSTRUCCIONES DE MONTAJE
ASSEMBLY INSTRUCTIONS

Quarto Modulado Casal 6 peças Porta Desl. Seletto

c ME09-133 Areia HP

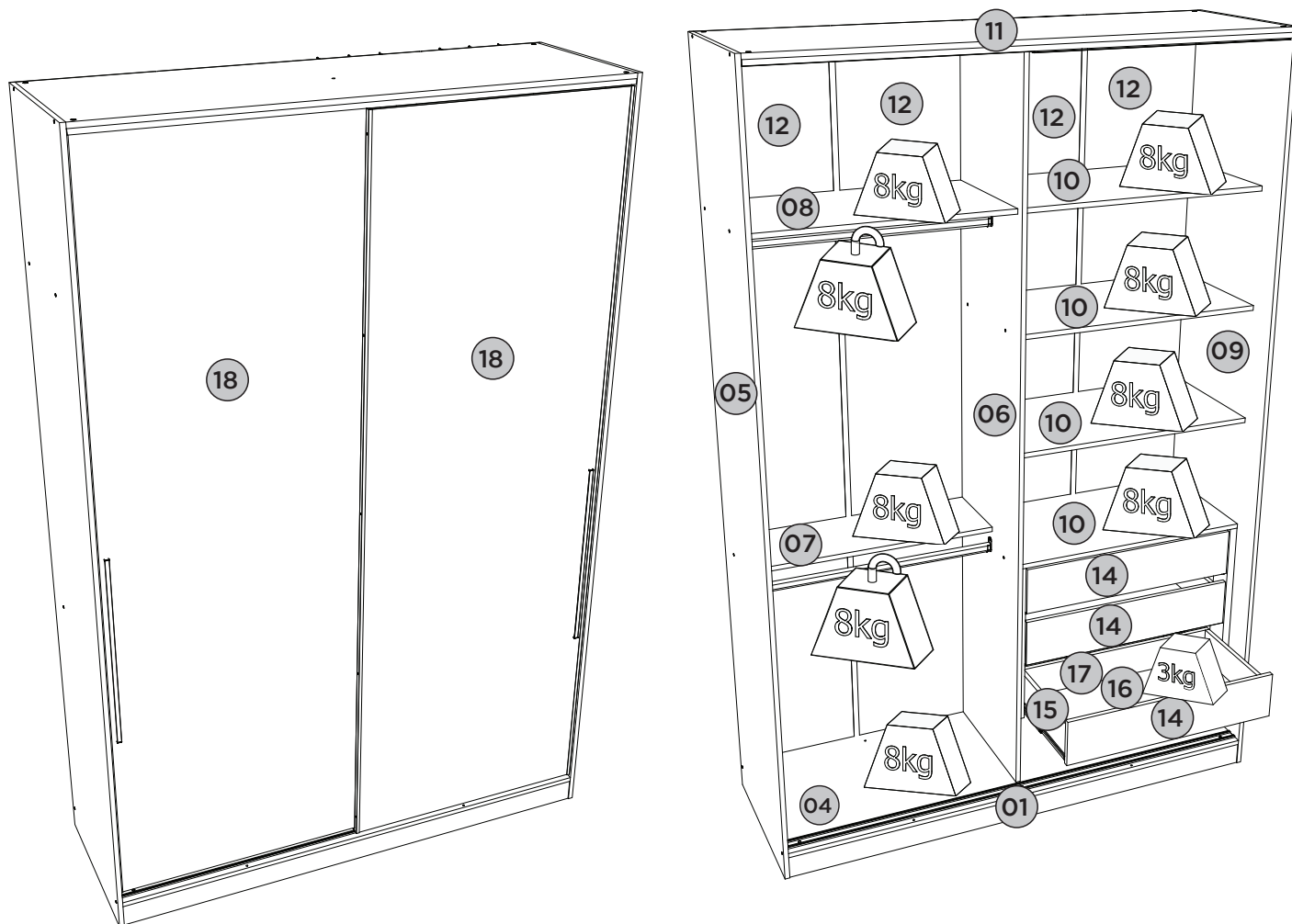

Pesos máximos recomendados com carga distribuída
Peso máximo recomendado con la carga distribuida
Recommended maximum weights with evenly distributed.

Requisitos para montagem
Requisitor para la montaje
Assembly Requirements

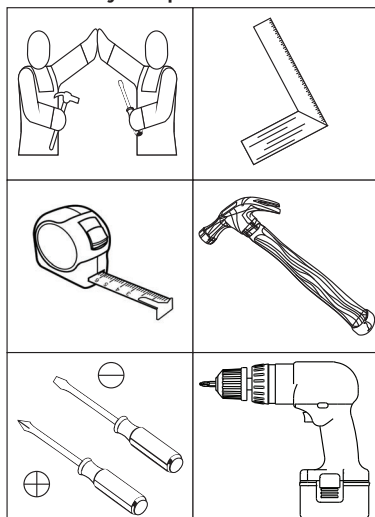

Imagens meramente ilustrativas
Imágenes meramente ilustrativas
Images for illustration only

AVISO

Para limpeza de seu móvel, use uma flanela seca ou umedecida, e não utilize produtos químicos que possam danificar seu produto.

SISTEMA DE MONTAGEM

O sistema de montagem dos produtos, funciona de acordo com a ordem crescente dos números indicados no desenho. Ex: 01, 02, 03, 04... até a conclusão da montagem.

ADVERTENCIA

Para limpieza de su móvil, use una flanela seca o húmeda, y no utilice productos químicos que puedan dañar su producto.

SISTEMA DE MONTAJE

El sistema de montaje de los productos funciona de acuerdo con el orden creciente de los números indicados en el dibujo. Ej.: 01, 02, 03, 04... hasta la conclusión del montaje.

NOTICE

To clean your furniture, use a dry or wet cloth, and do not use chemicals that may damage your product.

ASSEMBLY SYSTEM

The products' assembly system works according to the increasing order of the indicated numbers. For example: 01, 02, 03, 04 ... to the end of the assembly.

1

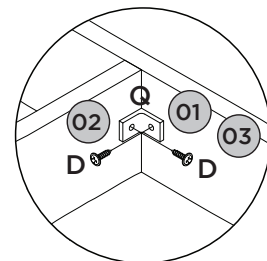
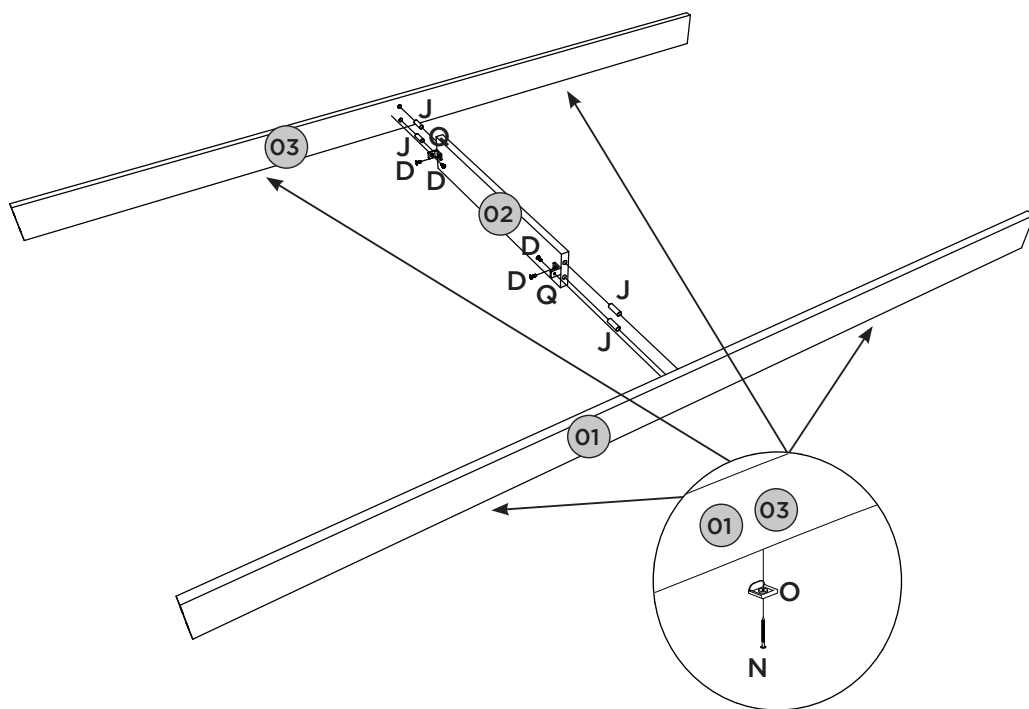

2

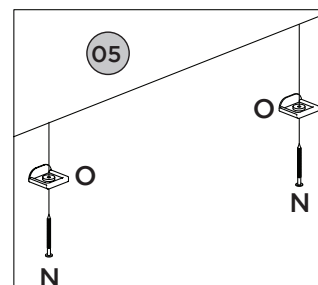
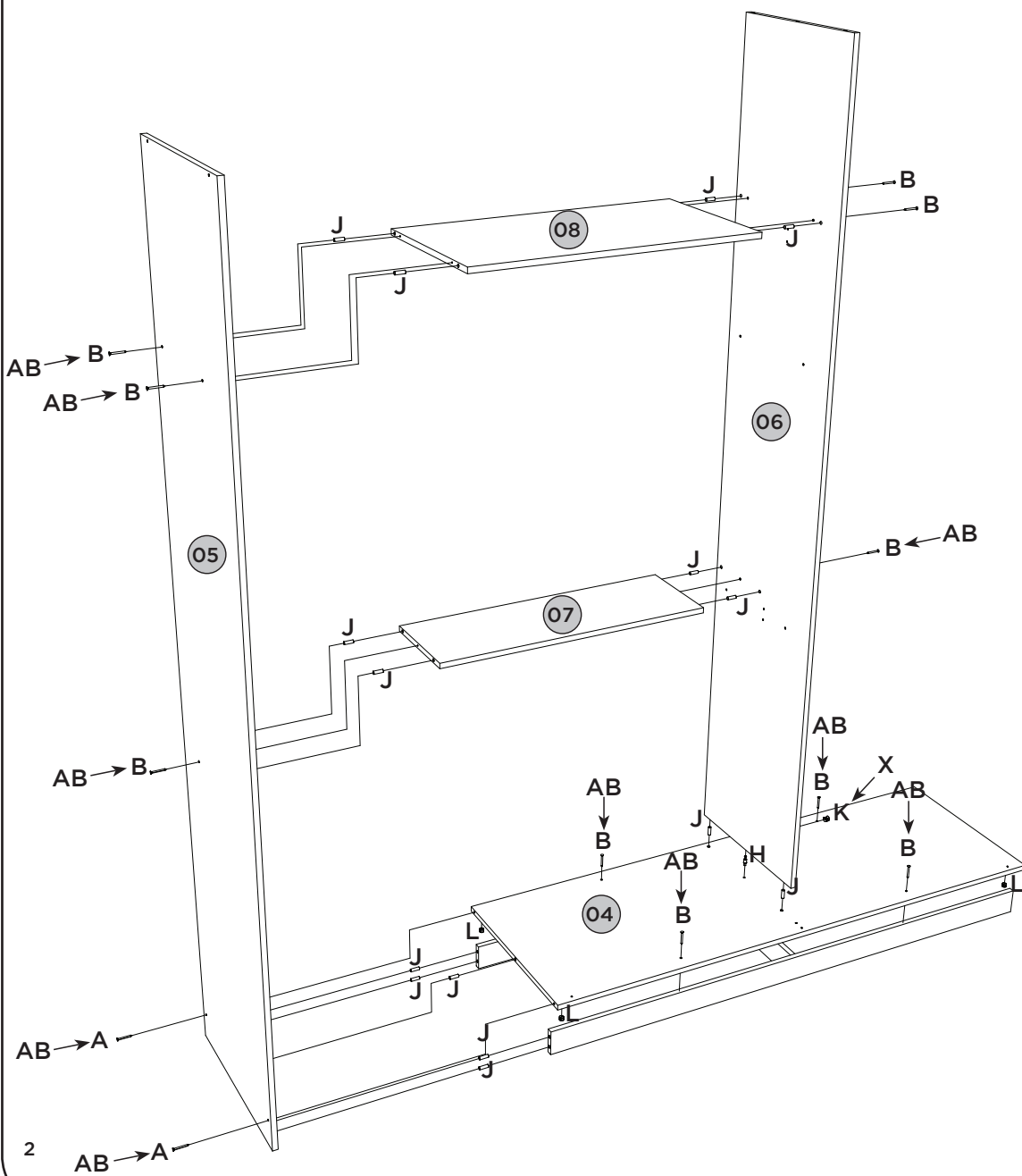

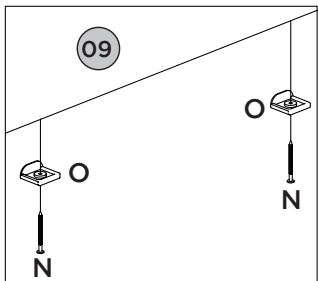
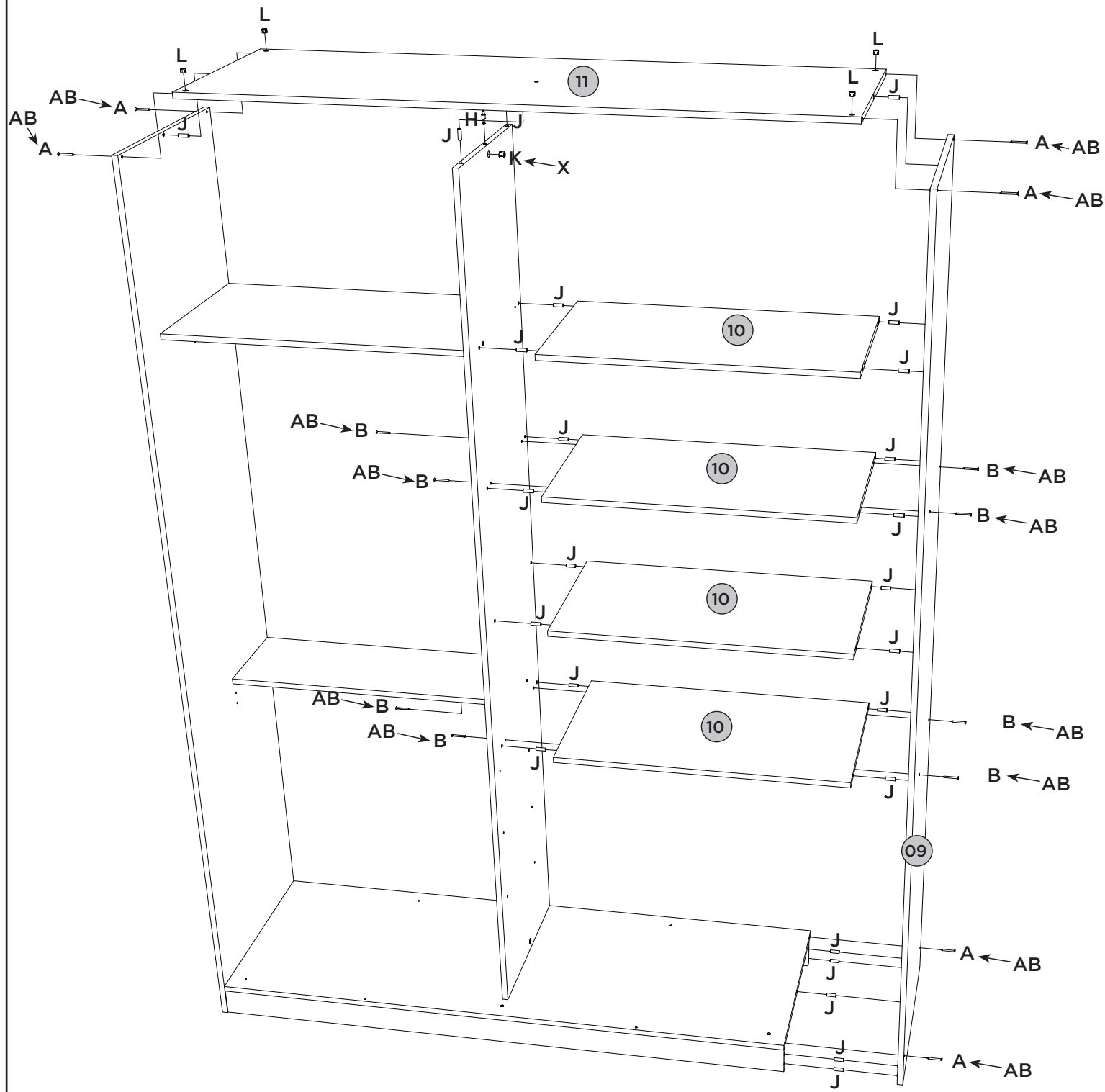

4 Fixar os pregos (M) a uma distância de 100mm de um para outro.

Fijar el clavo (M) a una distancia un 100mm a otro.

Fix the nails (M) at a distance of 100mm from one to another.

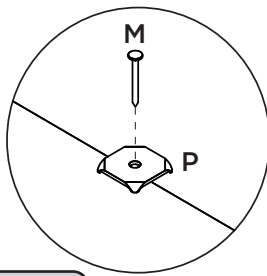

Os freios devem ser encostados a lateral.

Los frenos deben ser apoyados en el lateral.

The brakes should be against the side.

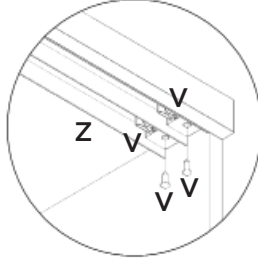
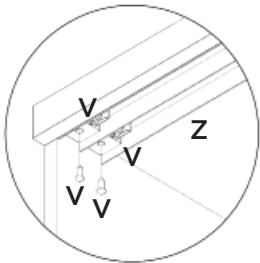

Colocação do freio esq. (V) deve ser colocado no espaço de trás do trilho superior (Z).

Colocação do freio dir. (V) deve ser colocado no espaço de frente do trilho superior (Z).

Colocación de frenos izq. (V) Debe ser colocado en espacio de nuevo carril superior (Z).

Colocación de frenos der. (V) Debe ser colocado en espacio de nuevo carril superior (Z).

Placing the left brake (V) should be placed in the rear space of the upper rail (Z).

Placing the right brake (V) should be placed in the front track of the upper track (Z).

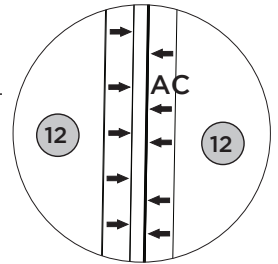
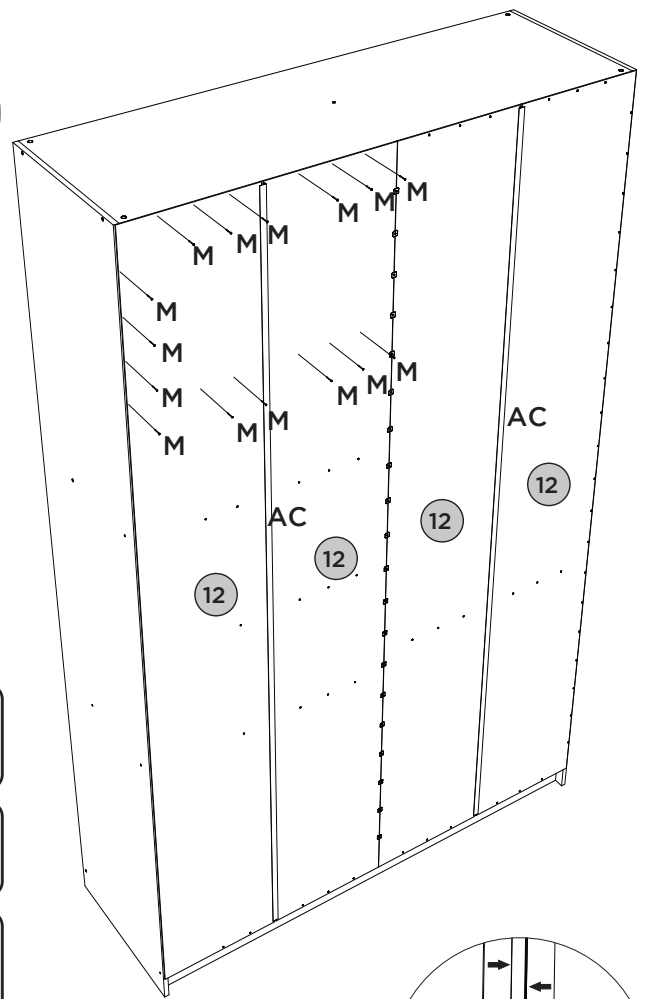

5

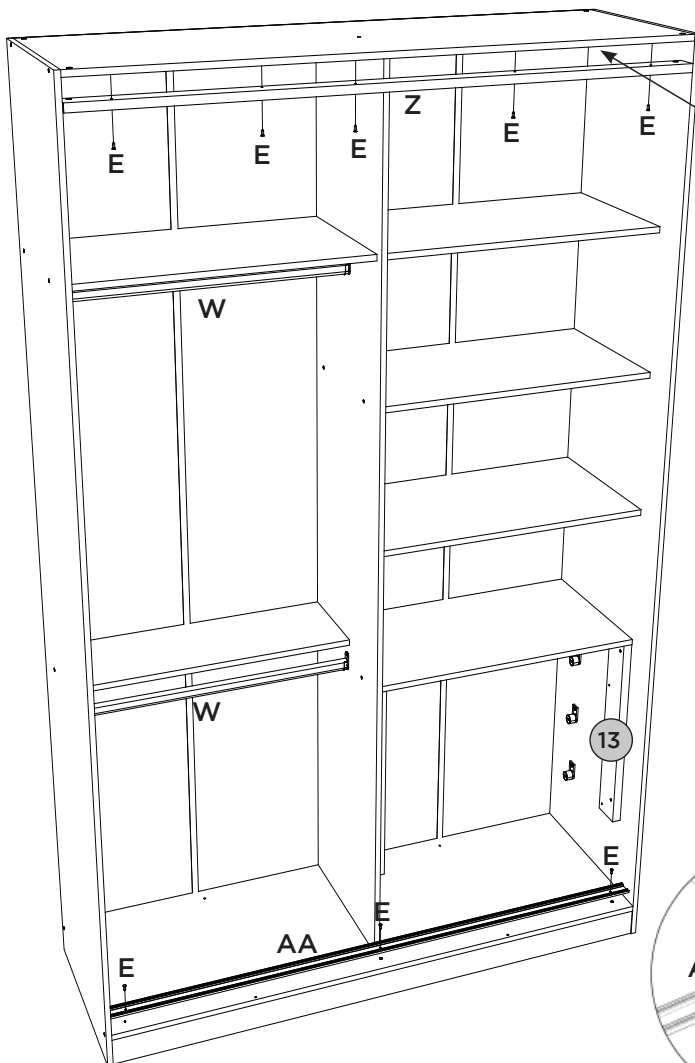

O trilho Superior (Z) deverá ser alinhado com a borda da frente do tampo (11).

El carril superior (Z) debe estar alineado con el borde frontal de la superficie de trabajo (11).

The Top Rail (Z) should be aligned with the front edge of the top (11).

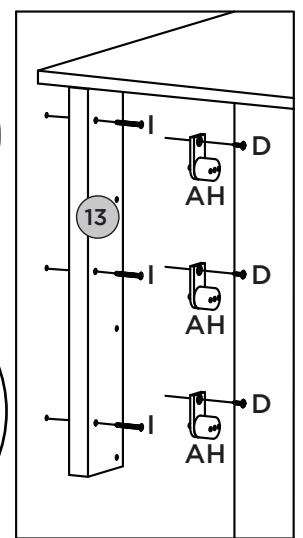
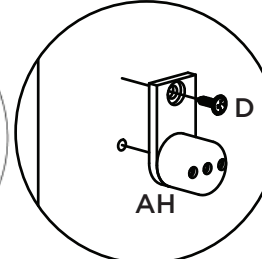
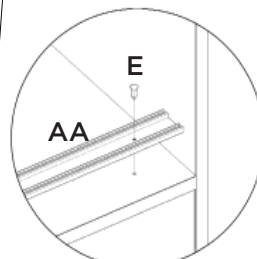
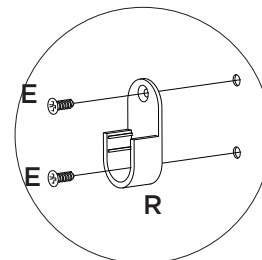

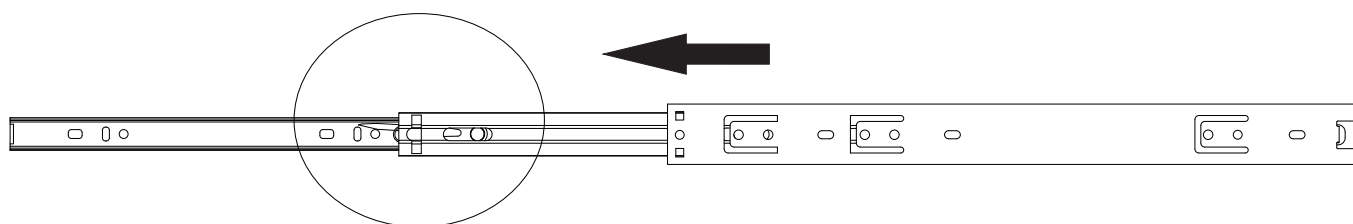
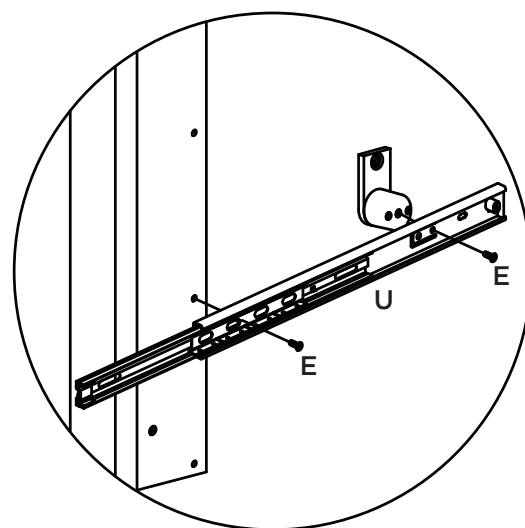
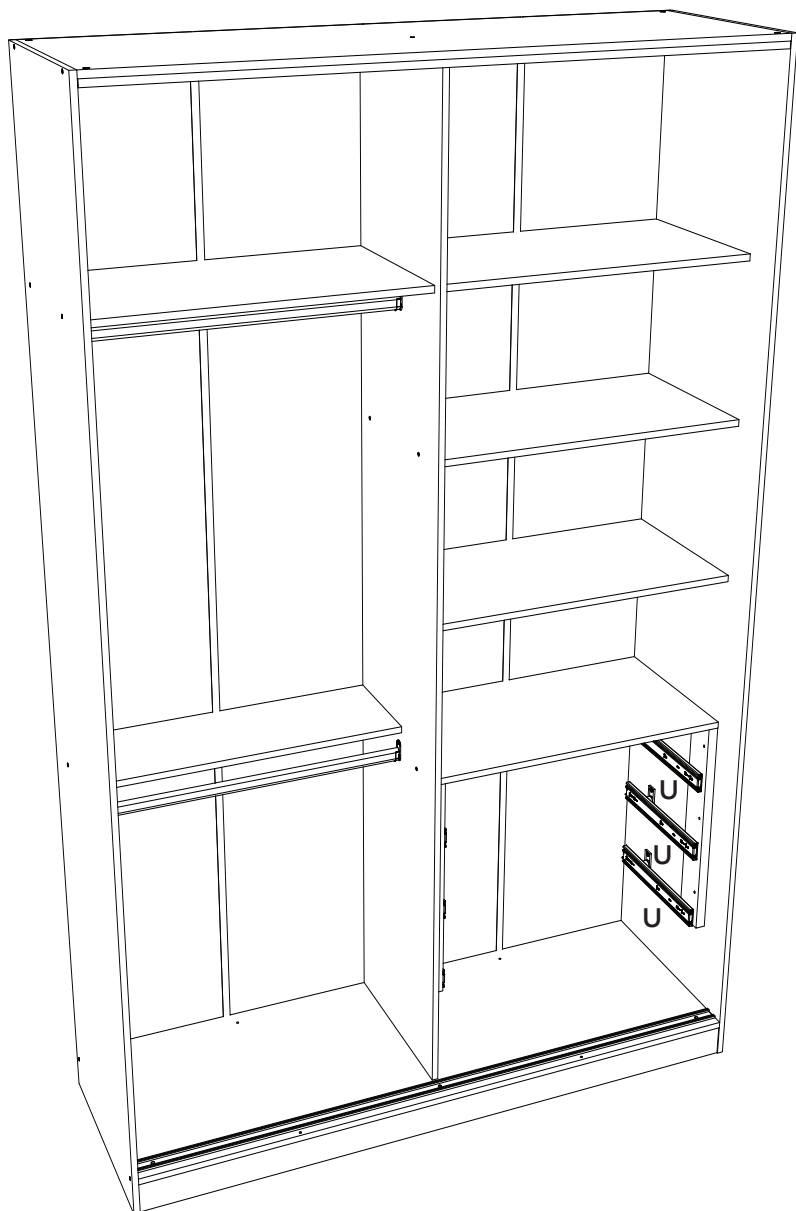

Para a desmontagem da corrediça siga a instrução ao lado.

Para el desmontaje seguimiento de diapositivas la instrucción siguiente a.

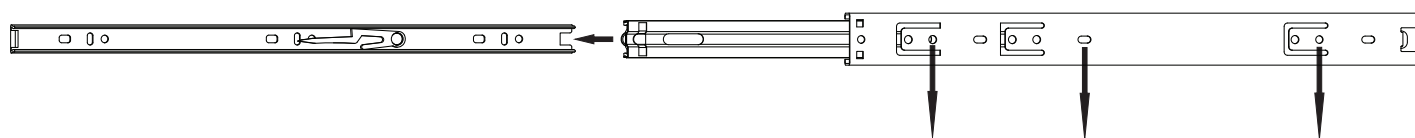
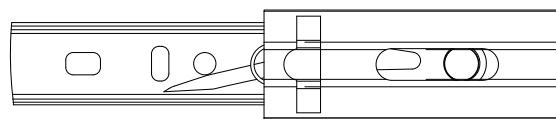
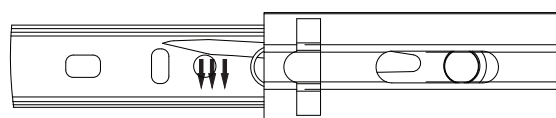

Fixar as corrediças nessas furações

Fijar las diapositivas de estos agujeros

Fazer furação passante para fixar os puxadores, utilizando as pré marcações existentes nas portas.

Taladre agujeros para fijar las manijas, utilizando las marcas previas en las puertas.

Drill through holes to fix the handles, using the pre-markings on the doors.

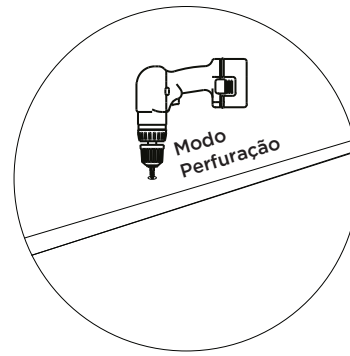

Porta 12mm
Puerta 12mm
Door 12mm

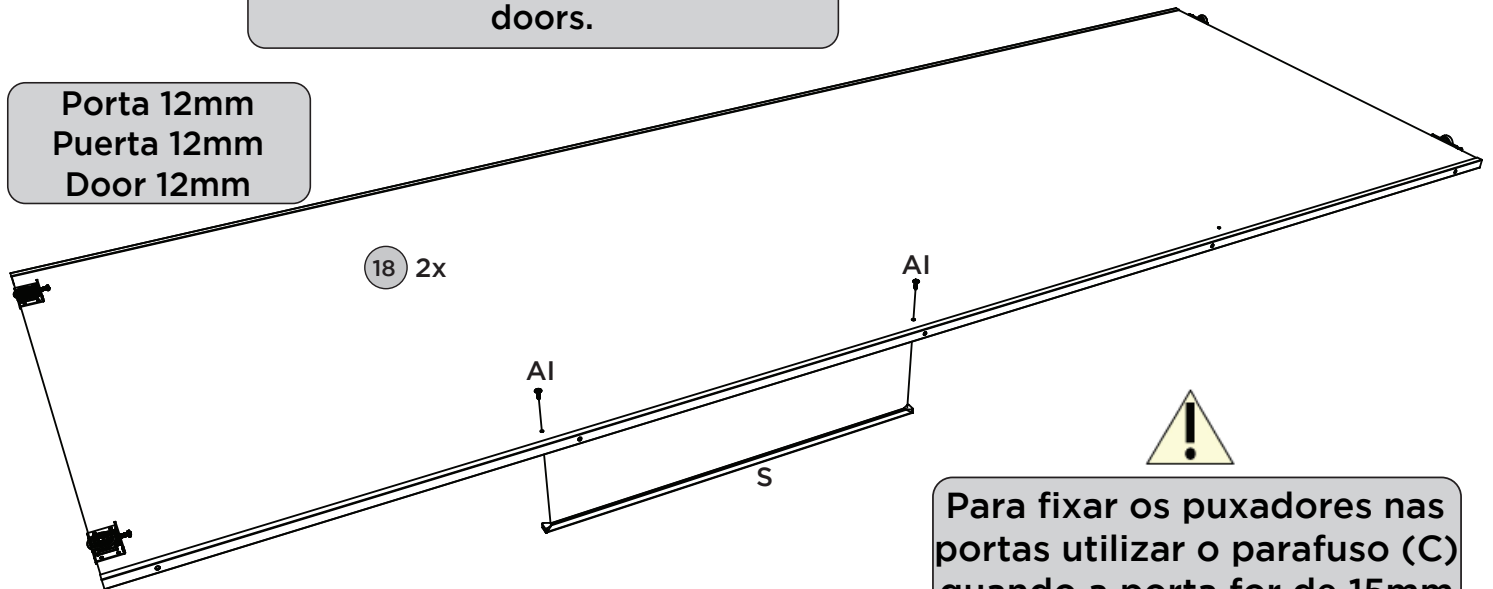

Para fixar os puxadores nas portas utilizar o parafuso (C) quando a porta for de 15mm e o parafuso (AI) quando a porta for de 12mm.

Para fijar las manijas en las puertas, utilice el tornillo (C) cuando la puerta sea de 15 mm y el tornillo (AI) cuando la puerta sea de 12 mm.

To fix the handles on the doors, use the screw (C) when the door is 15mm and the screw (AI) when the door is 12mm.

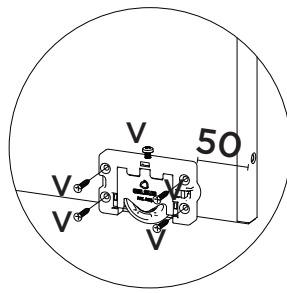
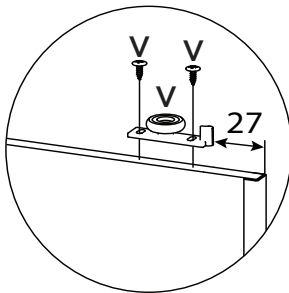

Porta 15mm
Puerta 15mm
Door 15mm

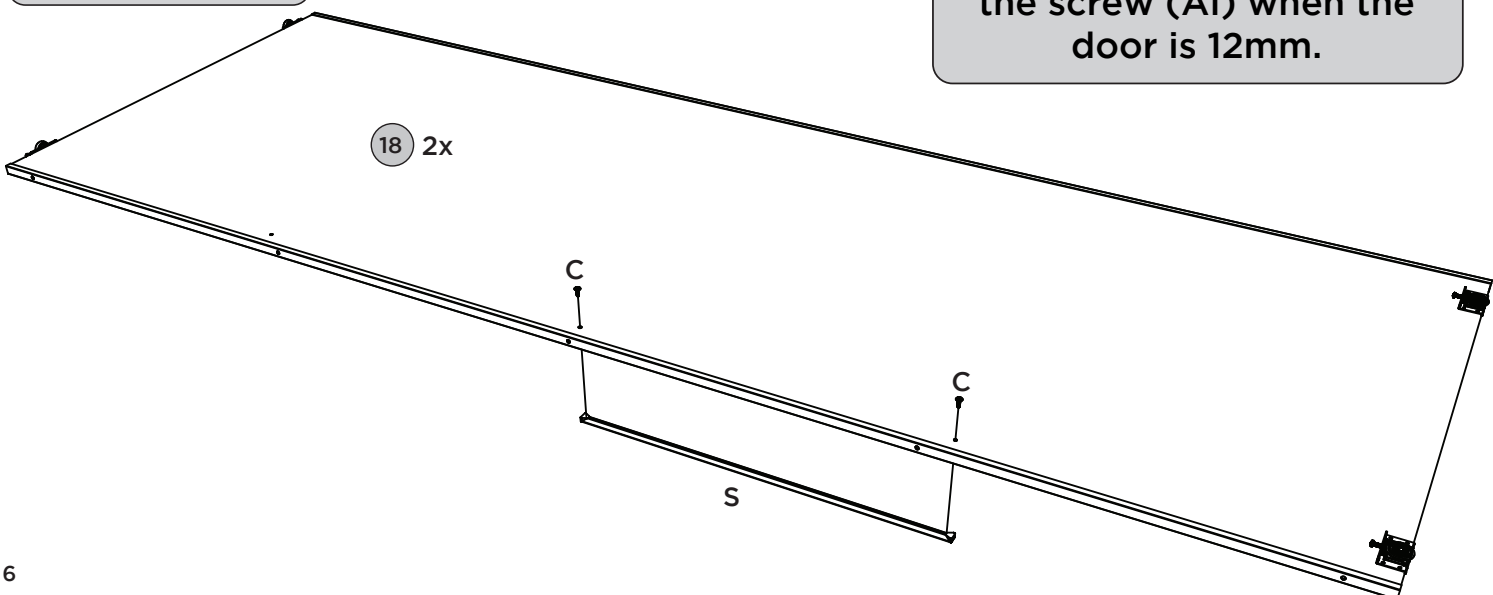

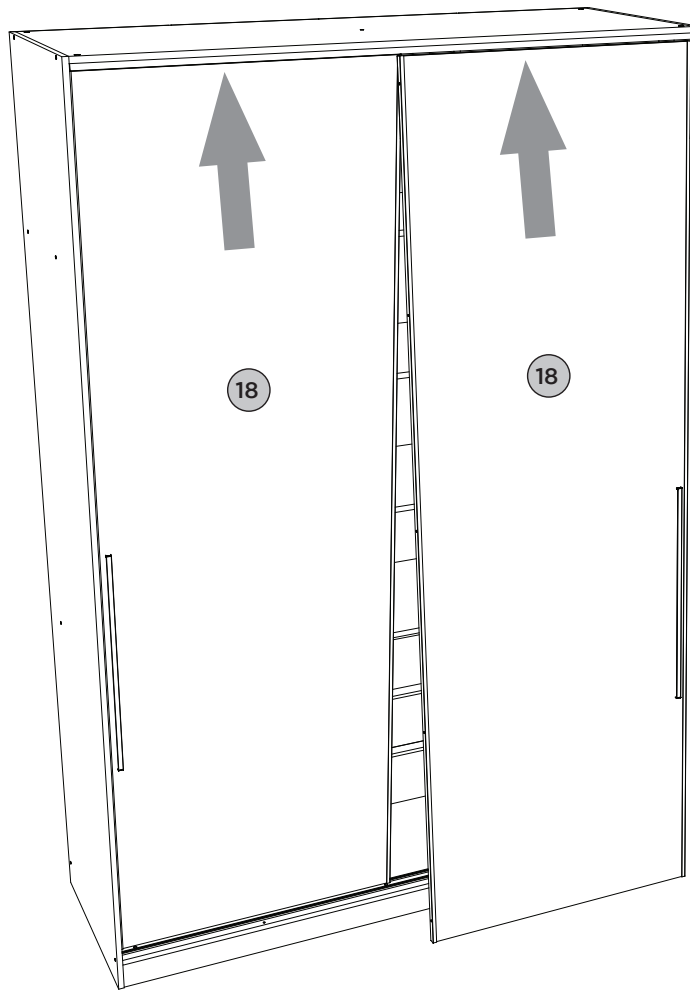

10 Montagem gaveta 3x. Montaje del cajón 3x. Mounting drawer 3x.

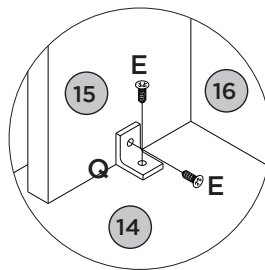
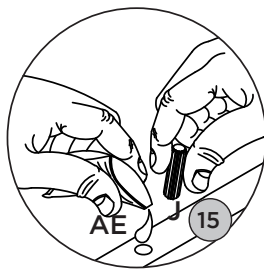
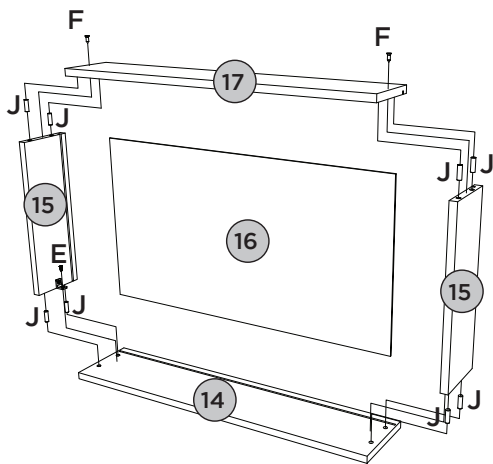

A corredeira (U) deverá ser alinhada com a parte de baixo do lado de gaveta (15)

La corredera (U) debe ser alineada con la parte de por el lado del cajón (15)

The slide (U) should be aligned with the underside of the drawer side (15)

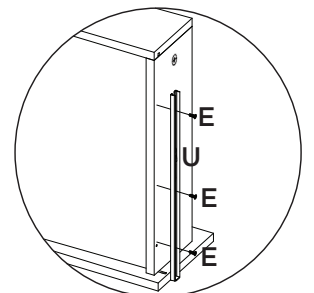
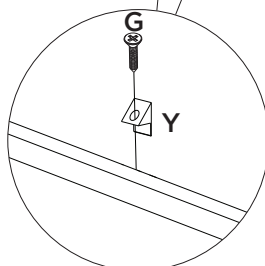
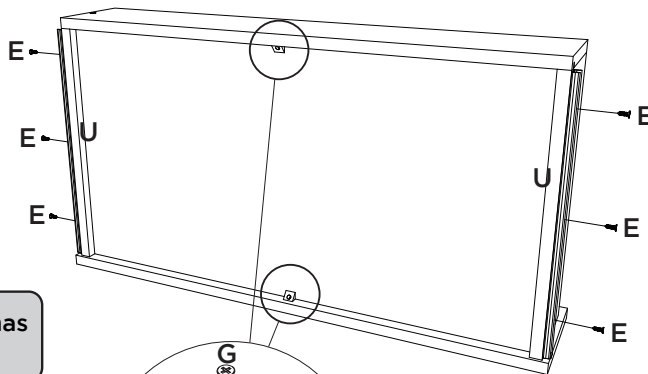
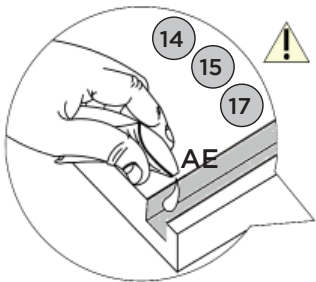













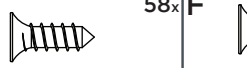

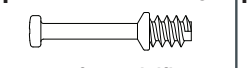



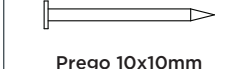





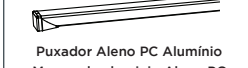
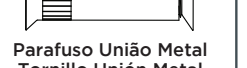

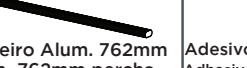



- Utilizar o Sachê de cola (AE) nas cavilhas (J) e nos frisos das gavetas.
- El uso de pegamento de paquetes (AE) sobre los pasadores (J) y las cuentas de los cajones.
- Use the glue sachet (AE) on the pegs (J) and on the frieze of the drawers.

Lista de Peças | Lista de piezas | List of parts

Item	Caixa Caja Box	Qty Ctd Qty	Descrição Descripción Description	Medidas (mm) Dimensions (mm) Size (measurements) (mm)
01	1/3	01	Rodapé Frontal Rodapié Frontal Front baseboard	1555x73x15
02	1/3	01	Travessa do rodapé Carril pie Baseboard crosspiece	455x73x15
03	1/3	01	Rodapé Traseiro Rodapié trasero Rear baseboard	1555x73x15
04	1/3	01	Base Base Base	1555x520x15
05	2/3	01	Lateral esquerda Lateral izquierda Left side	2400x520x15
06	2/3	01	Divisão División Division	2297x450x15
07	1/3	01	Prateleira do varão Estantería hombre Rod shelf	770x250x15
08=10	1/3	01	Prateleira Estante Shelf	770x420x15
09	2/3	01	Lateral direita Lateral derecha Right side	2400x520x15
10=08	1/3	04	Prateleira Estante Shelf	770x420x15
11	1/3	01	Tampo Tapa Top	1555x520x15
12	2/3	04	Fundo Fondo Bottom	2327x391x3
13	1/3	02	Ripa lateral Lado ripa Lateral clamp	530x80x25
14	1/3	03	Frente de gaveta Frente de cajón Front of drawer	712x152x15
15	1/3	06	Lado de gaveta Lado del cajón Side of drawer	350x122x15
16	2/3	03	Fundo de gaveta recortado Fondo del cajón recortado Cropped drawer bottom	676x361x3
17	1/3	03	Ripa de trás Malla detrás Rear lath	695x122x15
18	3/3	02	Porta Deslizante Puerta corrediza Sliding door - Areia HP	2267x783x12
18	3/3	02	Porta Deslizante Puerta corrediza Sliding door - Jequitibá	2267x783x15

Ferragens | Herrajes | Hardware

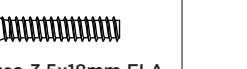
A  Parafuso 4,5x50mm CHT. Tornillo 4,5x50mm CHT. Screw 4,5x50mm CHT.	08x	B  Parafuso 3,5x40mm CHT. Tornillo 3,5x40mm CHT. Screw 3,5x40mm CHT.	18x	C  Parafuso 3,5x20mm FLA. Tornillo 3,5x20mm FLA. Screw 3,5x20mm FLA.	04x	D  Parafuso 3,5x14mm FLA. Tornillo 3,5x14mm FLA. Screw 3,5x14mm FLA.	10x	E  Parafuso 3,5x12mm CHT. Tornillo 3,5x12mm CHT. Screw 3,5x12mm CHT.	58x	F  Parafuso 3,0x30mm CHT. Tornillo 3,0x30mm CHT. Screw 3,0x30mm CHT.	06x
G  Parafuso 3,0x16mm CHT. Tornillo 3,0x16mm CHT. Screw 3,0x16mm CHT.	06x	H  Parafuso minifix Tornillo minifix Minifix bolt	02x	I  Parafuso 4,0x35mm CHT. Tornillo 4,0x35mm CHT. Screw 4,0x35mm CHT.	06x	J  Cavilha 8x25mm Cinta 8x25mm Dowel 8x25mm	68x	K  Tambor minifix Tambor minifix Minifix drum	02x	L  Porca cilíndrica Tuerca cilíndrica Cylindrical nut	08x
M  Prego 10x10mm Clavo 10x10mm Nail 10x10mm	128x	N  Prego 12x12mm Anelado Clavo 12x12mm Anillado Ringed Nails 12x12mm	06x	O  Sapata "L" 16x20mm Zapata "L" 16x20mm "L" shoe 16x20mm	06x	P  Fixador de fundos Fijador de fondos Bottom fixer	22x	Q  Cantoneira plástica Cantonera plástica Plastic angle brackets	08x	R  Suporte cabideiro Soporte de percha Coat hanger support	04x
S  Puxador Aleno PC Alumínio Mango de alumínio Aleno PC Aleno PC Aluminum Handle	02x	T  Parafuso União Metal Tornillo Unión Metal Metal Union Screw	05x	U  Corrediça telescópica Corredera telescópica Telescopic slide	03x	V  Kit Rodizio CM 110 Silence com Rolamento 2Pis Kit Ruedas CM 110 Silence con Cojinete 2Pis Caster Kit CM 110 Silence with Bearing 2Pis	01x	W  Cabideiro Alum. 762mm Alum. 762mm percha Alum. coat hanger 762mm	02x	X  Adesivo tapa parafuso 17mm Adhesivo tapón de tornillo 17mm Bolt cover adhesive 17mm	02x
Y  Cantoneira suporte triangular Cantonera soporte triangular Triangle support angle	06x	Z  Trilho Superior 1553mm Carril superior 1553mm Top Rail 1553mm	01x	AA  Trilho Inferior 1553mm Carril Inferior 1553mm Lower Rail 1553mm	01x	AB  Adesivo tapa parafuso 10mm Adhesivo tapón de tornillo 10mm Bolt cover adhesive 10mm	49x	AC  Perfil H 2312mm Perfil H 2312mm H profile 2312mm	02x	AD  Etiqueta resinada Henn Etiqueta resinada Henn Henn resin label	01x
AE  Sachê de cola Bolsa de pegamento Glue bag	02x	AF  Giz de correção Tiza de corrección Chalk of correction	02x	AG  Perfil Anti-empeno 2299mm Perfil anti-empeno 2299mm Anti-warp profile U 2299mm	04x	AH  Distanciador de corrediça Distanciador de deslizamiento Sliding spacer	06x	AI  Parafuso 3,5x18mm FLA. Tornillo 3,5x18mm FLA. Screw 3,5x18mm FLA.	04x		

A ferragem "AG" só será usada em caso de pedido de assistência técnica, pois o perfil antiempeno "U" já vem montado nas portas de fábrica.

El hardware "AG" sólo se utilizará en caso de solicitud de asistencia técnica, ya que el perfil antiempeno "U" ya viene montado en las puertas de fábrica.

The "AG" hardware will only be used in the event of a service request, as the "U" anti-pilling profile is already installed on the factory doors.

A união (T) deve ser usada somente quando este módulo for acoplado a outro módulo componível Henn, para unir duas peças de 15mm. Caso ele seja usado separadamente, a utilização do união não se faz necessário.

La unión (T) se debe utilizar sólo cuando el módulo está acoplado a otro módulo componible Henn, para unirse a dos 15mm piezas. Si se utiliza por separado, el uso de unión no es necesario.

The union (T) should be used only when this module is coupled to another Module Henn, to join two pieces of 15mm. If it is used separately, the use of the union is not necessary.

Canto Oblíquo 1 Porta Seletto | Esquina oblicua 1 Porta Seletto | Oblique Corner 1 Door Seletto

MC07-133 Areia HP

MC07-184 Areia HP/Jequitibá

Opção 1
Opción 1
Option 1

Opção 2
Opción 2
Option 2

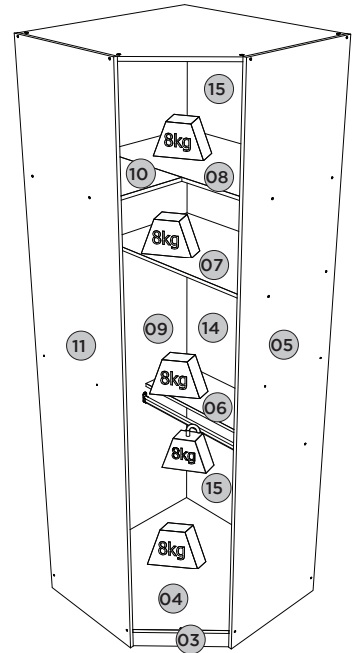
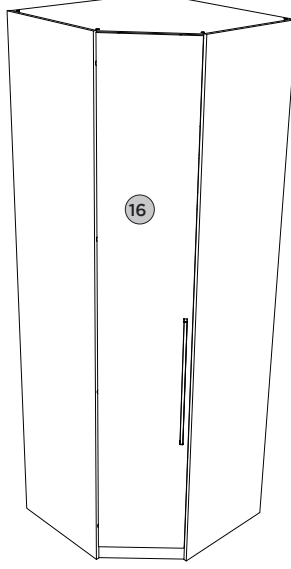
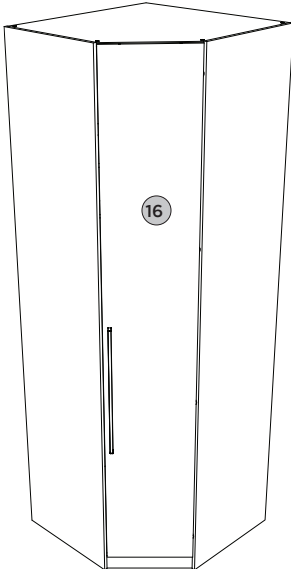

Requisitos para montagem Requisitor para la montaje Assembly Requirements

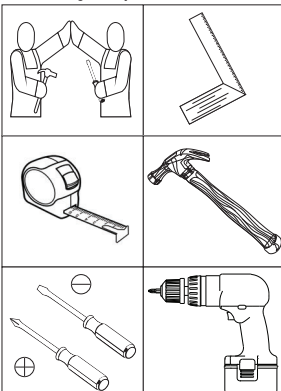

Imagens meramente ilustrativas
Imágenes meramente ilustrativas
Images for illustration only

Pesos máximos recomendados com carga distribuída
Peso máximo recomendado con la carga distribuida
Recommended maximum weights with evenly distributed.

AVISO

Para limpeza de seu móvel, use uma flanela seca ou umedecida, e não utilize produtos químicos que possam danificar seu produto.

SISTEMA DE MONTAGEM

O sistema de montagem dos produtos, funciona de acordo com a ordem crescente dos números indicados no desenho. Ex: 01, 02, 03, 04... até a conclusão da montagem.

ADVERTENCIA

Para limpieza de su móvel, use una franela seca o húmeda, y no utilice productos químicos que puedan dañar su producto.

SISTEMA DE MONTAJE

El sistema de montaje de los productos funciona de acuerdo con el orden creciente de los números indicados en el dibujo. Ej.: 01, 02, 03, 04... hasta la conclusión del montaje.

NOTICE

To clean your furniture, use a dry or wet cloth, and do not use chemicals that may damage your product.

ASSEMBLY SYSTEM

The products' assembly system works according to the increasing order of the indicated numbers. For example: 01, 02, 03, 04 ... to the end of the assembly.

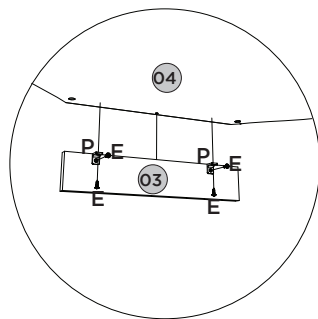
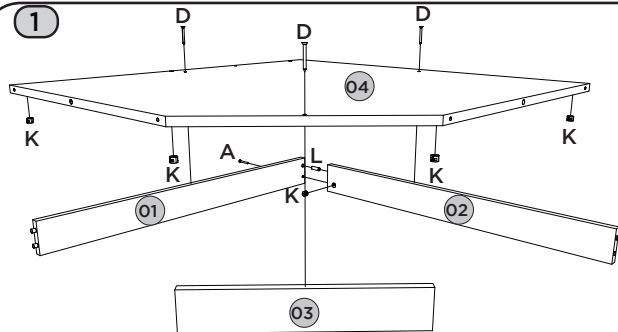

ATENÇÃO: Quando o Canto Obliquo for acoplado à Mesa de Cabeceira, a porta do Canto deverá abrir no sentido do Mesa de Cabeceira.

ATENCIÓN: Cuando la Esquina Inclinada se une a la Mesita de Noche, la puerta de la Esquina debe abrirse hacia la Mesita de Noche.

ATTENTION: When the Slanted Corner is attached to the Bedside Table, the Corner door must open towards the Bedside Table.

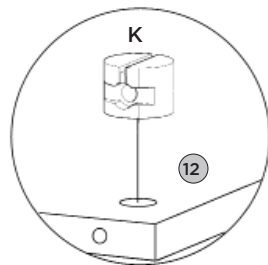
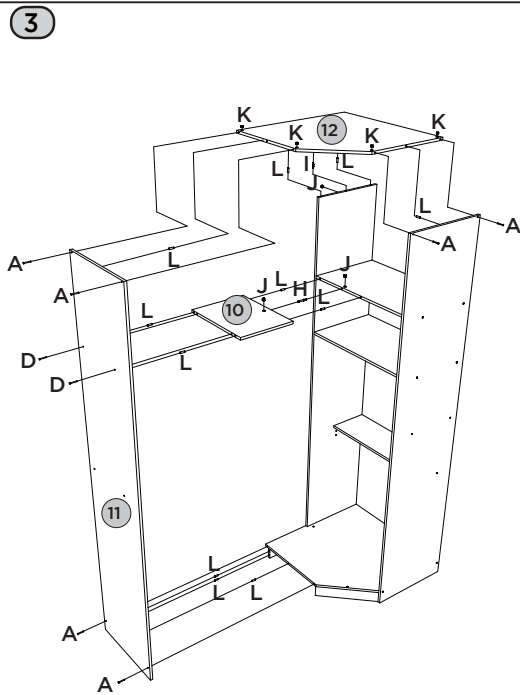
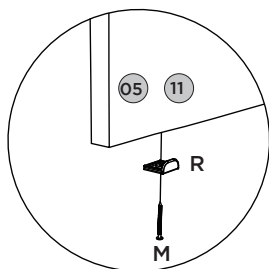
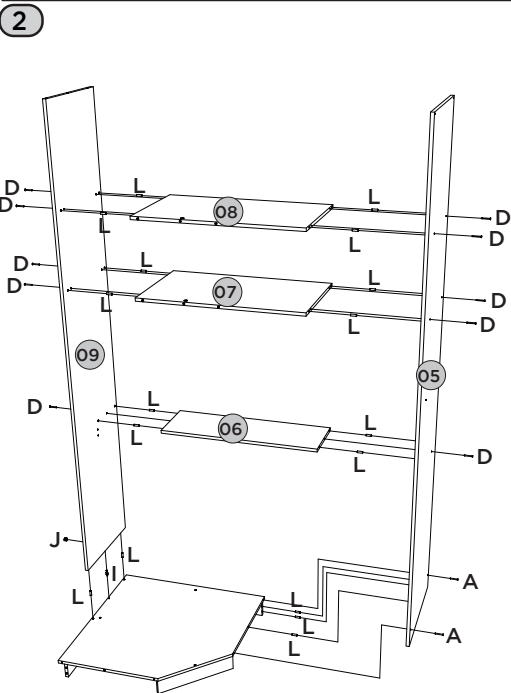
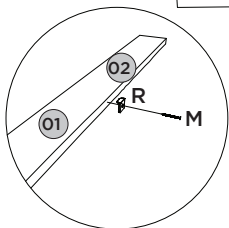

4

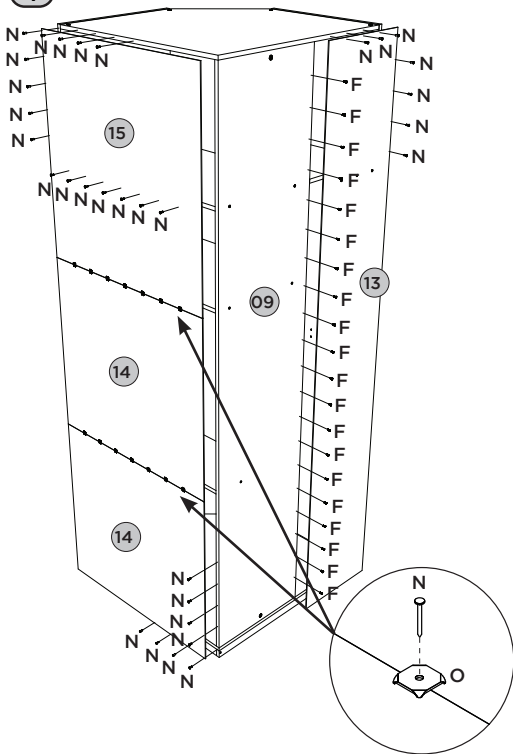

5

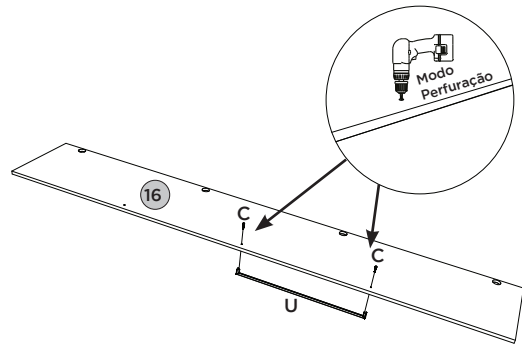

Fazer furação passante para fixar os puxadores, utilizando as pré marcações existentes nas portas.

Taladre agujeros para fijar las manijas, utilizando las marcas previas en las puertas.

Drill through holes to fix the handles, using the pre-markings on the doors.

6

Fazer furação passante para fixar o puxador, utilizando as pré marcações existentes nas portas.





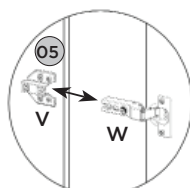
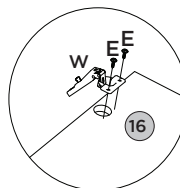
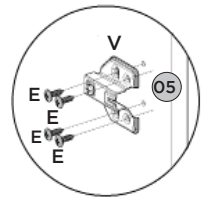
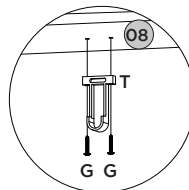
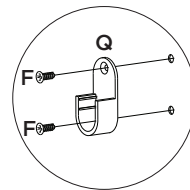
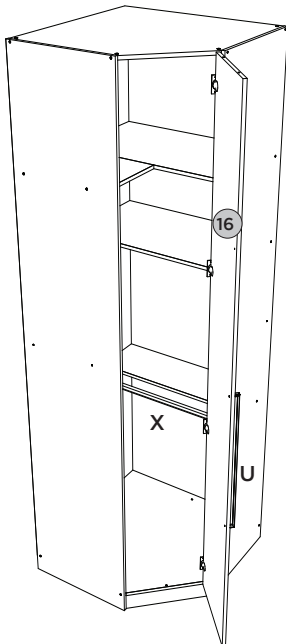









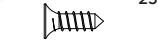

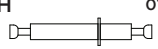
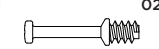

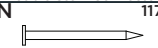

Taladre agujeros para fijar la manija, utilizando las marcas previas en las puertas.

Drill through holes to fix the handle, using the pre-markings on the doors.

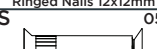

Item	Caixa Caja Box	Qtd Ctd Qty	Descrição Descripción Description	Medidas (mm) Dimensions (mm) Size (measurements) (mm)
01	1/3	01	Rodapé Traseiro Maior Rodapié trasero mayor Larger Back Footer	764x73x15
02	1/3	01	Rodapé Traseiro Menor Rodapié trasero menor Rear Footer Minor	749x73x15
03	1/3	01	Rodapé Frontal Rodapié Frontal Front baseboard	395x73x15
04	1/3	01	Base Base Base	796x796x15
05	2/3	01	Lateral direita Lateral derecha Right side	2400x520x15
06	1/3	01	Prateleira do varão Estantería hombre Rod shelf	781x520x15
07	1/3	01	Prateleira Estante Shelf	781x450x15
08	1/3	01	Prateleira fixa Estante fija Fixed shelf	781x450x15
09	2/3	01	Fundo 15mm Fondo 15mm 15mm Bottom	2296x450x15
10	1/3	01	Prateleira Menor Estante menor Minor shelf	346x450x15
11	2/3	01	Lateral esquerda Lateral izquierda Left side	2400x520x15
12	1/3	01	Tampo Tapa Top	796x796x15
13	2/3	01	Fundo Fondo Bottom	2324x370x3
14	1/3	02	Fundo Inferior Fondo inferior bottom background	730x805x3
15	1/3	01	Fundo Superior Fondo superior Superior background	854x805x15
16	3/3	01	Porta Puerta Door	2320x391x15

Ferragens | Herrajes | Hardware

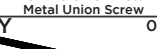
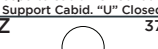
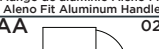
A  Parafuso 4,5x50mm CHT. Tornillo 4,5x50mm CHT. Screw 4,5x50mm CHT.	B  Etiqueta resinada Henn Etiqueta resinada Henn Henn resin label	C  Parafuso 3,5x22mm CHT. Tornillo 3,5x22mm CHT. Screw 3,5x22mm CHT.	D  Parafuso 3,5x40mm CHT. Tornillo 3,5x40mm CHT. Screw 3,5x40mm CHT.	E  Parafuso 3,5x14mm FLA. Tornillo 3,5x14mm FLA. Screw 3,5x14mm FLA.	F  Parafuso 3,5x12mm CHT. Tornillo 3,5x12mm CHT. Screw 3,5x12mm CHT.
G  Parafuso 3,0x20mm FLA. Tornillo 3,0x20mm FLA. Screw 3,0x20mm FLA.	H  Conector de Haste Dupla Conector de vástago doble Double Stem Connector	I  Parafuso minifix Tornillo minifix Minifix bolt	J  Tambor minifix Tambor minifix Minifix drum	K  Porca cilíndrica Tuerca cilíndrica Cylindrical nut	L  Cavilha 8x25mm Cinta 8x25mm Dowel 8x25mm
M  Prego 12x12mm Anelado Clavo 12x12mm Anilado Ringed Nails 12x12mm	N  Prego 10x10mm Clavo 10x10mm Nail 10x10mm	O  Fixador de fundos Fijador de fondos Bottom fixer	P  Cantoneira plástica Cantoneira plástica Plastic angle brackets	Q  Suporte cabideiro Soporte de percha Coat hanger support	R  Sapata "L" 16x20mm Zapata "L" 16x20mm "L" shoe 16x20mm
S  Parafuso União Metal Tornillo Unión Metal Metal Union Screw	T  Suporte Cabid. "U" Fechado Soporte Cabid. "U" Cerrado Supporte Cabid. "U" Closed	U  Puxador Aleno Fit Alumínio Mango de aluminio Aleno Fit Aleno Fit Aluminum Handle	V  Calço Removível p Dob 45° Calzado extraíble p Dob 45° Removable chock p Dob 45°	W  Dobradica 45° Caneca 35mm com Amortecimento Bisagra 45° Taza 35mm con Amortiguación Hinge 45° Mug 35mm with Damping	X  Cabideiro Alum. 384mm Alum. 384mm percha Alum. coat hanger 384mm
Y  Cabideiro Alum. 773mm Alum. 773mm percha Alum. coat hanger 773mm	Z  Adesivo tapa parafuso 10mm Adhesivo tapón de tornillo 10mm Bolt cover adhesive 10mm	AA  Giz de correção Tiza de corrección Chalk of correction			

A união (S) deve ser usada somente quando este módulo for acoplado a outro módulo componível Henn, para unir duas peças de 15mm. Caso ele seja usado separadamente, a utilização do união não se faz necessário.

La unión (S) se debe utilizar sólo cuando el módulo está acoplado a otro módulo composable Henn, para unirse a dos 15mm piezas. Si se utiliza por separado, el uso de unión no es necesario.

The union (S) should be used only when this module is coupled to another Module Henn, to join two pieces of 15mm. If it is used separately, the use of the union is not necessary.



Roupeiro 02 Portas Cabideiros Seletto
Armario 02 Puertas Bastidores Seletto
Wardrobe 02 Doors Coat Racks Seletto

Referência/Cor

- c MC08-133 Areia HP
- c MC08-184 Areia HP/Jequitibá
- c MC09-133 Areia HP
- c MC09-184 Areia HP/Jequitibá

Opção 1
Opción 1
Option 1

Opção 2
Opción 2
Option 2

Requisitos para montagem
Requisitor para la montaje
Assembly Requirements

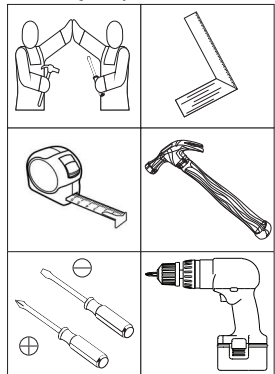

Imagens meramente ilustrativas
Imágenes meramente ilustrativas
Images for illustration only

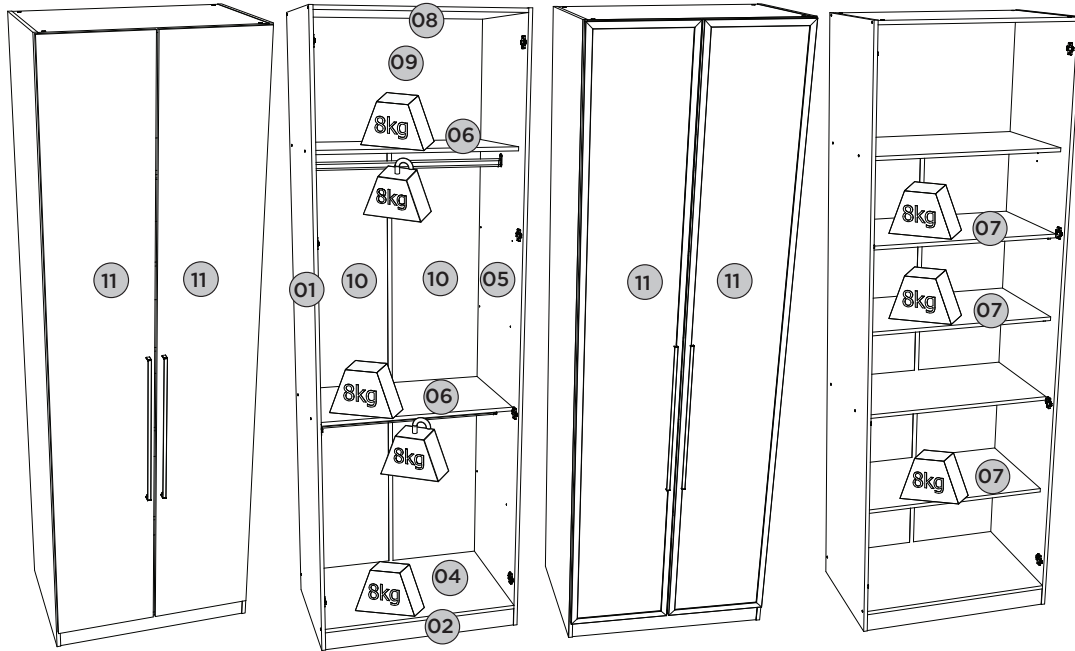

Lista de Peças | Lista de piezas | List of parts

Item	Caixa Caja Box	Qtd Ctd Qty	Descrição Descripción Description	Medidas (mm) Dimensiones (mm) Size (measure- ments) (mm)
01	2/3	01	Lateral esquerda Lateral izquierda Left side	2400x520x15
02	1/3	01	Rodapé frontal Pie delantero Front baseboard	770x73x15
03	1/3	01	Rodapé traseiro Pie trasero Rear baseboard	770x73x15
04=08	1/3	01	Base Tampo Base Tapa Base and Top	770x520x15
05	2/3	01	Lateral direita Lateral derecha Right side	2400x520x15
06	1/3	02	Prateleira estante shelf	770x450x15
07	1/3	03	Prateleira móvel Estante móvil Mobile shelf	770x450x15
08=04	1/3	01	Base Tampo Base Tapa Base and Top	770x520x15
09	2/3	01	Fundo superior arriba abajo top bottom	790x489x3
10	2/3	02	Fundo Fondo Bottom	1829x393x3
11	3/3	02	Porta Puerta Door	2320x391x15
11	3/3	02	Porta Espelho Puerta de espejo Mirror Door	2320x391x20

Pesos máximos recomendados com carga uniformemente distribuídas.
Peso máximo recomendado con la carga distribuida uniformemente.
Recommended maximum weights with evenly distributed.

AVISO

Para limpeza de seu móvel, use uma flanela seca ou umedeçada, e não utilize produtos químicos que possam danificar seu produto.

SISTEMA DE MONTAGEM

O sistema de montagem dos produtos, funciona de acordo com a ordem crescente dos números indicados no desenho. Ex: 01, 02, 03, 04... até a conclusão da montagem.

ADVERTENCIA

Para limpieza de su móvil, use una flanela seca o húmeda, y no utilice productos químicos que puedan dañar su producto.

SISTEMA DE MONTAJE

El sistema de montaje de los productos funciona de acuerdo con el orden creciente de los números indicados en el dibujo. Ej.: 01, 02, 03, 04... hasta la conclusión del montaje.

NOTICE

To clean your furniture, use a dry or wet cloth, and do not use chemicals that may damage your product.

ASSEMBLY SYSTEM

The products' assembly system works according to the increasing order of the indicated numbers. For example: 01, 02, 03, 04 ... to the end of the assembly.

A união (B) deve ser usada somente quando este módulo for acoplado a outro módulo componível Henn, para unir duas peças de 15mm. Caso ele seja usado separadamente, a utilização do união não se faz necessário.



La unión (B) se debe utilizar sólo cuando el módulo está acoplado a otro módulo componible Henn, para unirse a dos 15mm piezas. Si se utiliza por separado, el uso de unión no es necesario.



The union (B) should be used only when this module is coupled to another Module Henn, to join two pieces of 15mm. If it is used separately, the use of the union is not necessary.



Ferragens | Herrajes | Hardware

A Parafuso 4,5x50mm CHT. Tornillo 4,5x50mm CHT. Screw 4,5x50mm CHT.	B Parafuso União Metal Tornillo Unión Metal Metal Union Screw	C Parafuso 3,5x40mm CHT. Tornillo 3,5x40mm CHT. Screw 3,5x40mm CHT.	D Parafuso 3,5x22mm CHT. Tornillo 3,5x22mm CHT. Screw 3,5x22mm CHT.	E Parafuso 3,5x14mm FLA. Tornillo 3,5x14mm FLA. Screw 3,5x14mm FLA.	F Parafuso 3,5x12mm CHT. Tornillo 3,5x12mm CHT. Screw 3,5x12mm CHT.	G Cavilha 8x25mm Cinta 8x25mm Dowel 8x25mm	H Sapata "L" 16x20mm Zapata "L" 16x20mm "L" shoe 16x20mm
I Fixador de fundos Fijador de fondos Bottom fixer	J Prego 12x12mm Anelado Clavo 12x12mm Anillado Ringed Nails 12x12mm	K Prego 10x10mm Clavo 10x10mm Nail 10x10mm	L Porca cilíndrica Tuercas cilíndricas Cylindrical nut	M Puxador Aleno Fit Alumínio Mango de alumínio Aleno Fit Aleno Fit Aluminum Handle	N Suporte cabideiro Soporte de percha Coat hanger support	O Cabideiro Alum. 762mm Alum. 762mm percha Alum. coat hanger 762mm	P Calço Removível Calzado extraíble Removable Shim
Q Dobradilha SlideOn Alta Amort. 35mm Bisagra SlideOn Alta Amort. 35mm Hinge SlideOn High damper 35mm	R Adesivo tampa parafuso 10mm Adhesivo tapón de tornillo 10mm Bolt cover adhesive 10mm	S Etiqueta resinada Henn Etiqueta resinada Henn Henn resin label	T Suporte Prateleira 15x9 Soporte Estantería 15x9 Shelf Support 15x9	U Parafuso 3,5x25mm FLA. Tornillo 3,5x25mm FLA. Screw 3,5x25mm FLA.	V Perfil "H" 1812mm Perfil "H" 1812mm Profile "H" 1812mm	W Parafuso 3,0x16mm CHT. Tornillo 3,0x16mm CHT. Screw 3,0x16mm CHT.	

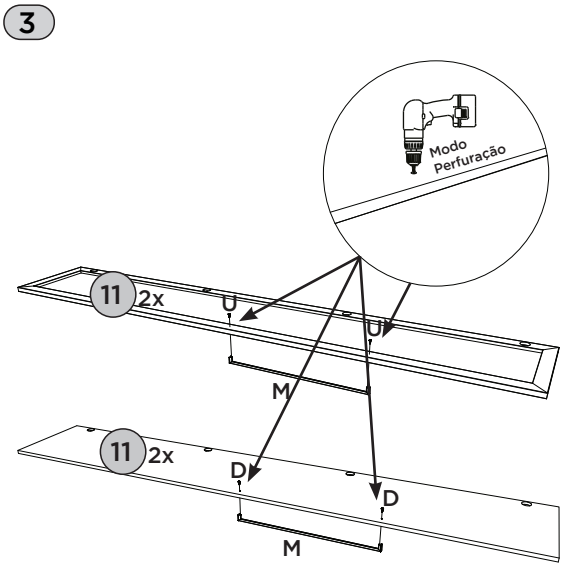
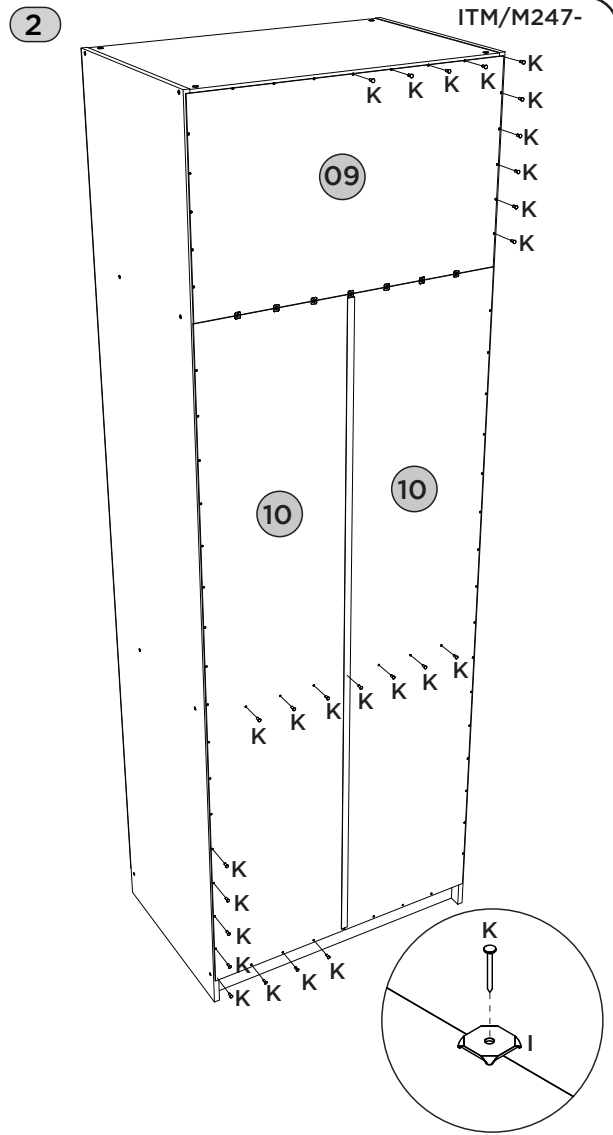
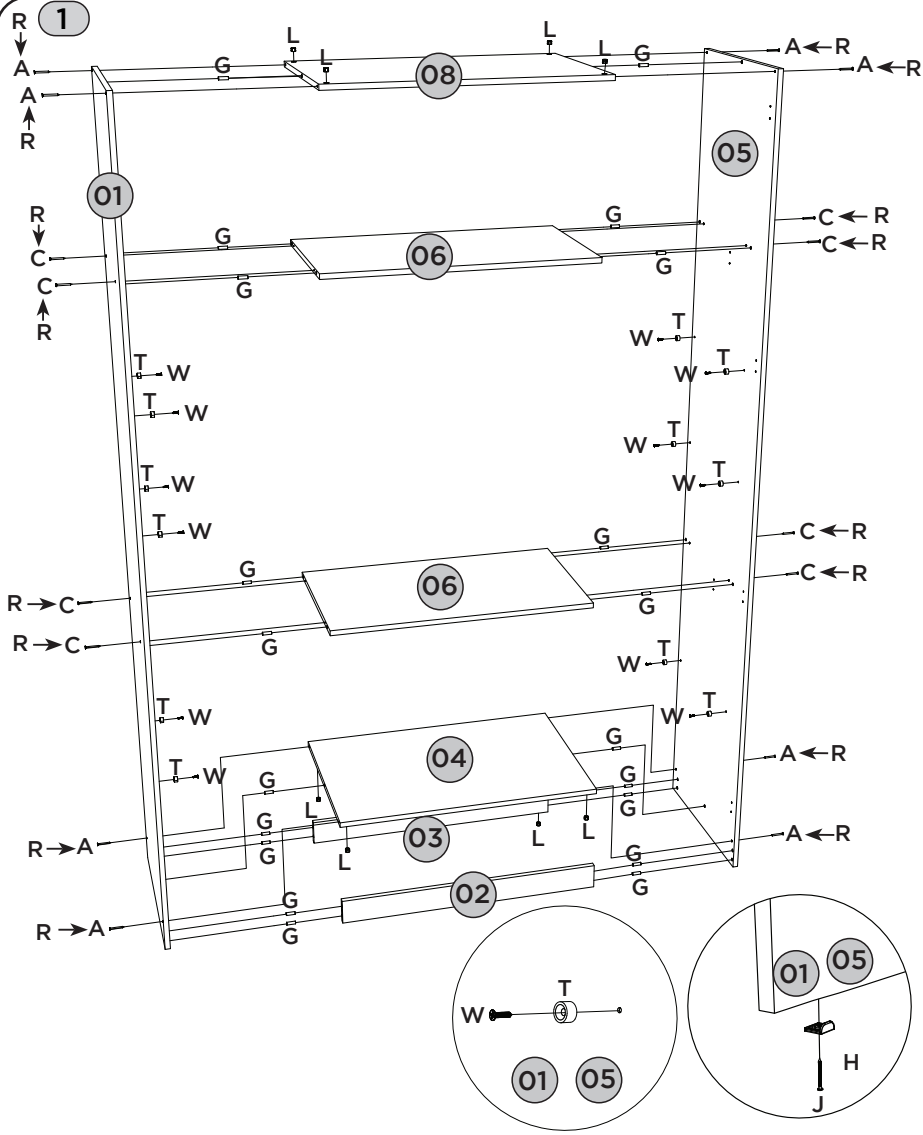

Fazer furação passante para fixar os puxadores, utilizando as pré marcações existentes nas portas.

Taladre agujeros para fijar las manijas, utilizando las marcas pre-vias en las puertas.

Drill through holes to fix the handles, using the pre-markings on the doors.

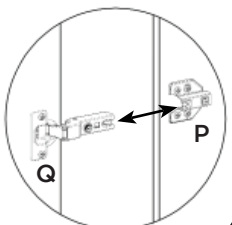
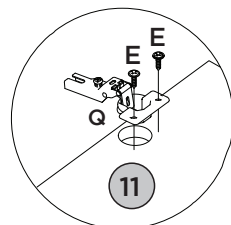
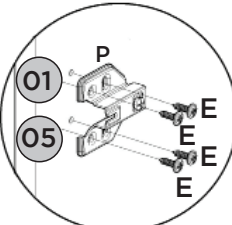
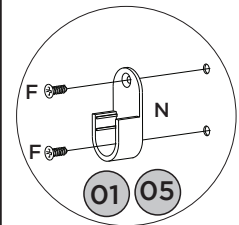
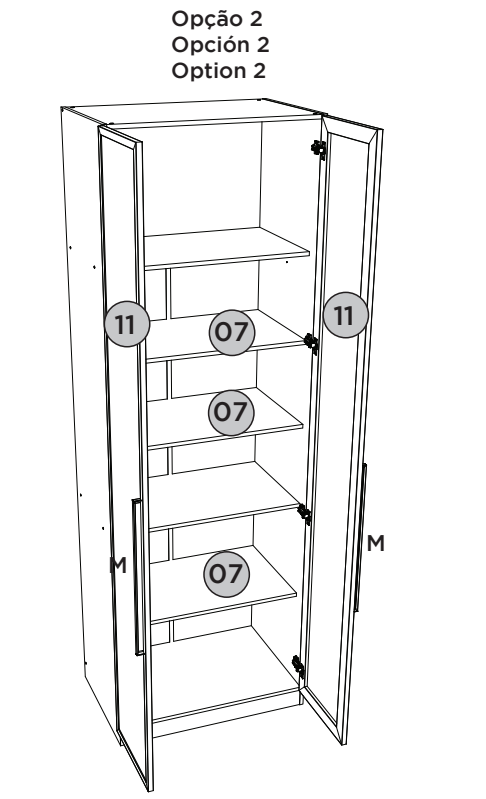
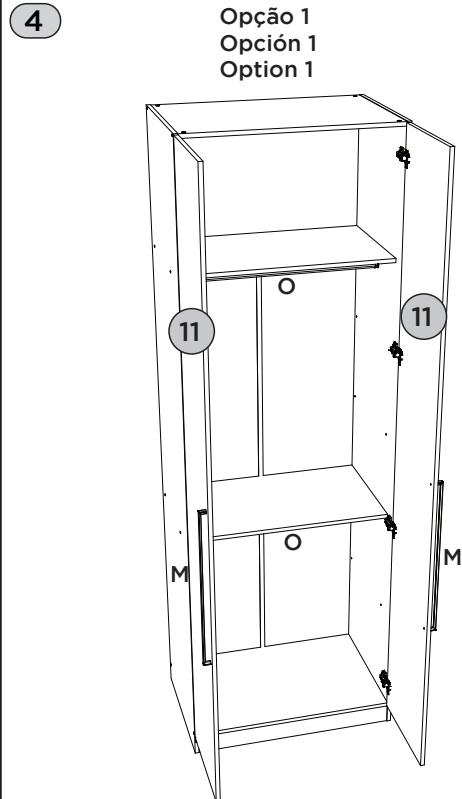

HENN

Ind. e Com. de Móveis Henn
Mondai - SC - Brasil

+55 49 3674.3500

@moveishenn
www.henn.com.br

INSTRUÇÕES DE MONTAGEM

INSTRUCCIONES DE MONTAJE
ASSEMBLY INSTRUCTIONS

Mesa de Cabeceira 1 Porta 03 Gavetas Seletto | Mesita de Noche 1 Puerta 03 Cajones Seletto |
Bedside Table 1 Door 03 Seletto Drawers

c MC02-133 Areia HP

c MC02-184 Areia HP/Jequitibá

Opção 1
Opción 1
Option 1

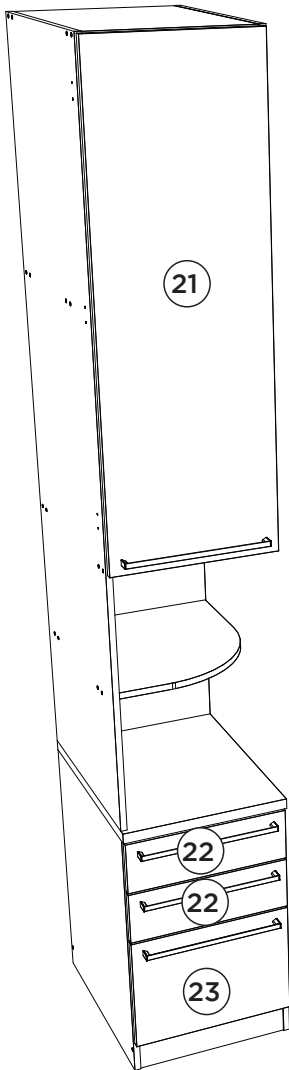

Opção 2
Opción 2
Option 2

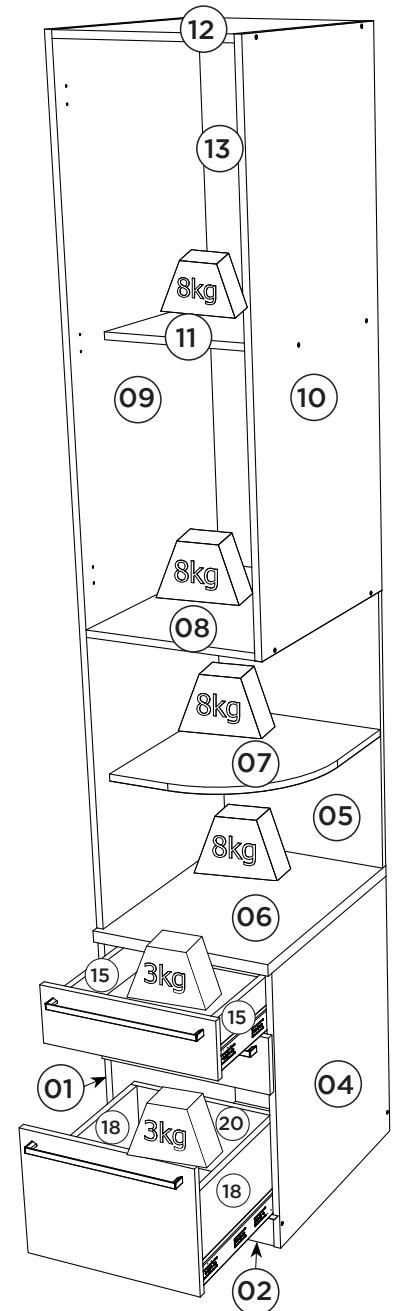
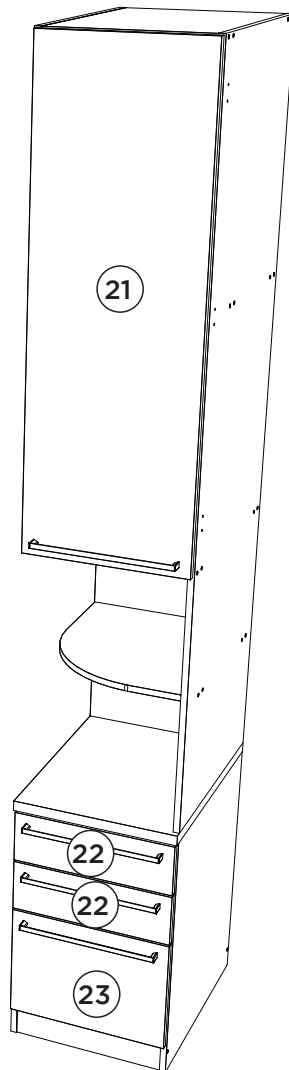

Requisitos para montagem
Requisitor para la montaje
Assembly Requirements

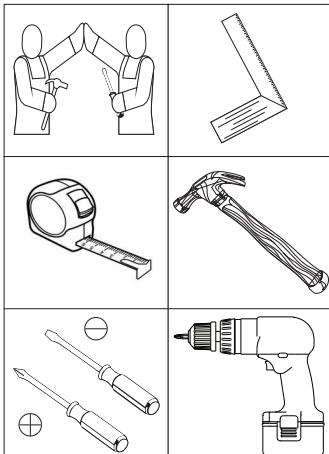

Imagens meramente ilustrativas
Imágenes meramente ilustrativas
Images for illustration only

Pesos máximos recomendados com carga distribuída
Peso máximo recomendado con la carga distribuida
Recommended maximum weights with evenly distributed.

AVISO

Para limpeza de seu móvel, use uma flanela seca ou umedecida, e não utilize produtos químicos que possam danificar seu produto.

SISTEMA DE MONTAGEM

O sistema de montagem dos produtos, funciona de acordo com a ordem crescente dos números indicados no desenho. Ex.: 01, 02, 03, 04... até a conclusão da montagem.

ADVERTENCIA

Para limpieza de su móvil, use una flanela seca o húmeda, y no utilice productos químicos que puedan dañar su producto.

SISTEMA DE MONTAJE

El sistema de montaje de los productos funciona de acuerdo con el orden creciente de los números indicados en el dibujo. Ej.: 01, 02, 03, 04... hasta la conclusión del montaje.

NOTICE

To clean your furniture, use a dry or wet cloth, and do not use chemicals that may damage your product.

ASSEMBLY SYSTEM

The products' assembly system works according to the increasing order of the indicated numbers. For example: 01, 02, 03, 04 ... to the end of the assembly.

1

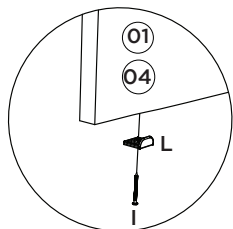
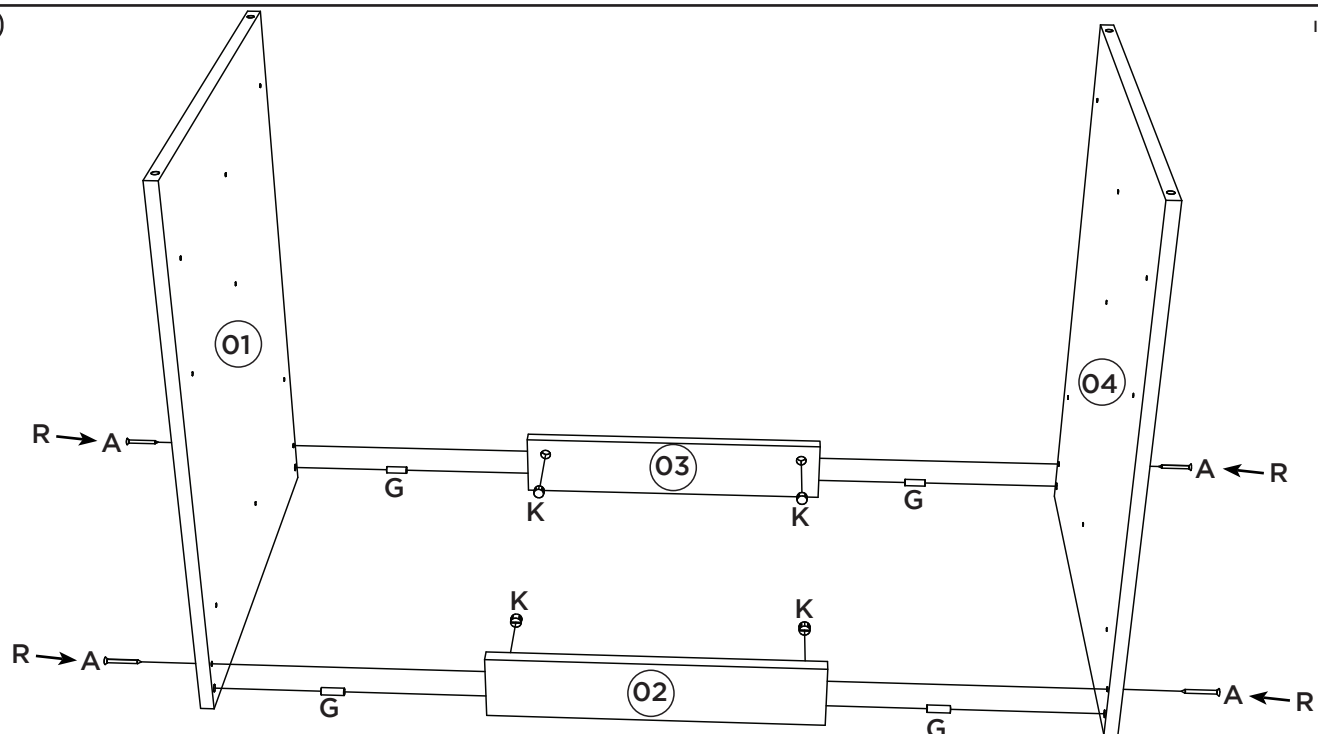

2

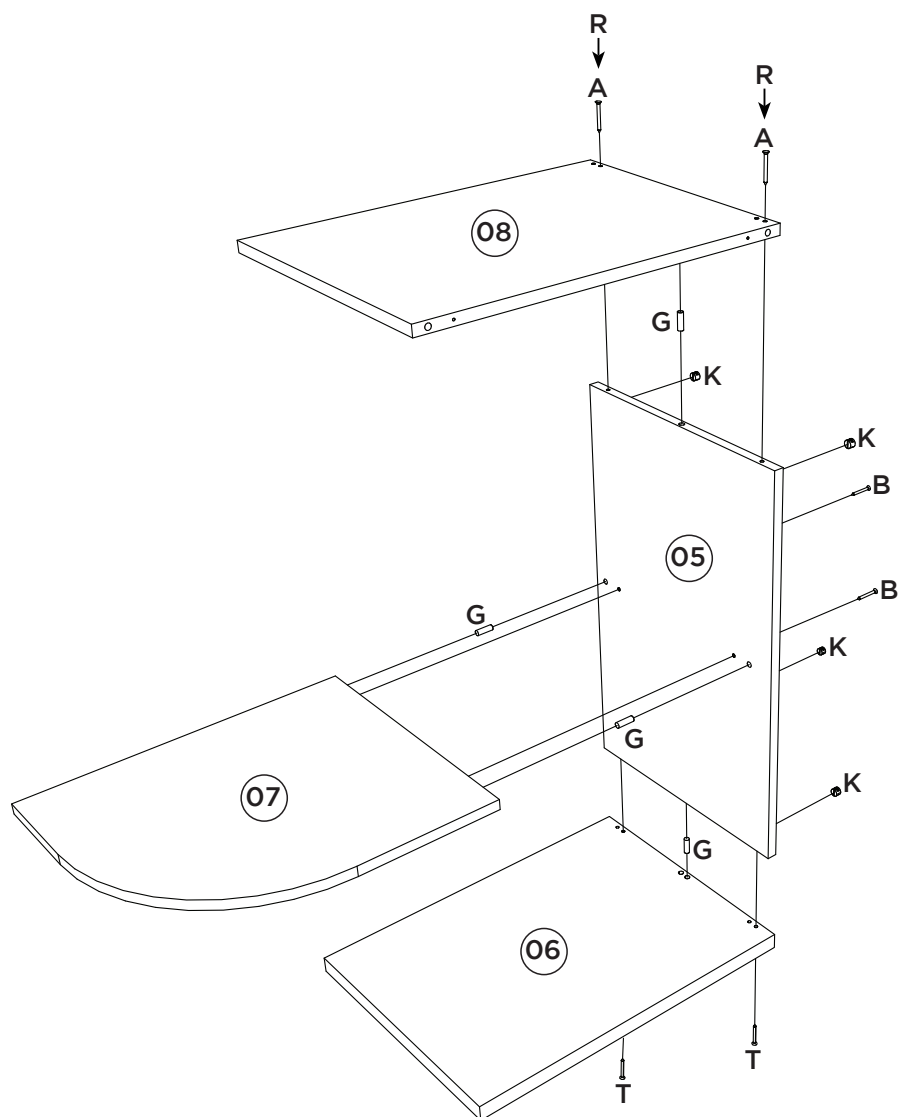

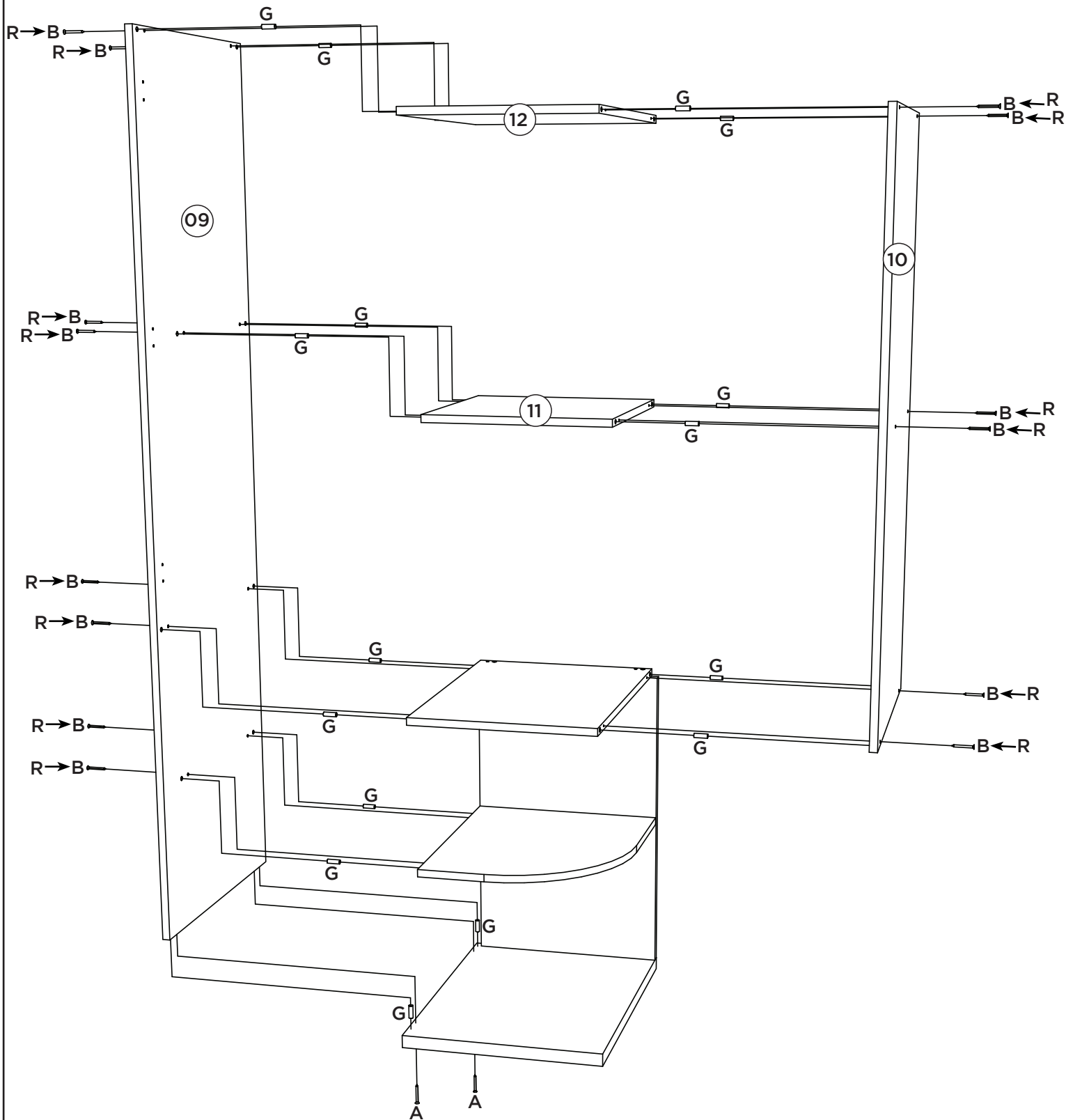

Fazer a furação passante para colocação da cavilha

Hacer la perforación pasante para colocar la clavija

Making the through hole for the pin placement

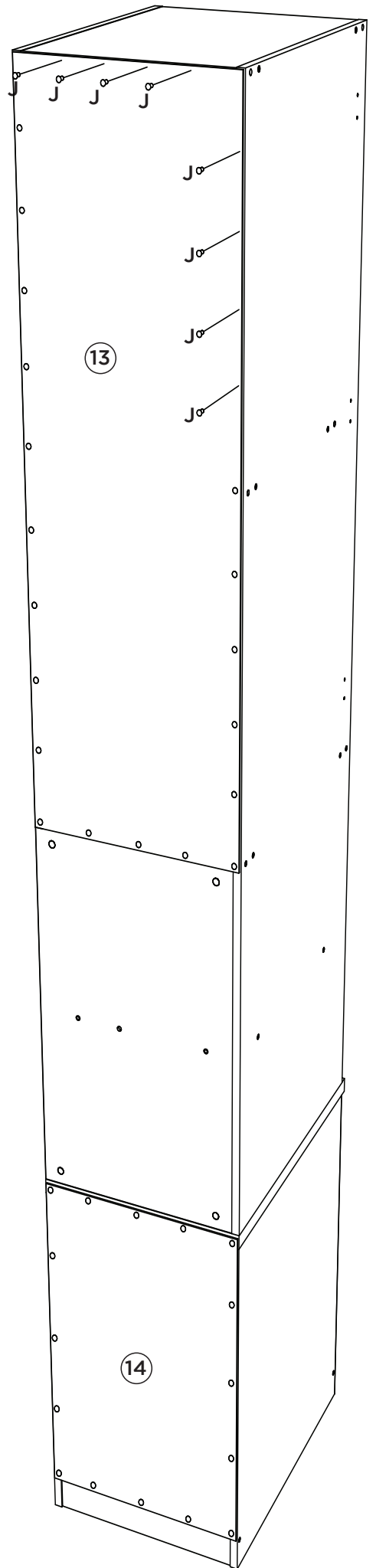
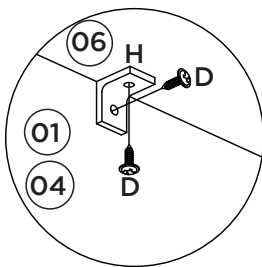
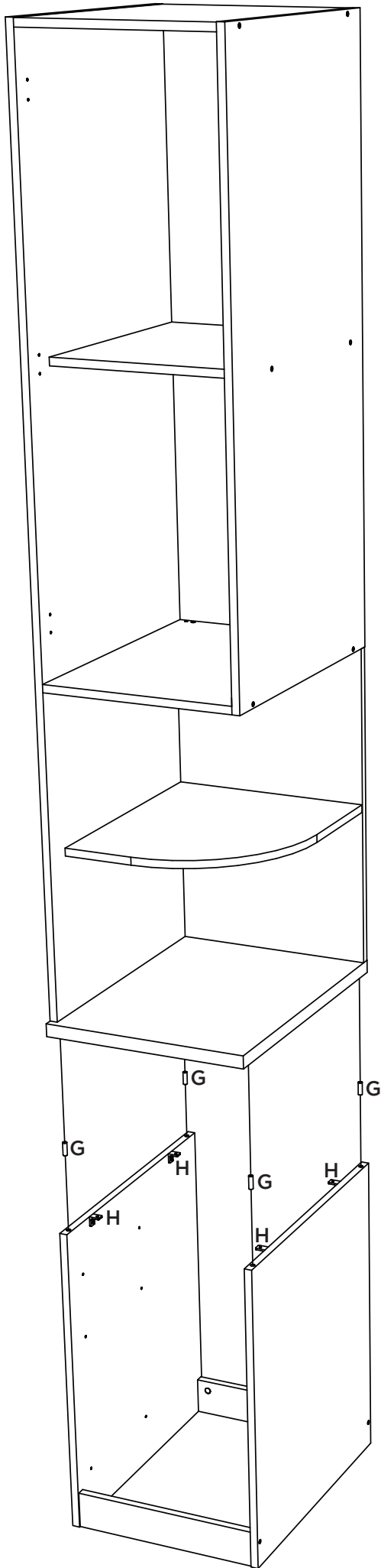

14

13

J

J

J

J

14

6

Observação: As ferragens que serão utilizadas na porta e gavetas, já acompanham o produto.

Nota: Los herrajes que se utilizarán en la puerta y los cajones ya están incluidos con el producto.

Note: The hardware that will be used in the door and drawers are already included with the product.

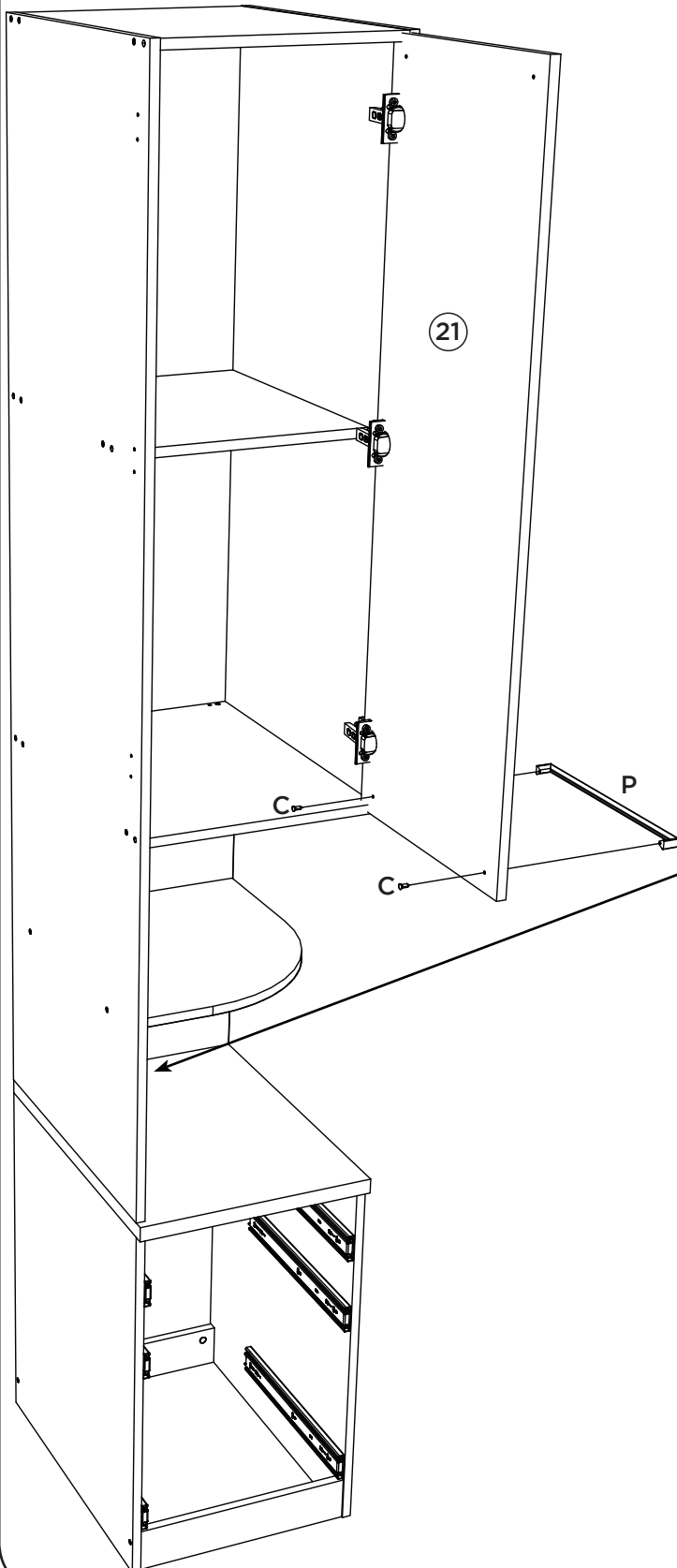
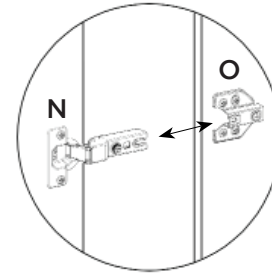
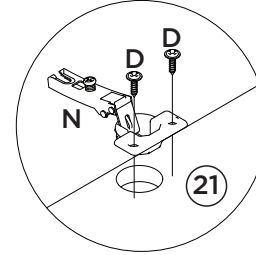
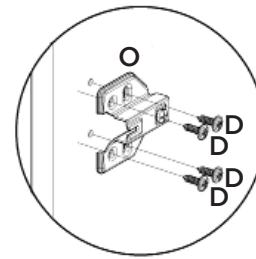

OPCIONAL: Kit Tomada Preta (01010194)
 OPTIONAL: Kit socket Black (01010194)
 OPTIONAL: Black Outlet Kit (01010194)

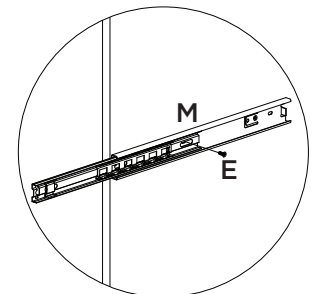
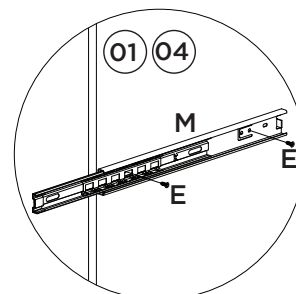
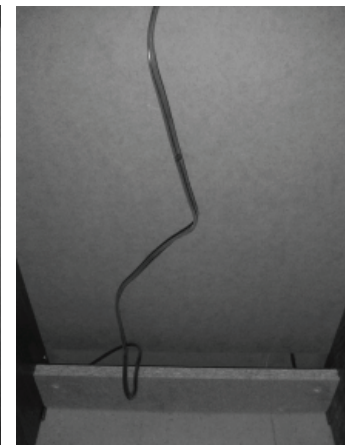
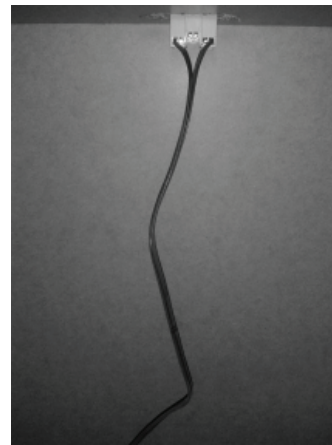

2X

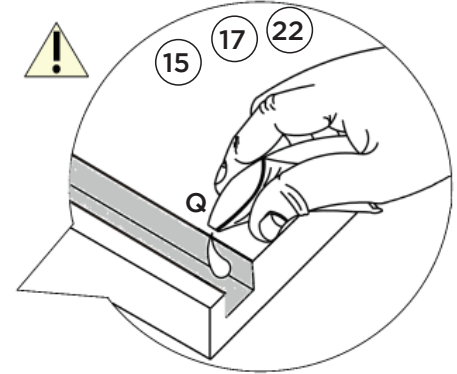
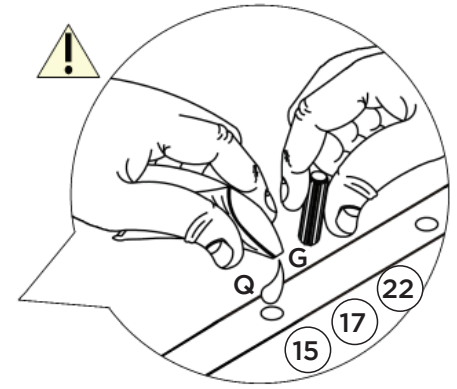
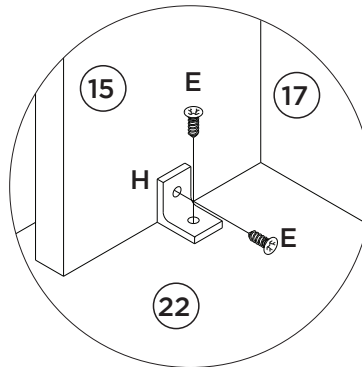
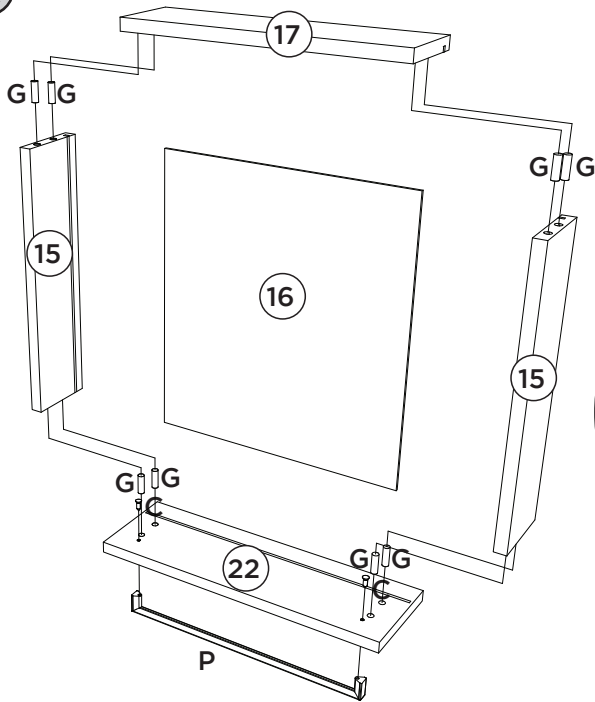

Fixar o Puxador (P) na Frente de Gaveta antes de colocar a peça (15).

Fije la Manija (P) en el Frente del Cajón antes de colocar la pieza (15).

Fix the Handle (P) on the Front of the Drawer before placing the part (15).

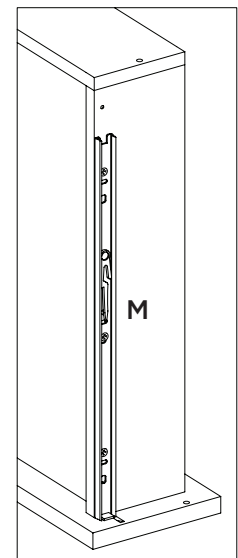

A corredeira (M) deverá ser alinhada com a parte de baixo do lado de gaveta (15)

La corredera (M) debe ser alineada con la parte de por el lado del cajón (15)

The slide (M) should be Aligned with the bottom Of the drawer side (15)

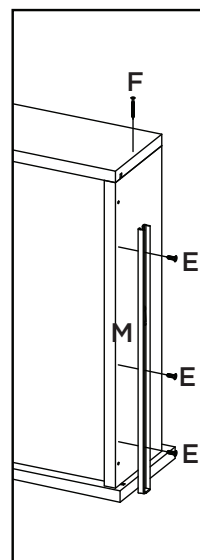
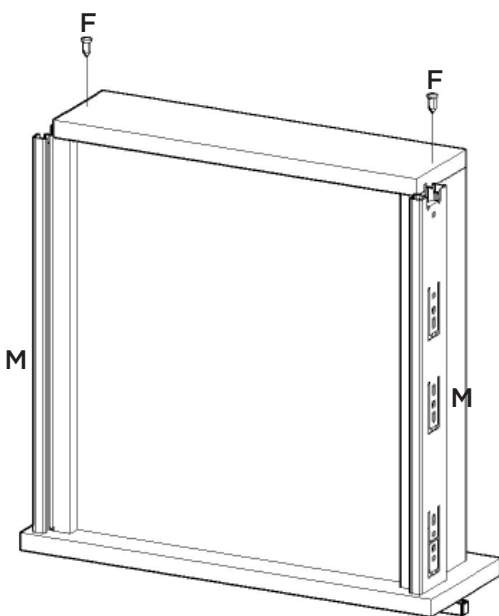

1X

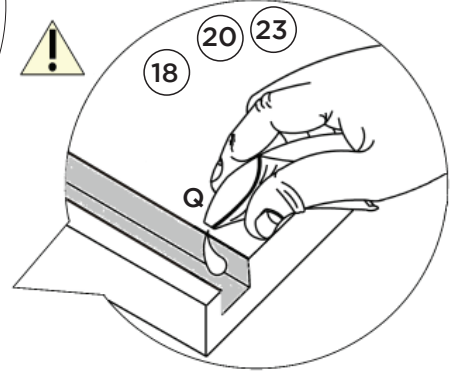
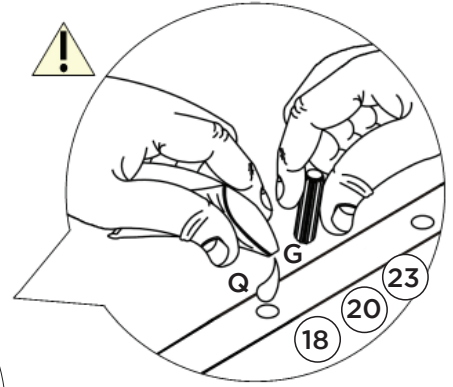
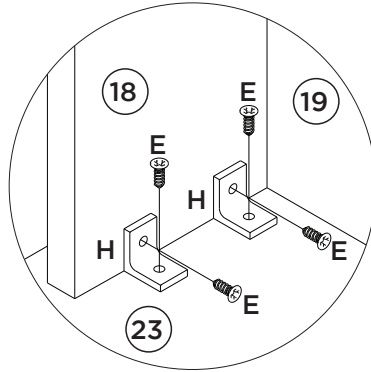
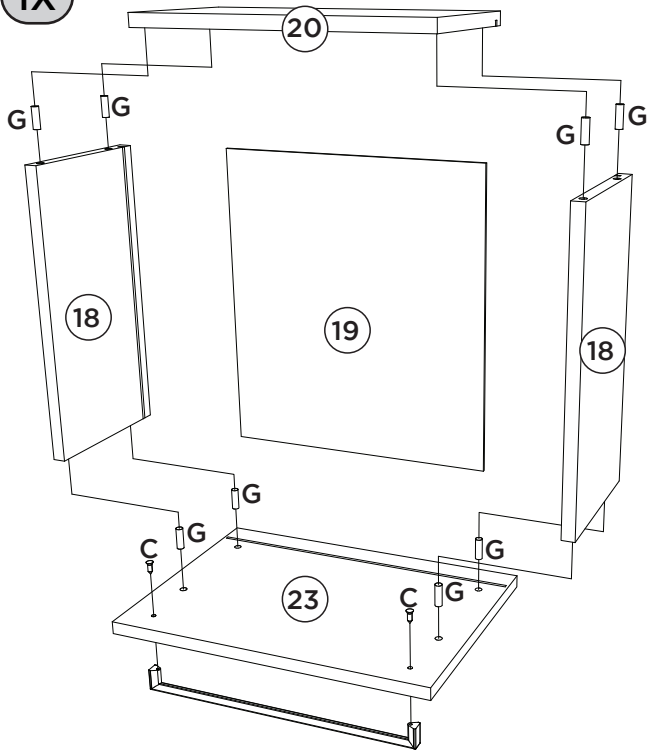

Fixar o Puxador (P) na Frente de Gaveta antes de colocar a peça (18).

Fije la Manija (P) en el Frente del Cajón antes de colocar la pieza (18).

Fix the Handle (P) on the Front of the Drawer before placing the part (18).

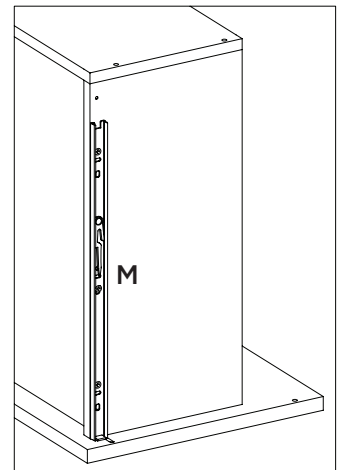

A corredeira (M) deverá ser alinhada com a parte de baixo do lado de gaveta (18)





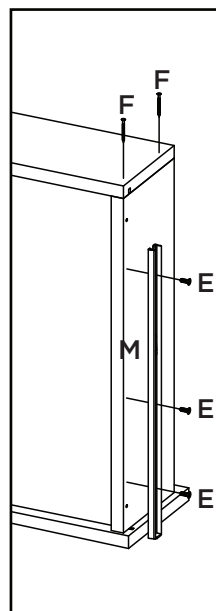
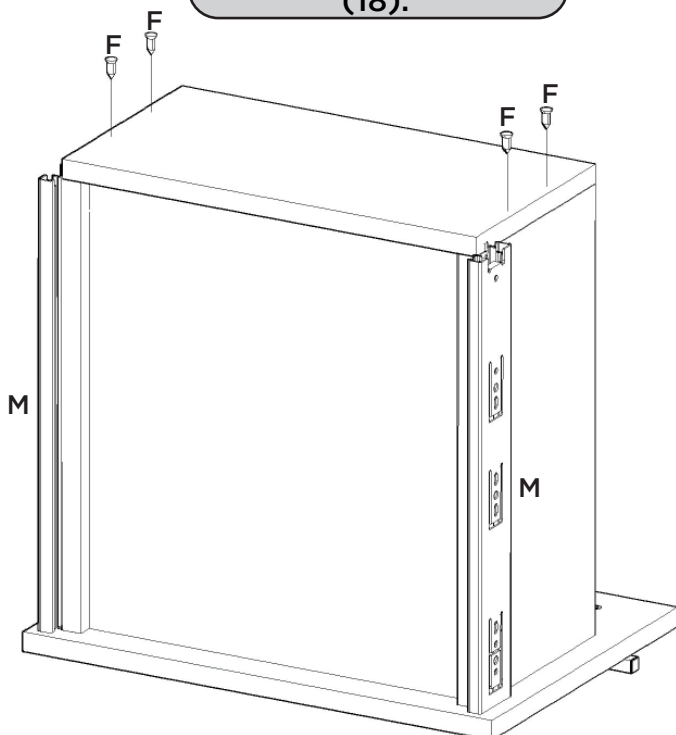







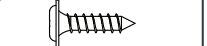

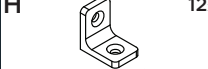

La corredera (M) debe ser alineada con la parte de por el lado del cajón (18)

The slide (M) should be Aligned with the bottom Of the drawer side (18)

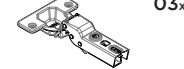

Item	Caixa Caja Box	Qty Ctd Qty	Descrição Descripción Description	Medidas (mm) Dimensions (mm) Size (measurements) (mm)
01	1/2	01	Lateral esquerda Lateral izquierda Left side	621x520x15
02	1/2	01	Rodapé frontal Pie delantero Front baseboard	369x73x15
03	1/2	01	Rodapé traseiro Pie trasero Rear baseboard	369x73x15
04	1/2	01	Lateral direita Lateral derecha Right side	621x520x15
05	1/2	01	Fundo 15mm Fondo 15mm 15mm Bottom	618x385x15
06	1/2	01	Tampo 25mm Tapa 25mm 25mm top	535x400x25
07	1/2	01	Prateleira central Estante central Central shelf	450x384x15
08	1/2	01	Base Aéreo Base Aérea Air Base	520x370x15
09	1/2	01	Lateral Maior Lateral Mayor Larger Lateral	1754x520x15
10	1/2	01	Lateral Direita Aéreo Lateral Derecha Aéreo Right Side Air	1136x520x15
11	1/2	01	Prateleira Estante Shelf	400x370x15
12	1/2	01	Tampo superior Tapa superior Top panel	520x370x15
13	1/2	01	Fundo Superior Fondo superior Superior background	1132x395x3
14	1/2	01	Fundo Cru Fondo crudo Raw Background	581x395x3
15	1/2	04	Lado de gaveta Lado del cajón Side of drawer	350x90x15
16=19	1/2	02	Fundo de gaveta Fondo del cajón Drawer bottom	361x325x3
17	1/2	02	Ripa de trás Malla detrás Rear lath	344x90x15
18	1/2	02	Lado de gaveta maior Lado del cajón mayor Largest drawer side	350x180x15
19=16	1/2	01	Fundo de gaveta Fondo del cajón Drawer bottom	361x325x3
20	1/2	01	Ripa de trás maior Malla detrás mayor Larger rear lath	344x180x15
21	2/2	01	Porta Puerta Door	1129x391x15
22	2/2	02	Frente de Gaveta Menor Frente de cajón más pequeño Smaller Drawer Front	392x127x15
23	2/2	01	Frente de Gaveta Maior Frente del cajón más grande Front of Larger Drawer	392x280x15

Ferragens | Herrajes | Hardware

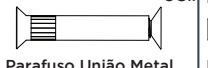
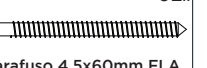
A	08x	B	16x	C	08x	D	26x	E	52x	F	08x	G	52x
													
Parafuso 4,5x50mm CHT. Tornillo 4,5x50mm CHT. Screw 4,5x50mm CHT.		Parafuso 3,5x40mm CHT. Tornillo 3,5x40mm CHT. Screw 3,5x40mm CHT.		Parafuso 3,5x22mm CHT. Tornillo 3,5x22mm CHT. Screw 3,5x22mm CHT.		Parafuso 3,5x14mm FLA. Tornillo 3,5x14mm FLA. Screw 3,5x14mm FLA.		Parafuso 3,5x12mm CHT. Tornillo 3,5x12mm CHT. Screw 3,5x12mm CHT.		Parafuso 3,0x30mm CHT. Tornillo 3,0x30mm CHT. Screw 3,0x30mm CHT.		Cavilha 8x25mm Cinta 8x25mm Dowel 8x25mm	
H	12x	I	04x	J	50x	K	08x	L	04x	M	03x	N	03x
													
Cantoneira plástica Cantonera plástica Plastic angle brackets		Prego 12x12mm Anelado Clavo 12x12mm Anillado Ringed Nails 12x12mm		Prego 10x10mm Clavo 10x10mm Nail 10x10mm		Porca cilíndrica Tuerca cilíndrica Cylindrical nut		Sapata "L" 16x20mm Zapata "L" 16x20mm "L" shoe 16x20mm		Corrediza telescópica Diapositivas telescópicas Telescopic slides		Dobradica SlideOn Alta Amort. 35mm Bisagra SlideOn Alta Amort. 35mm Hinge SlideOn High damper 35mm	
O	03x	P	04x	Q	02x	R	34x	S	05x	T	02x		
													
Calço Removível Calzado extraíble Removable Shim		Puxador Aleno Fit 300mm Tirador Aleno Fit 300mm Handle Aleno Fit 300mm		Sachê de cola Bolsa de pegamento Glue bag		Adesivo tapa parafuso 10mm Adhesivo tapón de tornillo 10mm Bolt cover adhesive 10mm		Parafuso União Metal Tornillo Unión Metal Metal Union Screw		Parafuso 4,5x60mm FLA. Tornillo 4,5x60mm FLA. Screw 4,5x60mm FLA.			

A união (S) deve ser usada somente quando este módulo for acoplado a outro módulo componível Henn, para unir duas peças de 15mm. Caso ele seja usado separadamente, a utilização do união não se faz necessário.

La unión (S) se debe utilizar sólo cuando el módulo está acoplado a otro módulo composable Henn, para unirse a dos 15mm piezas. Si se utiliza por separado, el uso de unión no es necesario.

The union (S) should be used only when this module is coupled to another Module Henn, to join two pieces of 15mm. If it is used separately, the use of the union is not necessary.

HENN

Ind. e Com. de Móveis Henn
Mondai - SC - Brasil

+55 49 3674.3500

@moveishenn
www.henn.com.br

INSTRUÇÕES DE MONTAGEM

INSTRUCCIONES DE MONTAJE
ASSEMBLY INSTRUCTIONS

Ponte Casal 4 Portas Seletto

Puente Casal 4 Puertas Seletto | Casal Bridge 4 Doors Seletto

c MC11-133 Areia HP

c MC11-184 Areia HP/Jequitibá

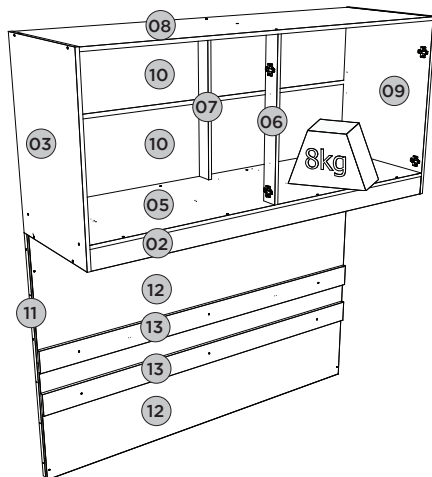
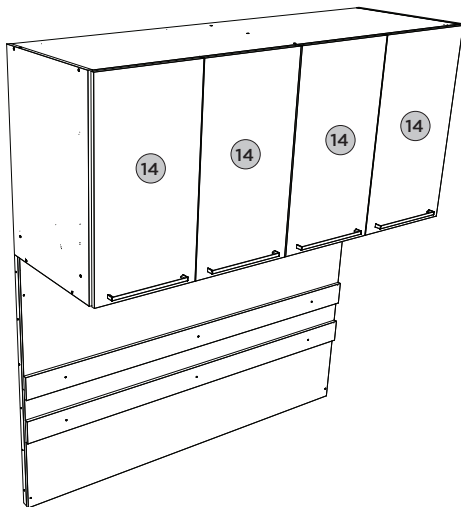

Requisitos para montagem Requisitor para la montaje Assembly Requirements

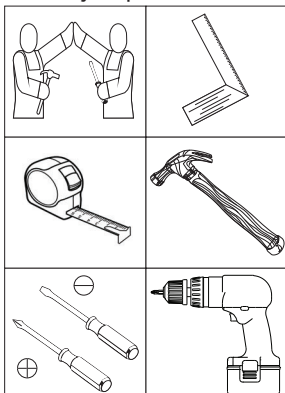

Imagens meramente ilustrativas
Imágenes meramente ilustrativas
Images for illustration only

Pesos máximos recomendados com carga distribuída
Peso máximo recomendado con la carga distribuída
Recommended maximum weights with evenly distributed.

AVISO

Para limpeza de seu móvel, use uma flanela seca ou umedecida, e não utilize produtos químicos que possam danificar seu produto.

SISTEMA DE MONTAGEM

O sistema de montagem dos produtos, funciona de acordo com a ordem crescente dos números indicados no desenho. Ex: 01, 02, 03, 04... até a conclusão da montagem.

ADVERTENCIA

Para limpieza de su móvil, use una flanela seca o húmeda, y no utilice productos químicos que puedan dañar su producto.

SISTEMA DE MONTAJE

El sistema de montaje de los productos funciona de acuerdo con el orden creciente de los números indicados en el dibujo. Ej.: 01, 02, 03, 04... hasta la conclusión del montaje.

NOTICE

To clean your furniture, use a dry or wet cloth, and do not use chemicals that may damage your product.

ASSEMBLY SYSTEM

The products' assembly system works according to the increasing order of the indicated numbers. For example: 01, 02, 03, 04 ... to the end of the assembly.

1

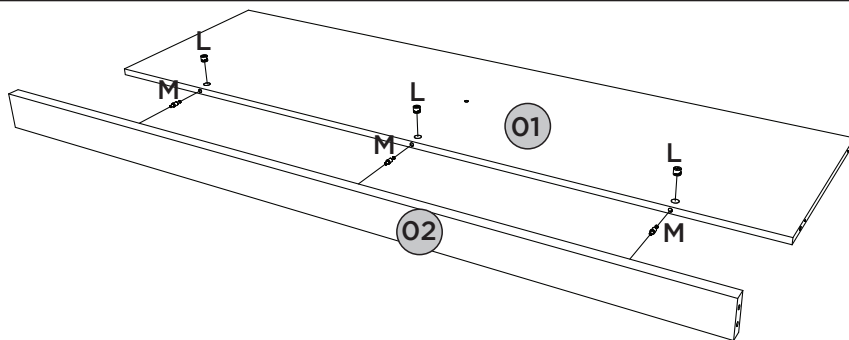

2

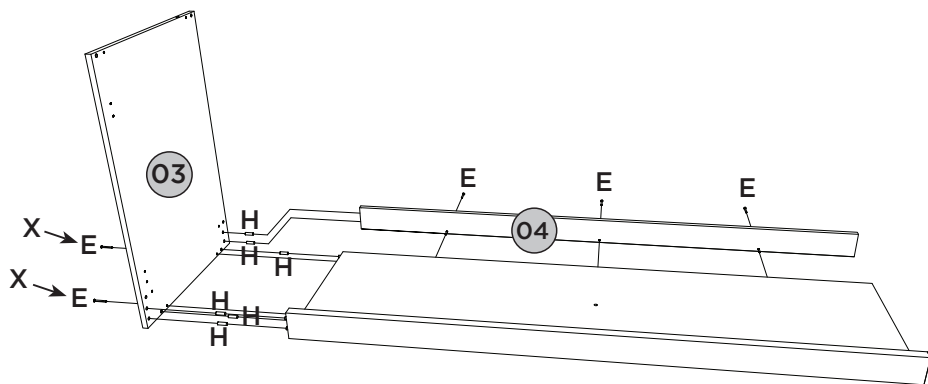

3

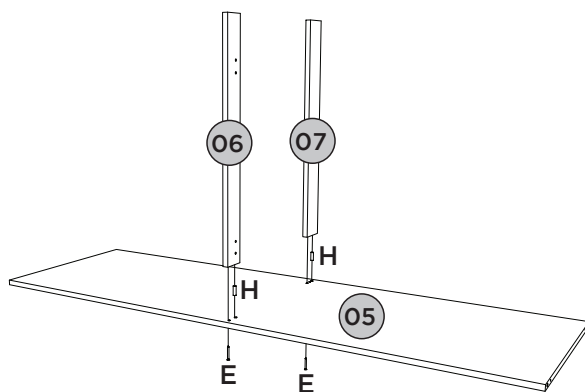

4

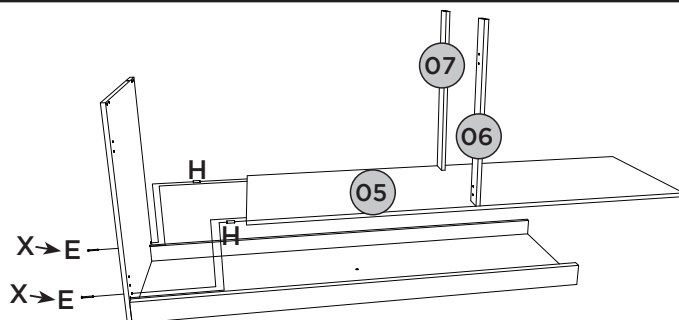

5

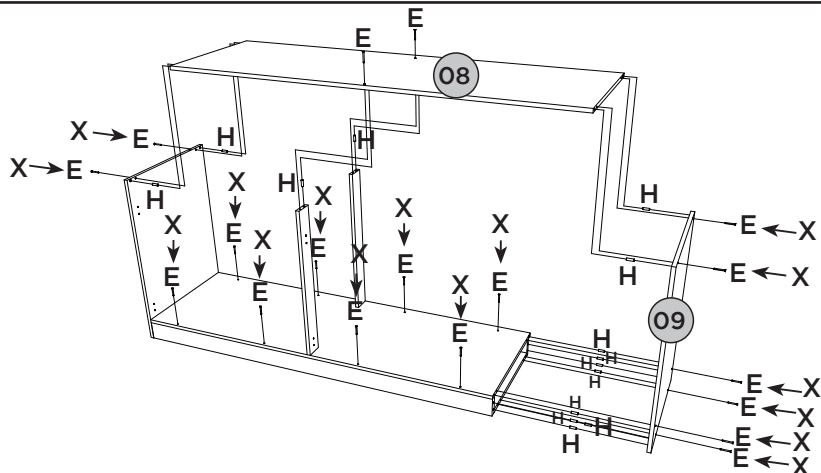

6

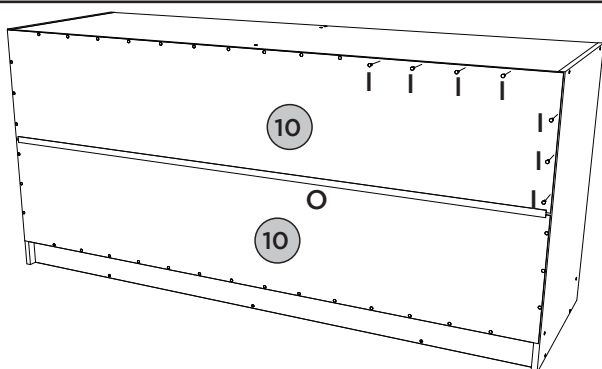

7

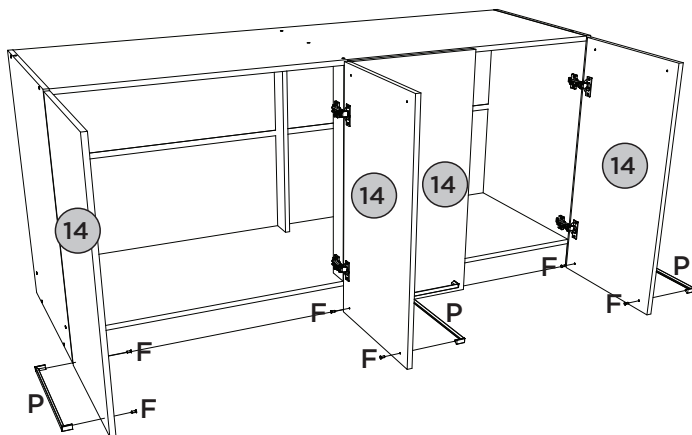
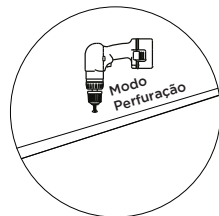
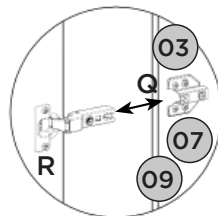
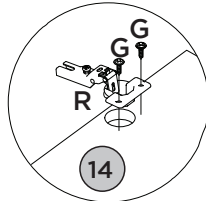
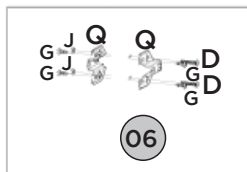
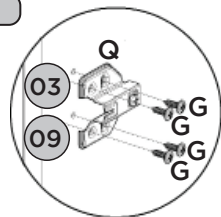

Fazer furação passante para fixar os puxadores, utilizando as pré marcações existentes nas portas.

Taladre agujeros para fijar las manijas, utilizando las marcas previas en las puertas.

Drill through holes to fix the handles, using the pre-markings on the doors.

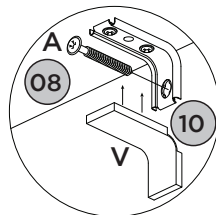
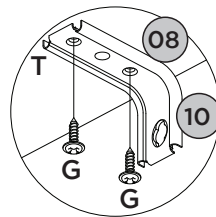
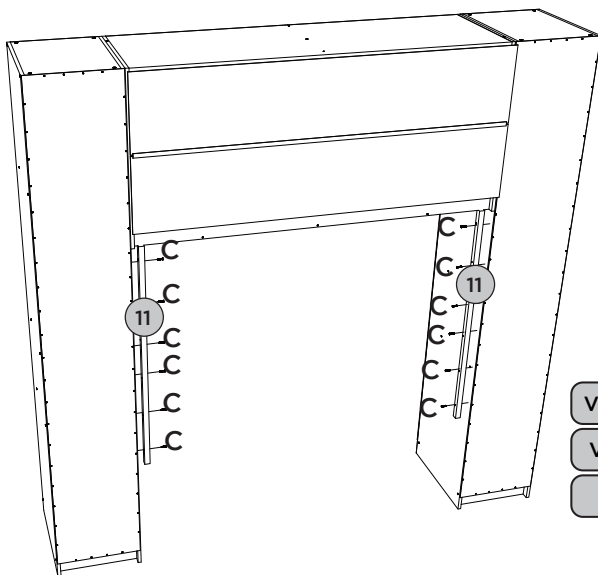

Vista Traseira

Vista trasera

Back view



Mesa Cabeceira Seletto 1Pt 3Gav.

Mesita De Noche Seletto 1Pt 3Gav.

Bedside Table Seletto 1Pt 3Gav.

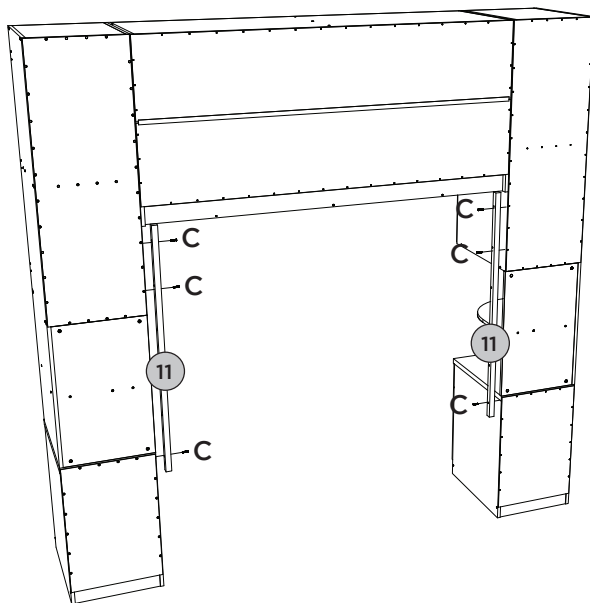

Para simulação de montagem dos fundos foram utilizados móveis componíveis da mesma linha.

Para la simulación de montaje de fondos se utilizaron muebles composable la misma línea.

For simulation of assembly of the funds were used furniture of the same line.

Para a colocação dos apoios estruturais (11) fazer o alinhamento dos mesmos com a parte de trás da lateral dos móveis ao lado.

Para la colocación del soporte estructural (11) del mismo a alinear con el lado posterior de la parte móvil.

For the placement of the supports Structural Funds (11) to aligning them with the back side of the furniture next to it.

9

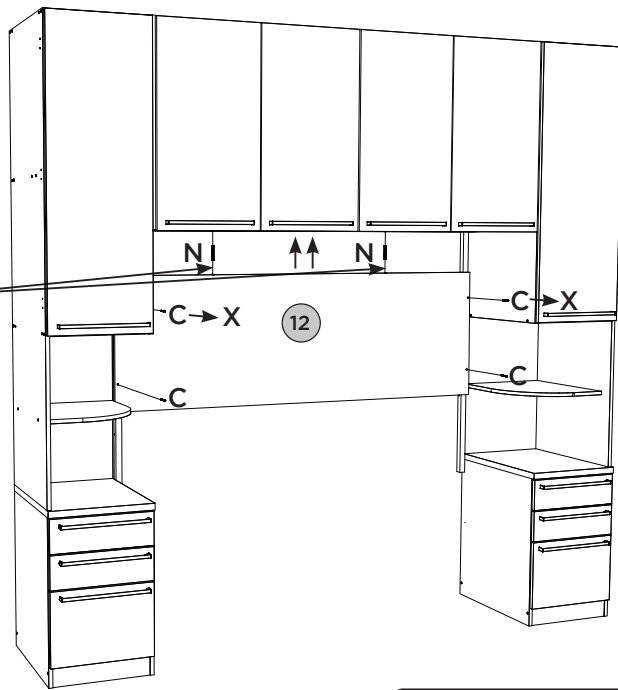
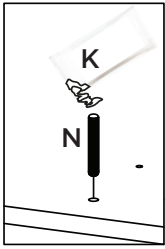

Mesa Cabeceira Seletto 1Pt 3Gav.

Mesita De Noche Seletto 1Pt 3Gav.

Bedside Table Seletto 1Pt 3Gav.

10

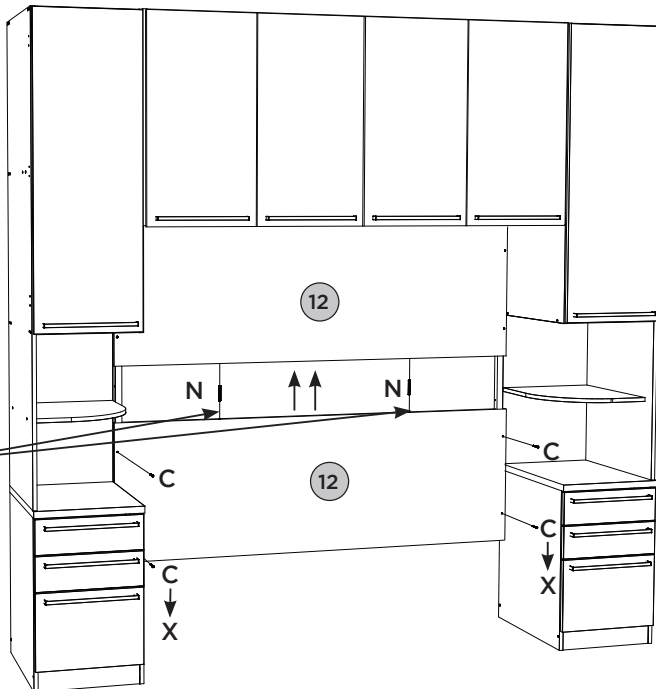
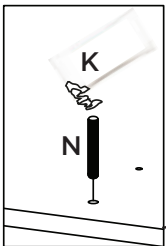

11

Colocação dos apliques nos fundos.

La colocación de los apliques en fondos.

Placement of the appliques in the back.

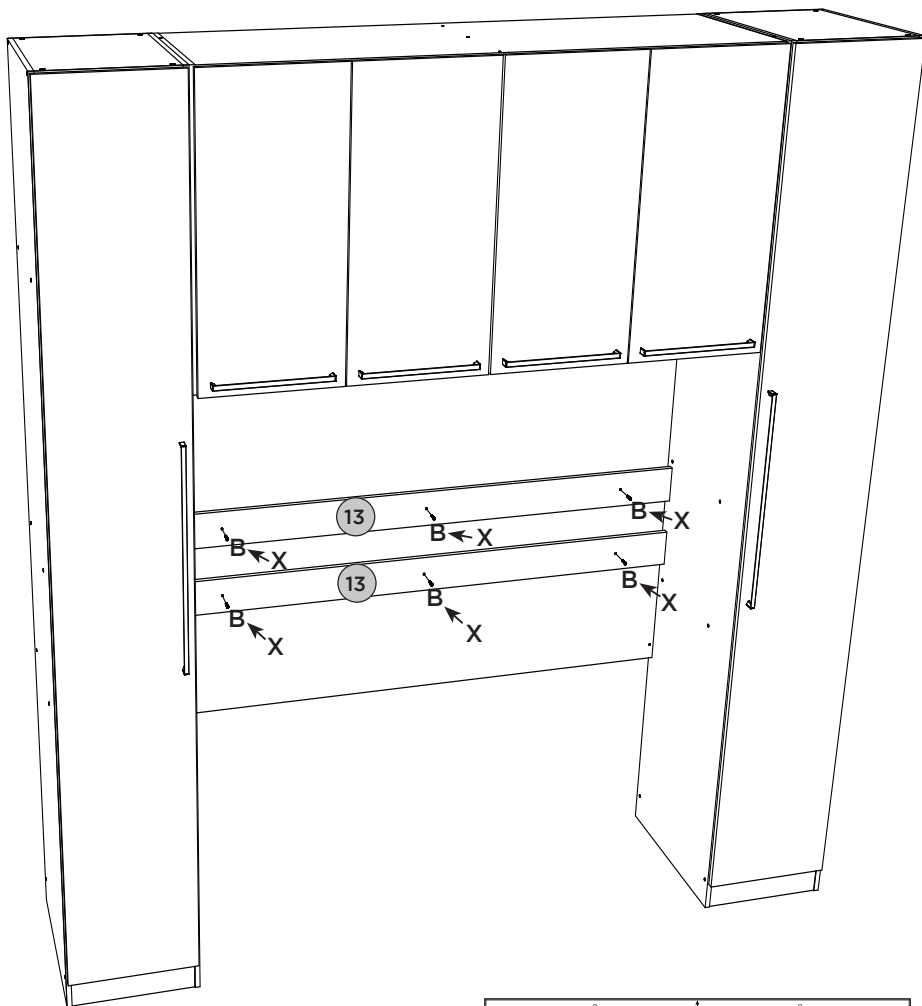

Medidas recomendadas para a colocação dos apliques nos fundos.

Medidas recomendadas para la colocación de accesorios en los fondos.

Recommended measures for the placement of the appliques on the back.

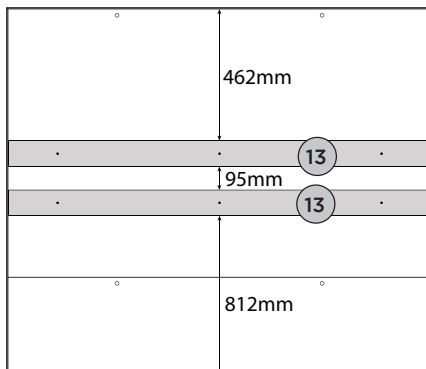

12



Opção com Mesa de Cabeceira.

Opción con Mesita de Noche.

Option with Bedside Table.

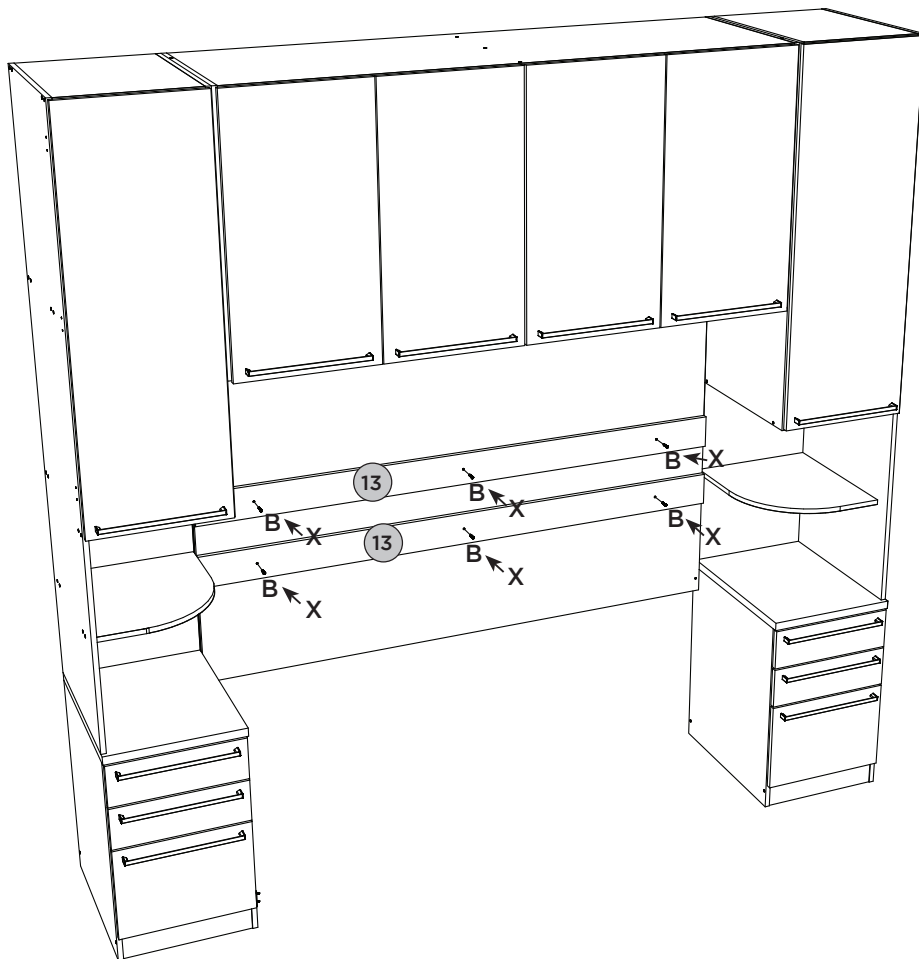

Medidas recomendadas para a colocação dos apliques nos fundos.





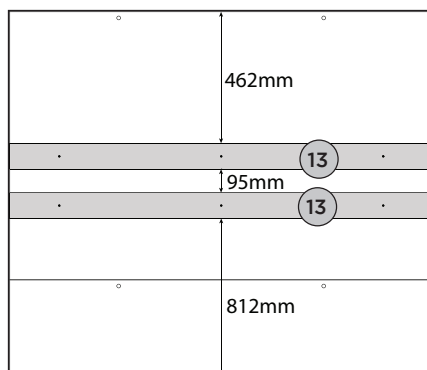





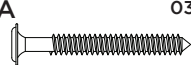







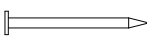

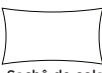

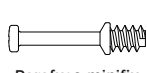
Medidas recomendadas para la colocación de accesorios en los fondos.

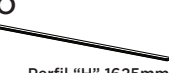
Recommended measures for the placement of the appliques on the back.

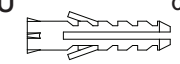
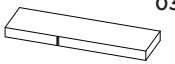

Item	Caixa Caja Box	Qtd Ctd Qty	Descrição Descripción Description	Medidas (mm) Dimensions (mm) Size (measurements) (mm)
01	1/3	01	Base Base Base	1620x454x15
02	2/3	01	Travessa Frontal Travesaño delantero Front Tray	1620x80x25
03	1/3	01	Lateral esquerda Lateral izquierda Left side	760x520x15
04	2/3	01	Travessa Traseira travesaño trasero Rear Tray	1620x80x15
05	1/3	01	Base Interna Base interna Internal Base	1620x520x15
06	2/3	01	Pilastra da Porta Puerta pilastra Door Pilaster	649x70x15
07	2/3	01	Pilastra Pilastra Pilaster	649x70x15
08	1/3	01	Tampo Tapa Top	1620x520x15
09	1/3	01	Lateral direita Lateral derecha Right side	760x520x15
10	2/3	02	Fundo Fondo Bottom	1645x335x3
11	2/3	02	Apoio estrutural Apoyo estructural Structural support	1092x25x25
12	2/3	02	Fundo 15mm Fondo 15mm 15mm Bottom	1650x546x15
13	1/3	02	Aplique Aplique Apply	1650x100x15
14	3/3	04	Porta Puerta Door	760x405x15

Ferragens | Herrajes | Hardware

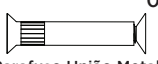
A  Parafuso 5,0x50mm FLA. Tornillo 5,0x50mm FLA. Screw 5,0x50mm FLA.	B  Parafuso 4,0x25mm CHT. Tornillo 4,0x25mm CHT. Screw 4,0x25mm CHT.	C  Parafuso 4,0x35mm CHT. Tornillo 4,0x35mm CHT. Screw 4,0x35mm CHT.	D  Parafuso 4,0x25mm MET FLA. Tornillo 4,0x25mm MET FLA. Screw 4,0x25mm MET FLA.	E  Parafuso 3,5x40mm CHT. Tornillo 3,5x40mm CHT. Screw 3,5x40mm CHT.
F  Parafuso 3,5x22mm CHT. Tornillo 3,5x22mm CHT. Screw 3,5x22mm CHT.	G  Parafuso 3,5x14mm FLA. Tornillo 3,5x14mm FLA. Screw 3,5x14mm FLA.	H  Cavilha 8x25mm Cinta 8x25mm Dowel 8x25mm	I  Prego 10x10mm Clavo 10x10mm Nail 10x10mm	J  Porca Sextavada Tuerca Hexagonal Hexagon Nut
K  Sachê de cola Bolsa de pegamento Glue bag	L  Tambor minifix Tambor minifix Minifix drum	M  Parafuso minifix Tornillo minifix Minifix bolt	N  Cavilha 8x60mm Cinta 8x60mm Dowel 8x60mm	O  Perfil "H" 1625mm Perfil "H" 1625mm Profile "H" 1625mm
P  Puxador Aleno Fit Alumínio Mango de alumínio Aleno Fit Aleno Fit Aluminum Handle	Q  Calço Removível Calzado extraíble Removable Shim	R  Dobradiça SlideOn Alta Amort. 35mm Bisagra SlideOn Alta Amort. 35mm Hinge SlideOn High damper 35mm	S  Etiqueta resinada Henn Etiqueta resinada Henn Henn resin label	T  Suporte de fixação Soporte de fijación Mounting bracket
U  Bucha plástica 8mm Bucha de plástico 8mm 8mm plastic bushing	V  Proteção para cantoneira Ángulo de protección Protection angle	W  Giz de correção Tiza de corrección Chalk of correction	X  Adesivo tapa parafuso 10mm Adhesivo tapón de tornillo 10mm Bolt cover adhesive 10mm	Y  Parafuso União Metal Tornillo Unión Metal Metal Union Screw

A união (Y) deve ser usada somente quando este módulo for acoplado a outro módulo componível Henn, para unir duas peças de 15mm. Caso ele seja usado separadamente, a utilização do união não se faz necessário.

La unión (Y) se debe utilizar sólo cuando el módulo está acoplado a otro módulo composable Henn, para unirse a dos 15mm piezas. Si se utiliza por separado, el uso de unión no es necesario.

The union (Y) should be used only when this module is coupled to another Module Henn, to join two pieces of 15mm. If it is used separately, the use of the union is not necessary.

RECOMENDAÇÃO

Para fixar o móvel na parede usar o suporte de fixação (T), o parafuso 3,5x14mm FLA (G), a Bucha 8mm (U) e o parafuso 5,0x50mm FLA (A)

RECOMENDACIÓN

Para conectar el móvil a la pared con el soporte (T), tornillo 3,5x14mm FLA (G), el casquillo de 8 mm (U) y el 5,0x50mm tornillo FLA (A).

RECOMMENDATION

To connect the mobile to the wall with the bracket (T), screw 3.5x14mm FLA (G), the socket 8mm (U) and the 5.0x50mm screw FLA (A).