

| Item  | Caixa<br>Caja<br>Box | Qty<br>Ctd<br>Qty | Descrição  <br>Descripción  <br>Description                               | Medidas (mm)  <br>Dimensions (mm)  <br>Size (measurements) (mm) |
|-------|----------------------|-------------------|---|---|
| 01    | 1/1                  | 01                | Base   Base   Base  | 1200x490x15   |
| 02    | 1/1                  | 01                | Lateral esquerda   Lateral izquierda   Left side                          | 715x490x15  |
| 03    | 1/1                  | 01                | Divisão   División   Division   | 655x490x15  |
| 04    | 1/1                  | 01                | Prateleira   Estante   Shelf  | 784x400x15  |
| 05    | 1/1                  | 01                | Travessa frontal   Travesaño frontal   Front crossbar                     | 1169x60x15  |
| 06    | 1/1                  | 01                | Travessa traseira   Travesaño trasero   Rear bumper                       | 1169x60x15  |
| 07    | 1/1                  | 01                | Lateral direita   Lateral derecha   Right side                            | 715x490x15  |
| 08    | 1/1                  | 01                | Pilastra da Porta   Pilastra Puerta   Pilaster door                       | 654x60x15   |
| 09    | 1/1                  | 01                | Fundo menor   Fondo menor   Minor fund                                    | 727x389x3   |
| 10    | 1/1                  | 02                | Fundo maior   Fondo mayor   Greater Fund                                  | 803x363x3   |
| 11    | 1/1                  | 02                | Porta   Puerta   Door   | 680x396x15  |
| 12    | 1/1                  | 01                | Frente de Gaveta Maior   Frente de cajón más grande   Larger Drawer Front | 396x326x15  |
| 13    | 1/1                  | 02                | Lado de gaveta Maior   Lado del cajón más grande   Larger drawer side     | 400x180x15  |
| 14=18 | 1/1                  | 01                | Fundo de gaveta   Fondo de cajón   Bottom of drawer                       | 411x326x3   |
| 15    | 1/1                  | 01                | Ripa de Trás Maior   Tablilla trasera más grande   Larger rear clapboard  | 345x180x15  |
| 16    | 1/1                  | 02                | Frente de gaveta   Frente de cajón   Front of drawer                      | 396x149x15  |
| 17    | 1/1                  | 04                | Lado de Gaveta   Lado del cajón   Drawer Side                             | 400x90x15   |
| 18=14 | 1/1                  | 02                | Fundo de gaveta   Fondo de cajón   Bottom of drawer                       | 411x326x3   |
| 19    | 1/1                  | 02                | Ripa de trás   Malla detrás   Rear lath                                   | 345x90x15   |
| 20    | 1/1                  | 01                | Travessa Sustentação   Travessa Ayuda   Support Travessa                  | 1190x50x15  |



Ind. e Com. de Móveis Henn  
Mondai - SC - Brasil  
+55 49 3674.3500  
@moveishenn  
www.henn.com.br

# INSTRUÇÕES DE MONTAGEM

INSTRUCCIONES DE MONTAJE  
ASSEMBLY INSTRUCTIONS

## Balcão Pia 02 Portas 03 Gavetas Belize Fregadero 02 Puertas 03 Cajones Belize | Counter Sink 02 Doors 03 Drawers Belize

### C508-131 Cinza C508-170 Capuccino HP

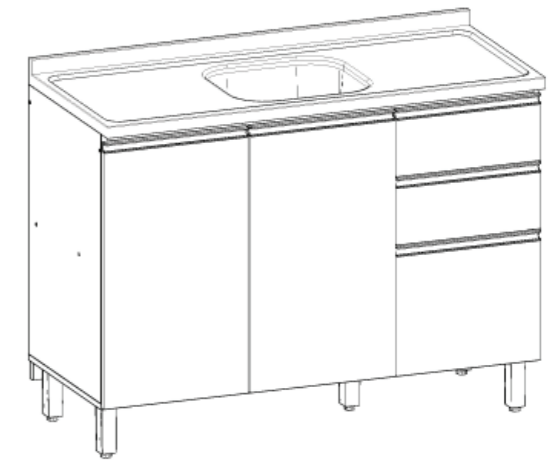
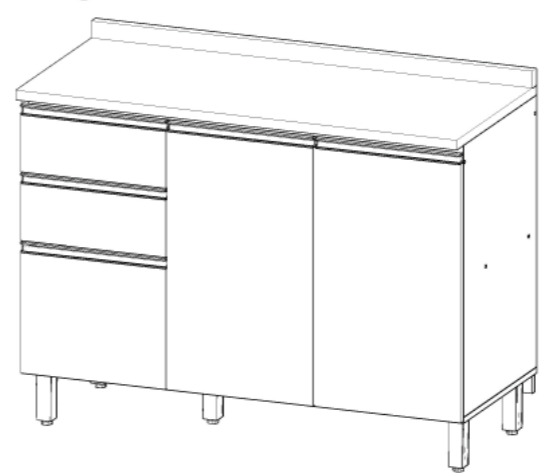
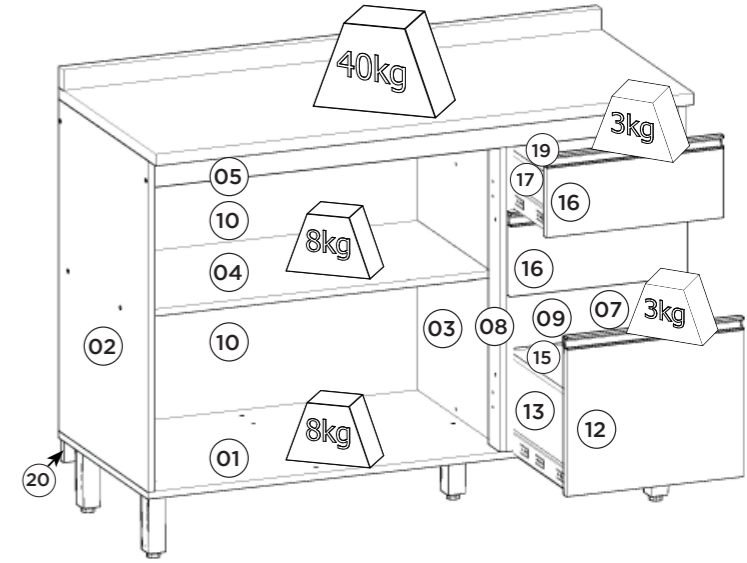
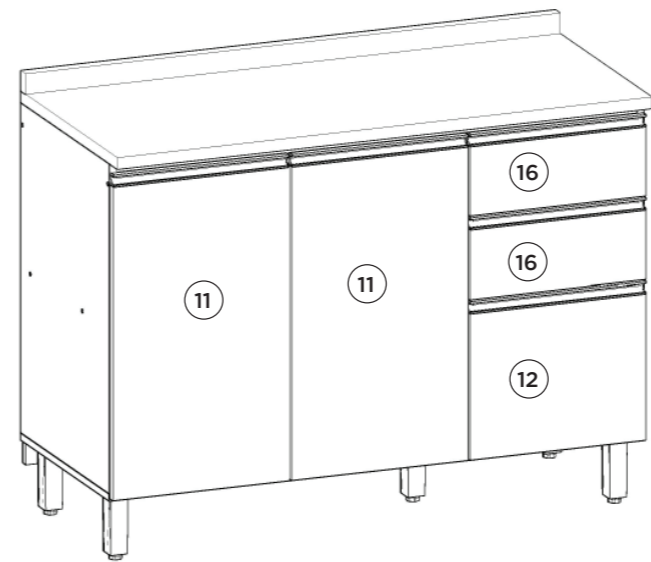

Pesos máximos recomendados com carga distribuída  
Peso máximo recomendado con la carga distribuída  
Recommended maximum weights with evenly distributed.

#### Ferragens | Herrajes | Hardware

|   |   |  |  |  |   |
|---|---|--|--|--|---|
| <b>A</b><br>Parafuso 7,0x40mm CHT.<br>Tornillo 7,0x40mm CHT.<br>Screw 7,0x40mm CHT. | <b>B</b><br>Parafuso 5,0x50mm FLA.<br>Tornillo 5,0x50mm FLA.<br>Screw 5,0x50mm FLA. | <b>C</b><br>Parafuso 4,5x50mm CHT.<br>Tornillo 4,5x50mm CHT.<br>Screw 4,5x50mm CHT.                    | <b>D</b><br>Parafuso 4,0x25mm CHT.<br>Tornillo 4,0x25mm CHT.<br>Screw 4,0x25mm CHT.                    | <b>E</b><br>Parafuso 3,5x40mm CHT.<br>Tornillo 3,5x40mm CHT.<br>Screw 3,5x40mm CHT.  | <b>F</b><br>Parafuso 3,5x14mm FLA.<br>Tornillo 3,5x14mm FLA.<br>Screw 3,5x14mm FLA. |
| <b>G</b><br>Parafuso 3,5x12mm CHT.<br>Tornillo 3,5x12mm CHT.<br>Screw 3,5x12mm CHT. | <b>H</b><br>Parafuso 3,0x30mm CHT.<br>Tornillo 3,0x30mm CHT.<br>Screw 3,0x30mm CHT. | <b>I</b><br>Prego 10x10mm<br>Clavo 10x10mm<br>Nail 10x10mm   | <b>J</b><br>Fixador de fundos<br>Fijador de fondos<br>Bottom fixer                                     | <b>K</b><br>Cavilha 8x25mm<br>Cinta 8x25mm<br>Dowel 8x25mm   | <b>L</b><br>Parafuso minifix<br>Tornillo minifix<br>Minifix bolt                    |
| <b>M</b><br>Tambor minifix<br>Tambor minifix<br>Minifix drum                        | <b>N</b><br>Pé 145mm x 42mm<br>Pie 145mm x 42mm<br>Foot 145mm x 42mm                | <b>O</b><br>Cantoneira plástica<br>Cantenera plástica<br>Plastic angle brackets                        | <b>P</b><br>Calço Removível<br>Calzado extraíble<br>Removable Shim                                     | <b>Q</b><br>Dobradilha SlideOn Baixa Amortecedor 35mm<br>Bisagra SlideOn Baja Amortiguador 35mm<br>Low SlideOn Hinge 35mm Shock Absorber | <b>R</b><br>Puxador 396mm<br>Tirador 396mm<br>396mm Handle                          |
| <b>S</b><br>Corrediça telescópica<br>Diapositivas telescópicas<br>Telescopic slides | <b>T</b><br>Parafuso União 30mm<br>Tornillo Unión 30mm<br>Union Screw 30mm          | <b>U</b><br>Bucha plástica 8mm<br>Bucha de plástico 8mm<br>8mm plastic bushing                         | <b>V</b><br>Divisor talheres 398x313mm<br>Divisor cubiertos 398x313mm<br>Cutlery divider 398x313mm     | <b>W</b><br>Sachê de cola<br>Bolsa de pegamento<br>Glue bag  | <b>X</b><br>Giz de correção<br>Tiza de corrección<br>Chalk of correction            |
| <b>Y</b><br>Suporte de fixação<br>Soporte de fijación<br>Mounting bracket           | <b>Z</b><br>Proteção para cantoneira<br>Ángulo de protección<br>Protection angle    | <b>AA</b><br>Adesivo tapa parafuso 17mm<br>Adhesivo tapón de tornillo 17mm<br>Bolt cover adhesive 17mm | <b>AB</b><br>Adesivo tapa parafuso 10mm<br>Adhesivo tapón de tornillo 10mm<br>Bolt cover adhesive 10mm | <b>AC</b><br>Etiqueta resinada Henn<br>Etiqueta resinada Henn<br>Henn resin label  | <b>AD</b><br>Batente PVC para Porta<br>Parada de PVC para Puerta<br>PVC Door Stop   |

#### Requisitos para montagem Requisitor para la montaje Assembly Requirements

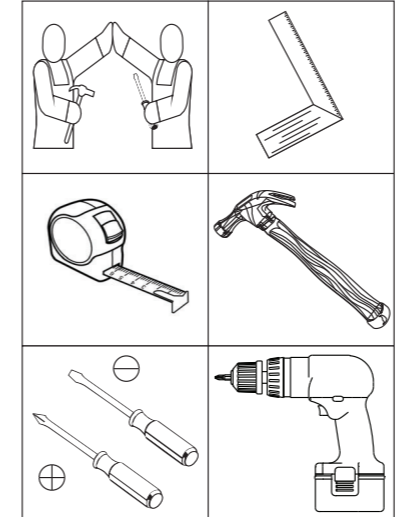

Imagens meramente ilustrativas  
Imágenes meramente ilustrativas  
Images for illustration only

#### RECOMENDAÇÃO

Para fixar o móvel na parede usar o suporte de fixação (Y), o parafuso 3,5x14mm FLA (F), a Bucha 8mm (U) e o parafuso 5,0x50mm FLA (B).

#### RECOMENDACIÓN

Para conectar el móvil a la pared con el soporte (Y), tornillo 3,5 x14mm FLA (F), el casquillo de 8 mm (U) y el 5,0 x50mm tornillo FLA (B).

#### RECOMMENDATION

To fix the furniture to the wall use the mounting bracket (Y), the 3.5x14mm FLA (F) screw, the 8mm bushing (U) and the 5.0x50mm FLA (B) screw.

#### AVISO

Para limpeza de seu móvel, use uma flanela seca ou umedecida, e não utilize produtos químicos que possam danificar seu produto.

#### SISTEMA DE MONTAGEM

O sistema de montagem dos produtos, funciona de acordo com a ordem crescente dos números indicados no desenho. Ex: 01, 02, 03, 04... até a conclusão da montagem.

#### ADVERTENCIA

Para limpieza de su móvil, use una flanela seca o húmeda, y no utilice productos químicos que puedan dañar su producto.

#### SISTEMA DE MONTAJE

El sistema de montaje de los productos funciona de acuerdo con el orden creciente de los números indicados en el dibujo. Ej.: 01, 02, 03, 04... hasta la conclusión del montaje.

#### NOTICE

To clean your furniture, use a dry or wet cloth, and do not use chemicals that may damage your product.

#### ASSEMBLY SYSTEM

The products' assembly system works according to the increasing order of the indicated numbers. For example: 01, 02, 03, 04 ... to the end of the assembly.

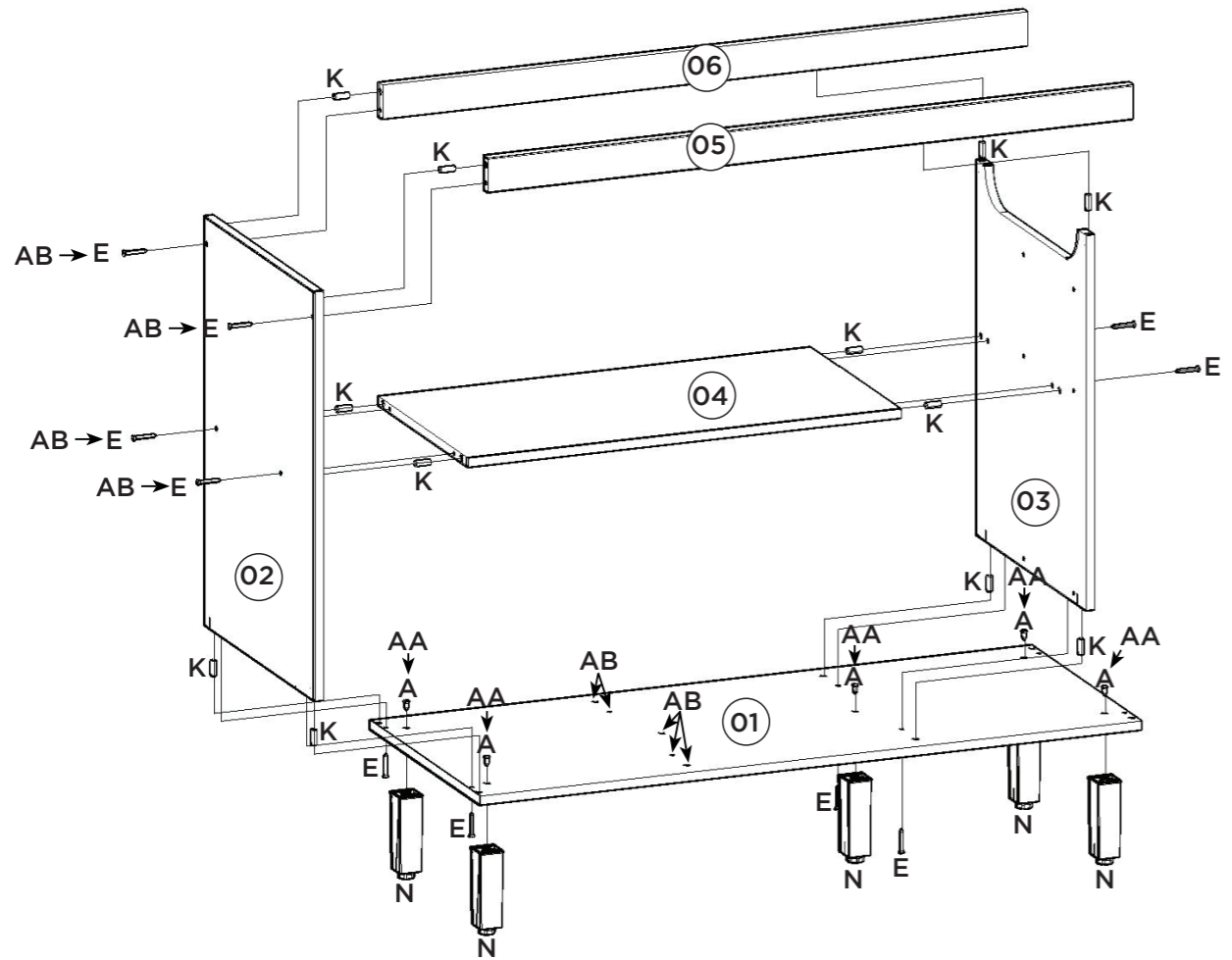

Utilizar o sachê de cola (W) em todas as cavilhas (K) do produto.

Con el pegamento sobre (W) en todos los pernos (K) producto.

Use the glue sachet (W) on all the pegs (K) of the product.

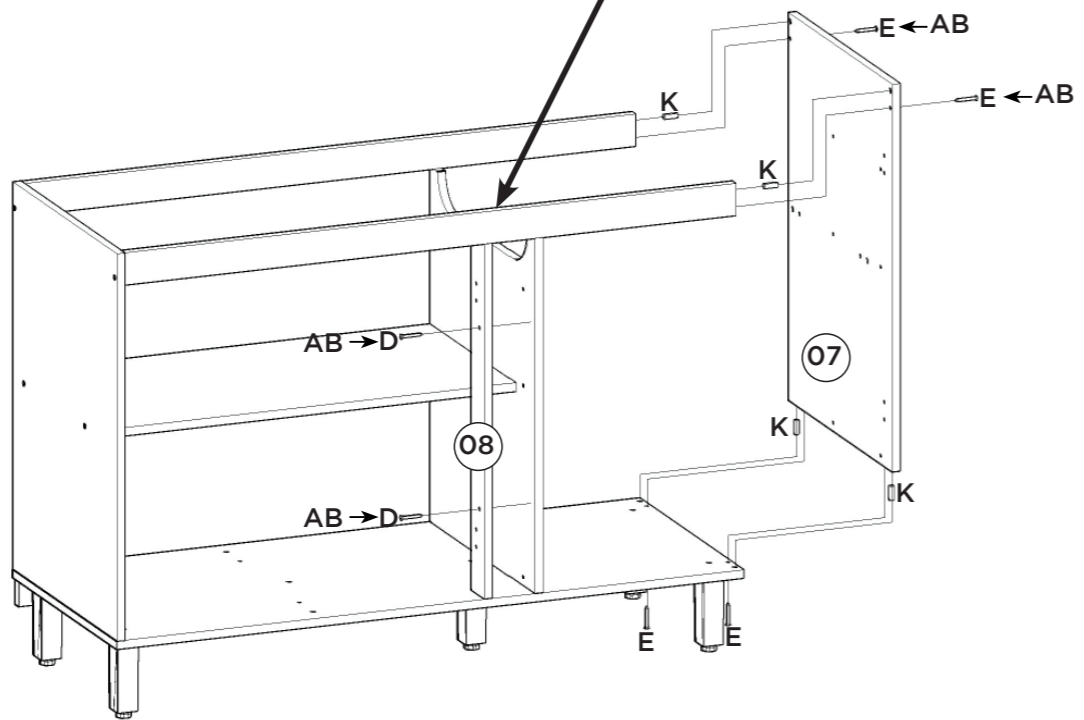
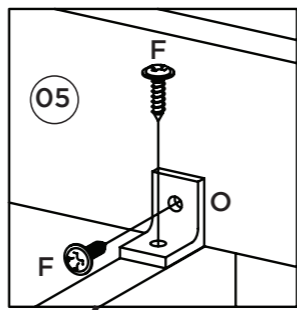
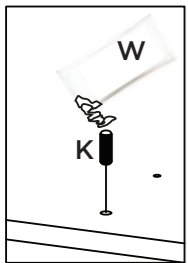

A pilastra da porta (08) deve estar alinhada com a divisão (03).

El pilar de la puerta (08) debe estar alineada con la división (03).

The door pillar (08) must be aligned with the partition (03).

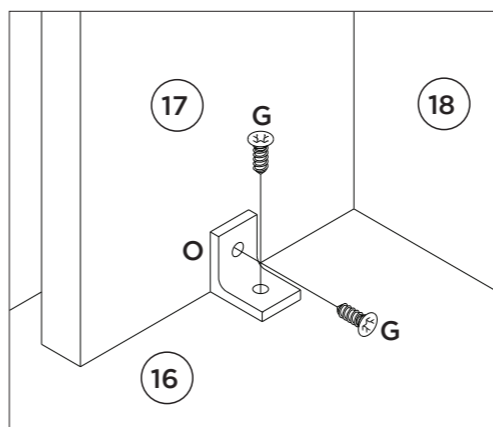
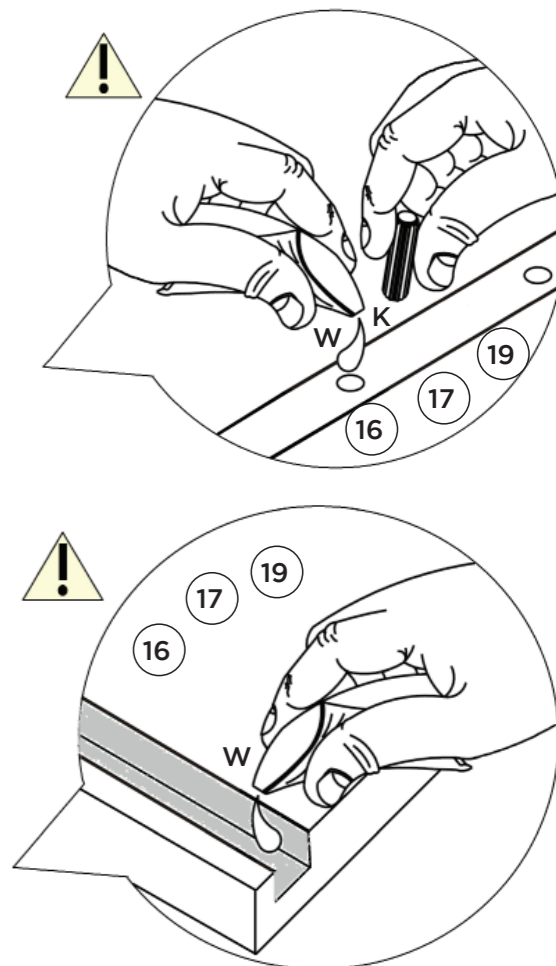
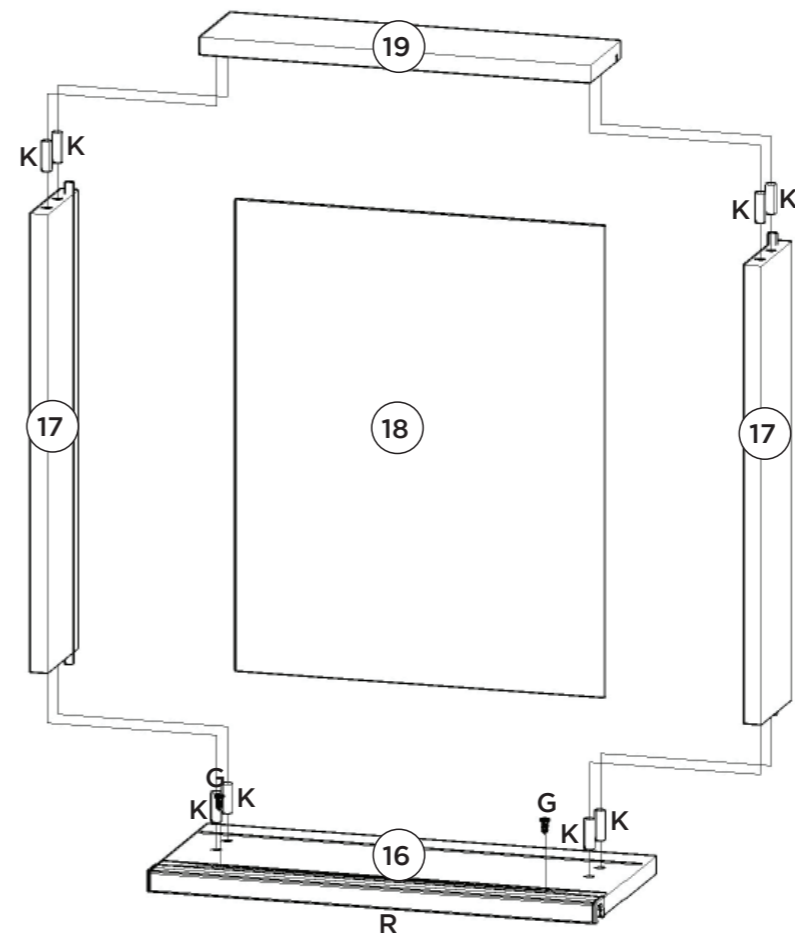

A corrediça (S) deverá ser alinhada com a parte de baixo do lado de gaveta (17).

La carcasa (S) será alineada con la parte de por el lado del cajón (17).

The slide (S) should be aligned with the underside of the drawer side (17).

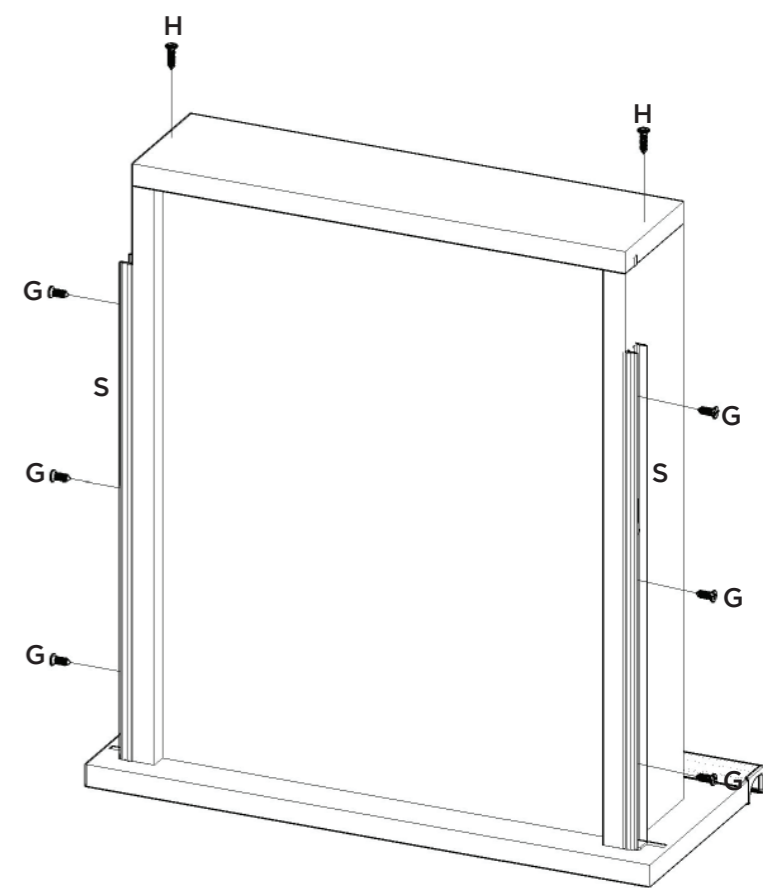

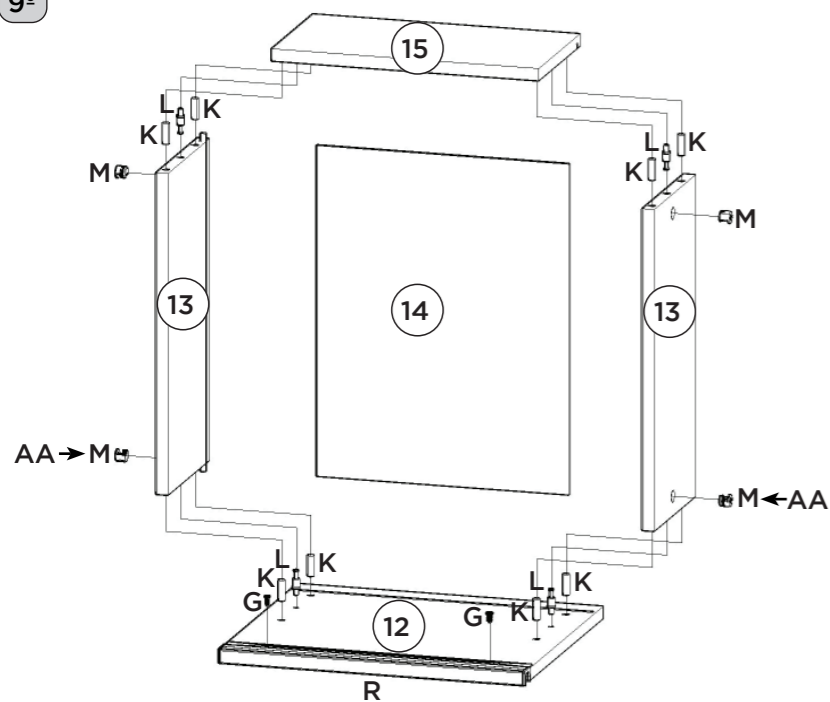
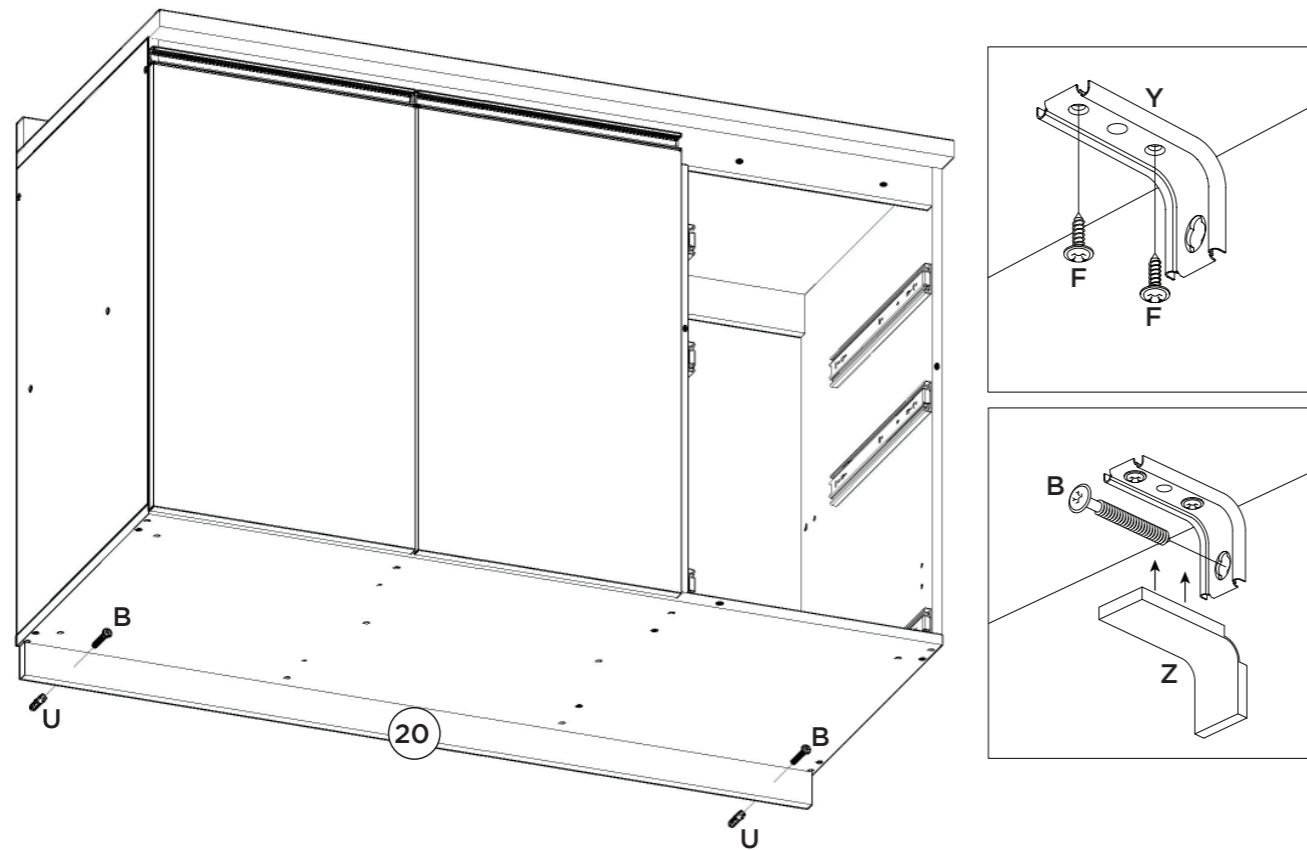
Parede  
pared  
Wall

A corredeira (S) deverá ser alinhada com a parte de baixo do lado de gaveta (13).

La carcasa (S) será alineada con la parte de por el lado del cajón (13).

The slide (S) should be aligned with the underside of the drawer side (13).



Vídeo: Dicas para fixar o Minifix

Video: Consejos para arreglar Minifix

Video: Tips for Fixing Minifix

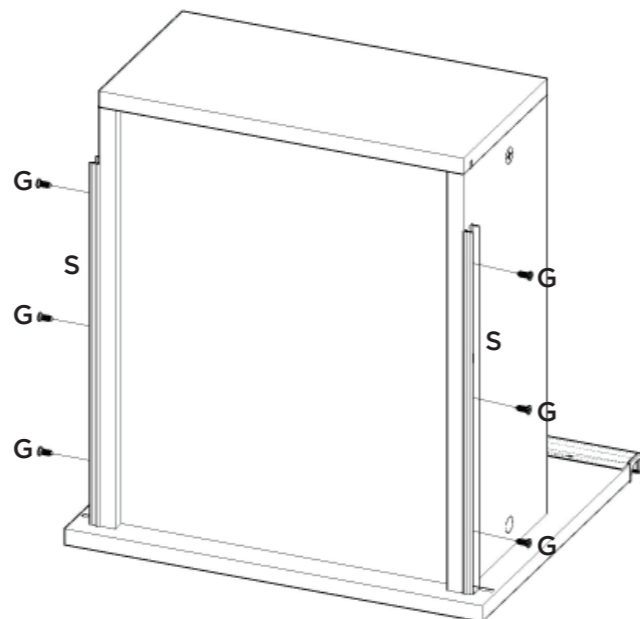

Esse tampo é opcional e é vendido separadamente (C905-33 e C905-170).

Esta vez es opcional y se vende por separado (C905-33 y C905-170).

This top is optional and is sold separately (C905-33 and C905-170).

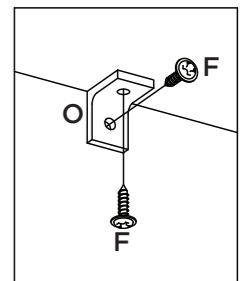
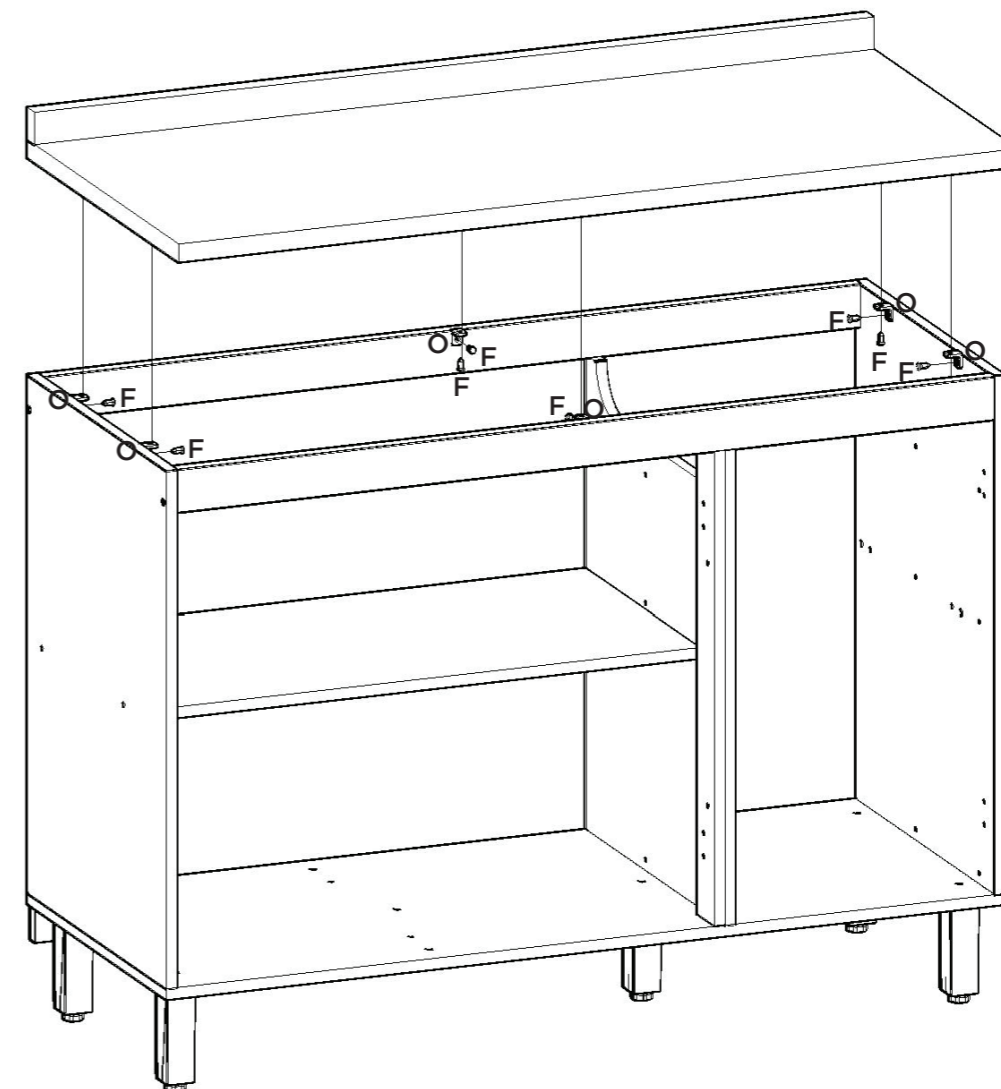
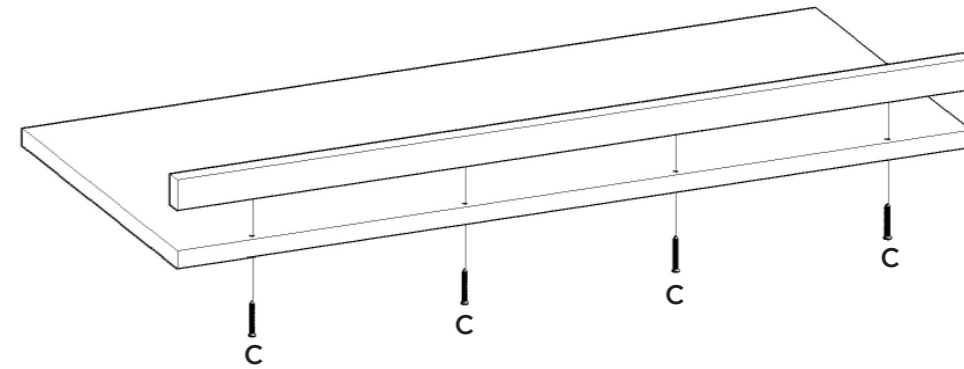

Caso o móvel seja montado com a opção do tampo, fixar o mesmo com 06 cantoneiras (O) e os parafusos 3,5x14mm (F).

Si se monta el auricular con la opción de la cubierta, fijarlo con Los ángulos 06 (O) y 3,5 x14mm tornillos (F).

If the furniture is to be installed with the top cover option, fix it with 06 (O) and 3.5x14mm screws (F).

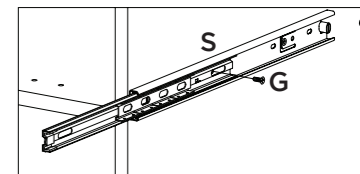
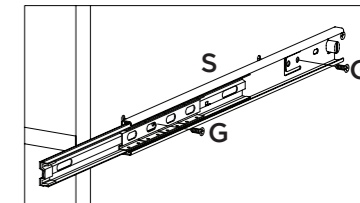
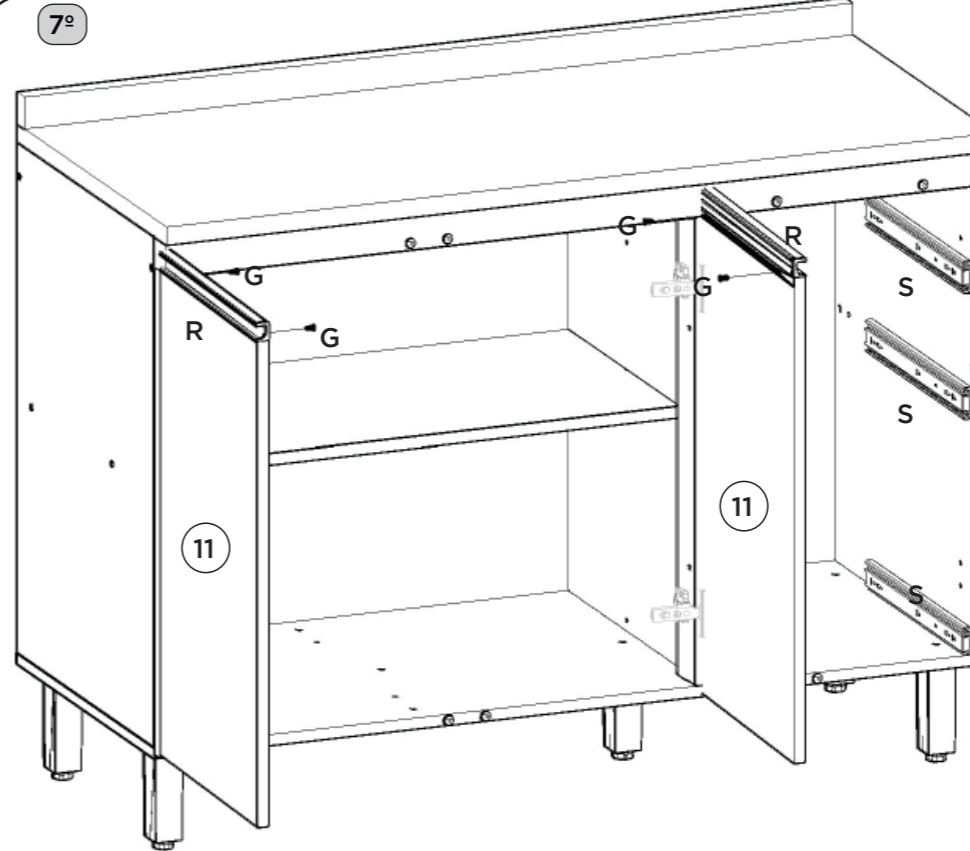
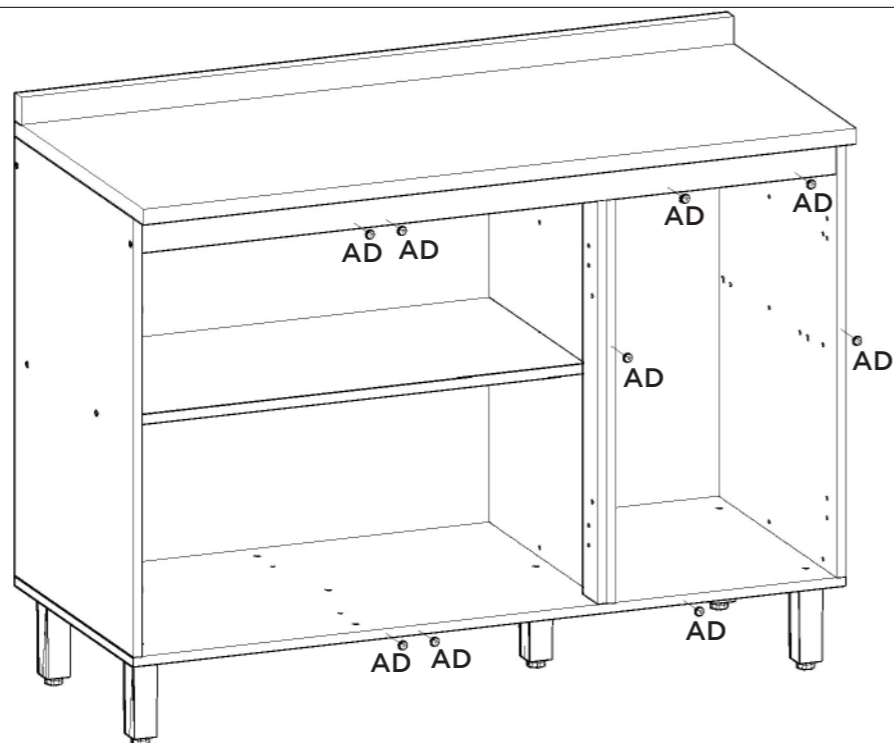
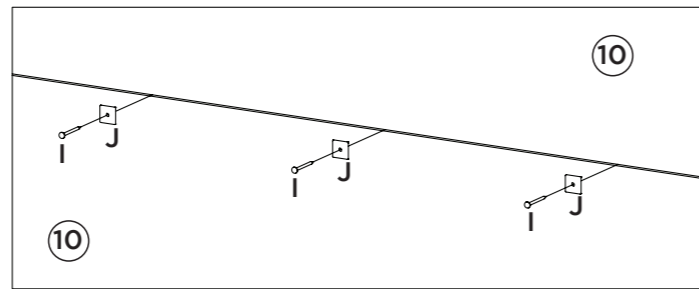
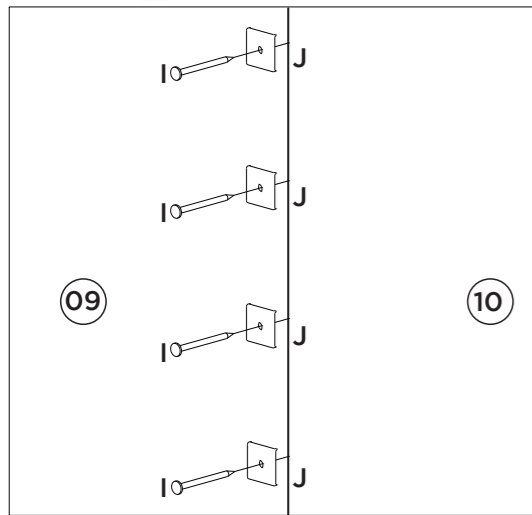
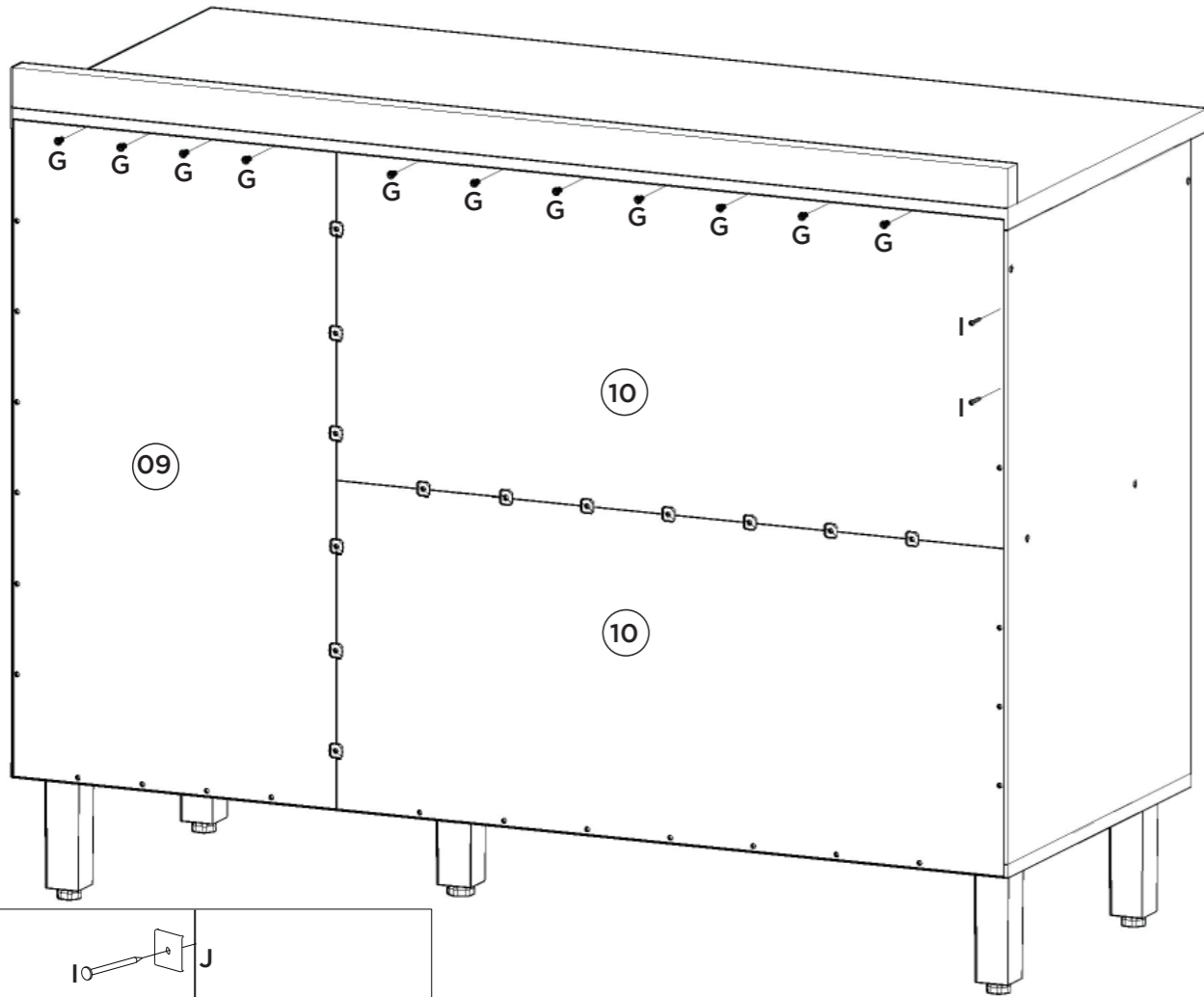

Vídeo: Dicas para fixar a Corrediça

Vídeo: Consejos para arreglar la diapositiva

Vídeo: Tips for Fixing the Slide

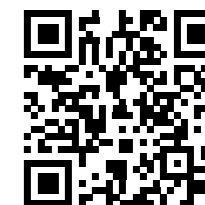

Vídeo: Instalar e regular Dobradiças

Vídeo: Instale y ajuste las bisagras

Vídeo: Install and adjust hinges

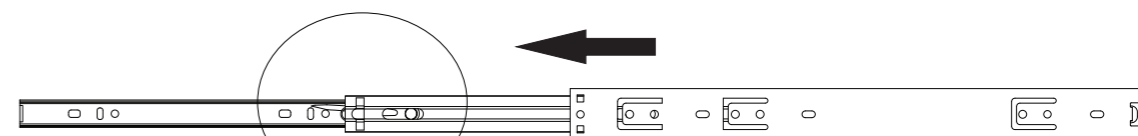
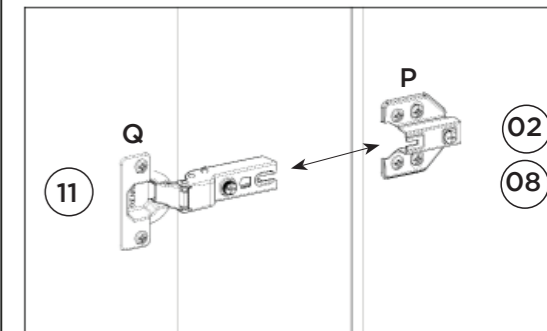
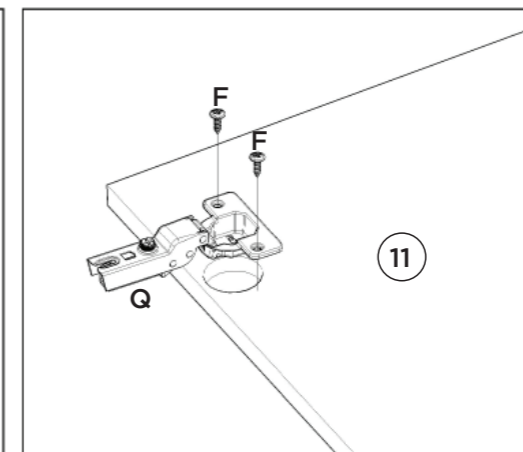
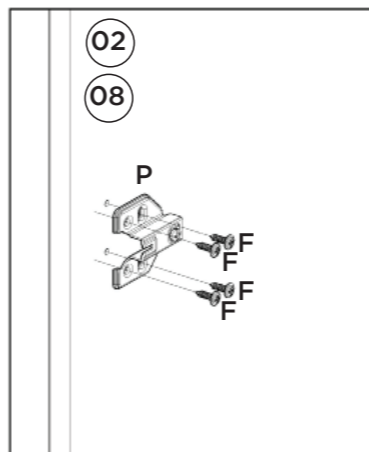

Para a desmontagem da corrediça siga a instrução ao lado.

Para el desmontaje seguimiento de diapositivas la instrucción siguiente a.

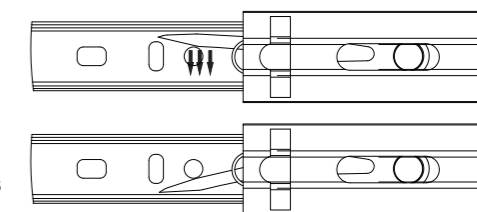

Fixar as corrediças nessas furações

Fijar las diapositivas de estos agujeros