

Produto Concluído  
Producto terminado  
Finished Product

ITM/1124-  
Rev 000



**HENN**

Ind. e Com. de Móveis Henn  
Mondai - SC - Brasil

+55 49 3674.3500

@moveishenn  
www.henn.com.br

ITM/1124-  
**INSTRUÇÕES DE  
MONTAGEM**

INSTRUCCIONES DE MONTAJE  
ASSEMBLY INSTRUCTIONS

## Roupeiro Alegria 4 Portas | Armario Alegria 4 Puertas | Wardrobe Alegria 4 Doors

I124-05 Branco HP  
I124-168 Rosa Chá



Requisitos para montagem  
Requisitos para la montaje  
Assembly Requirements

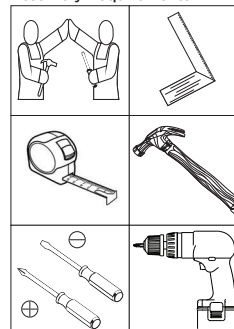

Imagens meramente ilustrativas,  
não acompanha o produto.  
Imágenes ilustrativas, no incluidas  
con el producto.  
Illustrative images, not included  
with the product.

### ASSISTÊNCIA TÉCNICA

Para solicitação de Assistência Técnica você consumidor deverá entrar em contato com o Lojista o qual você realizou a compra deste produto e solicitar a assistência técnica das peças avariadas. A garantia abrange todas as peças, partes e componentes que eventualmente venham apresentar defeito de fabricação no prazo de 03 (três) meses, contando a partir da entrega do produto ao consumidor, mediante nota fiscal de compra.

### AVISO

Para limpeza de seu móvel, use uma flanela seca ou umedecida, e não utilize produtos químicos que possam danificar seu produto.

### SISTEMA DE MONTAGEM

O sistema de montagem dos produtos, funciona de acordo com a ordem crescente dos números indicados no desenho. Ex: 01, 02, 03, 04... até a conclusão da montagem.

### ADVERTENCIA

Para limpieza de su móvil, use una flanela seca o húmeda, y no utilice productos químicos que puedan dañar su producto.

### SISTEMA DE MONTAJE

El sistema de montaje de los productos funciona de acuerdo con el orden creciente de los números indicados en el dibujo. Ej.: 01, 02, 03, 04... hasta la conclusión del montaje.

### NOTICE

To clean your furniture, use a dry or wet cloth, and do not use chemicals that may damage your product.

### ASSEMBLY SYSTEM

The products' assembly system works according to the increasing order of the indicated numbers. For example: 01, 02, 03, 04 ... to the end of the assembly.



PEÇAS REQUERIDAS

ACESSÓRIOS REQUERIDOS

FERRAMENTAS NECESSÁRIAS

24	RIPA DE TRÁS	x2
----	--------------	----

B		04
D		04
E		12
H		04
L		04
O		02
R		02
U		

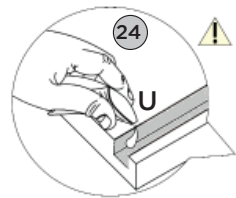
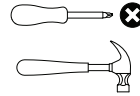

2x  
3º

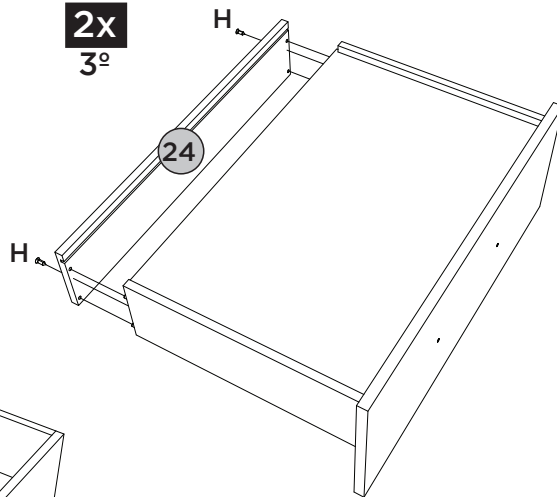

2x  
4º

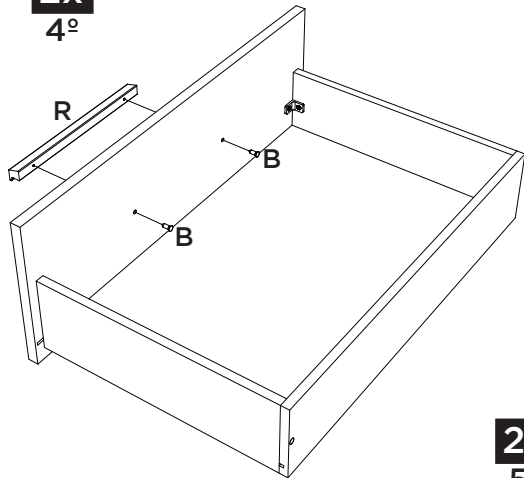

2x  
5º

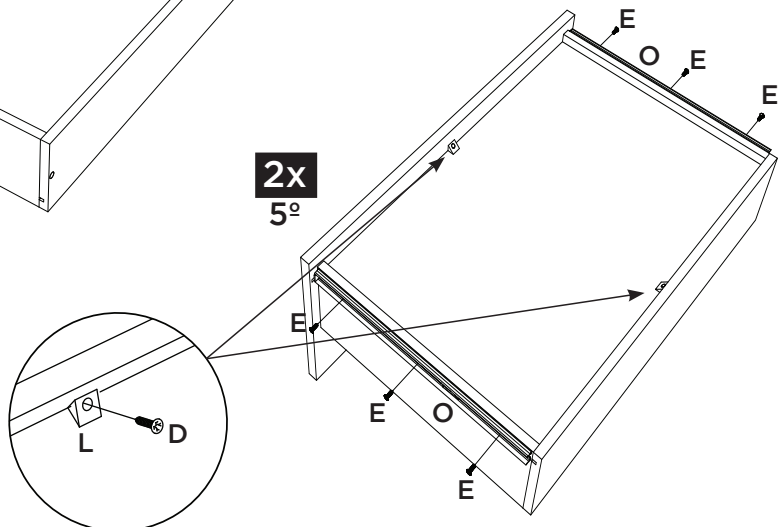

ACESSÓRIOS | ACCESORIOS | ACCESSORIES

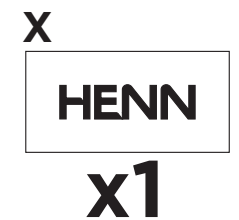
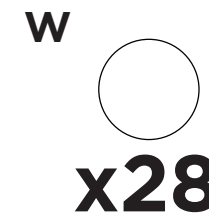
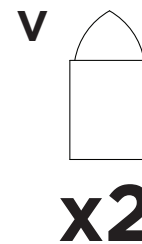
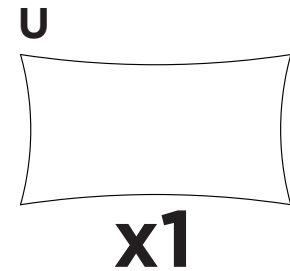
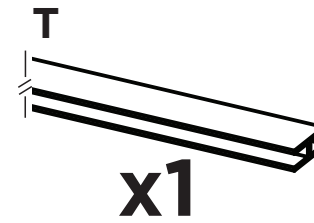
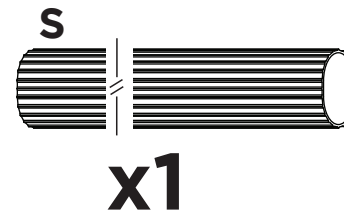
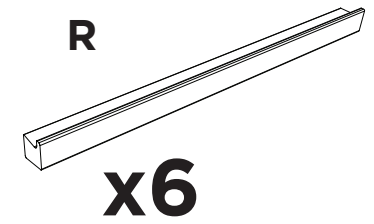
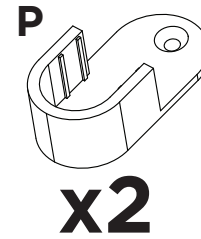
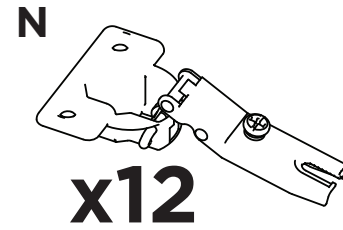

# LISTA DE PEÇAS | LISTA DE PIEZAS | LIST OF PIECES





Item	Caixa Caja Box	Qty Ctd Qty	Descrição Descripción Description	Dimensões (mm)   Dimensiones (mm)   Dimensions (mm)		
				Comprimento Largo Length	Largura Ancho Width	Espessura Grosor Thickness
1	2/2	01	RODAPÉ FRONTAL   ZÓCALO DELANTERO   FRONT PLINTH	1108	45	15
2	2/2	01	RODAPÉ TRASEIRO   ZÓCALO TRASERO   ZÓCALO TRASERO	1108	45	15
3	2/2	02	RODAPÉ LATERAL   ZÓCALO LATERAL   SIDE SKIRTING	285	45	15
4	1/2	04	PÉ MADEIRA PINUS   PÉ MADEIRA PINUS   PÉ WOOD PINUS	110	45	45
5	1/2	02	PÉ MADEIRA PINUS CRU   PIE DE MADERA DE PINO   RAW PINE WOOD FOOT	110	45	45
6	1/2	01	BASE   BASE   BASE	1202	380	15
7	2/2	01	LATERAL ESQUERDA   LADO IZQUIERDO   LEFT SIDE	1830	380	12
8=14	2/2	03	PRATELEIRA   ESTANTE   SHELF	285	320	12
9	1/2	01	DIVISÃO ESQUERDA   DIVISIÓN IZQUIERDA   DIVISÃO ESQUERDA	1468	380	12
10	2/2	01	TAMPO DAS GAVETAS   TAPA DE LOS CAJONES   TOP OF DRAWERS	584	380	12
11	1/2	01	DIVISÃO DIREITA   DIVISIÓN DERECHA   RIGHT DIVISION	1468	380	12
12	1/2	02	RIPA DO MALEIRO   TRAVESAÑO SUPERIOR   MALEIRO'S LATH	350	73	12
13	1/2	01	CHÃO DO MALEIRO   REPISA SUPERIOR   FLOOR OF MALEIRO	1178	380	12
14=8	2/2	03	PRATELEIRA   ESTANTE   SHELF	285	320	12
15	2/2	01	LATERAL DIREITA   LADO DERECHO   RIGHT SIDE	1830	380	12
16	2/2	01	TAMPO   TAPA   TOP	1204	406	15
17	1/2	01	FUNDO SUPERIOR   ARRIBA ABAJO   TOP BOTTOM	1196	370	3
18	2/2	04	FUNDO   FONDO   BOTTOM	1489	298	3
19	1/2	02	PORTA MENOR   PUERTA MÁS PEQUEÑA   SMALLER DOOR	1385	295	15
20	2/2	02	PORTA   PUERTA   DOOR	1833	295	15
21	1/2	02	FRENTE DE GAVETA   FRENTE DEL CAJÓN   DRAWER FRONT	594	220	15
22	2/2	04	LADO DE GAVETA   LATERAL DEL CAJÓN   DRAWER SIDE	350	110	12
23	2/2	02	FUNDO DE GAVETA   FONDO DEL CAJÓN   DRAWER BOTTOM	551	361	3
24	2/2	02	RIPA DE TRÁS   TRAVESAÑO TRASERO   REAR CLAPBOARD	564	110	12

## PASSO 12

### PEÇAS REQUERIDAS

21	FRENTE DE GAVETA	x2
22	LADO DE GAVETA	x4
23	FUNDO DE GAVETA	x2

### ACESSÓRIOS REQUERIDOS

E		08
G		16
K		04
U		

### FERRAMENTAS NECESSÁRIAS

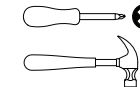

4x

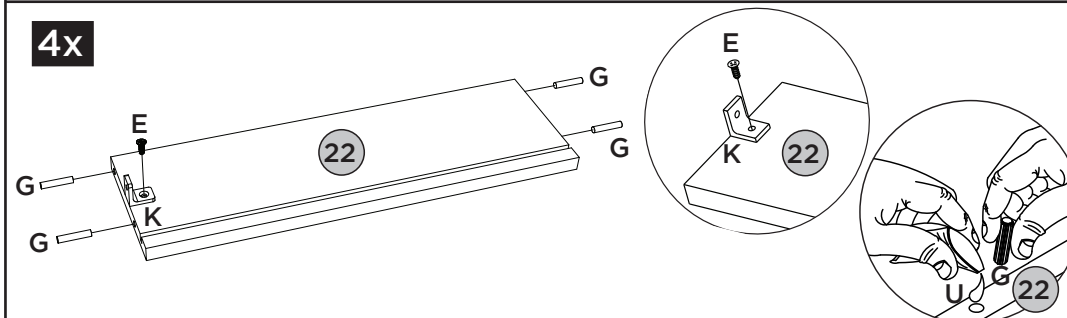

2x

1º

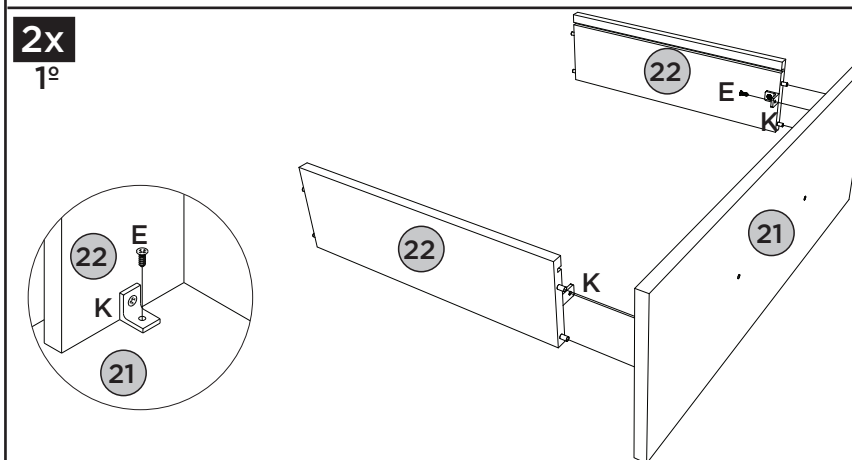

2x

2º

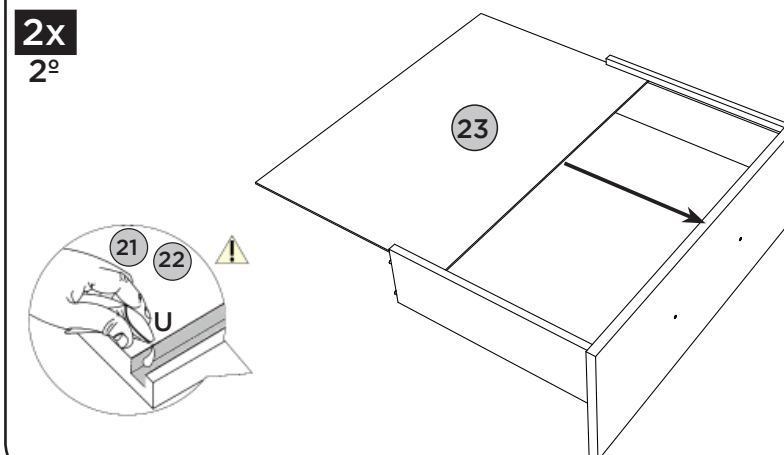

# PASSO 11

ITM/I124-

## PEÇAS REQUERIDAS

19	PORTA MENOR	x2
20	PORTA	x2

## ACESSÓRIOS REQUERIDOS

B		08
C		24
N		12
R		04
S		01

## FERRAMENTAS NECESSÁRIAS

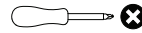

ou:



Usar Torque 15

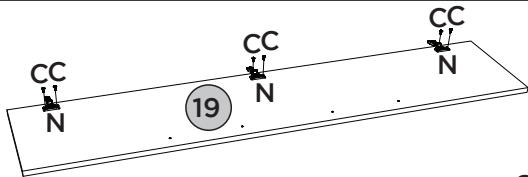

Fazer furação passante para puxador (R) na porta menor (19).

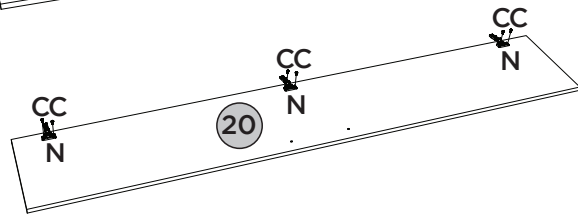

Perfore orifícios para la manija (R) en la puerta más pequeña (19).

Drill through holes for handle (R) in the smaller door (19).

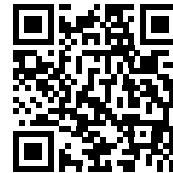

Vídeo: Instalar e regular Dobradiças

Video: Instale y ajuste las bisagras

Video: Install and adjust hinges

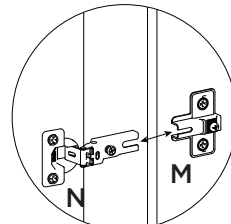
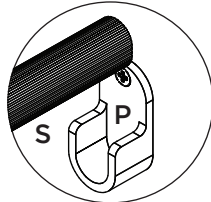
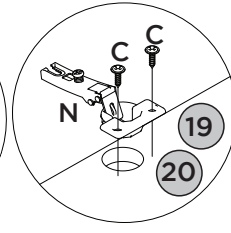
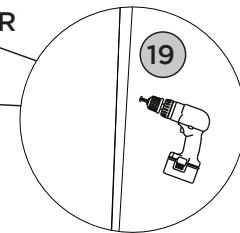
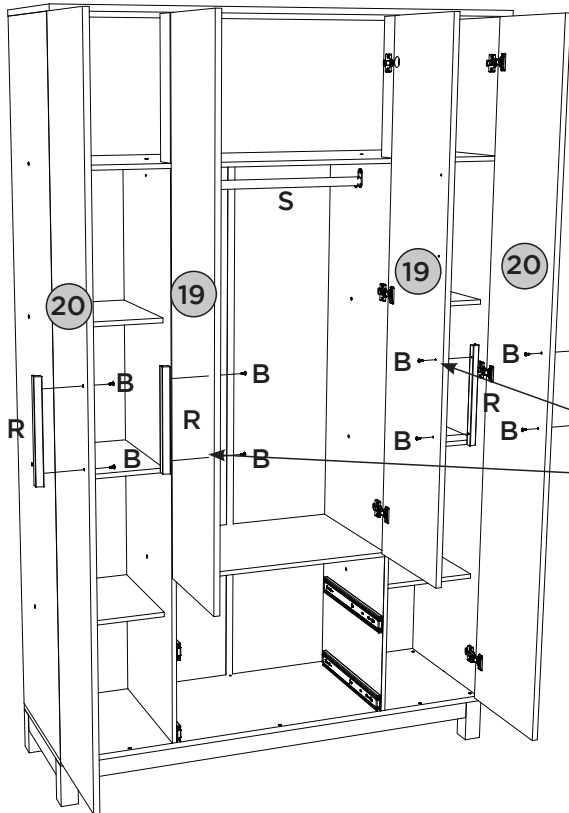

# LISTA DE PEÇAS | LISTA DE PIEZAS | LIST OF PIECES

ITM/I124-

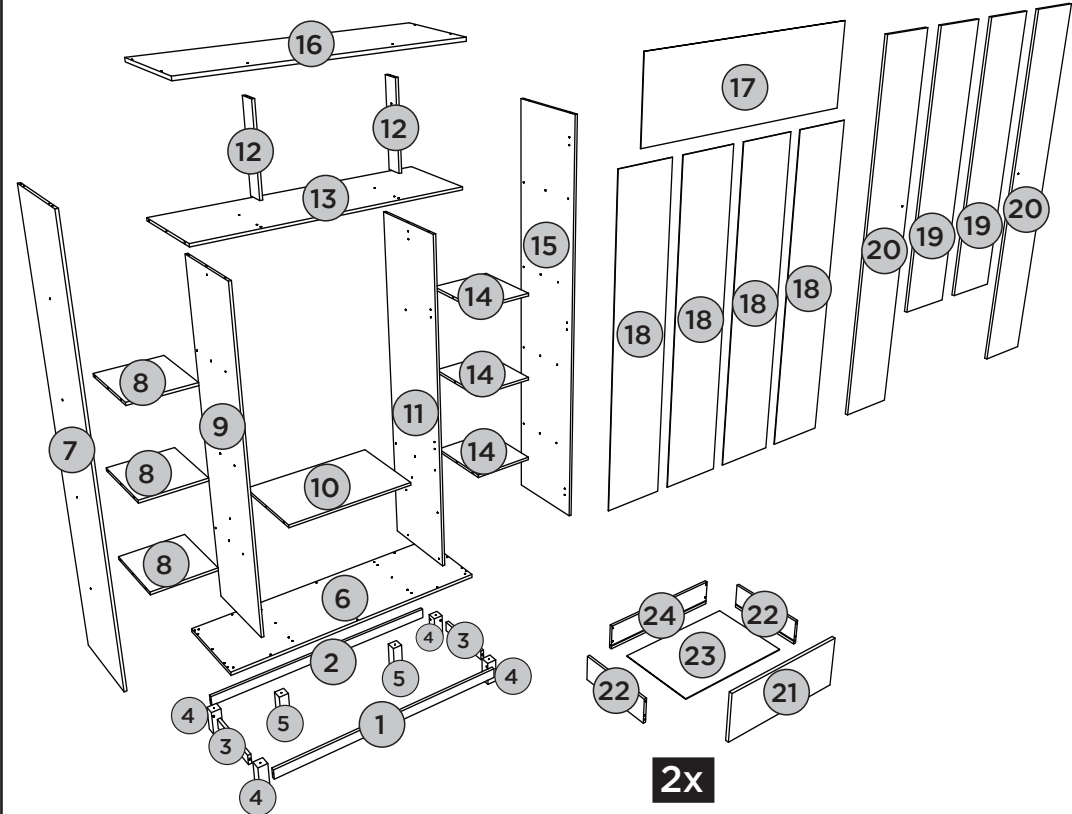

# PASSO 1

ITM/1124-

## PEÇAS REQUERIDAS

1	RODAPÉ FRONTAL	x1
2	RODAPÉ TRASEIRO	x1
3	RODAPÉ LATERAL	x2

## ACESSÓRIOS REQUERIDOS

F		08
---	---	----

## FERRAMENTAS NECESSÁRIAS

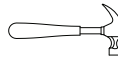



# PASSO 10

ITM/1124-

## PEÇAS REQUERIDAS

17	FUNDO SUPERIOR	x1
18	FUNDO	x4

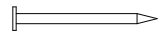
## ACESSÓRIOS REQUERIDOS

I		106
J		30
T		01

## FERRAMENTAS NECESSÁRIAS

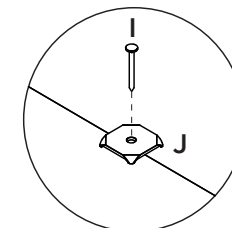
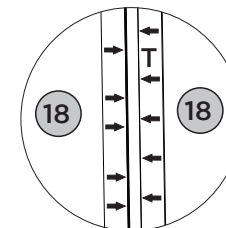
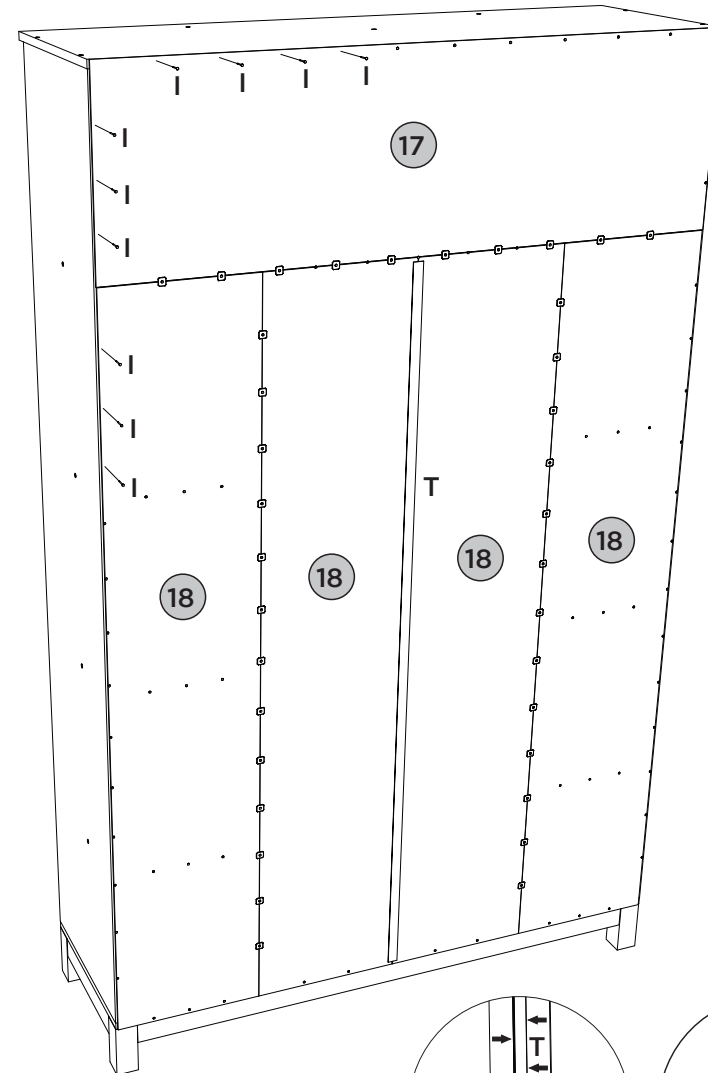
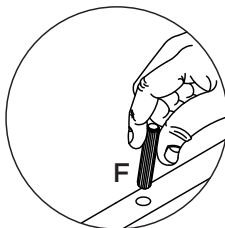
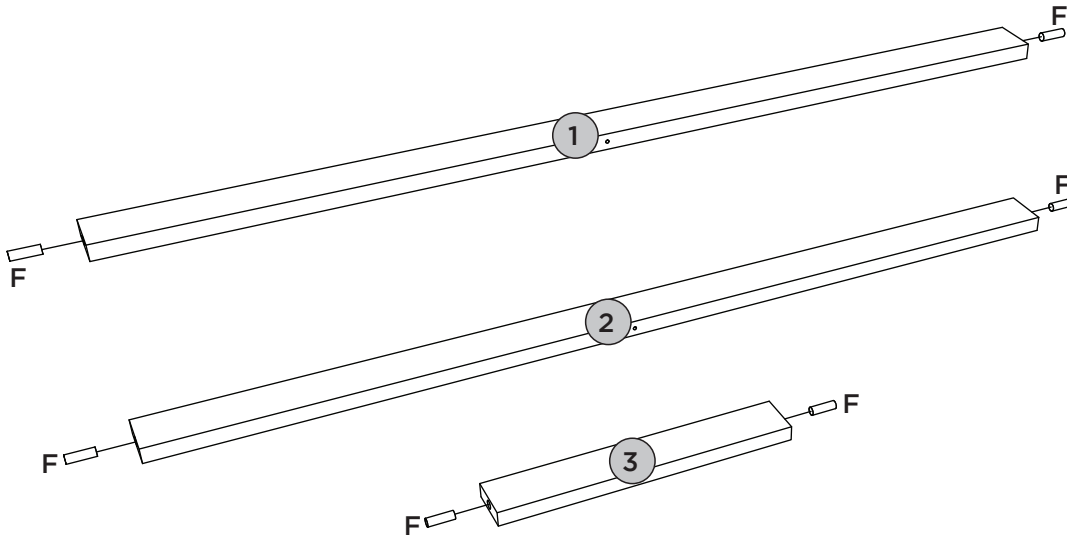

ACESSÓRIOS REQUERIDOS

A		10
C		04
K		02

FERRAMENTAS NECESSÁRIAS

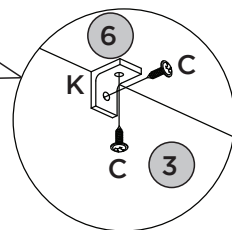
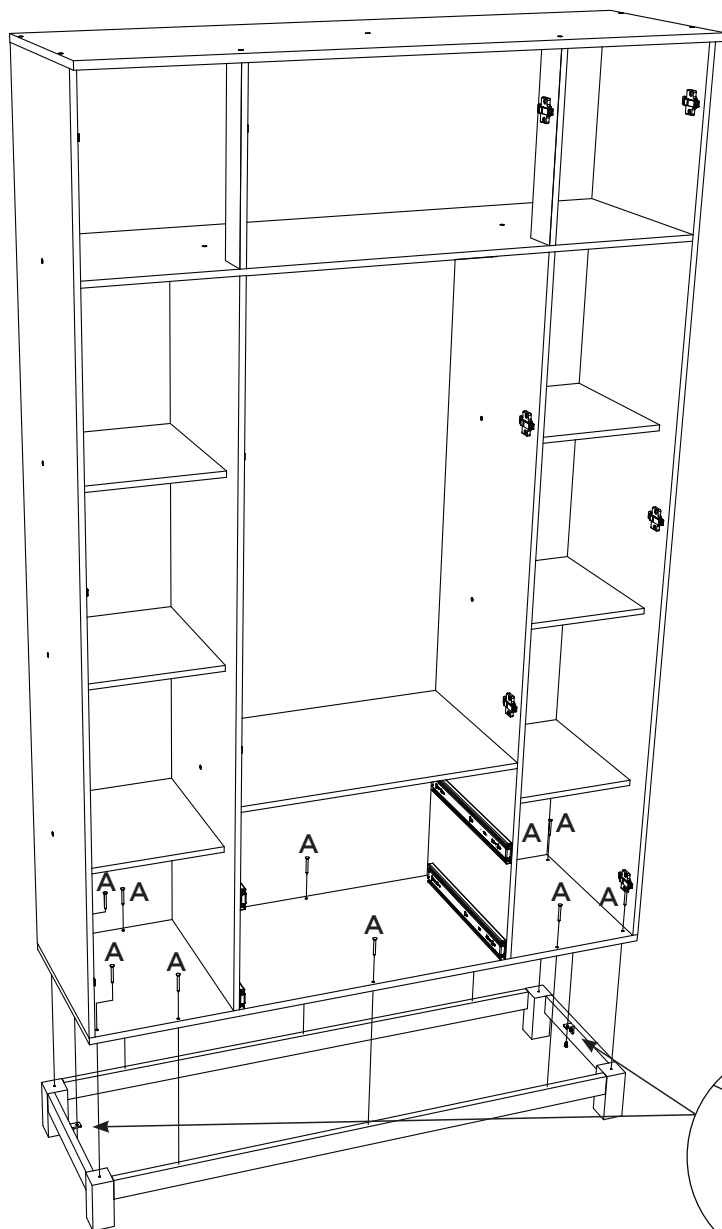
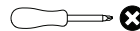

PEÇAS REQUERIDAS

7	LATERAL ESQUERDA	x1
8=14	PRATELEIRA	x6
9	DIVISÃO ESQUERDA	x1

ACESSÓRIOS REQUERIDOS

C		10
E		08
G		32
M		05
O		02
P		01

FERRAMENTAS NECESSÁRIAS

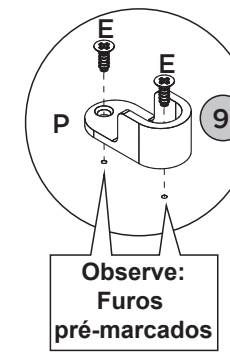
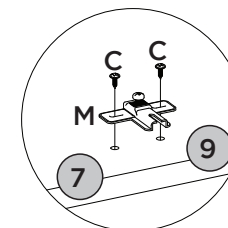
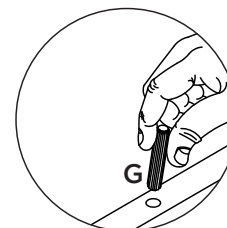
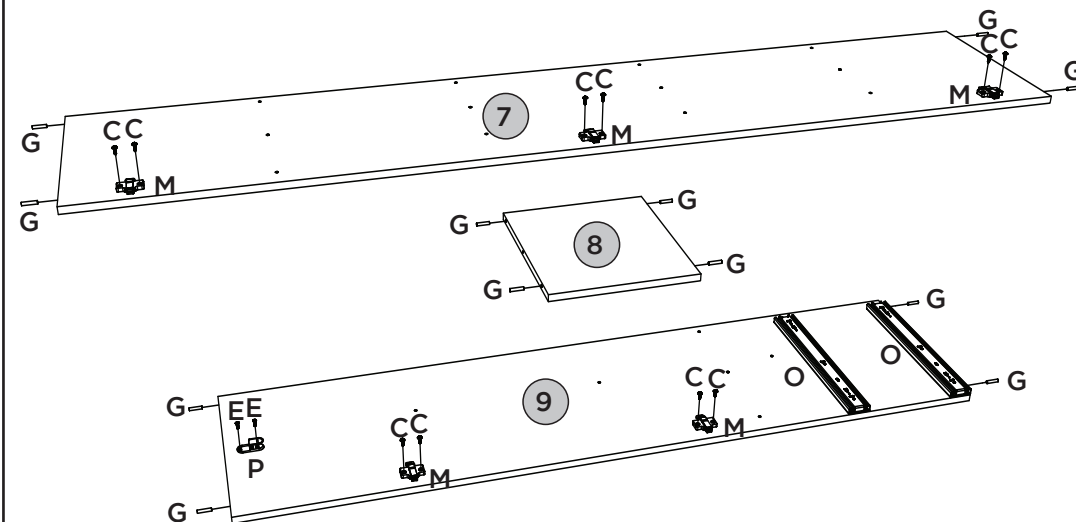
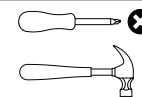

Observe:  
Furos  
pré-marcados

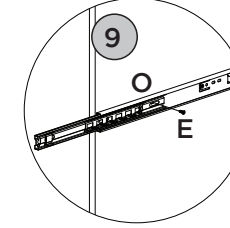
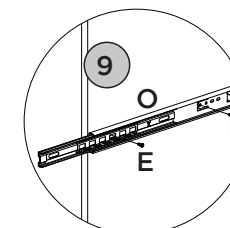

### PASSO 3

ITM/1124-

#### PEÇAS REQUERIDAS

10	TAMPO DAS GAVETAS	x1
11	DIVISÃO DIREITA	x1

#### ACESSÓRIOS REQUERIDOS

C		04
E		08
G		08
M		02
O		02
P		01

#### FERRAMENTAS NECESSÁRIAS

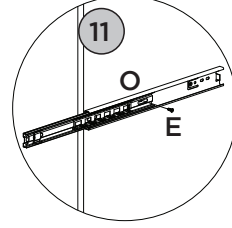
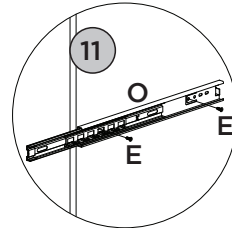
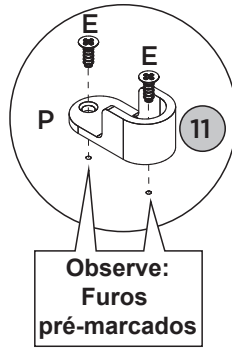
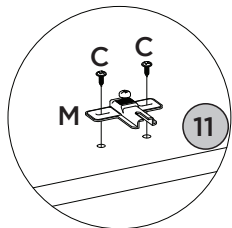
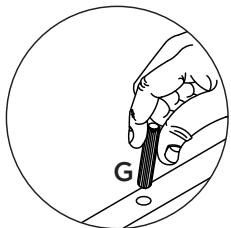
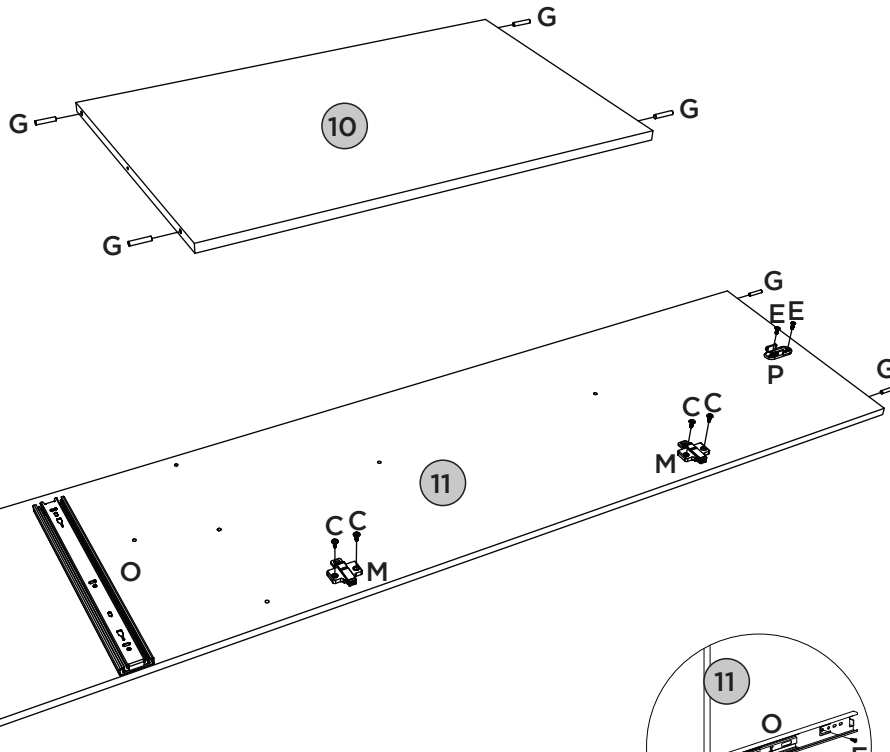
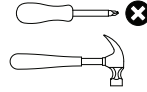

### PASSO 8

ITM/1124-

#### PEÇAS REQUERIDAS

14=8	PRATELEIRA	x3
15	LATERAL DIREITA	x1
16	TAMPO	x1

#### ACESSÓRIOS REQUERIDOS

A		15
---	--	----

#### FERRAMENTAS NECESSÁRIAS

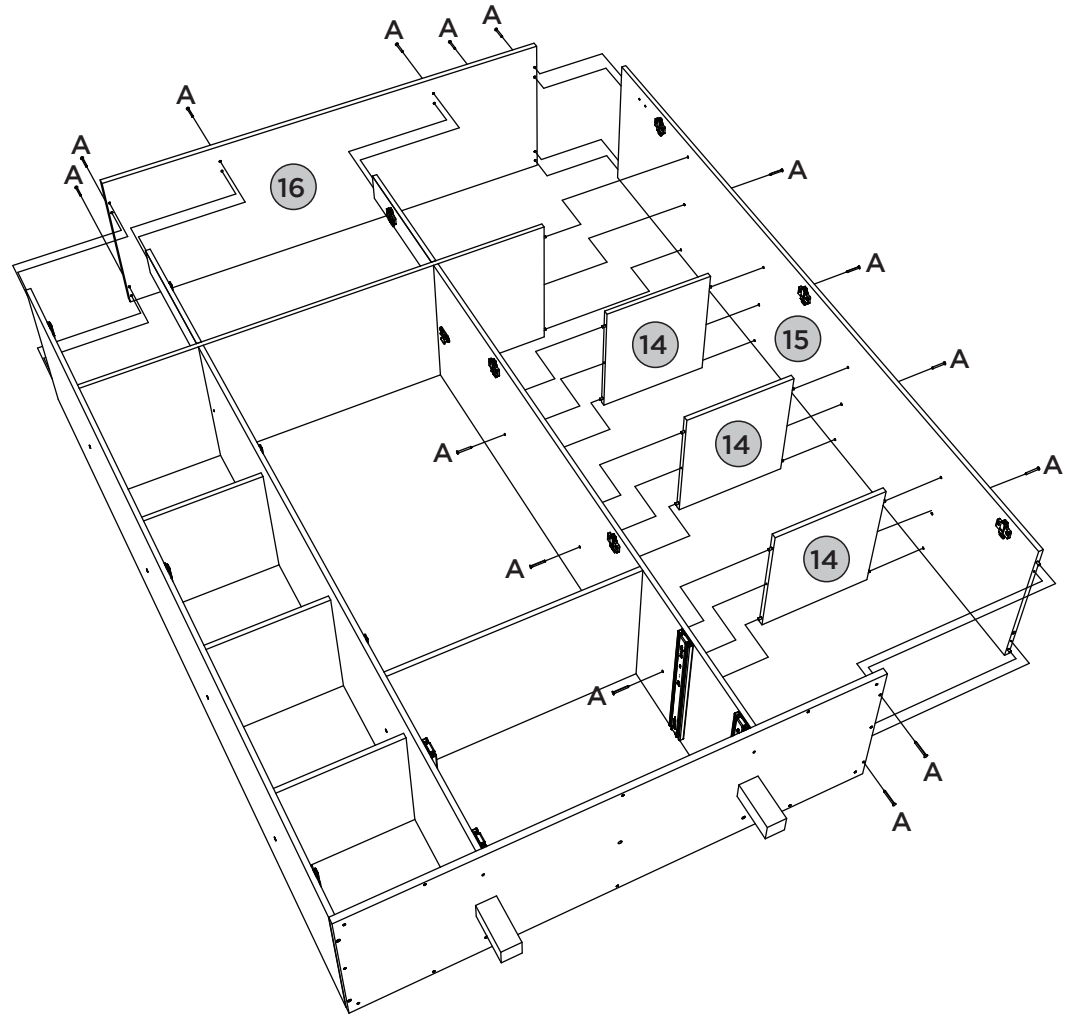
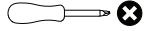

# PASSO 7

ITM/1124-

## PEÇAS REQUERIDAS

10	TAMPO DAS GAVETAS	x1
11	DIVISÃO DIREITA	x1
12	RIPA DO MALEIRO	x2
13	CHÃO DO MALEIRO	x1

## ACESSÓRIOS REQUERIDOS

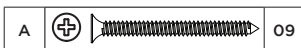

## FERRAMENTAS NECESSÁRIAS

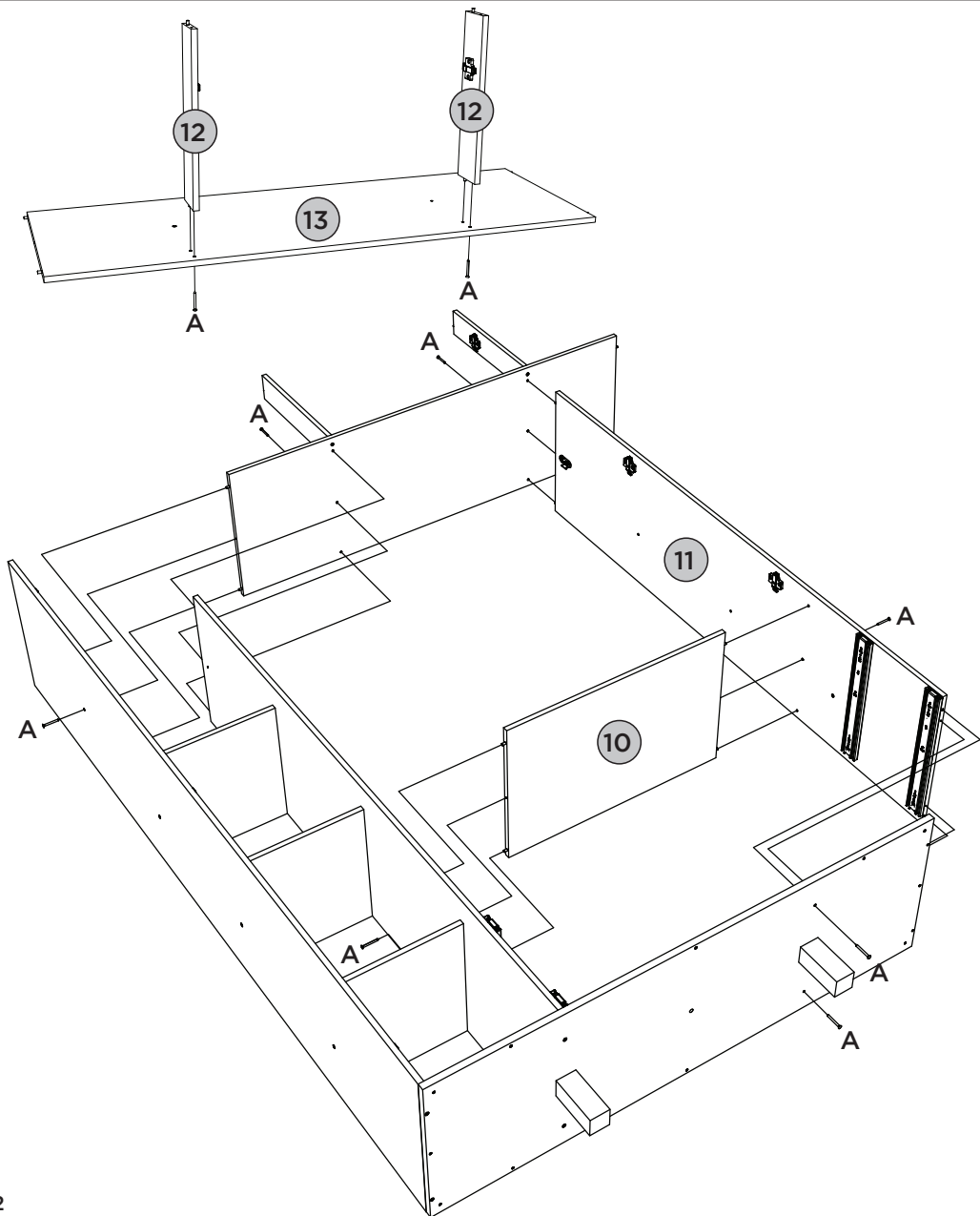
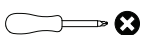

# PASSO 4

ITM/1124-

## PEÇAS REQUERIDAS

12	RIPA DO MALEIRO	x2
13	CHÃO DO MALEIRO	x1
15	LATERAL DIREITA	x1

## ACESSÓRIOS REQUERIDOS

C		10
G		12
M		05

## FERRAMENTAS NECESSÁRIAS

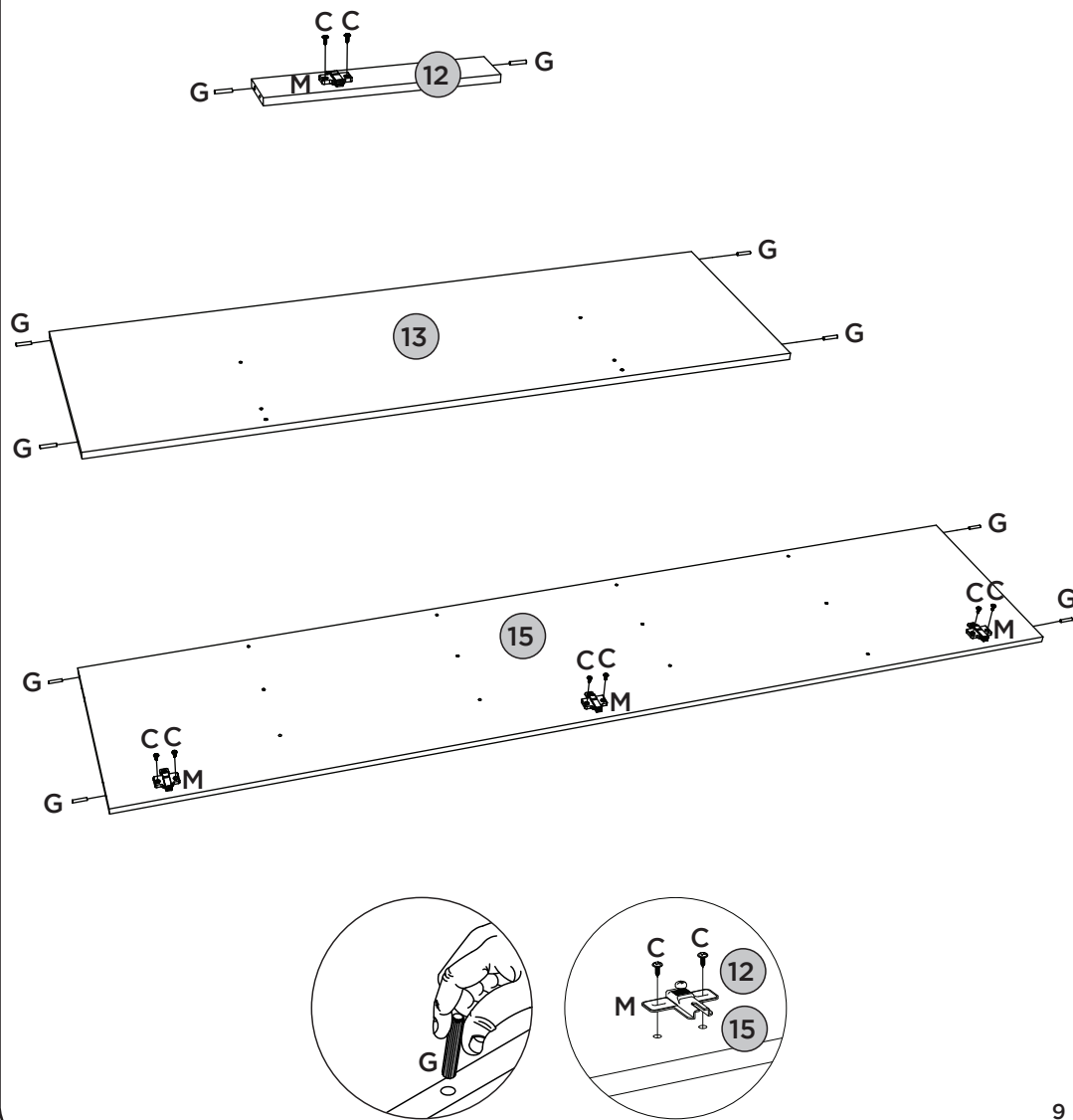
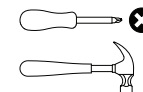



## PASSO 5

ITM/1124-

### PEÇAS REQUERIDAS

1	RODAPÉ FRONTAL	x1
2	RODAPÉ TRASEIRO	x1
3	RODAPÉ LATERAL	x2
4	PÉ MADEIRA PINUS	x4

### ACESSÓRIOS REQUERIDOS

C		16
Q		08

### FERRAMENTAS NECESSÁRIAS

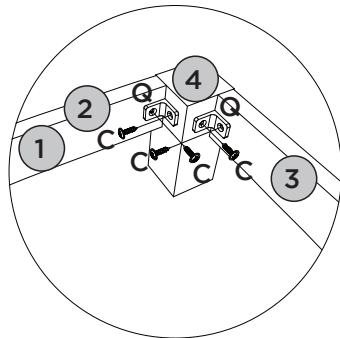
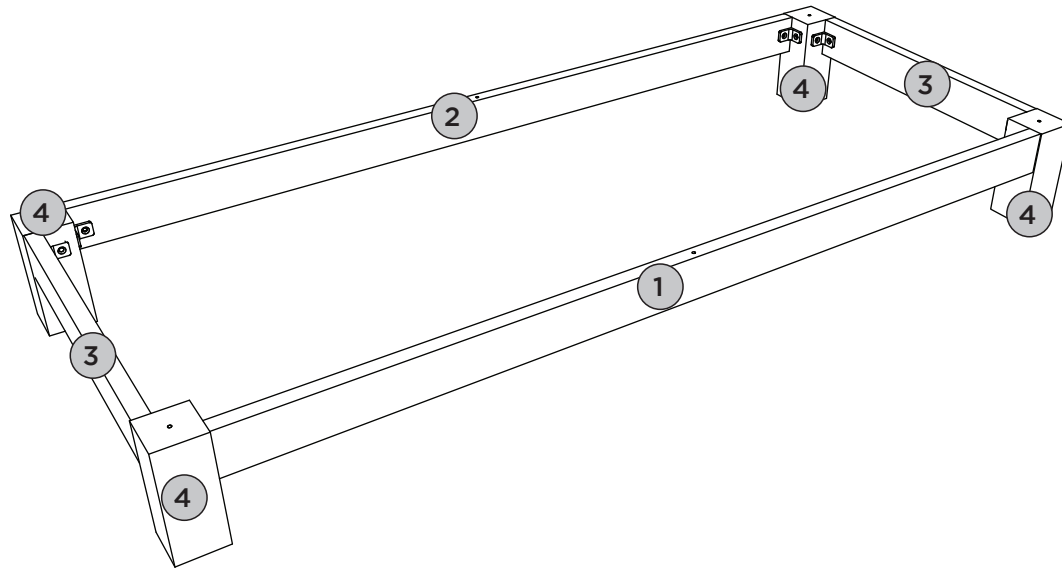
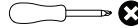

## PASSO 6

ITM/1124-

### PEÇAS REQUERIDAS

5	PÉ MADEIRA PINUS CRU	x2
6	BASE	x1
7	LATERAL ESQUERDA	x1
8	PRATELEIRA	x3
9	DIVISÃO ESQUERDA	x1

### ACESSÓRIOS REQUERIDOS

A		12
---	---	----

### FERRAMENTAS NECESSÁRIAS

