

INSTRUÇÕES DE MONTAGEM

INSTRUCCIONES DE MONTAJE
ASSEMBLY INSTRUCTIONS

Canto Oblíquo Seletto 01 Porta

MC07-133 Areia HP

MC07-184 Areia HP/Jequitibá

Opção 1
Opción 1
Option 1

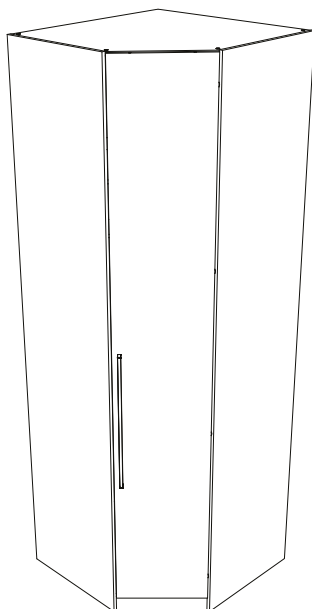

Opção 2
Opción 2
Option 2

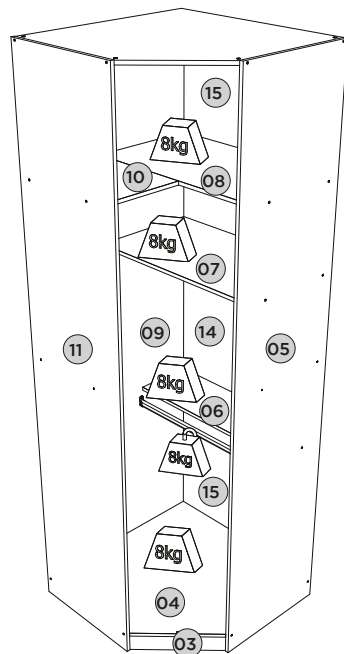
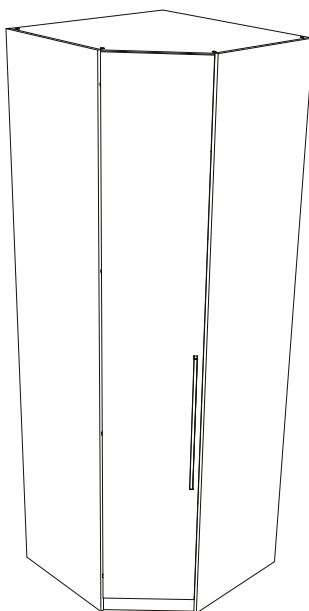

Requisitos para montagem
Requisitor para la montaje
Assembly Requirements

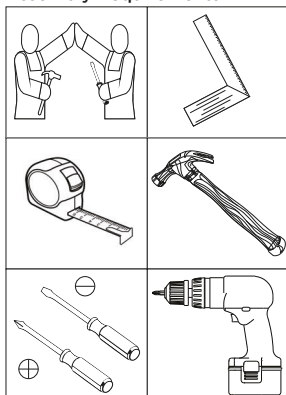

Pesos máximos recomendados com carga distribuída
Peso máximo recomendado con la carga distribuida
Recommended maximum weights with evenly distributed.

AVISO

Para limpeza de seu móvel, use uma flanela seca ou umedecida, e não utilize produtos químicos que possam danificar seu produto.

SISTEMA DE MONTAGEM

O sistema de montagem dos produtos, funciona de acordo com a ordem crescente dos números indicados no desenho. Ex: 01, 02, 03, 04... até a conclusão da montagem.

ADVERTENCIA

Para limpieza de su móbil, use una franela seca o húmeda, y no utilice productos químicos que puedan dañar su producto.

SISTEMA DE MONTAJE

El sistema de montaje de los productos funciona de acuerdo con el orden creciente de los números indicados en el dibujo. Ej.: 01, 02, 03, 04... hasta la conclusión del montaje.

NOTICE

To clean your furniture, use a dry or wet cloth, and do not use chemicals that may damage your product.

ASSEMBLY SYSTEM

The products' assembly system works according to the increasing order of the indicated numbers. For example: 01, 02, 03, 04 ... to the end of the assembly.

Imagens meramente ilustrativas
Imágenes meramente ilustrativas
Images for illustration only

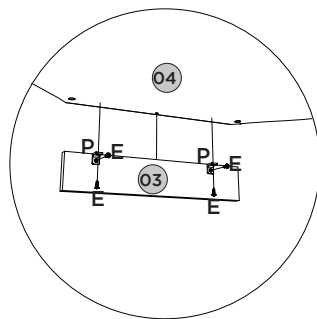
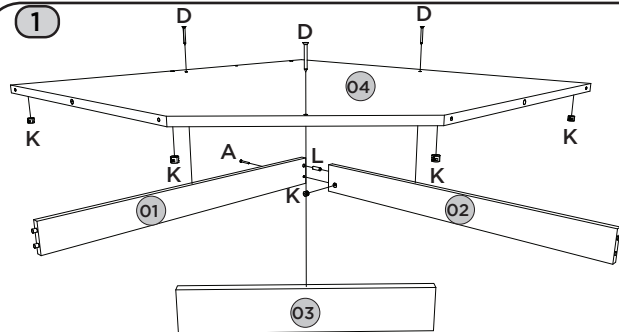

ATENÇÃO: Quando o Canto Obliquo for acoplado à Mesa de Cabeceira, a porta do Canto deverá abrir no sentido do Mesa de Cabeceira.

ATENCIÓN: Cuando la Esquina Inclinada se une a la Mesita de Noche, la puerta de la Esquina debe abrirse hacia la Mesita de Noche.

ATTENTION: When the Slanted Corner is attached to the Bedside Table, the Corner door must open towards the Bedside Table.

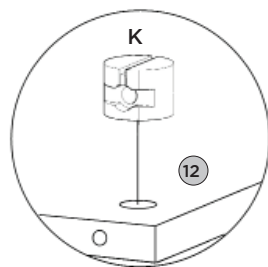
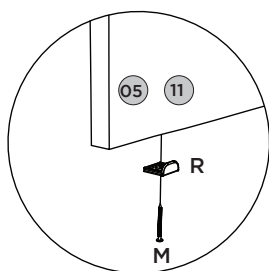
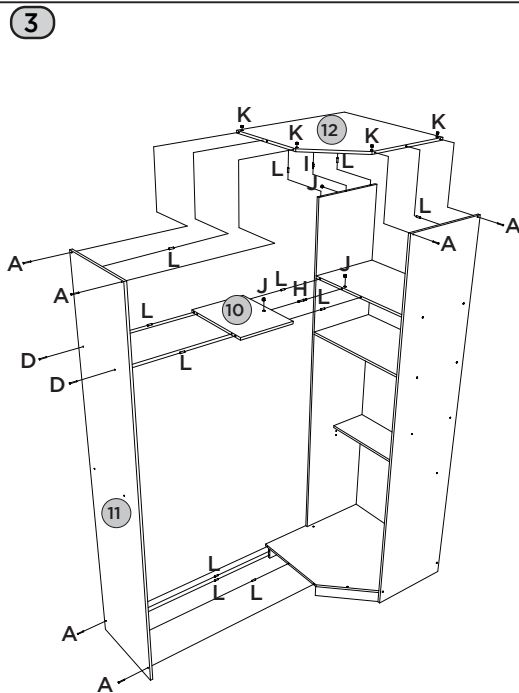
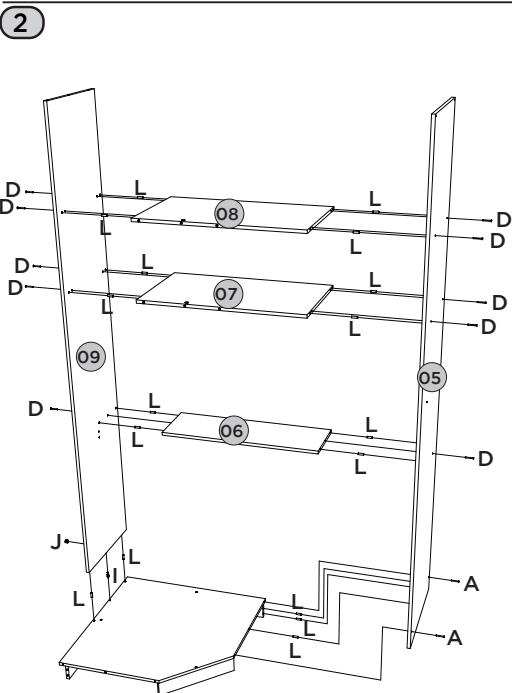
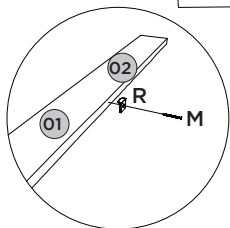

4

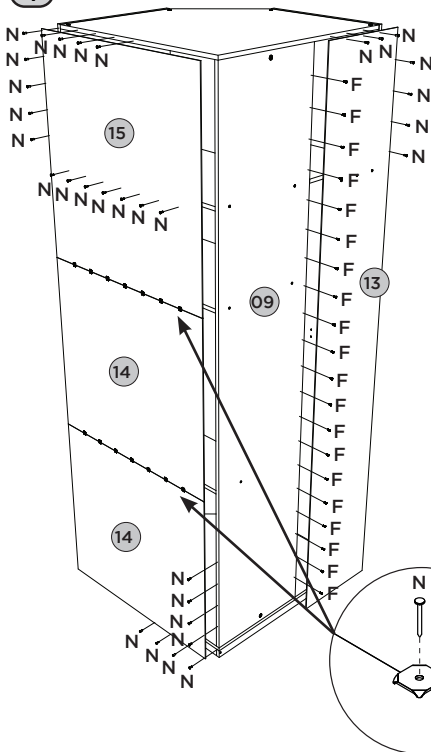

5

Portas vendidas separadamente
M253-133 Areia HP
M253-178 Jequitibá

Las puertas se venden por separado
M253-133 Areia HP
M253-178 Jequitibá

Doors sold separately
M253-133 Areia HP
M253-178 Jequitibá

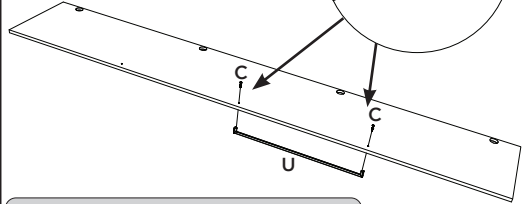

Fazer furação passante para fixar os puxadores, utilizando as pré marcações existentes nas portas.

Taladre agujeros para fijar las manijas, utilizando las marcas previas en las puertas.

Drill through holes to fix the handles, using the pre-markings on the doors.

6

Fazer furação passante para fixar o puxador, utilizando as pré marcações existentes nas portas.





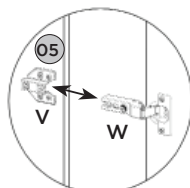
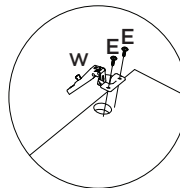
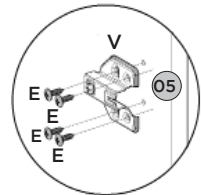
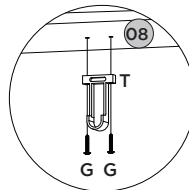
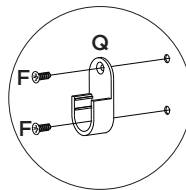
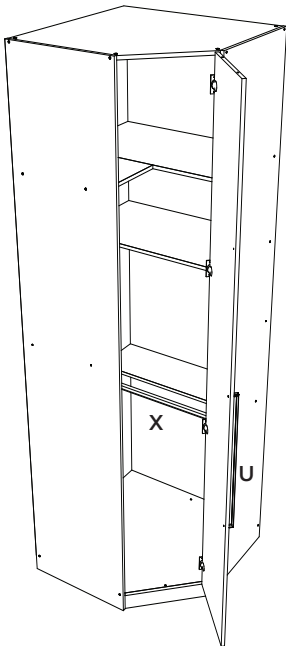





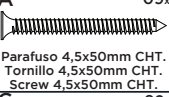

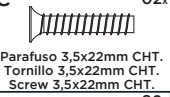



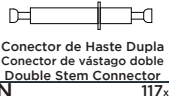





Taladre agujeros para fijar la manija, utilizando las marcas previas en las puertas.

Drill through holes to fix the handle, using the pre-markings on the doors.

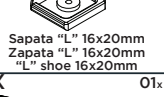
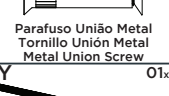
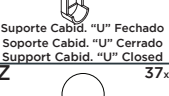

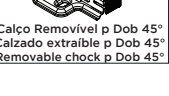
Item	Caixa Caja Box	Qtd Ctd Qty	Descrição Descripción Description	Medidas (mm) Dimensions (mm) Size (measurements) (mm)
01	1/2	01	Rodapé Traseiro Maior Rodapié trasero mayor Larger Back Footer	764x73x15
02	1/2	01	Rodapé Traseiro Menor Rodapié trasero menor Rear Footer Minor	749x73x15
03	1/2	01	Rodapé Frontal Rodapié Frontal Front baseboard	395x73x15
04	1/2	01	Base Base Base	796x796x15
05	2/2	01	Lateral direita Lateral derecha Right side	2400x520x15
06	1/2	01	Prateleira do varão Estantería hombre Rod shelf	781x520x15
07	1/2	01	Prateleira Estante Shelf	781x450x15
08	1/2	01	Prateleira fixa Estante fija Fixed shelf	781x450x15
09	2/2	01	Fundo 15mm Fondo 15mm 15mm Bottom	2296x450x15
10	1/2	01	Prateleira Menor Estante menor Minor shelf	331x450x15
11	2/2	01	Lateral esquerda Lateral izquierda Left side	2400x520x15
12	1/2	01	Tampo Tapa Top	796x796x15
13	2/2	01	Fundo Fondo Bottom	2324x370x3
14	1/2	02	Fundo Inferior Fondo inferior bottom background	730x805x3
15	1/2	01	Fundo Superior Fondo superior Superior background	854x805x15

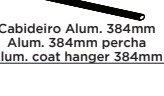
Ferragens | Herrajes | Hardware

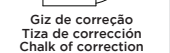
A  Parafuso 4,5x50mm CHT. Tornillo 4,5x50mm CHT. Screw 4,5x50mm CHT.	B  Etiqueta resinada Henn Etiqueta resinada Henn Henn resin label	C  Parafuso 3,5x22mm CHT. Tornillo 3,5x22mm CHT. Screw 3,5x22mm CHT.	D  Parafuso 3,5x40mm CHT. Tornillo 3,5x40mm CHT. Screw 3,5x40mm CHT.	E  Parafuso 3,5x14mm FLA. Tornillo 3,5x14mm FLA. Screw 3,5x14mm FLA.	F  Parafuso 3,5x12mm CHT. Tornillo 3,5x12mm CHT. Screw 3,5x12mm CHT.
G  Parafuso 3,0x20mm FLA. Tornillo 3,0x20mm FLA. Screw 3,0x20mm FLA.	H  Conector de haste dupla Conector de vástago doble Double Stem Connector	I  Parafuso minifix Tornillo minifix Minifix bolt	J  Tambor minifix Tambor minifix Minifix drum	K  Porca cilíndrica Tuerca cilíndrica Cylindrical nut	L  Cavilha 8x25mm Cinta 8x25mm Dowel 8x25mm
M  Prego 12x12mm Anelado Clavo 12x12mm Anilado Ringed Nails 12x12mm	N  Prego 10x10mm Clavo 10x10mm Nail 10x10mm	O  Fixador de fundos Fijador de fondos Bottom fixer	P  Cantoneira plástica Cantoneira plástica Plastic angle brackets	Q  Suporte cabideiro Soporte de percha Coat hanger support	R  Sapata "L" 16x20mm Zapata "L" 16x20mm "L" shoe 16x20mm
S  Parafuso União Metal Tornillo Unión Metal Metal Union Screw	T  Suporte Cabid. "U" Fechado Soporte Cabid. "U" Cerrado Supporte Cabid. "U" Closed	U  Puxador Aleno Fit Alumínio Mango de alumínio Aleno Fit Aleno Fit Aluminum Handle	V  Calço Removível p Dob 45° Calzado extraíble p Dob 45° Removable chock p Dob 45°	W  Dobradilha 45° Caneca 35mm com Amortecimento Bisagra 45° Taza 35mm con Amortiguación Hinge 45° Mug 35mm with Damping	X  Cabideiro Alum. 384mm Alum. 384mm percha Alum. coat hanger 384mm
Y  Cabideiro Alum. 773mm Alum. 773mm percha Alum. coat hanger 773mm	Z  Adesivo tapa parafuso 10mm Adhesivo tapón de tornillo 10mm Bolt cover adhesive 10mm	AA  Giz de correção Tiza de corrección Chalk of correction			

A união (S) deve ser usada somente quando este módulo for acoplado a outro módulo componível Henn, para unir duas peças de 15mm. Caso ele seja usado separadamente, a utilização do união não se faz necessário.

La unión (S) se debe utilizar sólo cuando el módulo está acoplado a otro módulo composable Henn, para unirse a dos 15mm piezas. Si se utiliza por separado, el uso de unión no es necesario.

The union (S) should be used only when this module is coupled to another Module Henn, to join two pieces of 15mm. If it is used separately, the use of the union is not necessary.

Agora que você já comprou o seu móvel, ele merece ser montado do jeito certo.

Erros de montagem causam mais de **60%** dos danos em móveis.

Por que contratar?

Tranquilidade do **início ao fim** da montagem



PROFISSIONAIS QUALIFICADOS

Especialistas certificados na **MadeiraMadeira Serviços**.



FERRAMENTAS PROFISSIONAIS

que **protegem** seus móveis.



AGENDAMENTO EM 24 HORAS

escolha a data e o turno **ideais para** você.



GARANTIA DE 3 MESES

de cobertura **completa**.

Mais de 1 MILHÃO DE MONTAGENS
★ com avaliação **4.7** ★

Mariana S., São Paulo

"Chegaram no horário e montaram tudo rapidamente. Serviço incrível!"



Carlos R., Belo Horizonte

"Tentei montar sozinho e foi um desastre. Com a **MadeiraMadeira Serviços** ficou perfeito."



Ana P., Rio de Janeiro

"Agendamento ágil e **montagem pontual e perfeita**. Recomendo demais!"



Agende agora pelo QR Code

Madeira**Madeira** Serviços · Atendimento em todo o Brasil



Escaneie o QRCode