

Lista das peças/List parts/ Listas de las piezas

N°	Código	Descrição	Descripción	Description
0	183-85	KIT FERRAGEM 4810	KIT DE HERRAMIENTAS 4810	TOOL KIT 4810
1	194-15	LATERAL ESQUERDA 800 X 450 X 18 C/M (410/504/800/810)	LADO IZQUIERDO 800X450X18 C/M (410/504/800/810)	LEFT SIDE 800X450X18 W / M (410/504/800/810)
2	173-43	BASE 1503 X 450 X 18 (4810)	BASE 1503X450X18 (4810)	BASE 1503X450X18 (4810)
3	181-12	DIVISAO DIREITA 711 X 430 X 18 C/M (4800)	DIVISION DERECHA 711X430X18 (4800)	RIGHT DIVISION 711X430X18
4	174-0	BATENTE 711 X 55 X 18 (02 FUROS)	PARADA 711X55X18 (02 AGUJEROS)	STOP 711X55X18 (02 HOLES)
5	174-31	BATENTE 1503 X 55 X 18	PARADA 1503X55X18	STOP 1503X55X18
6	174-1	BATENTE 655 X 55 X 18 (01FURO)	PARADA 655X55X18 (01 AGUJERO)	STOP 655X55X18 (01 HOLE)
7	174-2	BATENTE 655 X 55 X 18 (06 FUROS)	PARADA 655X55X18 (06 AGUJEROS)	STOP 655X55X18 (06 HOLES)
8	146-0	TRAVESSA 335 X 55 X 18	PLACA 335X55X18	PLATE 335X55X18
9	188-15	LATERAL DIREITA 800 X 450 X 18 C/M (410/504/800/810)	LADO DERECHO 800X450X18 C/M (410/504/800/810)	RIGHT SIDE 800X450X18 W / M (410/504/800/810)
10	226-1	RODAPE 1503 X 70 X 18	RODAPÍE 1503X70X18	SKIRTING 1503X70X18
11	165-0	PE TORNEADO ENCAIXE M OGNO	CAOBAAJUSTABLE CON PIES	FOOT TURNED FIT MAHOGANY
	165-4	PE TORNEADO ENCAIXE IMBUIA	PIE VUELTO EN FIT IMBUIA	FOOT TURNED IN FIT IMBUIA
12	146-5	TRAVESSA RODAPE 396 X 70 X 20	PLACA RODAPÍE 396X70X20	SKIRTING PLATE 396X70X20
13	226-4	RODAPE AUXILIAR 275 X 71 X 20	RODAPÍE AUXILIAR 275X71X20	AUXILIARY SKIRTING 275X71X20
14	201-25	MESA 1585 X 475 X 18	MESA 1585X475X18	TABLE 1585X475X18
15	193-2	LATERAL 970 X 245 X 16 (4800)	LATERAL 970X245X16 (4800)	SIDE 970X245X16 (4800)
16	231-1	TAM PO SUPERIOR 1115 X 245 X 18	ARRIBA ARRIBA 1115X245X18	TOP TOP 1115X245X18
17	180-16	DIVISAO SUPERIOR 954 X 227 X 16	DIVISION SUPERIOR 954X227X16	TOP DIVISION 954X227X16
18	174-30	BATENTE 954 X 55 X 18 (PORTA VIDRO)	PARADA 954X55 (PUERTA DE CRISTAL)	STOP 954X55X18 (GLASS DOOR)
19	231-25	TAM PO SUPERIOR 1505 X 245 X 16	ARRIBA ARRIBA 1505X245X16	TOP TOP 1505X245X16
20	174-12	BATENTE 466 X 55 X 18	PARADA 466X55X18	STOP 466X55X18
21	217-35	PRATELEIRA 374 X 227 X 16 SEM FURO	ESTANTE 374X227X16 SIN AGUJERO	SHELF 374X227 WITHOUT HOLE
22	217-0	PRATELEIRA 1115 X 215 X 16	ESTANTE 1115X215X16	SHELF 1115X215X16
23	213-1	MOLDURA SUPERIOR 1490 X 55 X 20	MARCO SUPERIOR 1490X55X20	TOP FRAME 1490X55X20
24	179-67	COSTAS 980 X 390 X 4	TRASERO 980X390X4	REAR 980X390X4
25	179-22	COSTAS 1135 X 486 X 4	TRASERO 1135X486X4	REAR 1135X486X4
26	179-1	COSTAS 740 X 355 X 2,5	TRASERO 740X355X2,5	REAR 740X355X2,5
27	179-0	COSTAS 740 X 388 X 2,5	TRASERO 740X388X2,5	REAR 740X388X2,5
28	255-15	PORTA 670 X 343 X 18	PUERTA 670X343X18	DOOR 670X343X18
29	255-16	PORTA VIDRO 480 X 343 X 18	PUERTA CRISTAL 480X343X18	GLASS DOOR 480X343X18
30	255-23	PORTA VIDRO 960 X 343 X 18	PUERTA CRISTAL 960X343X18	GLASS DOOR 960X343X18
31	217-34	PRATELEIRA 787 X 415 X 8	ESTANTE 787X415X8	SHELF 787X415X8
32	184-26	FRENTE GAVETA 350 X 140 X 18 C/M	CAJÓN DELANTERO 350X140X18 C / M	DRAWER FRONT 350X140
33	187-30	FUNDO GAVETA 296 X 440 X 2,5	FONDO CAJON 296X440X2,5	DRAWER BACKGROUND 296X440
34	453-2	LATERAL GAVETA PINTADA 440 X 95 X 12	LADO CAJÓN 440X95X12	DRAWER SIDE 440X95X12
35	454-3	TRASEIRO GAVETA PINTADA 285 X 95 X 12	CAJÓN TRASERO 285X95X12	REAR DRAWER 285X95X12
36	217-36	PRATELEIRA 374 X 227 X 16 COM FURO	ESTANTE 374X227X16 C/ AGUJERO	SHELF 374X227X16 WITH HOLE
37	128-2	CORREDEJA METALICA 450 MM	CORREDERA METÁLICA 400 mm	METALLIC SLIDE 400 mm



MÓVEIS PRINCESA OESTE LTDA.

BR-282 Km 582,5

CEP: 89870-000

Pinhalzinho-SC- Brasil

Fone/fax: +55(49) 3366-1911

www.moveismo.com.br



Móvel Concluído

4810 - kit 07 Portas Genebra

Observações/Observaciones/Observation

* Fixar toda a ferragem indireta antes de começar a montagem. (Dobradiças nas portas, cavilhas nas travessas, etc. Sempre obs. o desenho).

* Fijar todas las piezas metálicas, antes de comenzar el montaje. (Tacos de madera en los laterales, vigas de madera, bisagras, etc. (Siempre mirando el dibujo paso a paso).

* Hinges in the doors, peg in the lates, etc. (Always watching the drawing)

Importante/Important

*Para um bom resultado na montagem dos produtos, siga as instruções como o indicado, respeitando passo a passo a sequência numérica na ordem crescente. Utilize a embalagem do produto para cobrir o chão para evitar riscos nas peças.

* Para un buen resultado en el montaje de los productos, seguir las instrucciones como indica el montaje paso a paso, siempre en orden creciente.

*For a good result in mounting products, follow the instructions, step by step the number sequence.

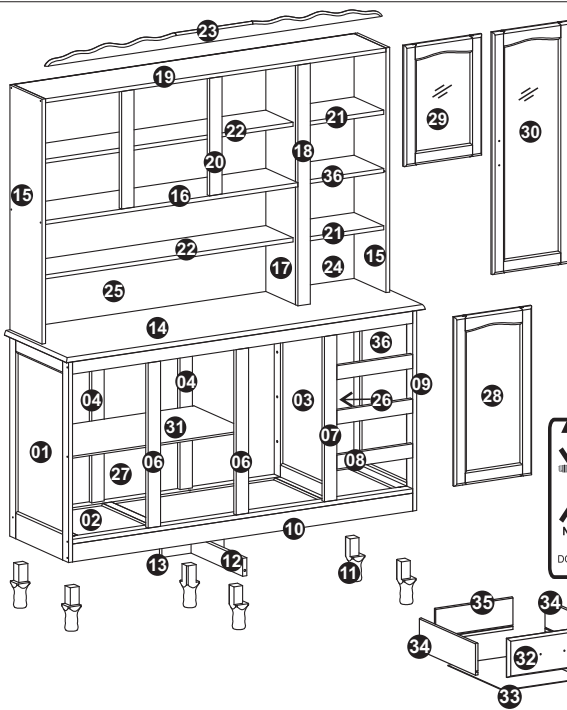

LISTA DE FERRAGENS (Identifying the Hardware/Ferreteria Incluida)				
Código				
162-4	A	Parafuso 3,5x30 mm		22
162-0	B	Parafuso phillips 3,5x12mm		226
162-6	C	Parafuso phillips 3,5 x 40mm		56
331-5	D	Cantoneira 6 furos (Gavetas) 46 X 17 X 17		08
331-1	E	Cantoneira 4 Furos (Mesa/Moldura)		13
120-0	F	Cavilha 8x30mm		81
185-0	G	Prego 12X12		24
196-0	H	Suporte prateleira		22
131-0	I	Dobradiça		14
185-1	J	Prego 8 X 8		150
675-0	K	Puxador Madeira Mogno		11
675-1	K	Puxador Madeira Imbuia Brilho		11
139-1	L	Fecho		07
125-0	M	Cola/Glue		01
162-3	N	Parafuso phillips 3,5 x 22mm		14

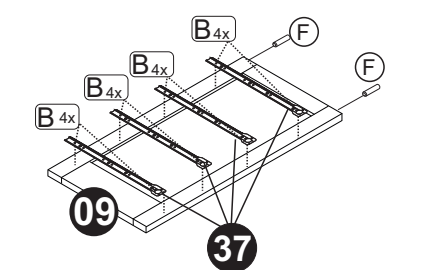
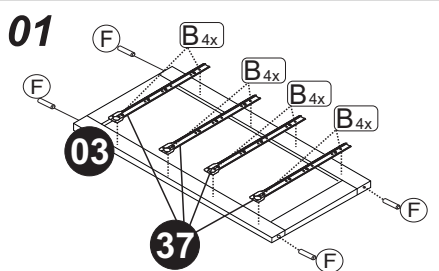
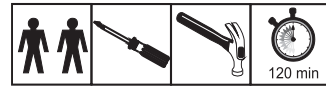

Alinhar a corredeira na parte traseira da peça
Alinee la corredera en la parte posterior de la pieza.
Align the slide at the rear of the part.

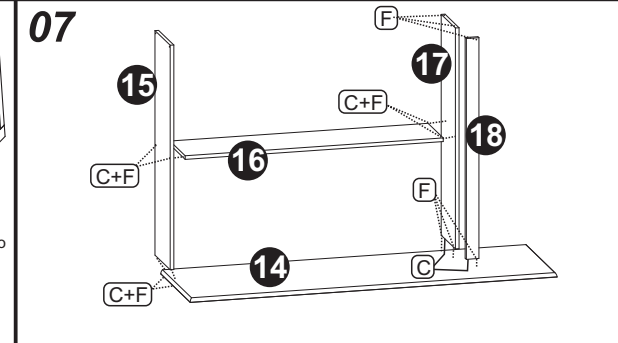
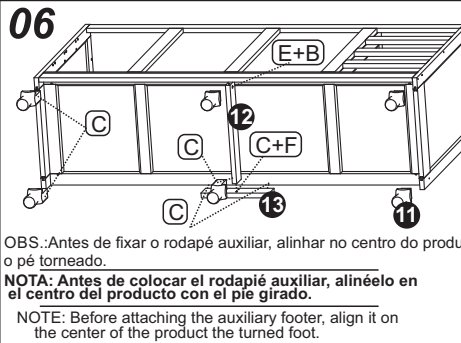
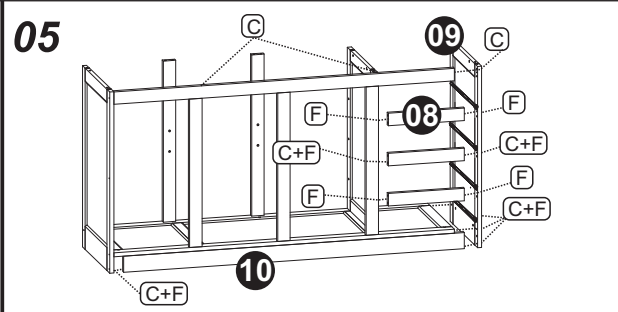
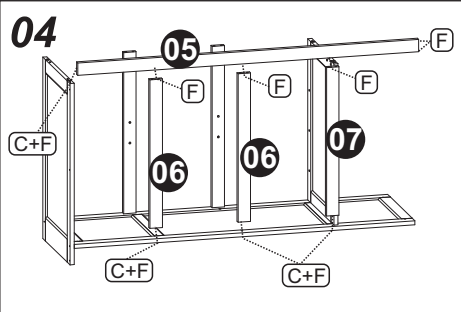
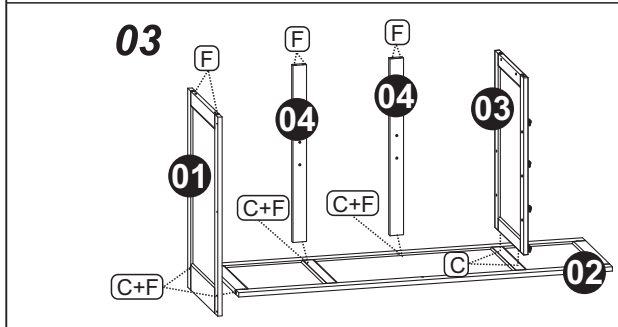
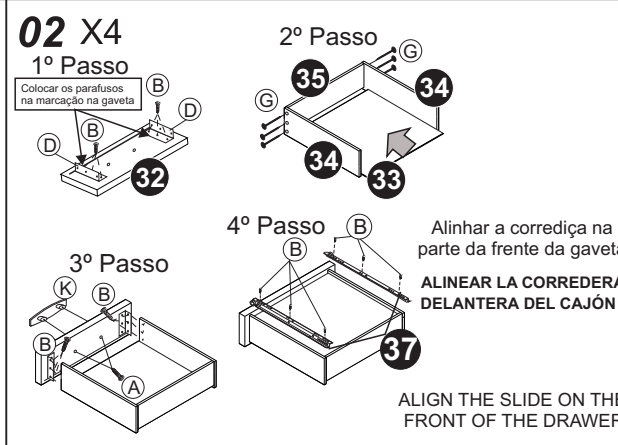

OBS: Antes de fixar o rodapé auxiliar, alinhar no centro do produto o pé torneado.
NOTA: Antes de colocar el rodapé auxiliar, alinéelo en el centro del producto con el pie girado.
NOTE: Before attaching the auxiliary footer, align it on the center of the product the turned foot.

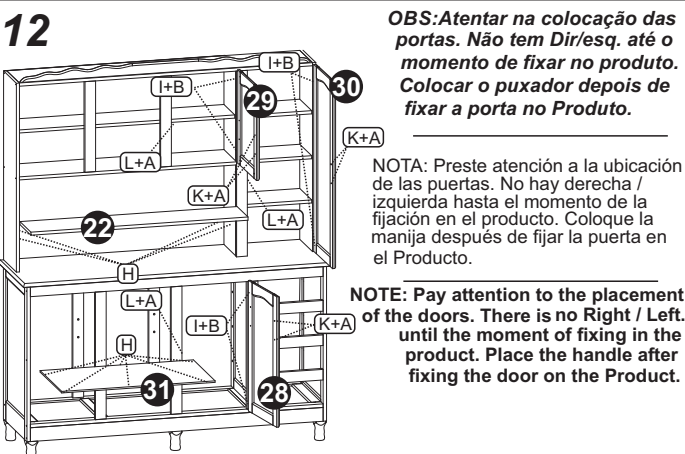
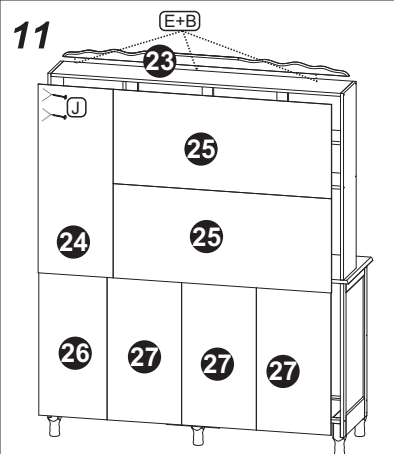
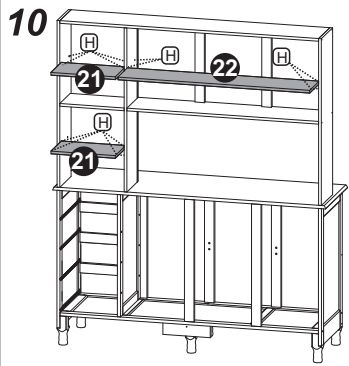
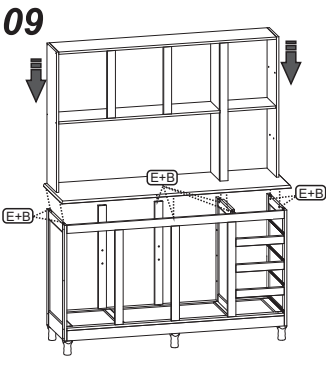
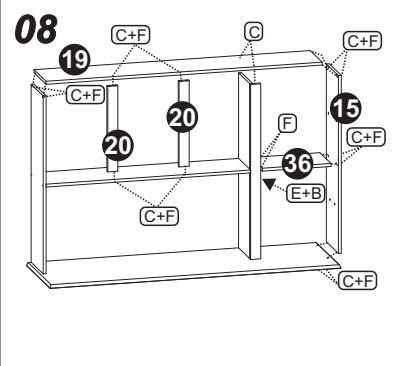

OBS: Atentar na colocação das portas. Não tem Dir/esq. até o momento de fixar no produto. Colocar o puxador depois de fixar a porta no Produto.
NOTA: Preste atención a la ubicación de las puertas. No hay derecha / izquierda hasta el momento de la fijación en el producto. Coloque la manija después de fijar la puerta en el Producto.
NOTE: Pay attention to the placement of the doors. There is no Right / Left until the moment of fixing in the product. Place the handle after fixing the door on the Product.