

Capacidade de Carga - Load Capacity - Capacidad de carga

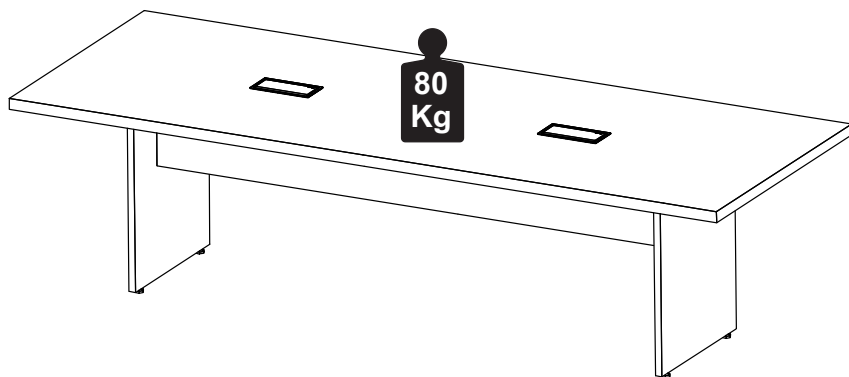

Manutenção e Limpeza

Vidros: pano levemente umedecido com álcool, seguido de pano seco.
Madeiras: pano levemente umedecido com água, seguido de pano seco.
*Nunca utilizar produtos químicos ou abrasivos.

Maintenance and Cleaning

Glasses: cloth lightly moistened with alcohol, followed by dry cloth.
Woods: cloth slightly moistened with water, followed by cloth seo.
*Never use chemicals or abrasives.

Mantenimiento y Limpieza

Vidrios: legeramente humedecido con alcohol, seguido de un paño seco.
Madera: ligeramente humedecido con agua, seguido de un paño seco.
*No utilice nunca productos quimicos o abrasivos.

INSTRUÇÕES DE MONTAGEM ASSEMBLY INSTRUCTIONS INSTRUCCIONES DE MONTAJE

MESA DE REUNIÃO CONFERENCE TABLE MESA DE CONFERENCIA

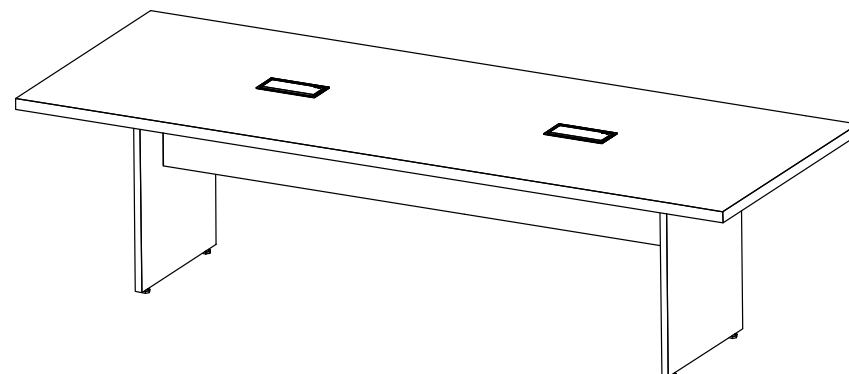

REF. #SAT2090-2190-2790-2092-2192
REF. #PRS2010-2011-2710-2711
REF. #EXP2090.2190

F5 Office
MÓVEIS CORPORATIVOS

Empresa do Grupo:



1 P.



8mm



20mm

LISTA DE PEÇAS

- 01 - Painel Lateral
- 02 - Tampo
- 04 - Painel Frontal

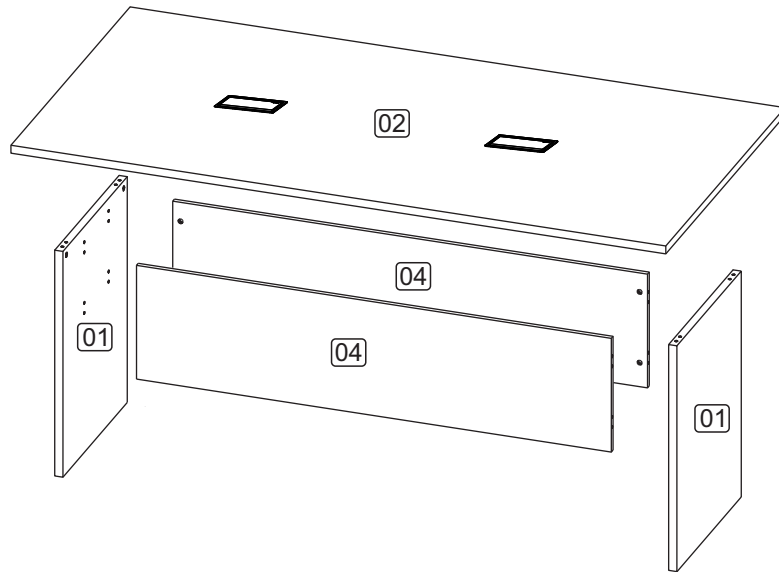

LISTA DE PIEZAS

- 01 - Panel Lateral
- 02 - Tapa
- 04 - Panel Delantero

PARTS IDENTIFICATION

- 01 - Panel Side
- 02 - Top
- 04 - Front Panel

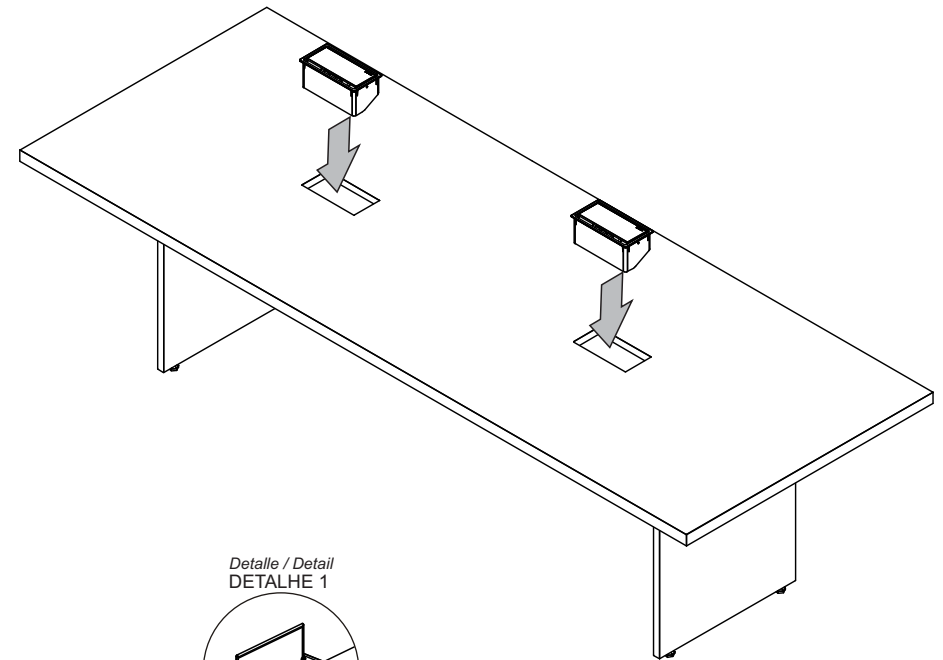

Detalle / Detail
DETALHE 1

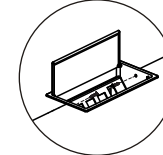

Ver manual de montagem da caixa.
Consulte el manual de montaje de la caja.
See box assembly manual.

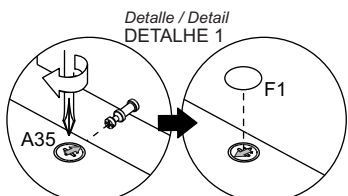
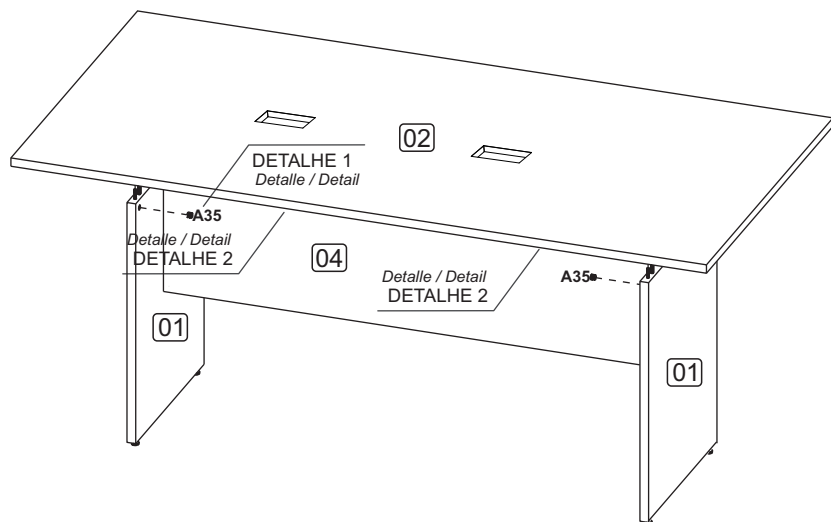

Depois de encaixar as peças coloque o tambor com a sua seta voltada para o parafuso. Para apertar Gire no sentido horário.
 Después de colocar las piezas, coloque el tambor con su flecha hacia el tornillo. Para apretar, gire en sentido horario.
 After fitting the parts, place the drum with its arrow facing the screw. To tighten, turn clockwise.

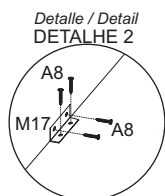

Posicione a cantoneira encostada na quina das peças.
 Coloque la ángulo contra la esquina de las piezas.
 Position the corner against the corner of the pieces.

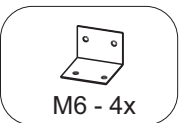
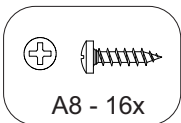
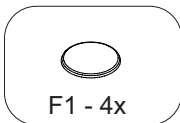
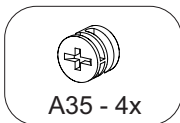

ACESSÓRIOS ACCESSORIES ACCESORIOS

A8 - PARAF. 4,0x14 CP
16x

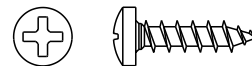

A29 - PARAF. MINIFIX
 M6x33m **12x**

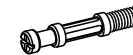

A35 - TAMBOR
 MINIFIX **12x**



A36 - BUCHA M6x33
12x



D1 - CAVILHA 8x30
12x

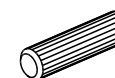

F1 - TAPA FURO Ø18
04x



L2 - SAPATA PLAST.
 SEXT. **4x**



L5 - BUCHA PLÁSTICA
 P/SAPATA 5/16 **4x**



M6 - CANTONEIRA L
 04 FUROS **4x**



1 PRÉ-MONTAGEM

Preasamblea
Pre-assembly

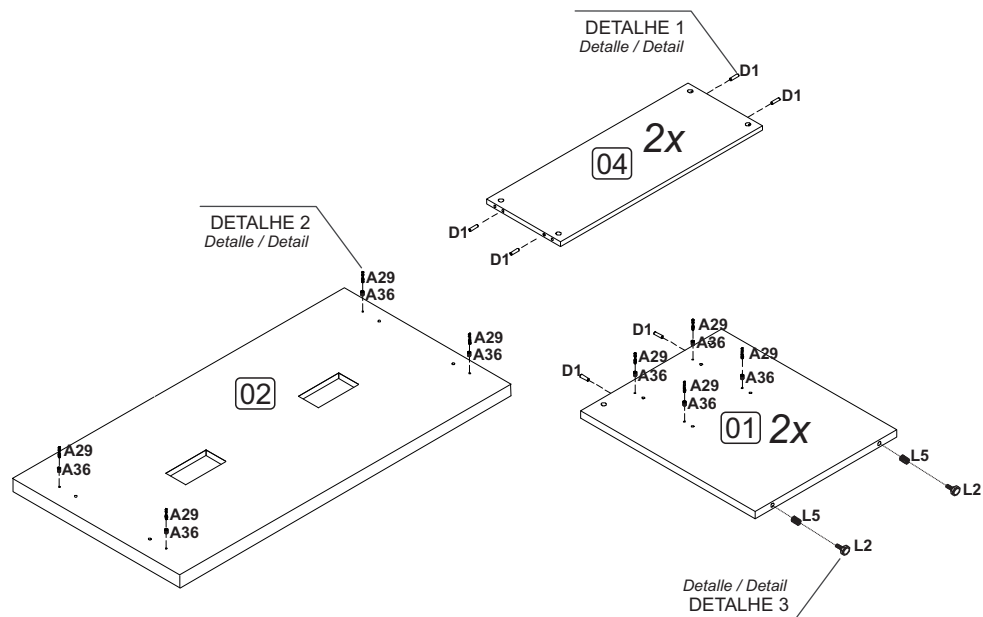

Detalle / Detail
DETALHE 1



Pressione até o fundo do furo.
Se necessário utilize um martelo de borracha.
Presione hasta el fondo del agujero.
Si es necesario, utilice un mazo de goma.
Press to the bottom of the hole.
If necessary use a rubber mallet.

Detalle / Detail
DETALHE 2

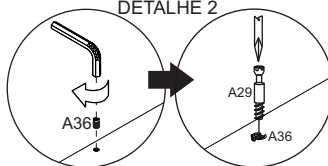

Com uma chave allen insira a bucha na peça, apos, rosqueie o parafuso.
Con una llave Allen, inserte el mandril en la pieza y luego atornille el tornillo.
Using an Allen key, insert the chuck into the part, then screw the screw.

Detalle / Detail
DETALHE 3

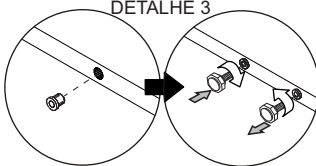

Insira a bucha com um martelo e rosqueie a sapata.
Inserte el portabrocas con un martillo y atornille la zapata.
Insert the chuck with a hammer and screw the shoe.

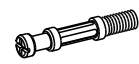

A29 - 12x



A36 - 12x



D1 - 12x



L2 - 4x



L5 - 4x

2 MONTAGEM

Armado
Assembly

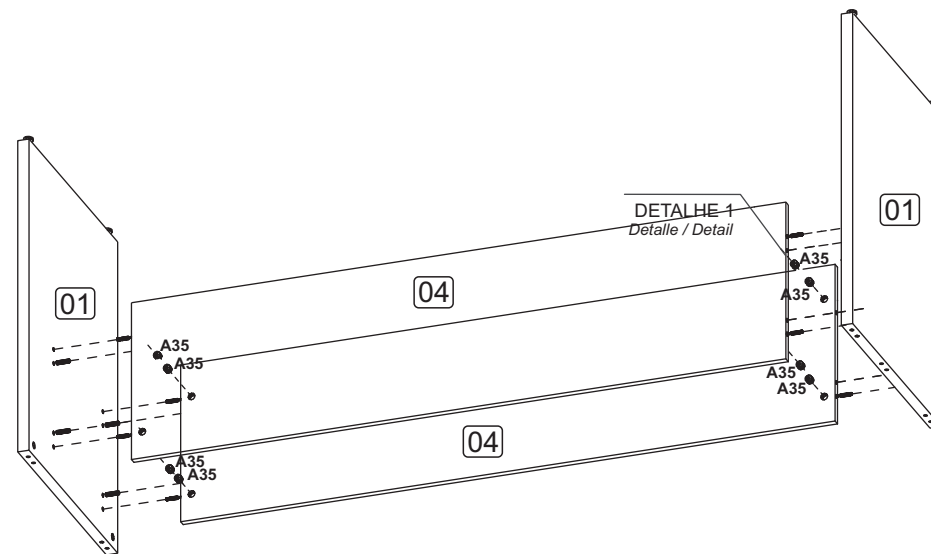

Detalle / Detail
DETALHE 1

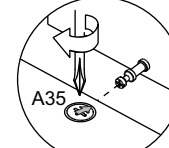

Depois de encaixar as peças coloque o tambor com a sua seta voltada para o parafuso. Para apertar Gire no sentido horário.
Después de colocar las piezas, coloque el tambor con su flecha hacia el tornillo. Para apretar, gire en sentido horario.
After fitting the parts, place the drum with its arrow facing the screw.
To tighten, turn clockwise.



A35 - 8x