



MAVAULAR móveis

Fone (32) 3539-7600

Rod. Ubá - Rodeiro, Km 03 - Galpão 1

C. P. 050 - CEP 36500-000 - Ubá - MG

E-mail: mavoular@mavoular.com.br - Site: www.mavoular.com.br

Facebook and Instagram icons followed by Mavoular Móveis



Instruções de Montagem Painel Atenas 1800

Panel Atenas 1800 Assembly Instructions

Instrucciones de montaje del Panel Atenas 1800

CÓDIGO: 10916

Atualizado em: 16/05/2025

CUIDE BEM DO SEU MÓVEL

Dicas de limpeza e conservação:

- Para limpar corretamente seu produto, use sempre um pano liso e **levemente** umedecido com água;
- Não se esqueça de enxugar o seu móvel! Ele não deve permanecer úmido, pois a água pode prejudicar o acabamento ou causar mofo na madeira;
- Não se recomenda o uso de produtos à base de amoníaco.
- Não utilize esponja de aço ou qualquer material que possa arranhar a superfície do produto durante a limpeza.
- Não utilize plásticos ou papéis coloridos para forrar seu móvel.
- Evite arrastar objetos em cima do móvel. Eles podem riscar e prejudicar o acabamento de seu móvel de
- O material dos seus móveis tem um tratamento contra fungos e cupins, mesmo assim, em ambientes infestados recomenda-se a dedetização antes de instalar a seu móvel;
- Tente evitar a exposição direta ao sol. Sugere-se utilização de cortinas para proteger seu móvel;

TAKING GOOD CARE OF YOUR FURNITURE

Cleaning and caring instructions:

- Wipe the wood furniture down with a moist cloth to properly clean the furniture.
- Do not forget to dry your furniture out. Humidity can damage the finish or create mould.
- Chemical products are not recommended;
- Never clean the furniture with scouring powders, steel scrubber pads or any other product which can scratch its surface.
- Furniture surfaces should not be covered with colored plastic or paper sheets.
- Avoid dragging objects on top of the furniture. They might scratch the finishing.
- Wood furniture are made of mould and termites resistant materials, however, it is recommended to use termiticides in infested places before installing the furniture.
- Avoid furniture exposure to direct Sun light. Drapers suggested.

CUIDE BIEN DE SU MUEBLE

Indicaciones de limpieza y conservación

- Para limpiar correctamente su muebles de madera, siempre use un paño húmedo.
- No se olvide de secar su muebles! No debe permanecer húmedo, pues el agua puede perjudicar el acabado o causar moho en la madera.
- No es recomendable utilizar productos con amoníaco.
- No utilizar esponjas de acero o cualquier material que dañe la superficie de los muebles.
- No utilizar plásticos o papeles coloridos para forrar los muebles.
- Evite arrastrar objetos encima de los muebles. Ellos pueden riscar o dañar el acabado de su mueble de cocina.
- El material de los muebles tiene un tratamiento contra los hongos y las polillas, aun así, en ambientes infectados, se recomienda desinfectar antes de instalar su mueble.
- Evite la exposición directa al sol. Se sugiere la utilización de cortinas para proteger sus muebles.

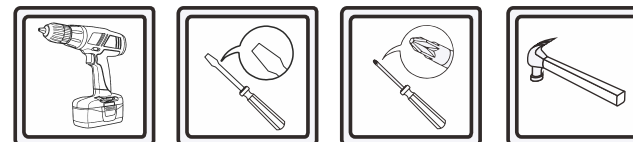
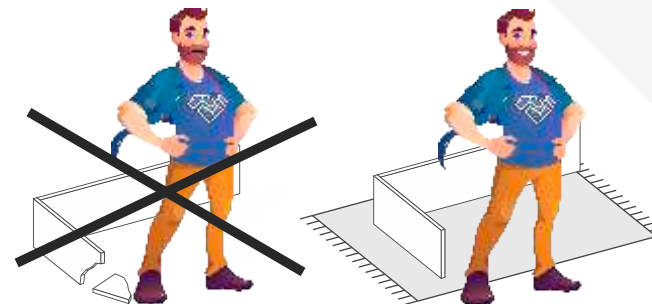
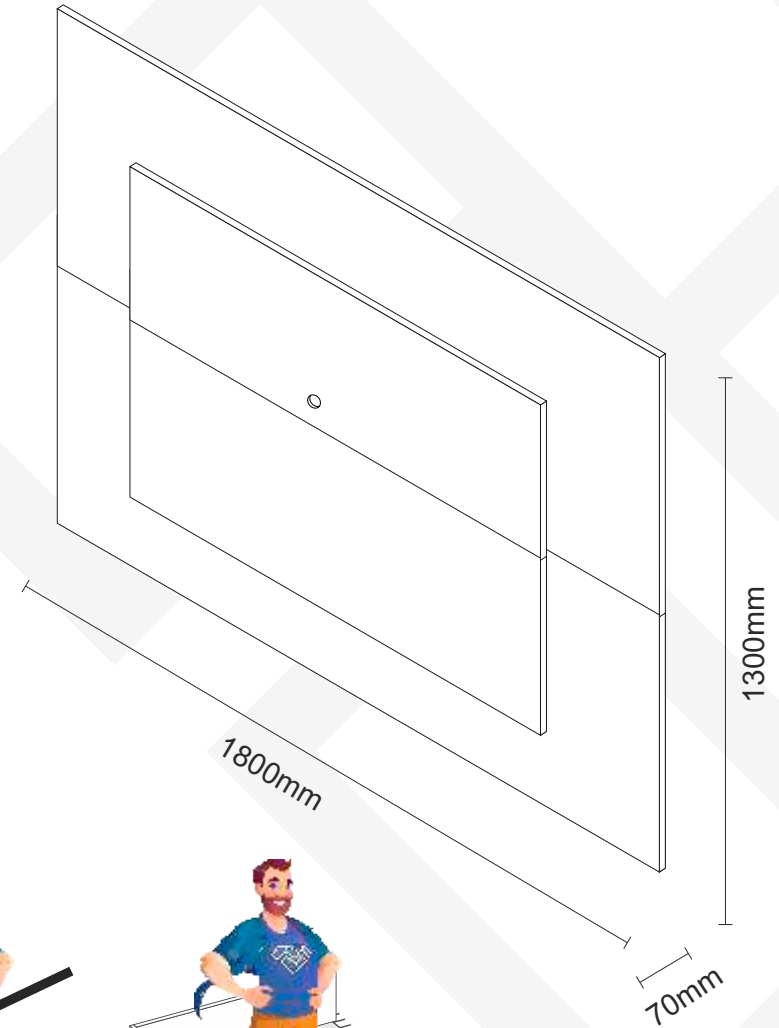

As ferramentas necessárias para montagem do produto não são fornecidas.

The necessary tools for assembly aren't supplied.

Las herramientas necesarias para armar los productos no son fornecidas.

N°	CÓDIGO CODE CÓDIGO	DESCRIÇÃO DESCRIPTION DESCRIPCIÓN			DIMENSÃO (mm) DIMENSION (mm) DIMENSIÓN (mm)			QUANTIDADE QUANTITY CANTIDAD
					COMP. LEN. LON.	LARG. WID. ANC.	EPS DEP ESP	
1	10936	Painel Central Superior	Upper Center Panel	Panel central superior	1400	450	15	1
2	10941	Painel Central Inferior	Lower Central Panel	Panel central inferior	1400	450	15	1
3	10935	Moldura de União	Union Frame	Marco de unión	450	70	15	2
4	10933	Apoio Inferior / Superior	Bottom / Top Support	Soporte inferior/superior	1190	70	25	2
5	10921	Apoio Lateral	Lateral Support	Soporte lateral	840	70	25	2
6	10934	Painel Lateral Traseiro	Rear Side Panel	Panel lateral trasero	1800	355	15	1
7	10924	Painel Superior Traseiro	Rear Upper Panel	Panel superior trasero	590	305	15	1
8	10940	Painel Inferior Traseiro	Rear Lower Panel	Panel inferior trasero	1800	355	15	1
9	10932	Moldura Superior do Painel	Upper Panel Frame	Marco del panel superior	1540	70	15	1
10	10925	Moldura Lateral do Painel	Panel Side Frame	Marco lateral del panel	1280	70	15	2
11	10927	Moldura Inferior do Painel	Lower Panel Frame	Marco del panel inferior	600	70	15	1
12	10937	Moldura Maior Parede	Larger Wall Frame	Marco de pared más grande	1400	70	15	1
13	10931	Moldura Menor Parede	Minor Wall Frame	Marco de pared menor	600	70	15	1

A - CAVILHA MADEIRA 6X25MM
6X25MM WOODEN DOWEL
TARUGO DE MADEIRA 6X25MM **x02**



F - SACHÊ DE COLA
GLUE BAG
BOLSA DE PEGAMENTO **x02**



J - FITA DE LED
LED TAPE
CINTA DE LED **x01**



B - PARAFUSO 4,5X25MM
4,5X25MM SCREW
TORNILLO 4,5X25MM **x61**



G - CHAPA RETA
STRAIGHT PLATE
PLACA RECTA **x07**



K - PARAFUSO 3,5X30MM
3,5X30MM SCREW
TORNILLO 3,5X30MM **x20**



C - PASSA FIO
WIRE PASS
PASO DE ALAMBRE **x01**



H - PARAFUSO 3,5X12MM
3,5X12MM SCREW
TORNILLO 3,5X12MM **x28**

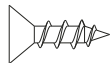

D - PARAFUSO 4,8X45MM
4,8X45MM SCREW
TORNILLO 4,8X45MM **x06**

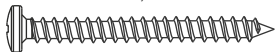

I - CAVILHA MADEIRA 8X50MM
8X50MM WOODEN DOWEL
TARUGO DE MADEIRA 8X50MM **x02**



E - BUCHA 8MM
8MM BUSHING
BUJE 8MM **x06**

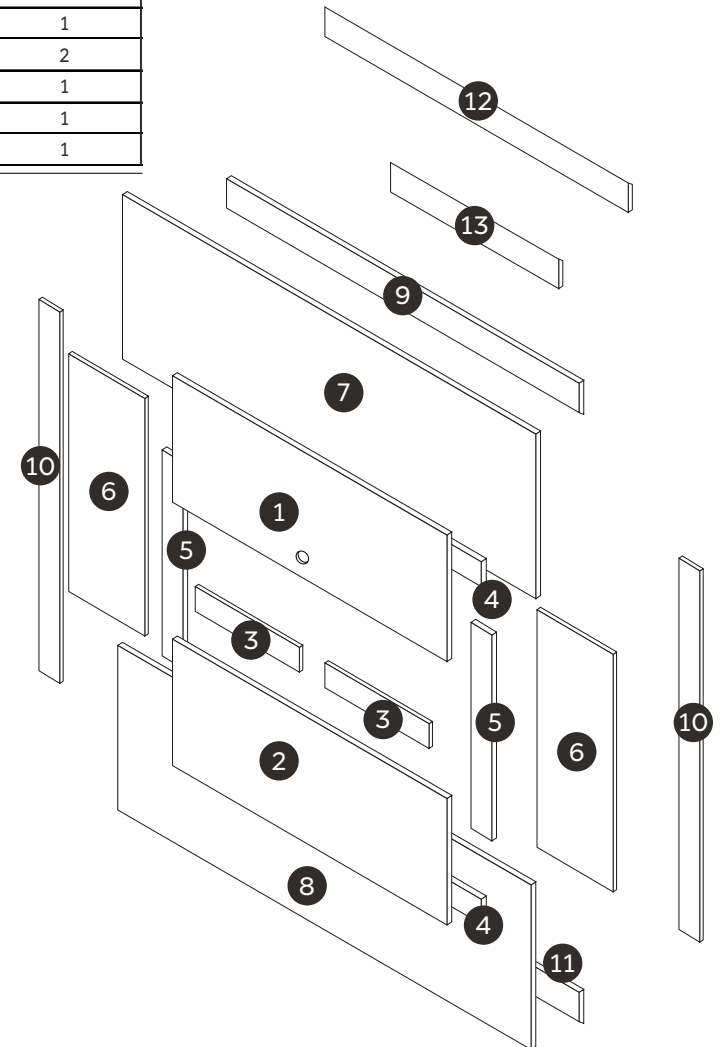
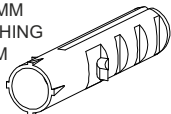

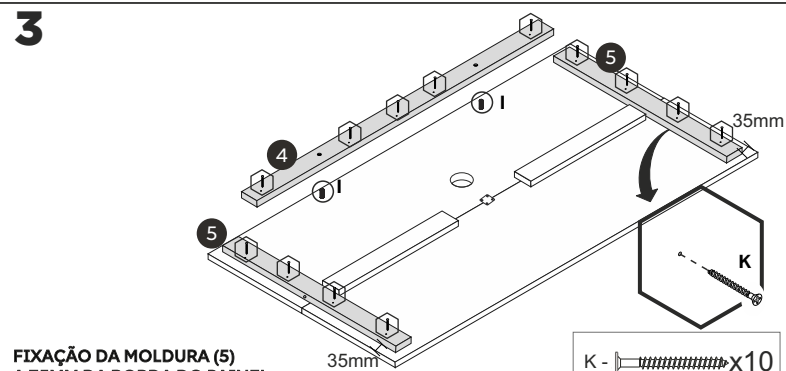
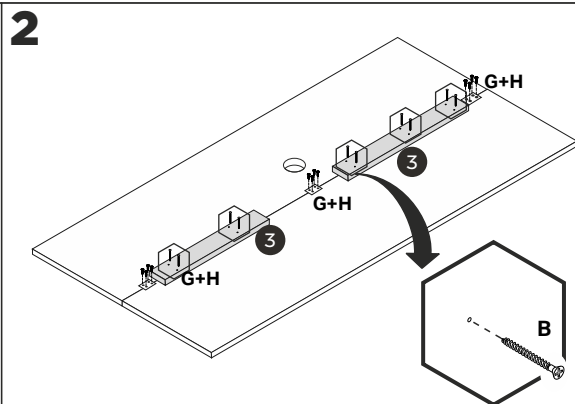
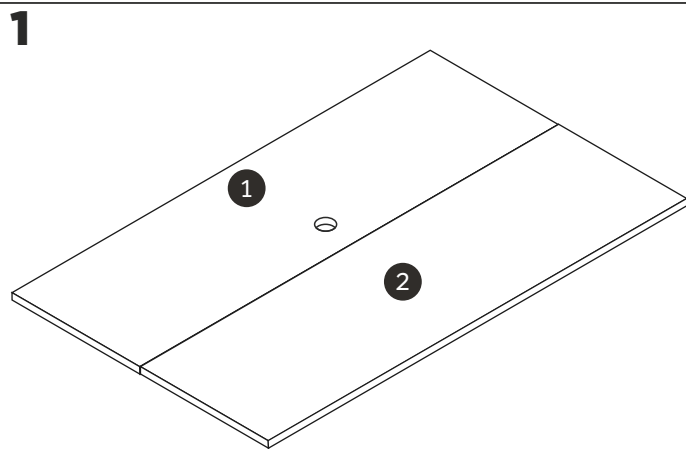

**FIXAÇÃO DA MOLDURA (5)
A 35MM DA BORDA DO PAINEL**
FIXING THE FRAME (5)
35MM FROM THE EDGE OF THE PANEL
FIJACIÓN DEL MARCO (5)
35 MM DESDE EL BORDE DEL PANEL

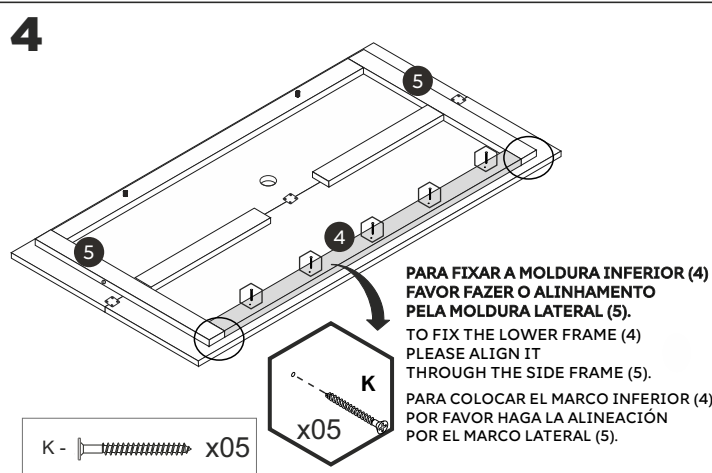
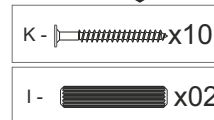

K - x05

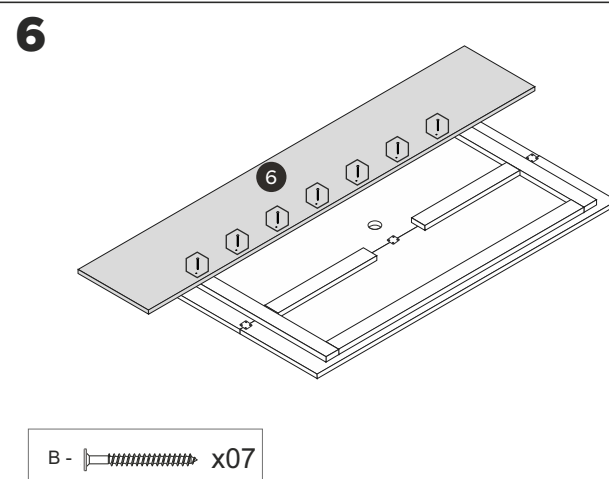
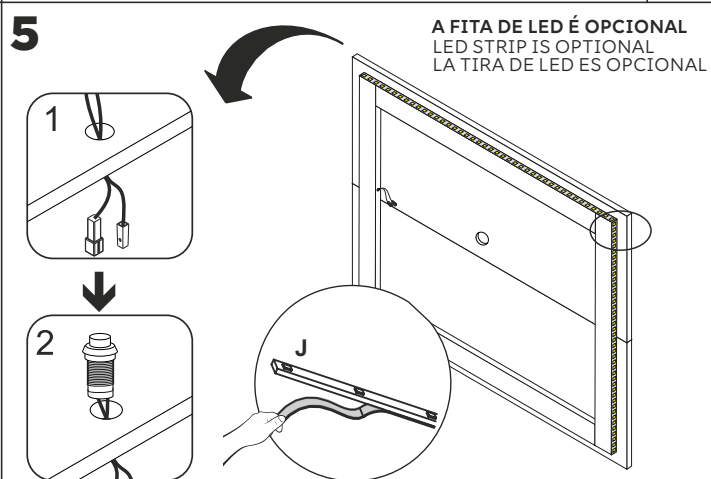

B - x07

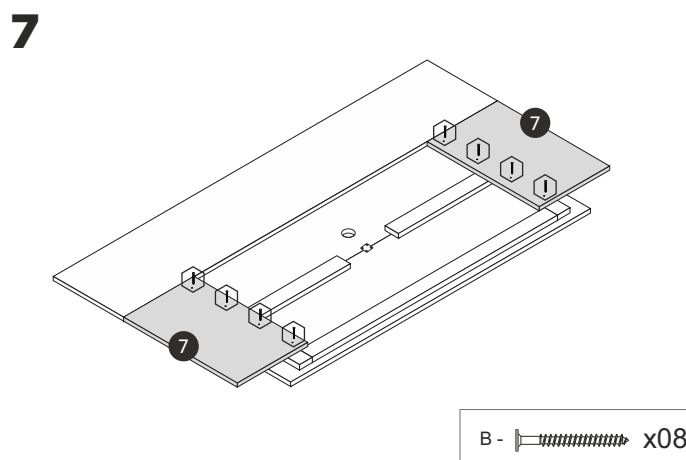

B - x08

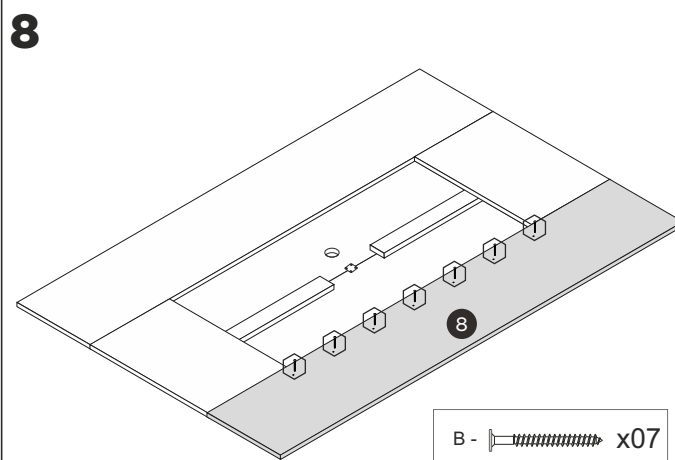

B - x07

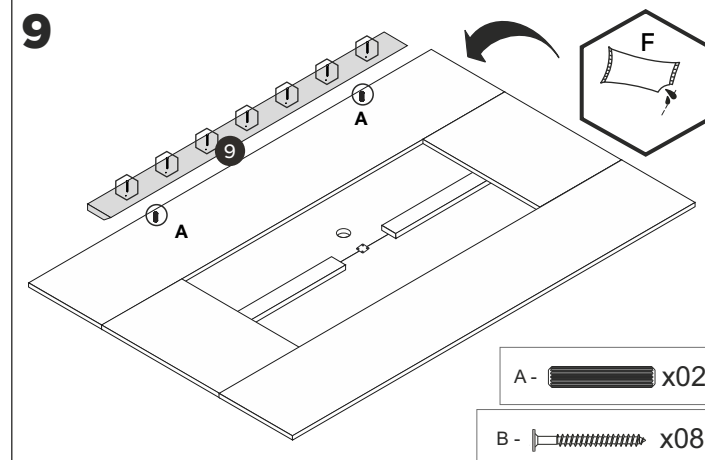

A - x02

B - x08

10

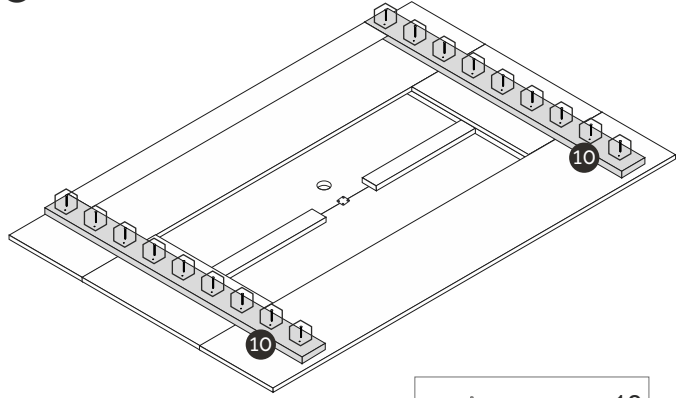

B -  x18

11

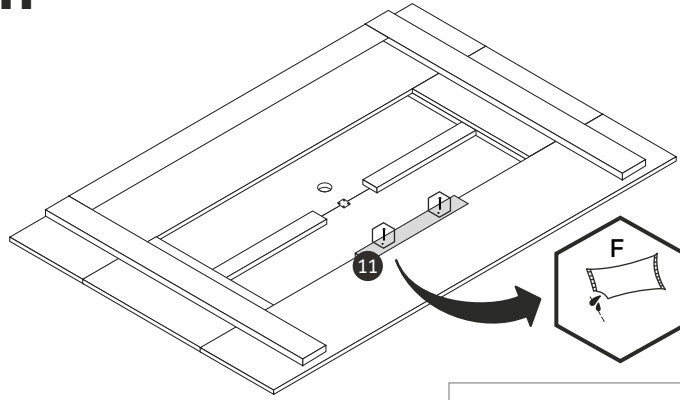

B -  x02

12

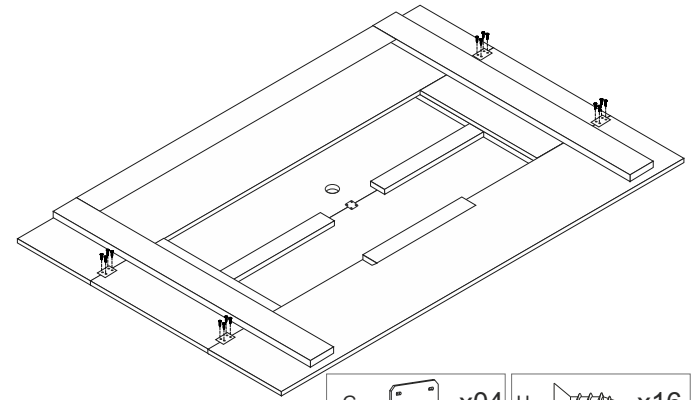

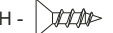
G -  x04 H -  x16

13

8mm - 5/16"

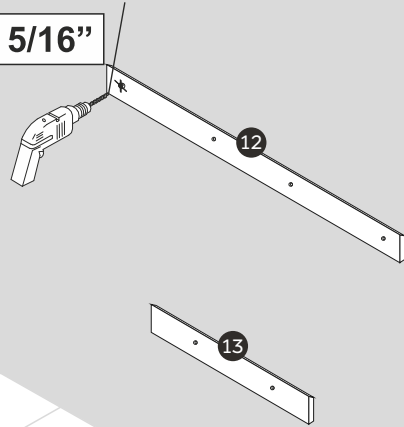

14

8mm - 5/16"

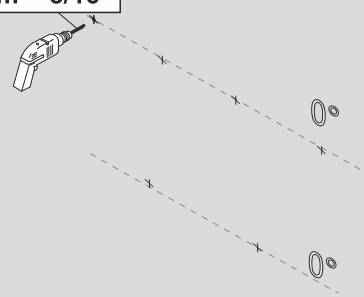

15

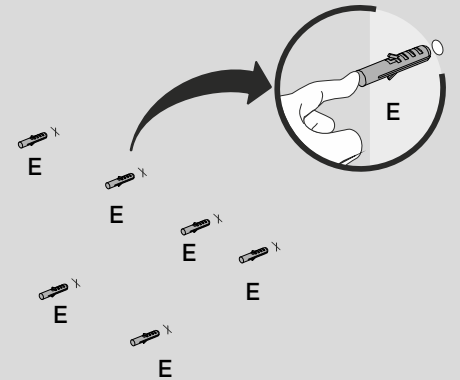

E -  x06

16

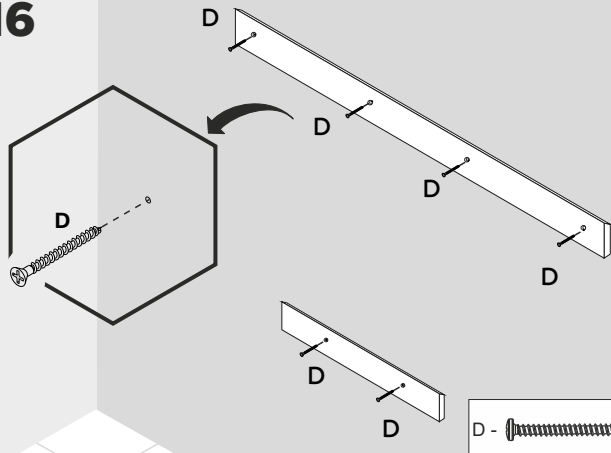

D -  x06

17

C -  x01

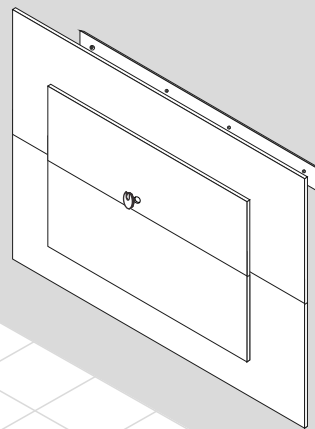

18

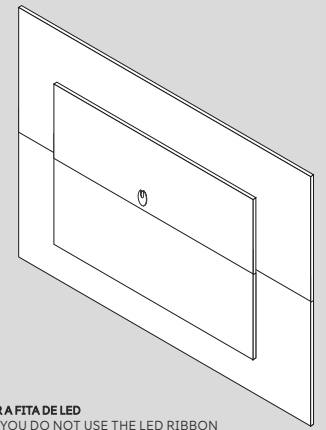

IMPORTANTE USAR TAPA FURO ADESIVO SE NÃO USAR A FITA DE LED
IMPORTANT TO USE ADHESIVE HOLE COVER IF YOU DO NOT USE THE LED RIBBON
IMPORTANTE UTILIZAR ADHESIVO TAPA AGUJERO SI NO UTILIZA LA CINTA LED



MAVAULAR móveis

Fone (32) 3539-7600

Rod. Ubá - Rodeiro, Km 03 - Galpão 1
C. P. 050 - CEP 36500-000 - Ubá - MG
E-mail: mavaular@mavaular.com.br - Site: www.mavaular.com.br

Mavaular Móveis



Instruções de Montagem Rack Viena 2 gavetas 2024

Assembly Instructions Viena Tv stand
Instrucciones de montaje Soporte TV Viena

CÓDIGO: 11132

Atualizado em:
16/01/2024

CUIDE BEM DO SEU MÓVEL

Dicas de limpeza e conservação:

- Para limpar corretamente seu produto, use sempre um pano liso e **levemente** umedecido com água;
- Não se esqueça de enxugar o seu móvel! Ele não deve permanecer úmido, pois a água pode prejudicar o acabamento ou causar mofo na madeira;
- Não se recomenda o uso de produtos à base de amoníaco.
- Não utilize esponja de aço ou qualquer material que possa arranhar a superfície do produto durante a limpeza.
- Não utilize plásticos ou papéis coloridos para forrar seu móvel.
- Evite arrastar objetos em cima do móvel. Eles podem riscar e prejudicar o acabamento de seu móvel de
- O material dos seus móveis tem um tratamento contra fungos e cupins, mesmo assim, em ambientes infestados recomenda-se a dedetização antes de instalar a seu móvel;
- Tente evitar a exposição direta ao sol. Sugere-se utilização de cortinas para proteger seu móvel;

TAKING GOOD CARE OF YOUR FURNITURE

Cleaning and caring instructions:

- Wipe the wood furniture down with a moist cloth to properly clean the furniture.
- Do not forget to dry your furniture out. Humidity can damage the finish or create mould.
- Chemical products are not recommended;
- Never clean the furniture with scouring powders, steel scrubber pads or any other product which can scratch its surface.
- Furniture surfaces should not be covered with colored plastic or paper sheets.
- Avoid dragging objects on top of the furniture. They might scratch the finishing.
- Wood furniture are made of mould and termites resistant materials, however, it is recommended to use termiticides in infested places before installing the furniture.
- Avoid furniture exposure to direct Sun light. Drapers suggested.

CUIDE BIEN DE SU MUEBLE

Indicaciones de limpieza y conservación

- Para limpiar correctamente su muebles de madera, siempre use un paño húmedo.
- No se olvide de secar su muebles! No debe permanecer húmedo, pues el agua puede perjudicar el acabado o causar moho en la madera.
- No es recomendable utilizar productos con amoníaco.
- No utilizar esponjas de acero o cualquier material que dañe la superficie de los muebles.
- No utilizar plásticos o papeles coloridos para forrar los muebles.
- Evite arrastrar objetos encima de los muebles. Ellos pueden riscar o dañar el acabado de su mueble de cocina.
- El material de los muebles tiene un tratamiento contra los hongos y las polillas, aun así, en ambientes infectados, se recomienda desinfectar antes de instalar su mueble.
- Evite la exposición directa al sol. Se sugiere la utilización de cortinas para proteger sus muebles.

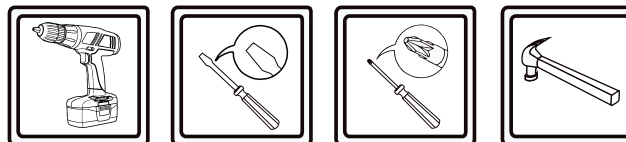
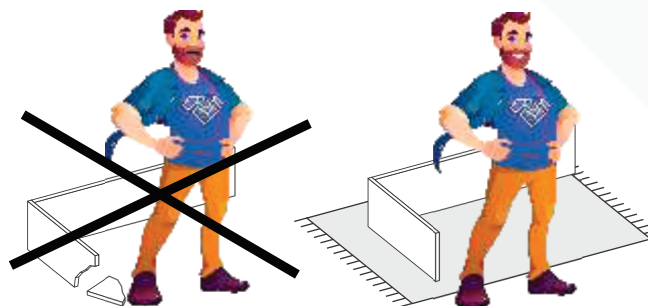
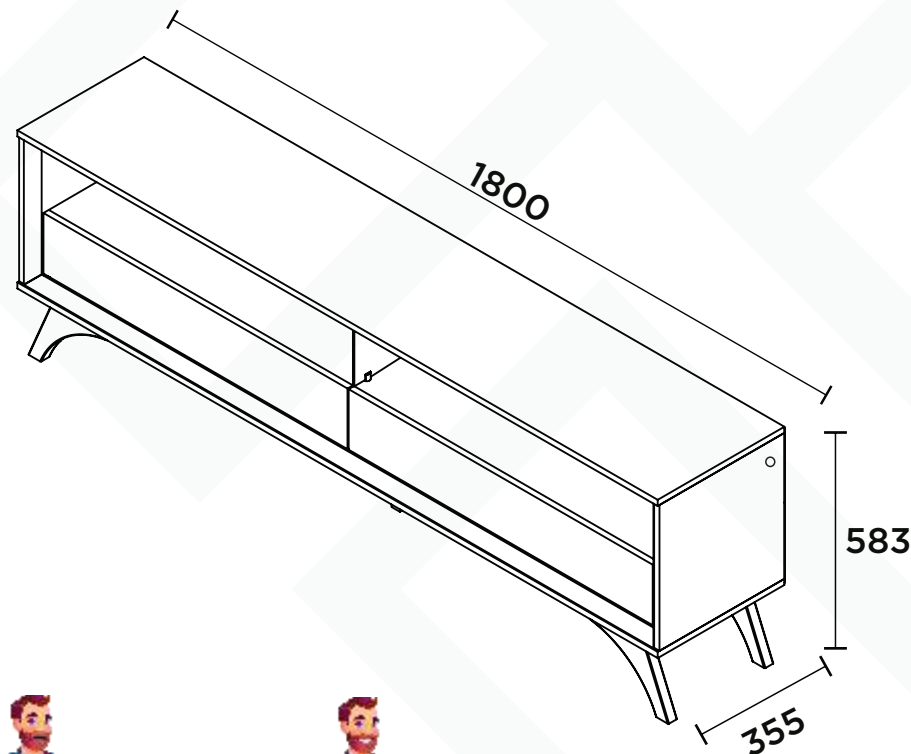

As ferramentas necessárias para montagem do produto não são fornecidas.
The necessary tools for assembly aren't supplied.
Las herramientas necesarias para armar los productos no son fornecidas.

N°	CÓDIGO CODE CÓDIGO	DESCRIÇÃO DESCRIPTION DESCRIPCIÓN			DIMENSÃO (mm) DIMENSION (mm) DIMENSIÓN (mm)			QUANTIDADE QUANTITY CANTIDAD
					COMP. LEN. LON.	LARG. WID. ANC.	ESP. DEP. ESP.	
1	12929	Base	Basis	Base	1800	355	15	1
2	10841	Pé de madeira	Wooden foot	Pie de madera	200	160	30	4
3	7174	Pé central	Center foot	Pie central	197	60	30	1
4	12930	Lateral externa direita	Right external side	Lado exterior derecho	354	350	15	1
5	13127	Lateral externa esquerda	Left external side	Lado exterior izquierdo	354	350	15	1
6	12928	Tampo	Cover	Tapa superior	1800	355	15	1
7	12924	Lateral interna direita	Right internal side	Lado interno derecho	352	350	25	1
8	13148	Lateral interna esquerda	Left internal side	Lado interno izquierdo	352	350	25	1
9	12926	Vista traseira	Upper back frame	Marco superior trasero	1785	80	25	1
10	13149	Vista traseira superior rasgada	Upper back frame	Marco superior trasero	1785	80	25	1
11	12932	Lateral menor direita	Right small side	Lado pequeño derecho	309	152	15	1
12	12925	Vista frontal	Front top frame	Marco superior delantero	1785	80	25	2
13	13145	Lateral menor esquerda	Left small side	Lado pequeño izquierdo	309	152	15	1
14	11147	Divisão	Division	División	309	152	25	1
15	12931	Tampo intermediario	Shelf	Estante	1714	310	15	1
16	11076	Divisão de vidro	Glass division	División de vidrio	300	125	4	1
17	12937	Costas inferior	Lower back	Respaldo inferior	1789	197	3	1
18	12938	Costas superior	Upper back	Respaldo superior	1789	180	3	1
19	13147	Lateral direita da gaveta	Right side of drawer	Lateral cajón derecha	300	96	15	2
20	12934	Lateral esquerda da gaveta	Left side of drawer	Lateral cajón izquierda	300	96	15	2
21	2000	Frente de gaveta	Front of drawer	Frente cajón	852	168	15	2
22	12939	Fundo de gaveta	Drawer bottom	Fondo cajón	787	298	3	2
23	12935	Traseiro de gaveta	Back of drawer	Respaldo cajón	773	90	15	2

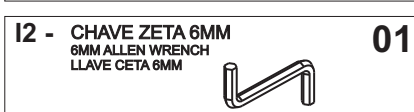
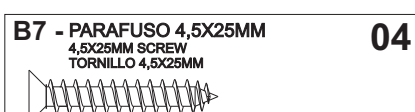
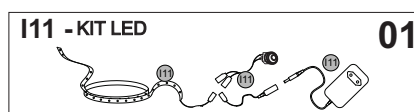
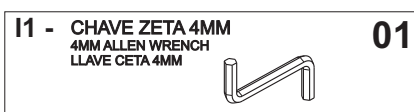
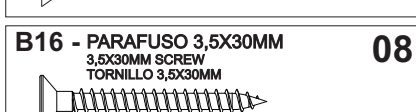
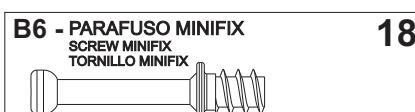
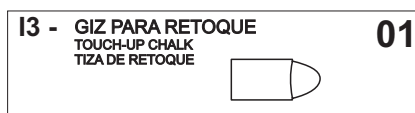
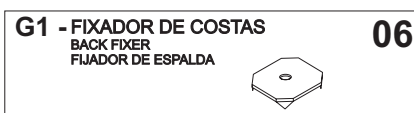
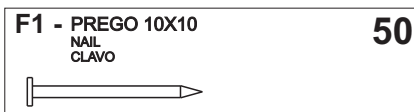
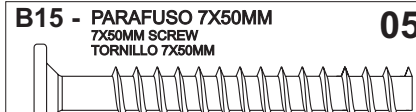
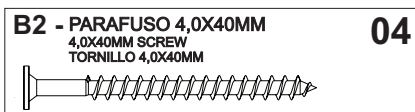
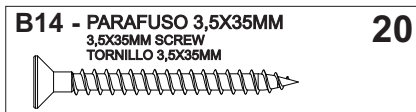
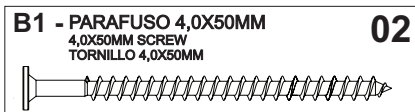
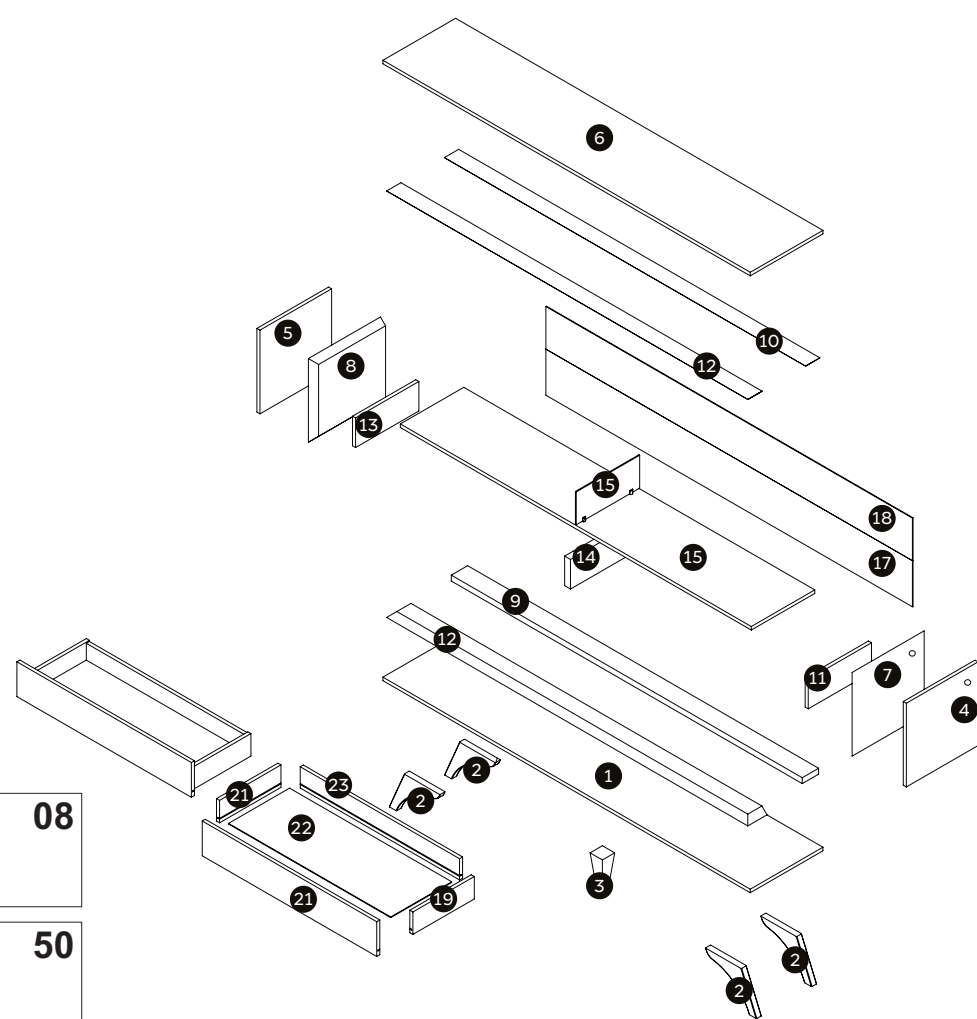

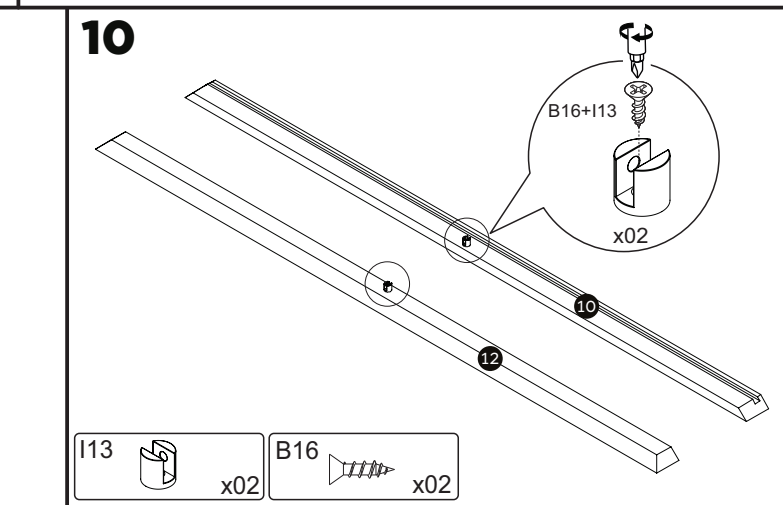
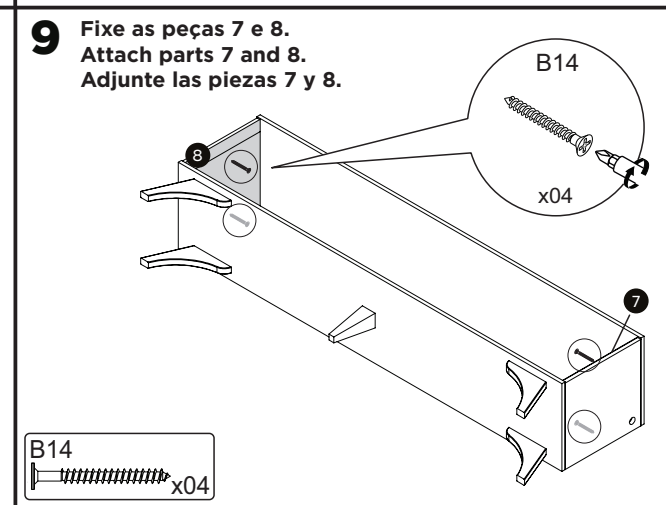
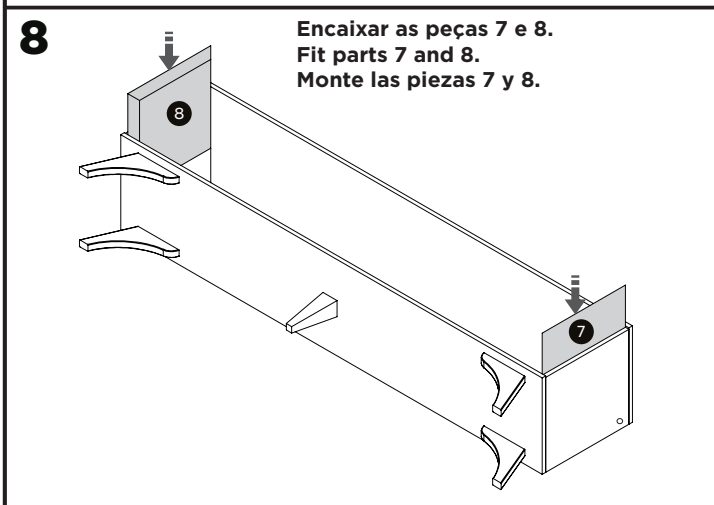
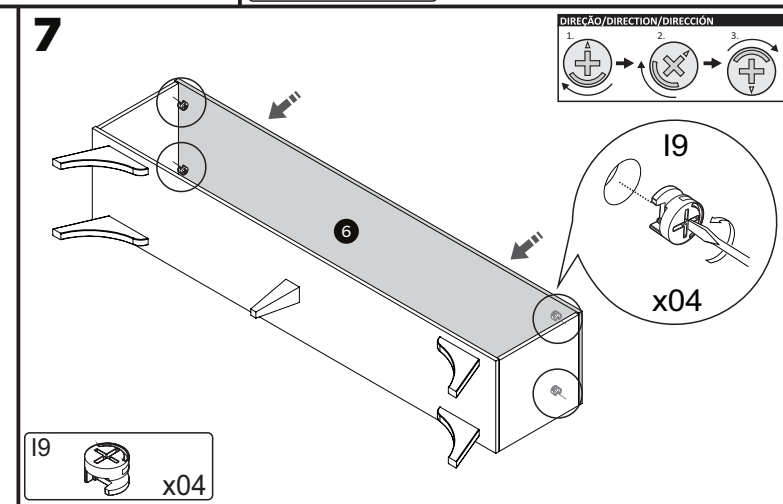
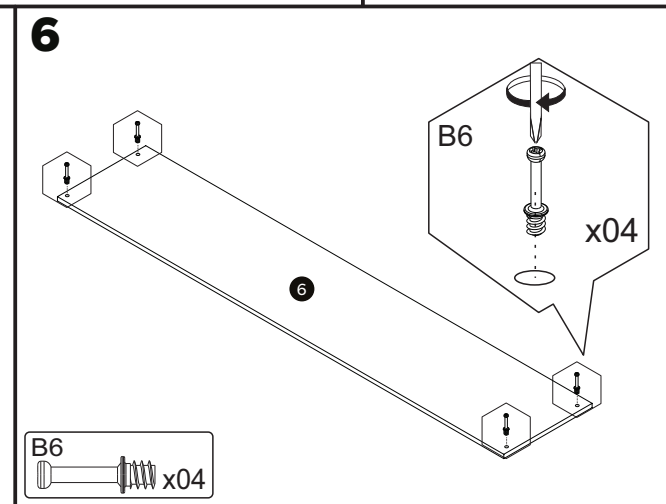
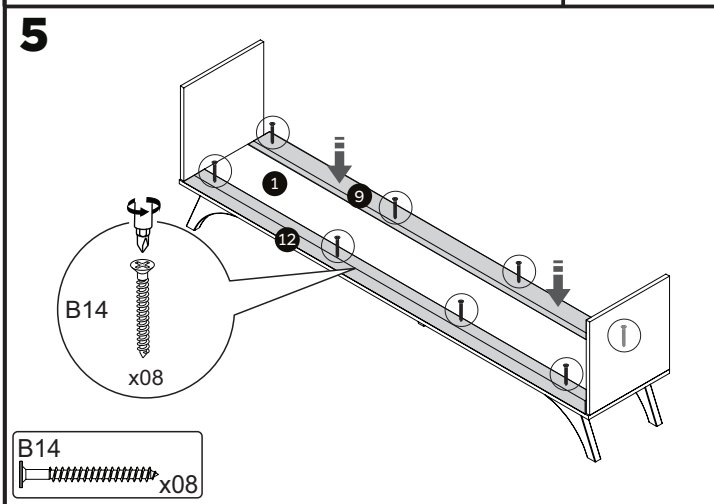
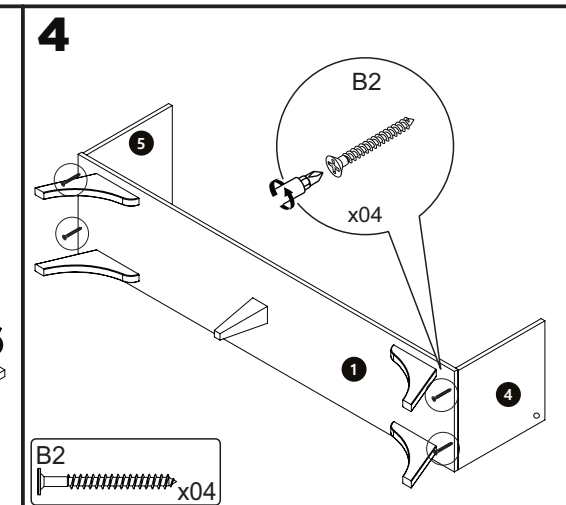
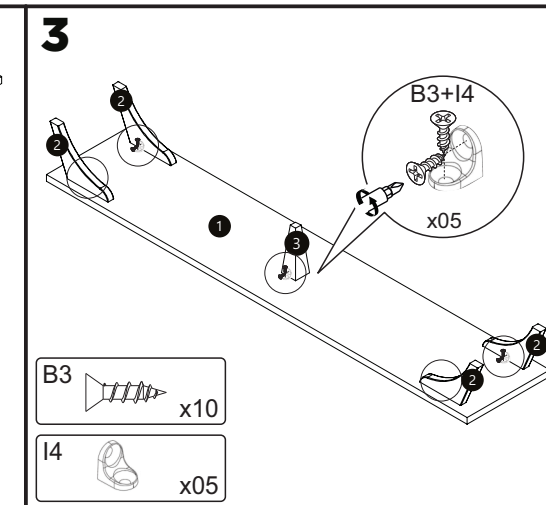
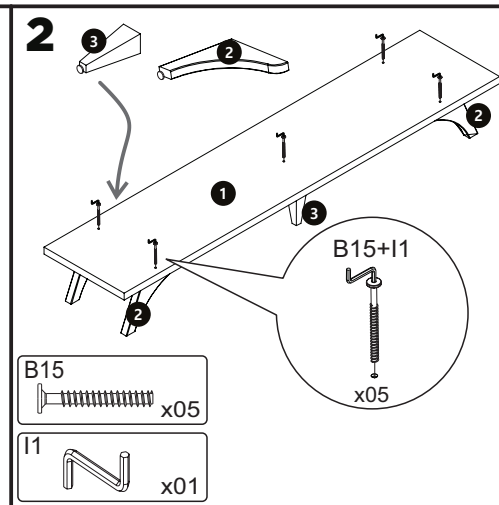
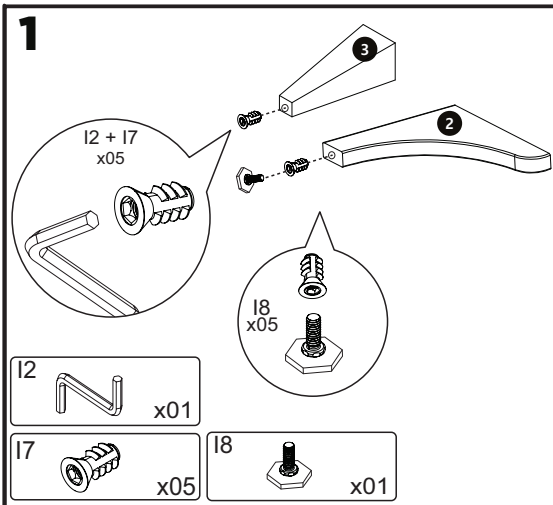

11 Encaixar a peça 10.
Fit part 10.
Monte la pieza 10.

12 Fixe a peça 10.
Attach part 10.
Adjunte la pieza 10.

B14
x04

13 Encaixar a peça 12.
Fit part 12.
Monte la pieza 12.

14 Fixe a peça 11.
Attach part 11.
Adjunte la pieza 11.

B14
x04

15 Nesta etapa:
1 - cole a fita de LED;
2 - encaixe o perfil difusor;
3 - encaixe o botão na lateral;
4 - passe todas as fiações necessárias.

In this step:
1 - stick the LED strip;
2 - fit the diffuser profile;
3 - fit the button on the side;
4 - pass all the necessary wiring.

En este paso:
1 - pegue la tira de LED;
2 - montar el perfil difusor;
3 - coloque el botón en el costado;
4 - pasar todo el cableado necesario.

KIT LED

Passar o fio do botão por este furo.
Insert the button string through this hole.
Inserte la cuerda del botón a través de este agujero.

16 Após instalar a fita de Led.
Encaixar o perfil de acabamento do LED.
After installing the LED strip.
Fit the LED finishing profile.
Después de instalar la tira de LED.
Montar el perfil de acabado LED.

H2
x01

17

Abaixe a alça preta e retire a peça J1 conforme abaixo.
Push the black pin down to remove the J1 part.
Empujar para abajo la pieza negra para retirar la parte J1.

J1
x02

18

B16+J1 x02

B16
x12

J1
x02

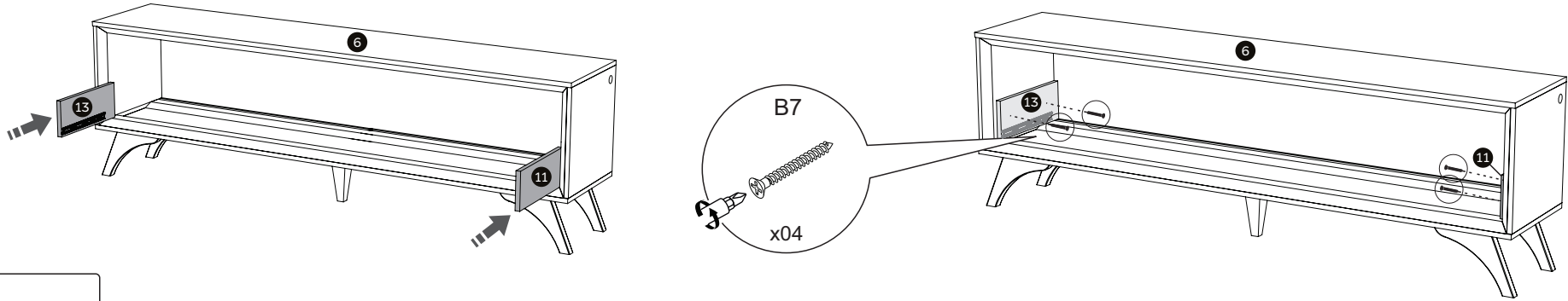
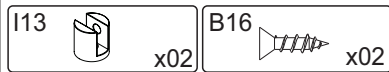
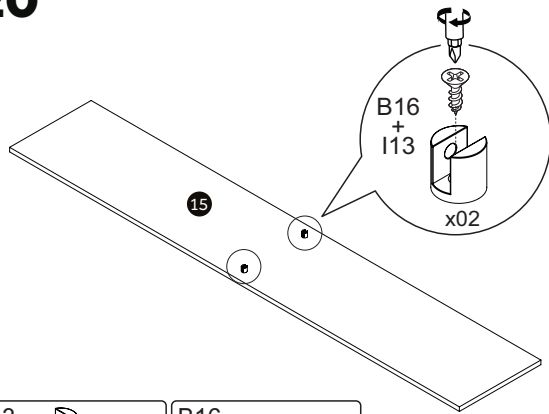
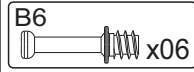
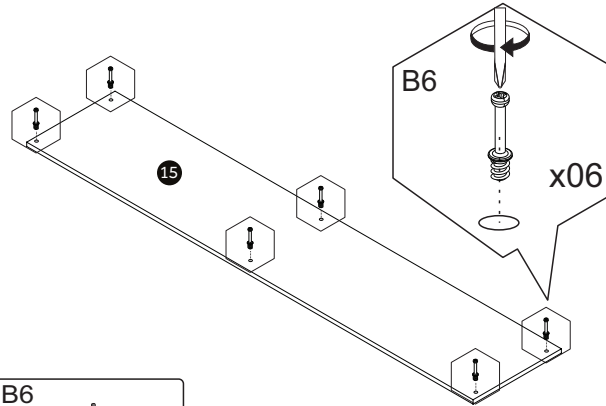
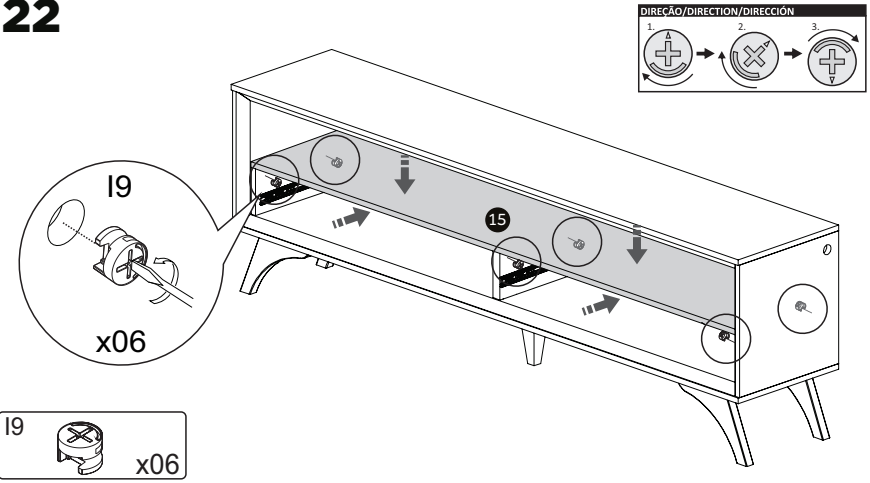
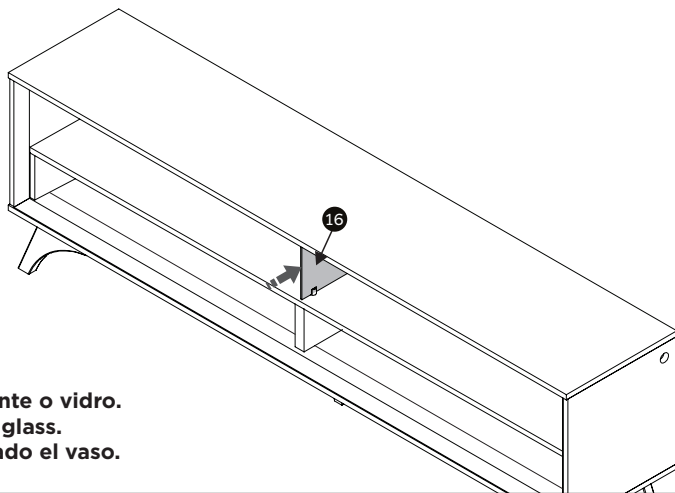
19**20****21****22****23**

Insira cuidadosamente o vidro.
Carefully insert the glass.
Introduce con cuidado el vaso.

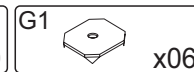
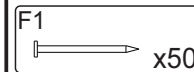
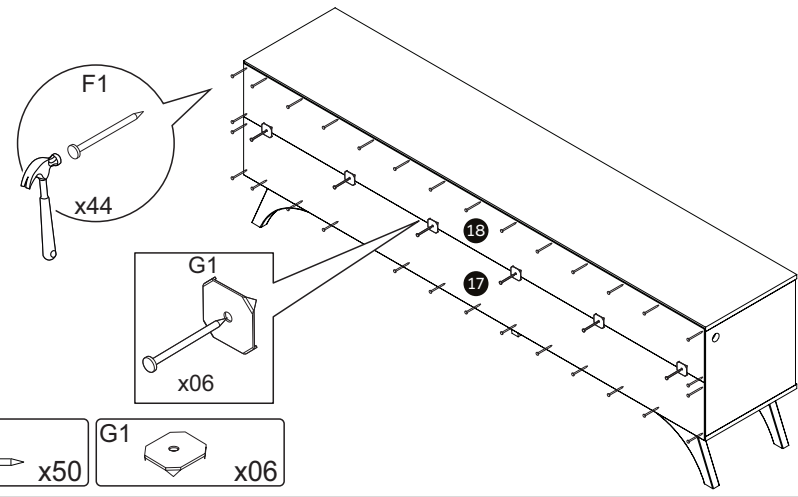
24

25

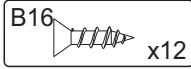
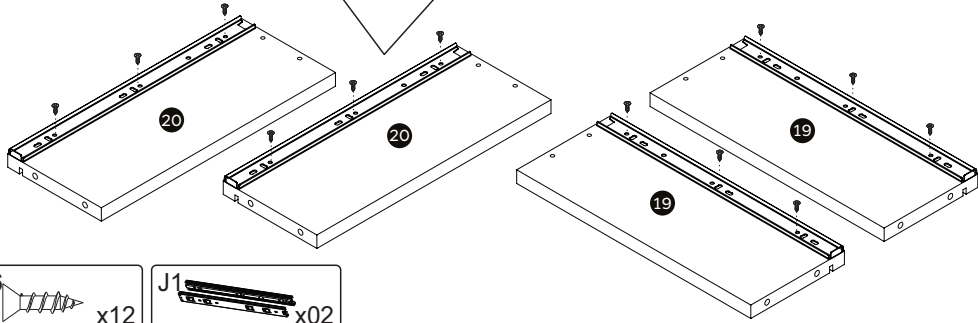
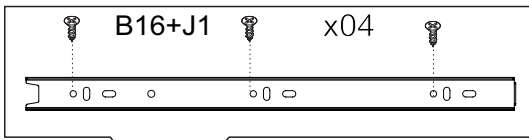

26

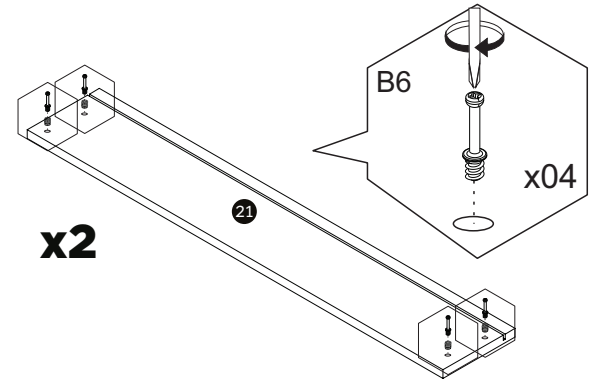

x2

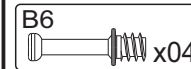

27

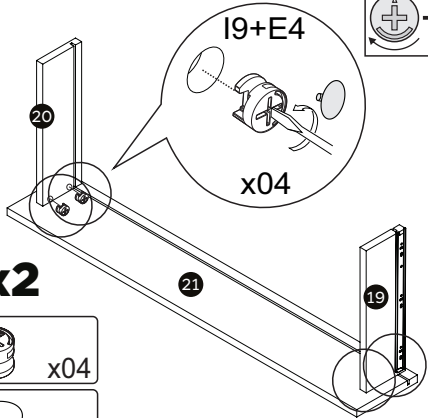

x2



28

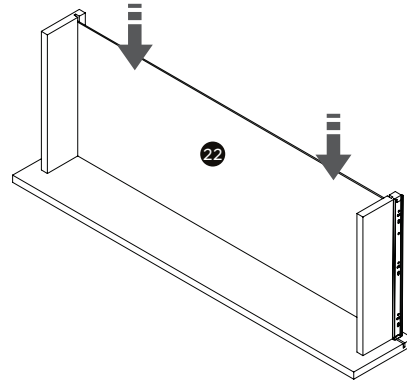

x2

29

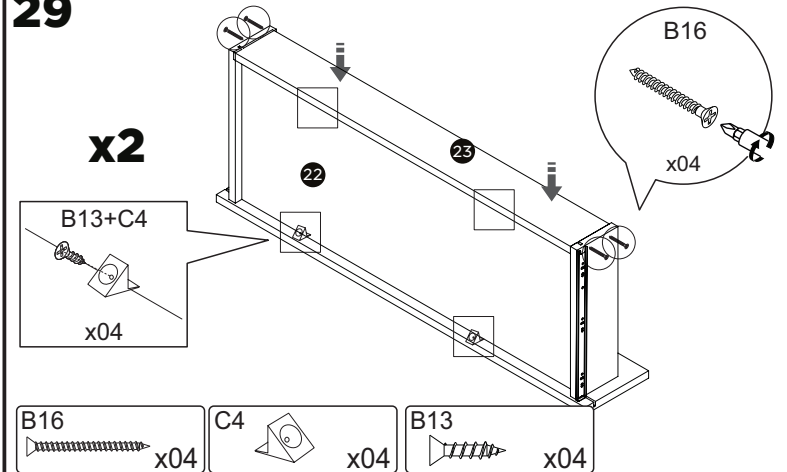

x2

30

