

YOU WILL NEED

TU AURAS BESOIN DE | NECESITARÁ | VOCÊ VAI PRECISAR

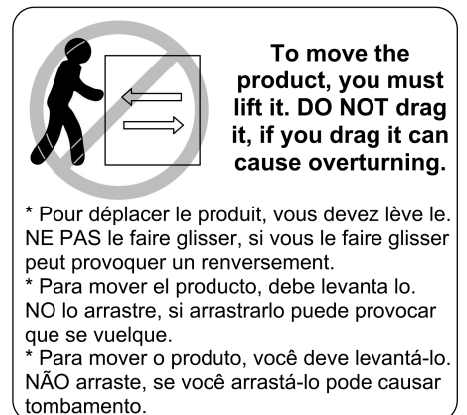

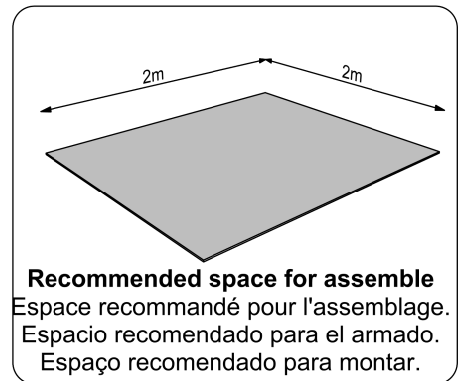

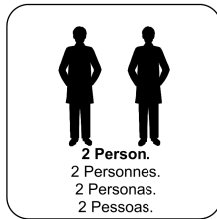
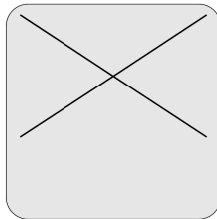
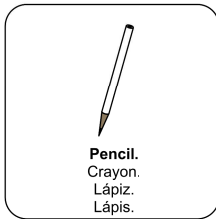
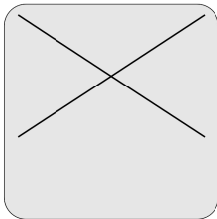
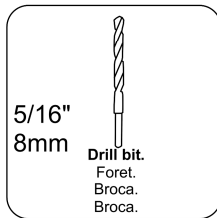
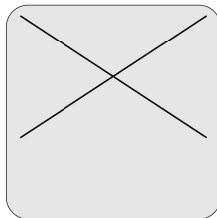
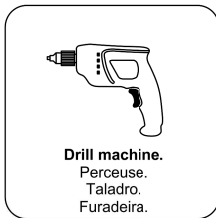
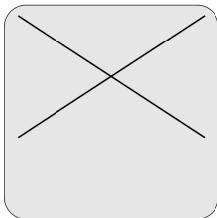
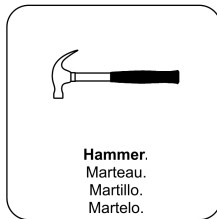
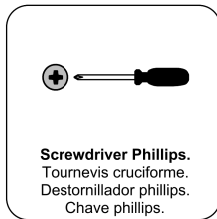
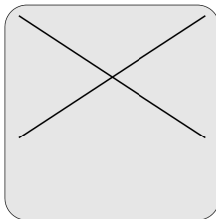
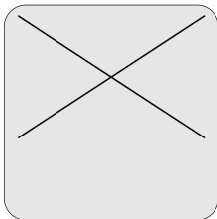





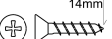

Tools not included

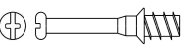
Outils non inclus | Herramientas no incluidas | Ferramentas não inclusas

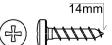
ACCESSORIES IDENTIFICATION

IDENTIFICATION DES ACCESSOIRES | IDENTIFICACIÓN DE ACCESORIOS
IDENTIFICAÇÃO DOS ACESSÓRIOS

| | | |
|---|--|------------------------|
| A |  | Qty./Qtd. 20 |
| Wooden dowel / Chevilles en bois / Taquete / Cavilha | | |
| AA |  | Qty./Qtd. 4 |
| Metal hinge super high / Charnière super haute / Bisagra alta / Dobradiça Alta | | |
| AR |  | Qty./Qtd. 12 |
| Flat head screw / Vis plate / Tornillo de cabeza plana / Parafuso cabeça chata | | |
| C |  | Qty./Qtd. 2 |
| Structural screw / Vis à tête structurelle / Tornillo estructural / Parafuso Estrutural | | |
| G |  | Qty./Qtd. 24 |
| Simple minifix screw / Vis minifix simple / Tornillo minifix simple / Haste Minifix Simples | | |
| H |  | Qty./Qtd. 24 |
| Drum lock / Verrouillage du tambour / Tambor minifix / Tambor de Minifix | | |
| J |  | Qty./Qtd. 28 |
| Nail / Ongle / Clavo / Prego | | |
| N |  | Qty./Qtd. 20 |
| Pan head screw / Vis à tête bombée / Tornillo de pan / Parafuso Panela | | |
| S |  | Qty./Qtd. 6 |
| Bushing / Douille expansive / Tapón / Bucha Plástica | | |
| T |  | Qty./Qtd. 6 |
| Flanged head screw / Vis à tête bride / Tornillo de cabeza flangeada / Parafuso flangeado | | |
| R |  | Qty./Qtd. 2 |
| Metalic bracke: / Support métallique / Soporte de metal / Suporte de Metal | | |

PARTS IDENTIFICATION

IDENTIFICATION DES PIÈCES | IDENTIFICACIÓN DE PIEZAS | IDENTIFICAÇÃO DAS PEÇAS

| | | |
|-----------|--|------------------------|
| 01 | Base Base Base Base | Qty./Qtd. 02 |
| 02 | Center Shelf Étagère Centrale Repisa Central Prateleira Central | Qty./Qtd. 01 |
| 03 | Shelf Étagère Repisa Prateleira | Qty./Qtd. 04 |
| 04 | Left Side Côté Gauche Lateral Izquierdo Lateral Esquerda | Qty./Qtd. 01 |
| 05 | Right Side Côté Droite Lateral Derecho Lateral Direita | Qty./Qtd. 01 |
| 06 | Tray Plateau Traviesa Travessa | Qty./Qtd. 02 |
| 07 | Door Porte Puerta Porta | Qty./Qtd. 01 |
| 08 | Backboard Panneau Fondo Trasero Costa | Qty./Qtd. 01 |

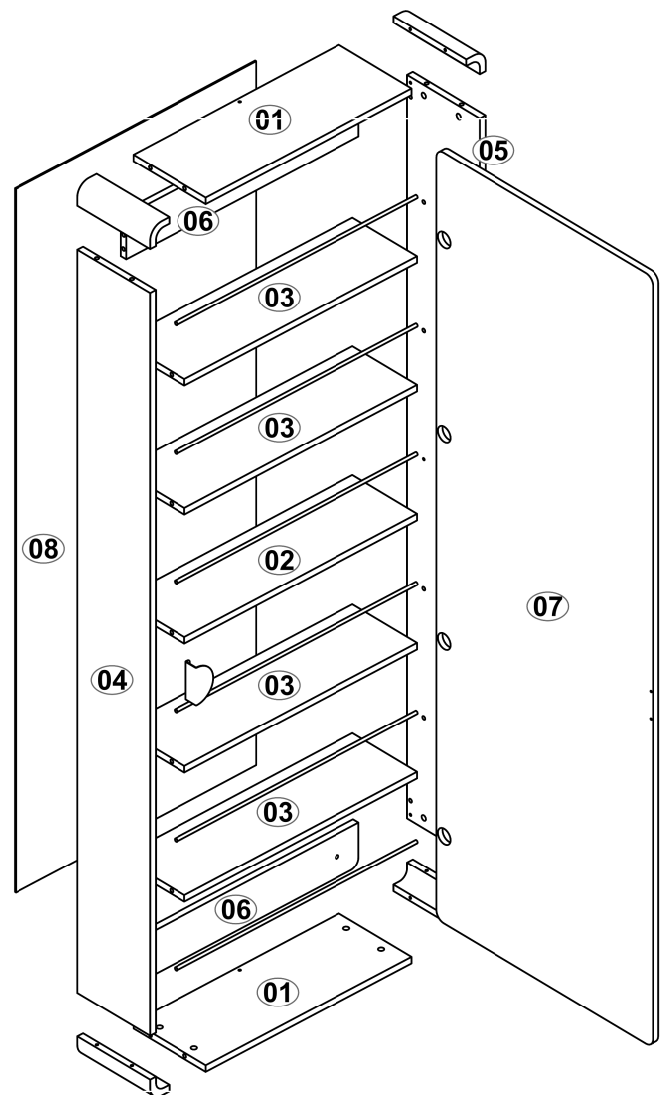

PRE-ASSEMBLY - PRÉ-ASSEMBLAGE - PRE-ARMADO
PRÉ-MONTAGEM

01 -

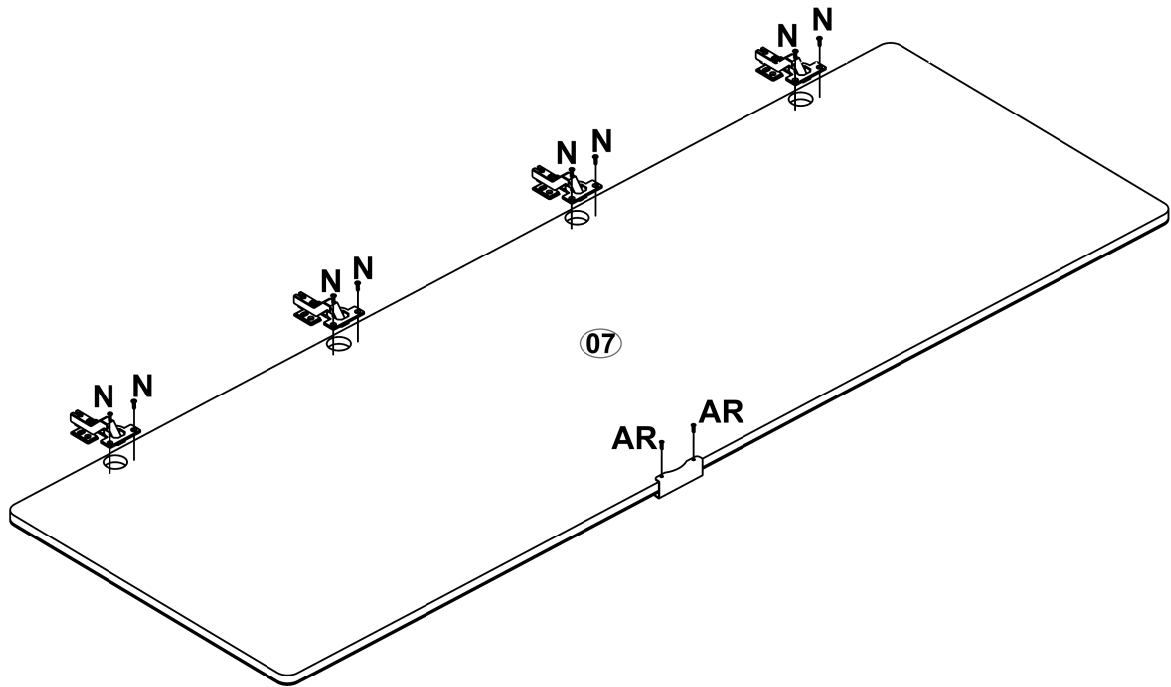

02 -

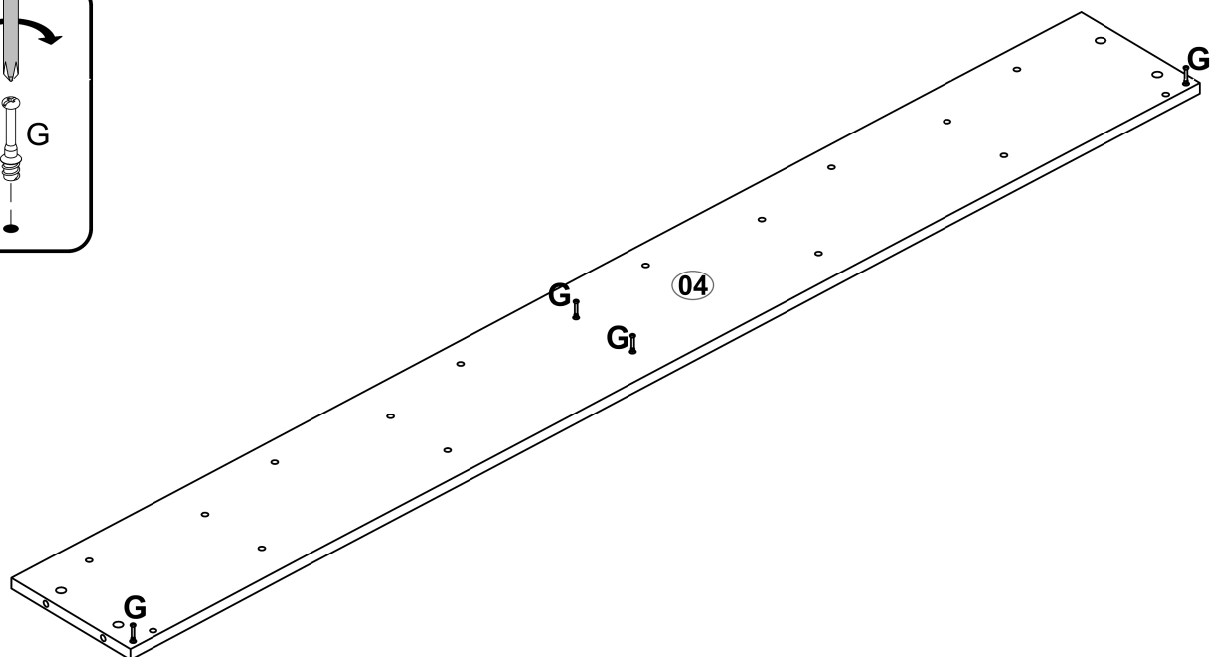
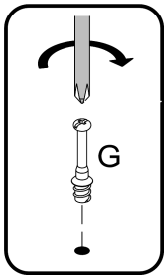

03 -

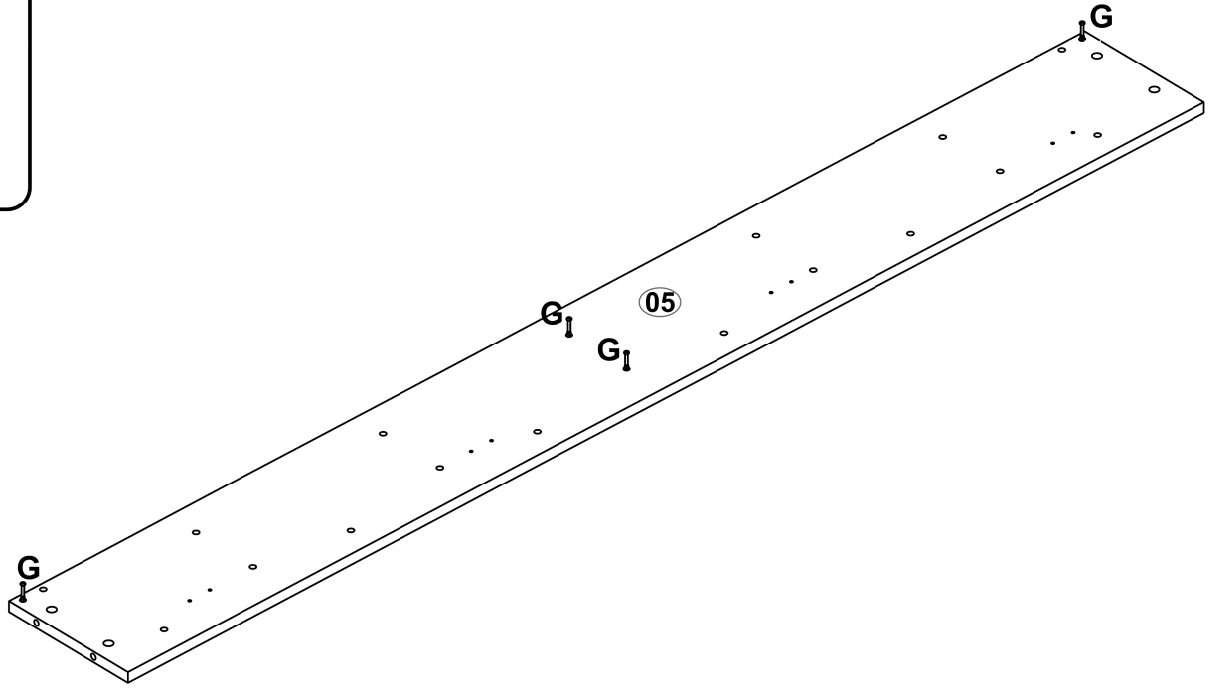
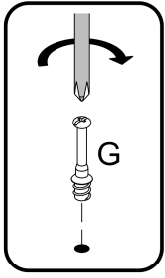

04 -

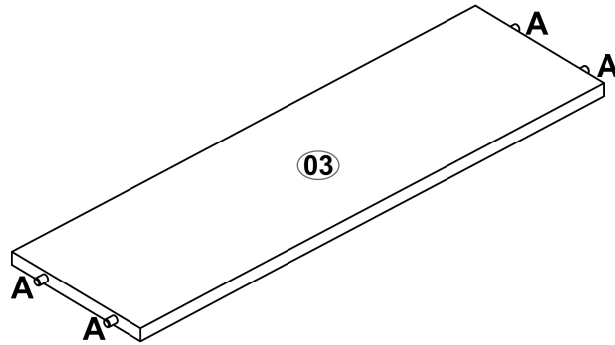
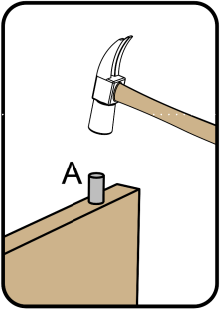

05 -

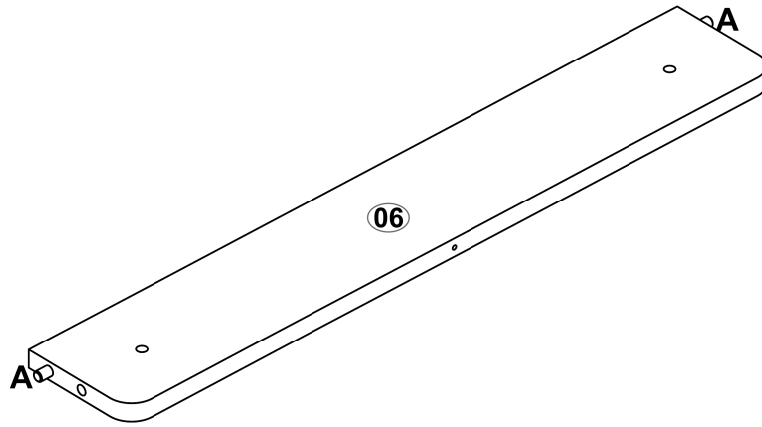
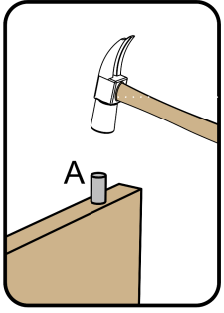

06 -

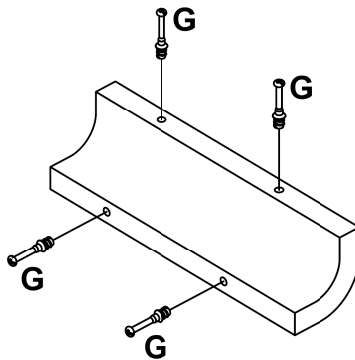
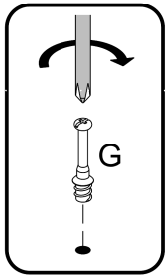

ASSEMBLY - MONTAGE - ARMADO - MONTAGEM

07 -

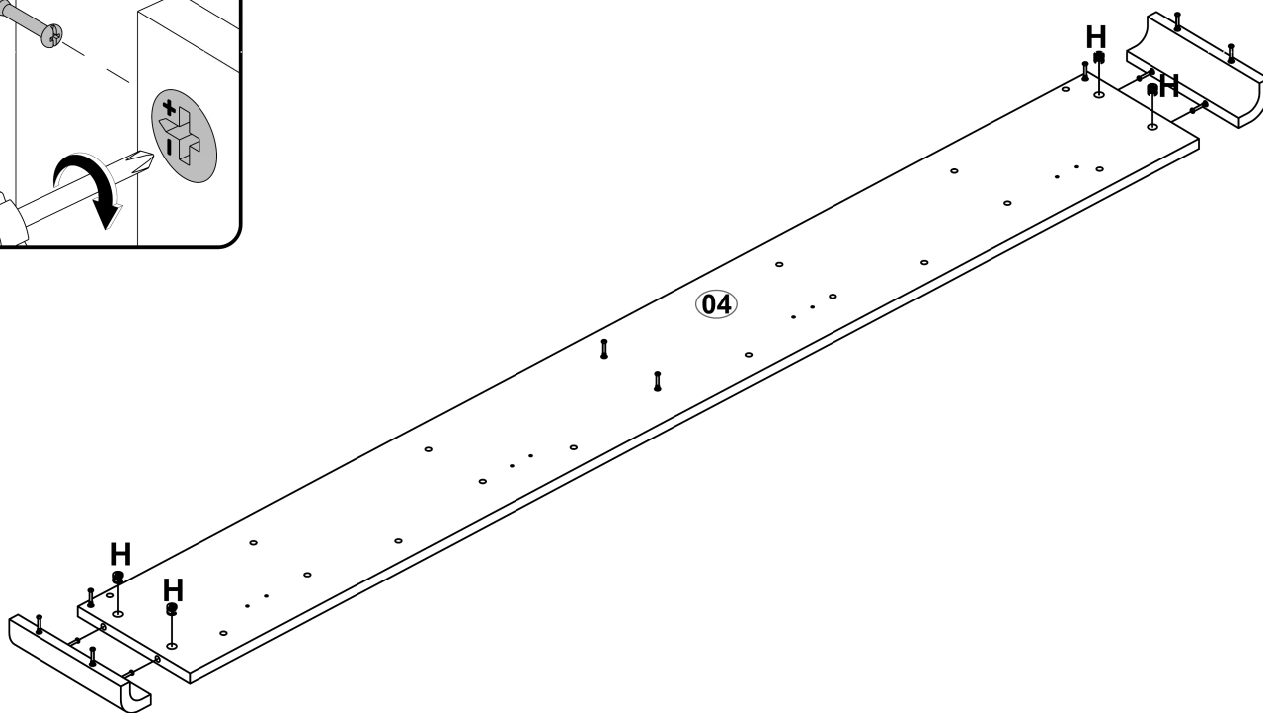
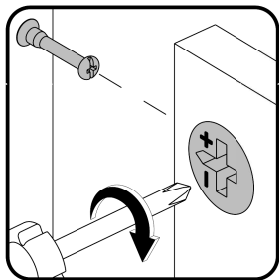

08 -

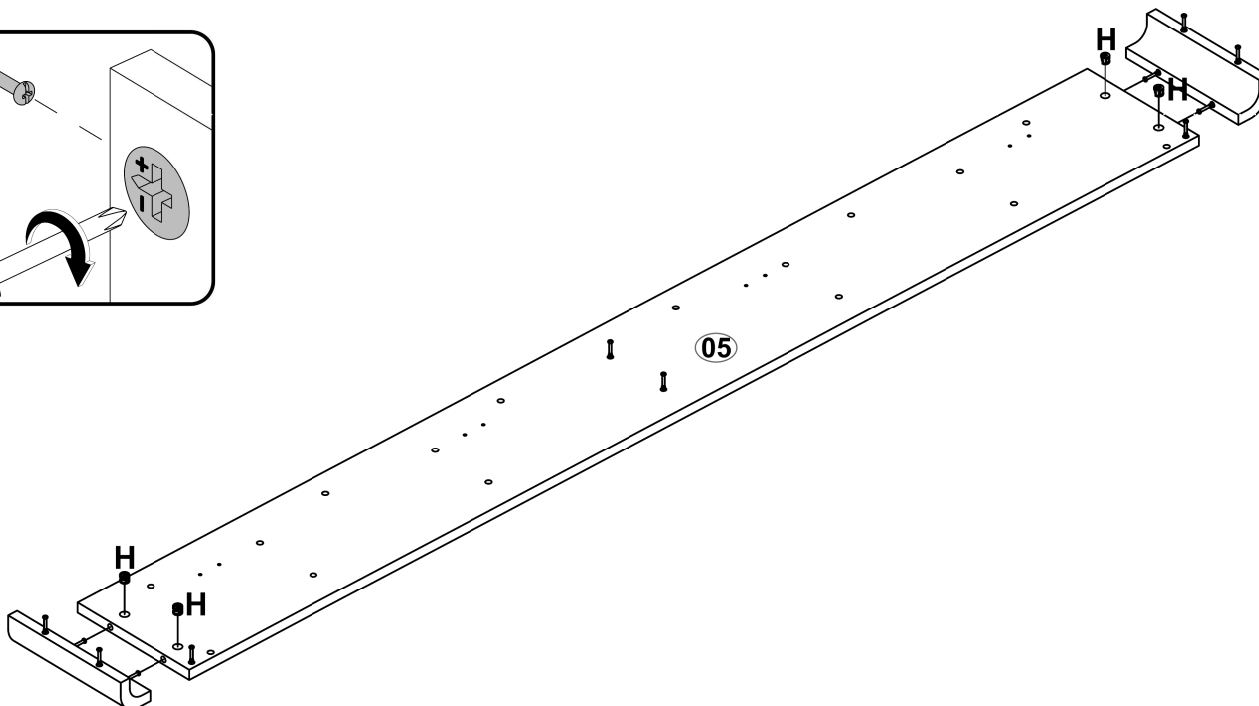
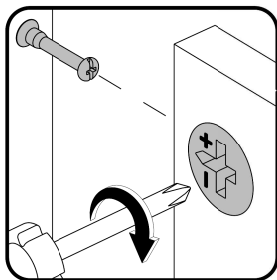

09 -

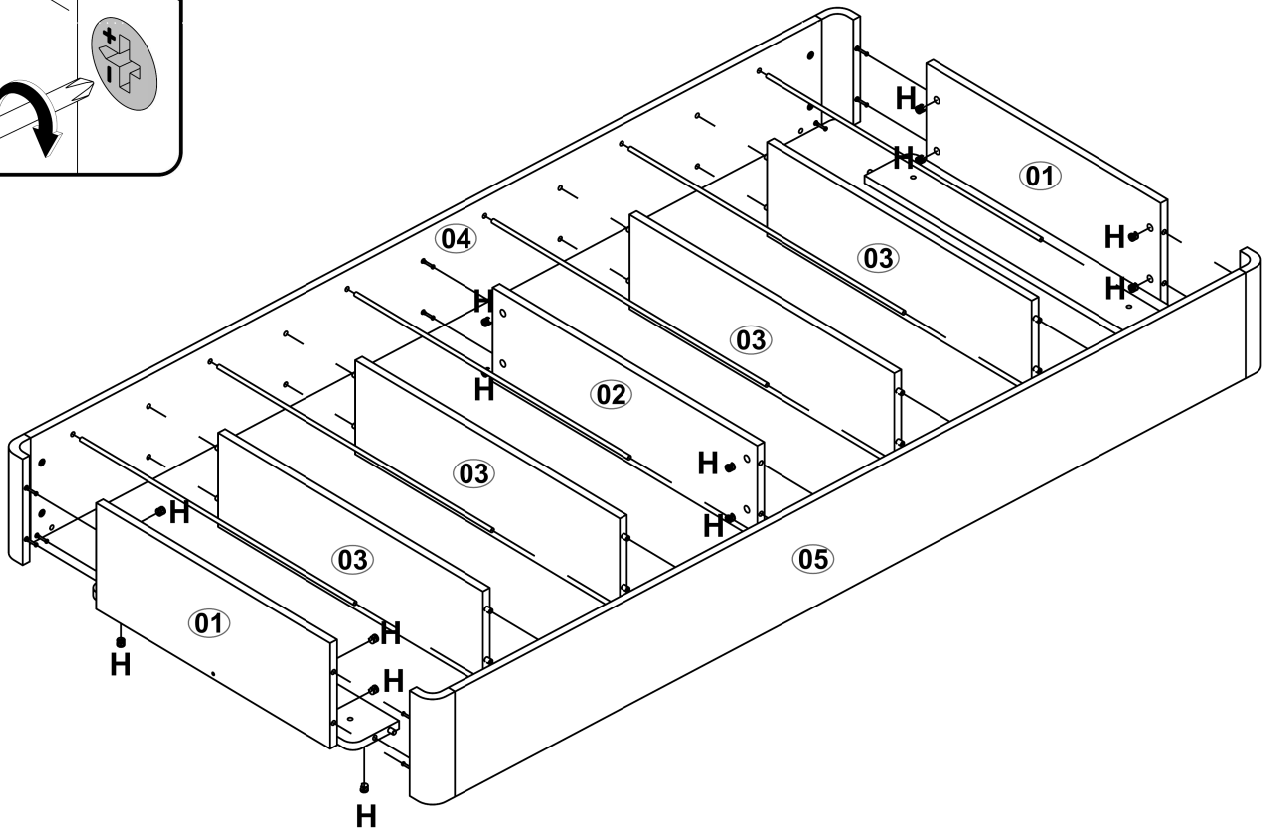
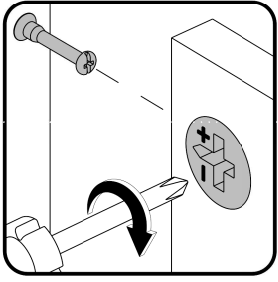

10 -

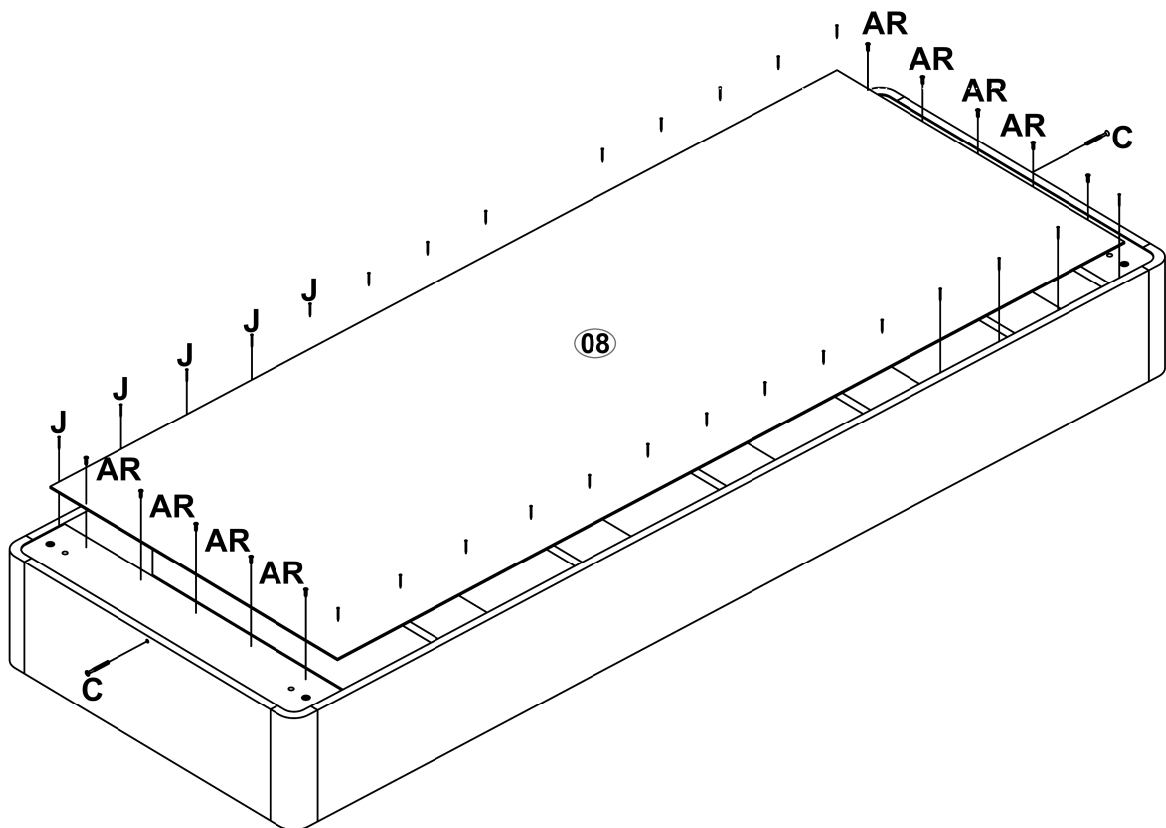

11 -

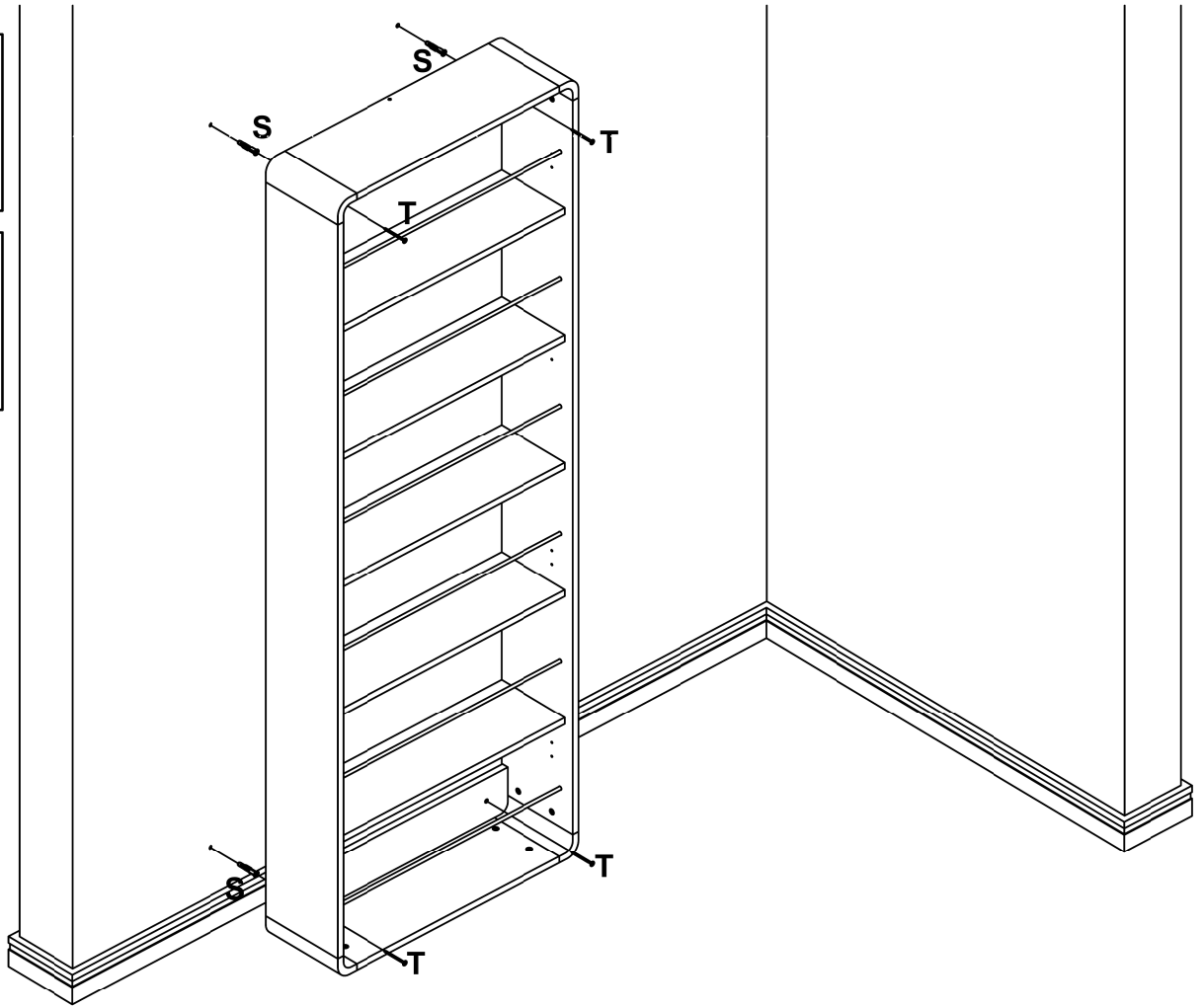
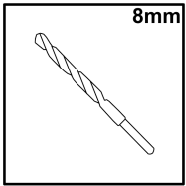
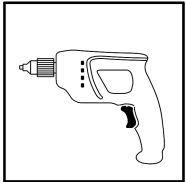

12 -

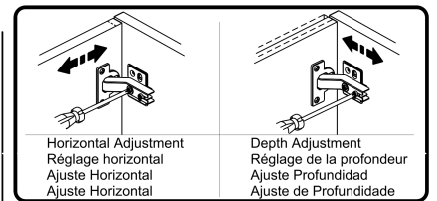
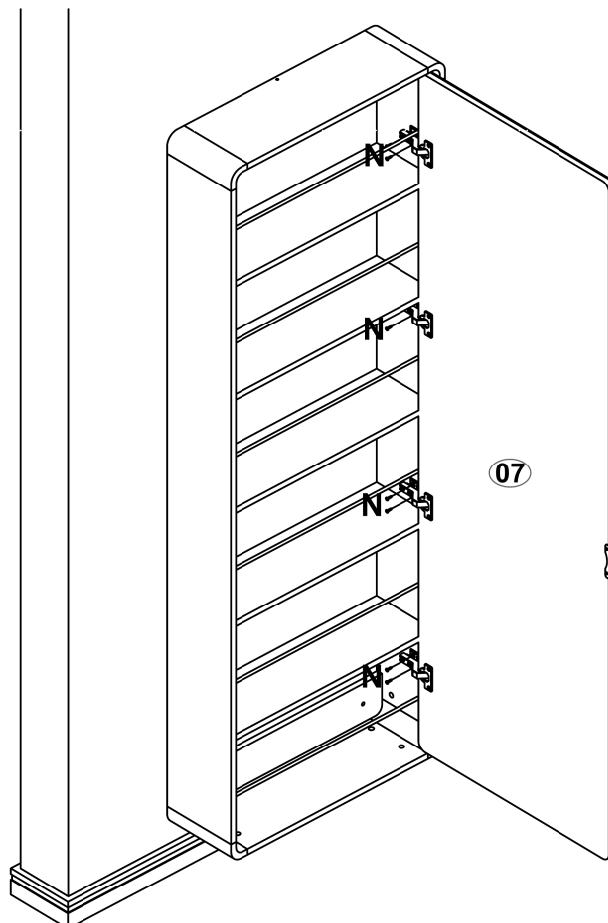

***Note:** Use the stickers and caps to finish.
***Remarque:** Utiliser les autocollants et les capuchons pour terminer la finition.
***Nota:** Utilice los adhesivos y tapas para finalizar el acabado.
***Nota:** Utilize os adesivos e tampas para finalizar o acabamento.