

ASSEMBLY INSTRUCTIONS MANUAL DE MONTAGEM / INSTRUCCIONES DE ARMADO

MADISON DRESSER 6 DRAWERS
CÔMODA MADISON 6 GAVETAS
CÓMODA MADISON 2 CAJONES

Reference 200380 | Revisão 01
Referência 200380 | Revisão 01
Referencia 200380 | Revisión 01

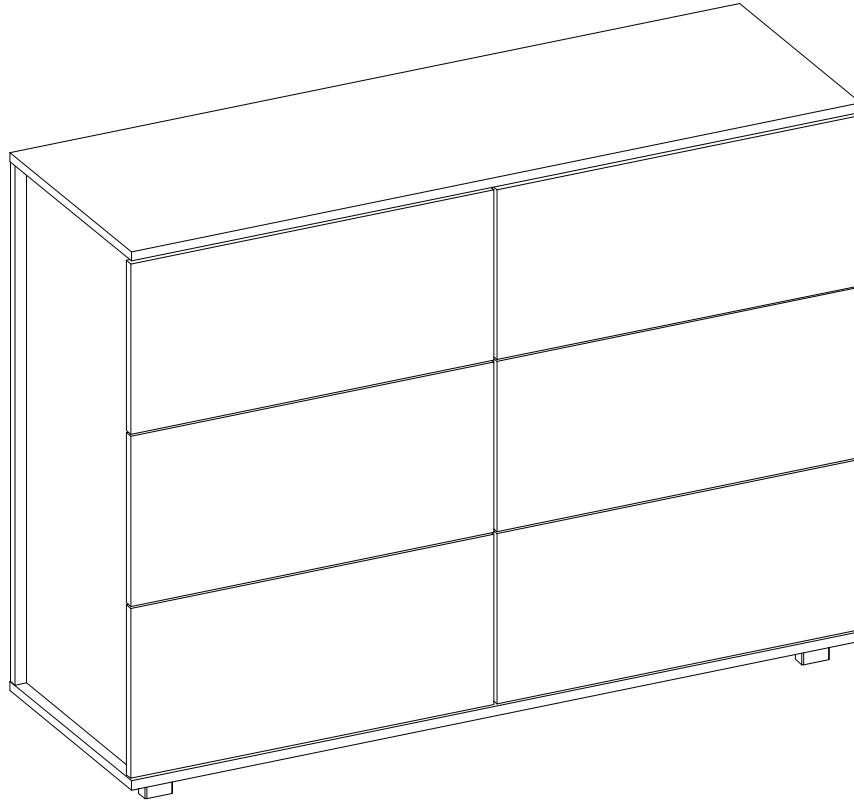

YOU WILL NEED / VOCÊ VAI PRECISAR DE / USTED NECESITARÁ

Tools not supplied / Ferramentas não fornecidas / Herramientas no incluidas

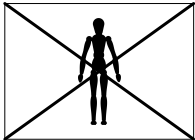

1 Person
1 Pessoa
1 Persona

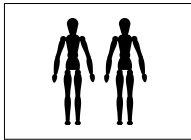

2 People
2 Pessoas
2 Personas

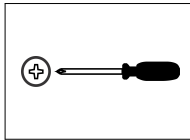

Screwdriver Phillips
Chave Phillips
Destornillador cruz

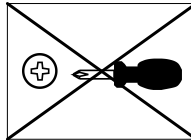

Small screwdriver Philips
Chave Phillips menor
Destornillador cruz menor

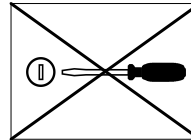

Screwdriver slotted
Chave fenda
Destornillador plano

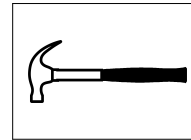

Hammer
Martelo
Martillo

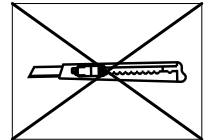

Stylet
Estilete
Estilete

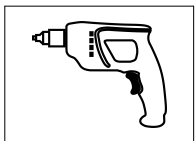

Drill machine
Furadeira
Taladro

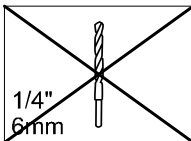

Drill bit
Broca
Taladro

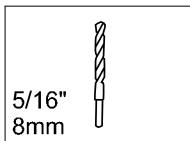

Drill bit
Broca
Taladro

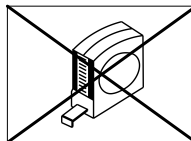

Measuring tape
Trena
Cinta de medición

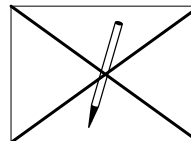

Pencil
Lápis
Lápis

NOTES: The separation of the accessories before you start the assembly will facilitate the same. In case of doubt on the size of the screws and bolts, use the ruler to bottom of page 3.

NOTAS: A separação dos acessórios antes de iniciar a montagem facilitará a mesma. Em caso de dúvida no tamanho dos parafusos e cavilhas, utilize a régua ao final da página 3.

NOTAS: La separación de los accesorios antes de comenzar el armado facilitará el mismo. En caso de duda sobre el tamaño de los tornillos y taquetes, utilice la regla al pie de página 3.

MAXIMUM RECOMMENDED WEIGHT
BEING THIS EVENLY DISTRIBUTED

PESO MÁXIMO RECOMENDADO SENDO
ESTE DISTRIBUÍDO UNIFORMEMENTE

PESO MÁXIMO RECOMENDADO SIENDO
ESTE UNIFORMEMENTE DISTRIBUIDO

_	LB	KG
D	11	5
J	66	30

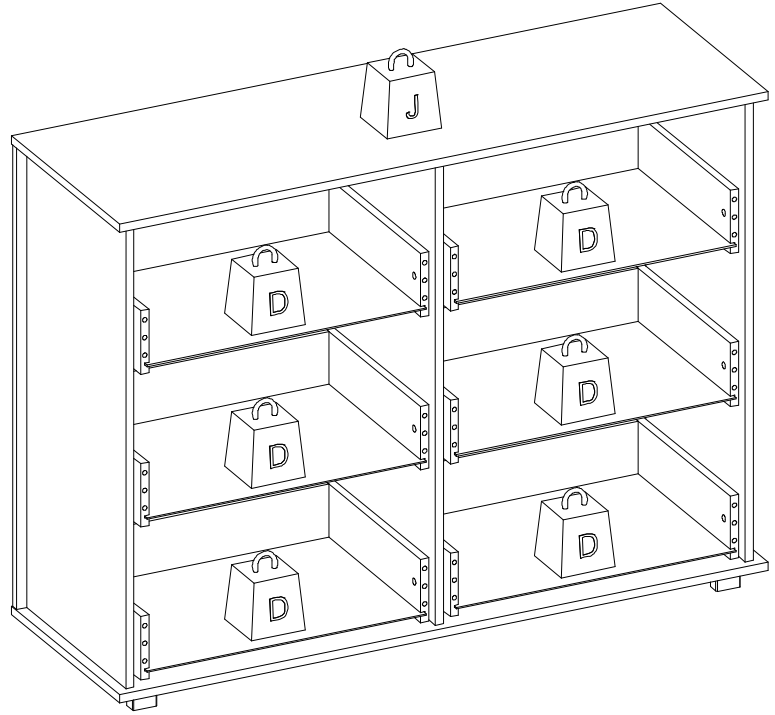





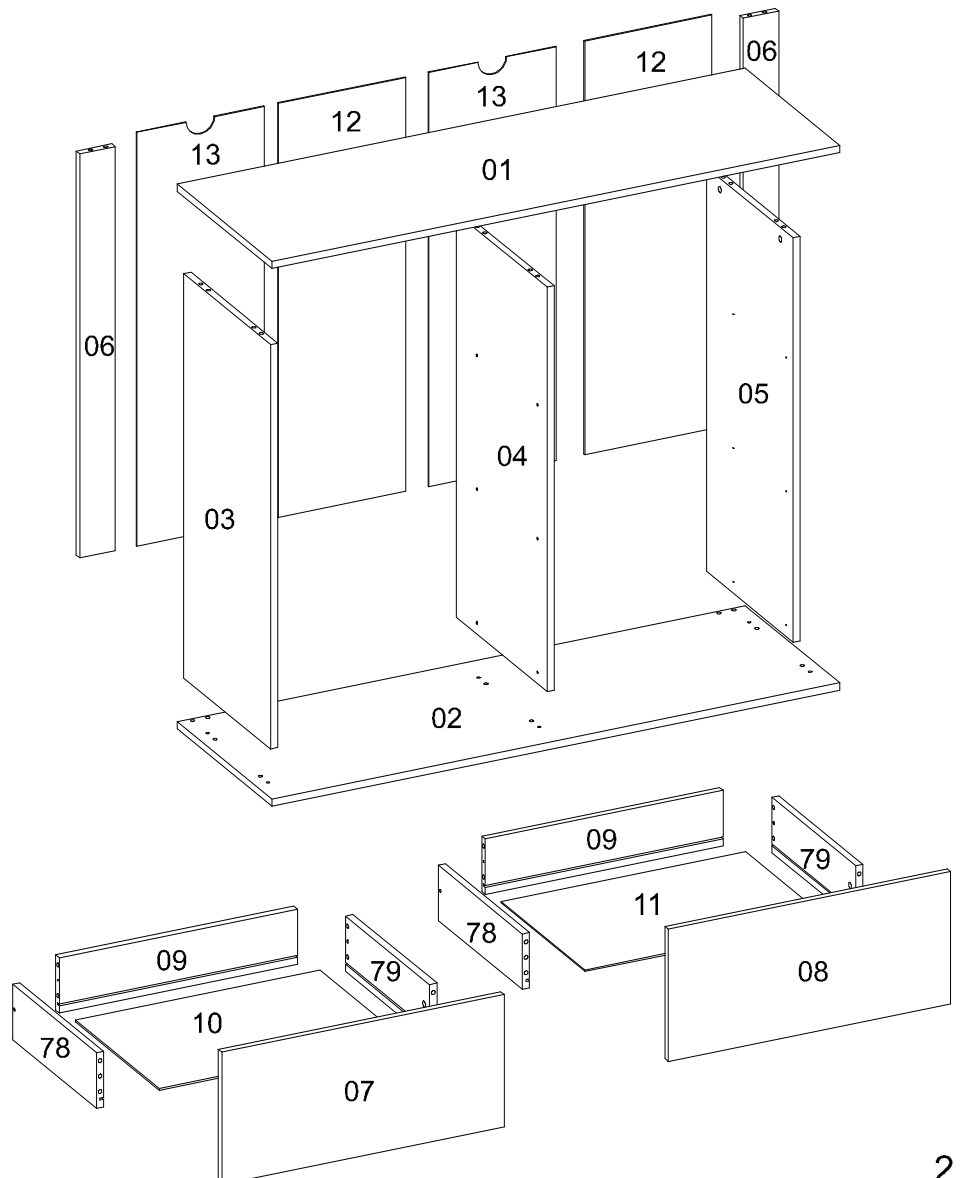



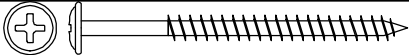

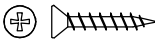



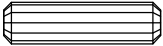

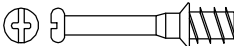
Nº	Measures_Inches	Medidas_cm	Qty./Qtd.
01	47 1/4 x 15 3/4 x 5/8	120.0 x 40.0 x 1.5	1
02	47 1/4 x 15 3/4 x 5/8	120.0 x 40.0 x 1.5	1
03	33 x 14 1/2 x 5/8	83.7 x 36.7 x 1.5	1
04	33 x 15 1/8 x 5/8	83.7 x 38.3 x 1.5	1
05	33 x 14 1/2 x 5/8	83.7 x 36.7 x 1.5	1
06	33 x 3 x 5/8	83.7 x 7.5 x 1.5	2
07	23 1/2 x 10 3/4 x 5/8	59.7 x 27.4 x 1.5	3
08	23 1/2 x 10 3/4 x 5/8	59.7 x 27.4 x 1.5	3
09	19 3/4 x 4 1/2 x 5/8	50.3 x 11.5 x 1.5	6
10	20 3/8 x 13 7/8 x 1/8	51.7 x 35.4 x 0.3	1
11	20 3/8 x 13 7/8 x 1/8	51.7 x 35.4 x 0.3	5
12	33 3/4 x 10 5/8 x 1/8	85.7 x 26.9 x 0.3	2
13	33 3/4 x 10 5/8 x 1/8	85.7 x 26.9 x 0.3	2
78	14 x 4 1/2 x 5/8	35.5 x 11.5 x 1.5	6
79	14 x 4 1/2 x 5/8	35.5 x 11.5 x 1.5	6

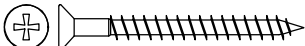
PARTS IDENTIFICATION IDENTIFICAÇÃO DAS PEÇAS / IDENTIFICACIÓN DE LAS PIEZAS

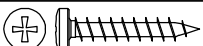
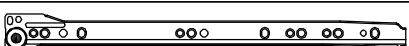
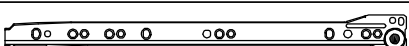
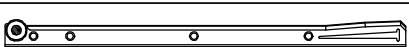
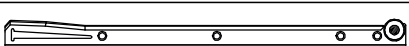

IDENTIFICATION OF ACCESSORIES IDENTIFICAÇÃO DOS ACESSÓRIOS/ IDENTIFICACIÓN DE ACCESORIOS

A		Flanged head screw / Parafuso flangeado / Tornillo de cabeza flangeada	5,0x60 mm	2
A1		Glue / Cola / Pegamento	13 g	1
A6		"H" profile / Perfil "H" / Perfil "H"	-	2
A8		Flat head screw / Parafuso chato / Tornillo de cabeza plana	3,5x20 mm	12
B3		Bushing / Bucha expansiva / Tapón	8x50 mm	2
C1		Metal claw / Garra de metal / Garra metal	-	5
C14		Foot / Sapata retangular / Pie	33x45 mm	5
E		Wooden dowel / Cavilha / Taquete	8x30 mm	68
E9		Strap / Cinta / Correa	-	2
J		Simple minifix screw / Haste minifix simples / Tornillo minifix simple	-	18
L		Drum lock / Tambor minifix / Tambor minifix	12 mm	18
M		Bore patch adhesive / Tapa furo adesivo / Tapones adhesivo	-	12
O		Flat head screw / Parafuso chato / Tornillo de cabeza plana	4,5x45 mm	18
o1		Triangular support / Suporte triangular / Soporte triangular	-	12
P5		Flat head screw / Parafuso chato especial / Tornillo de cabeza plana	3,5x14 mm	36
R		Flat head screw / Parafuso chato / Tornillo de cabeza plana	6,0x8 mm	12
S		Pan head screw / Parafuso panela / Tornillo de pan	3,5x14 mm	2
S18		Pan head screw / Parafuso panela / Tornillo de pan	3,5x25 mm	10
VA		Metallic slide the left field / Corrediça lateral esquerda / Corredera lateral izquierda	350 mm	6
VB		Metallic slide the right field / Corrediça lateral direita / Corredera lateral derecha	350 mm	6
VC		Drawer slide left / Corrediça gaveta esquerda / Corredera izquierda cajón	350 mm	6
VD		Drawer slide right / Corrediça gaveta direita / Corredera derecha cajón	350 mm	6
X6		Nail / Prego / Clavo	10 x 7	51



PRE-ASSEMBLE
PRÉ-MONTAGE / PRE ARMADO

01

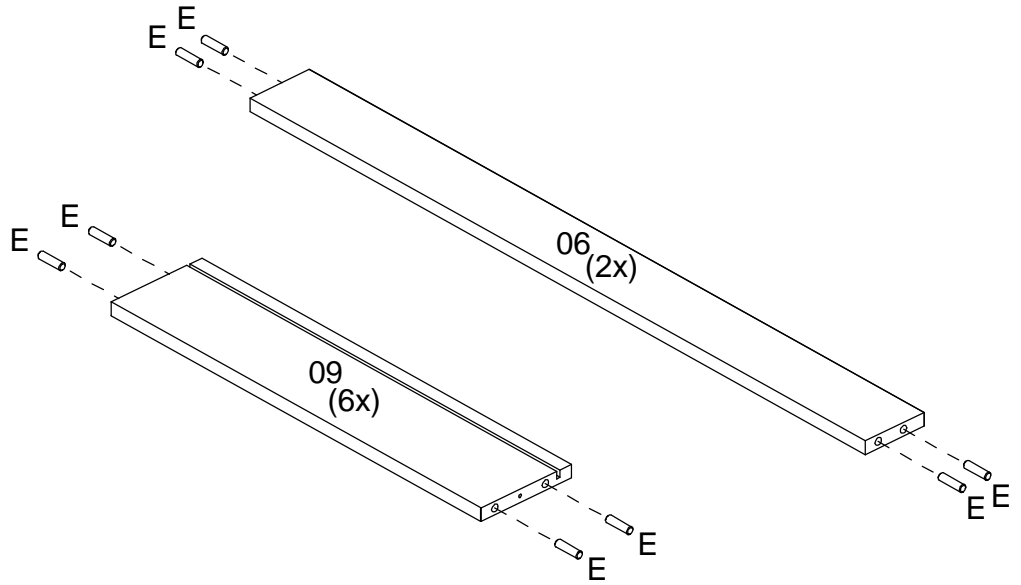
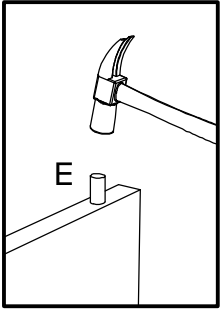

02

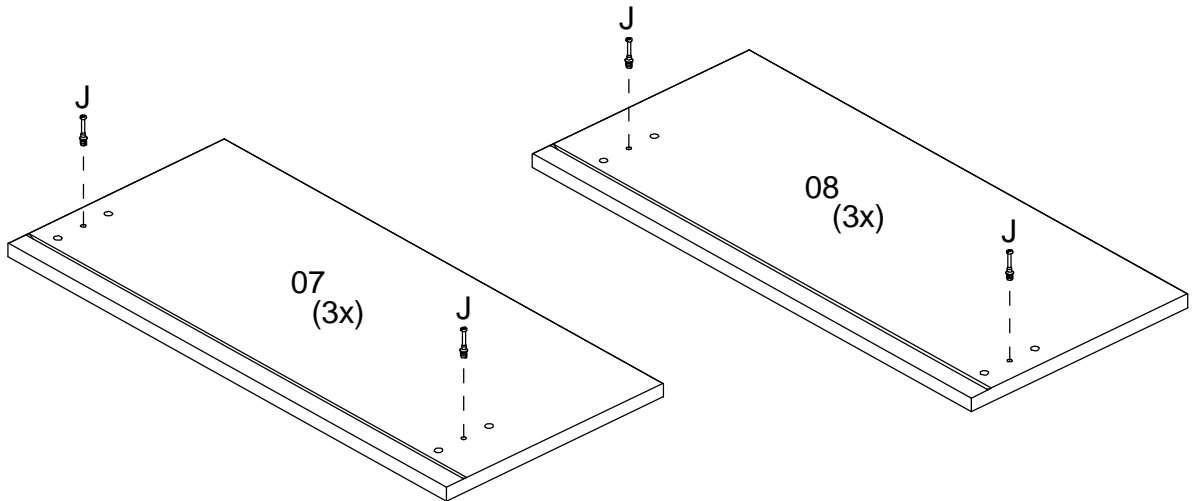
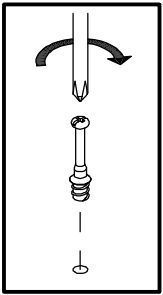

03

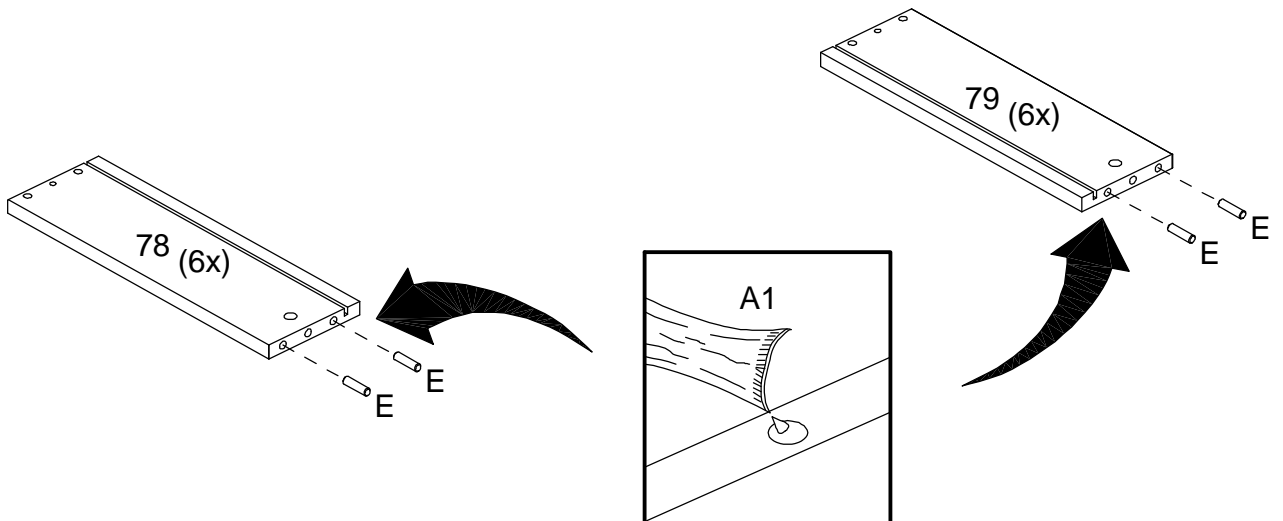

04

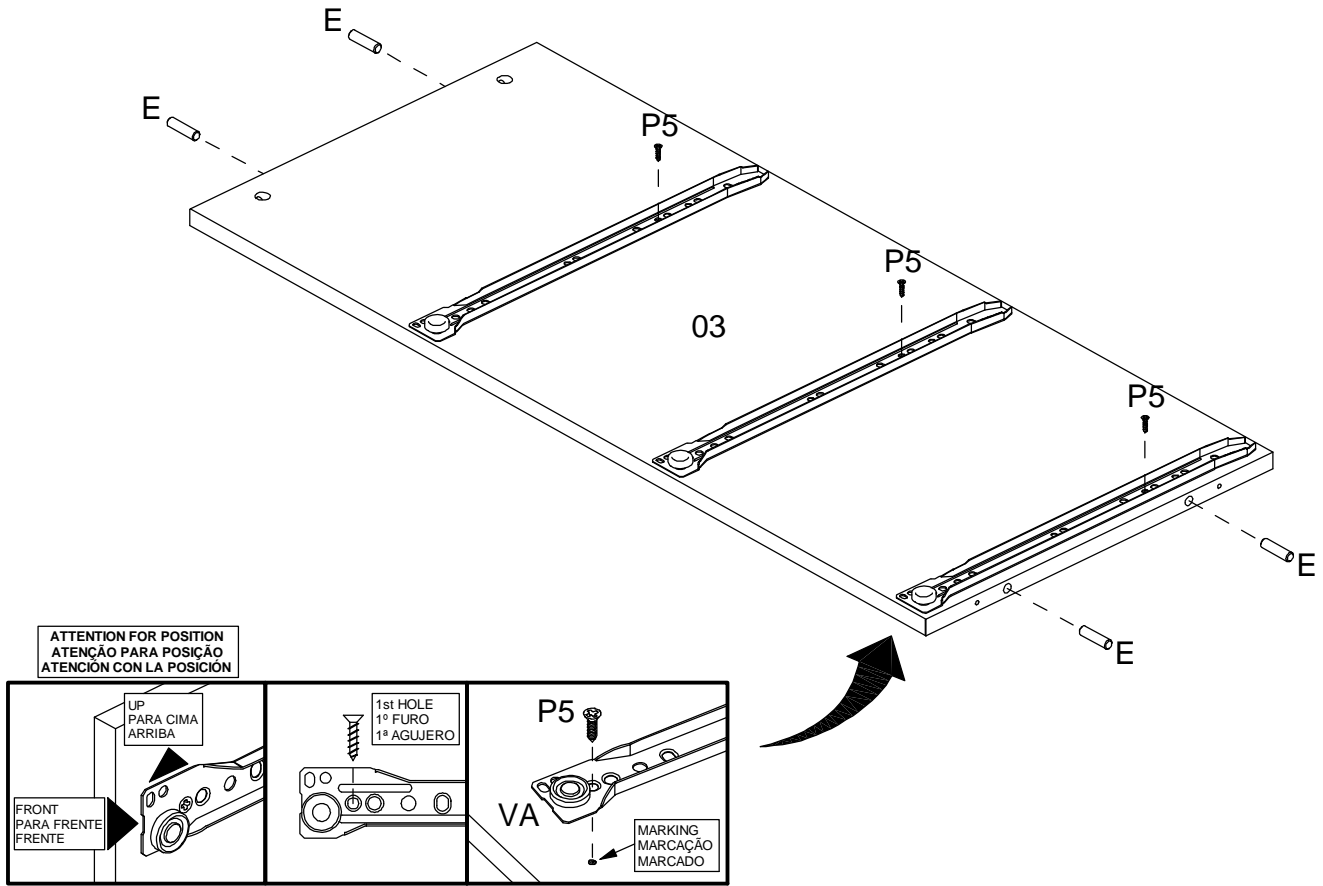

05

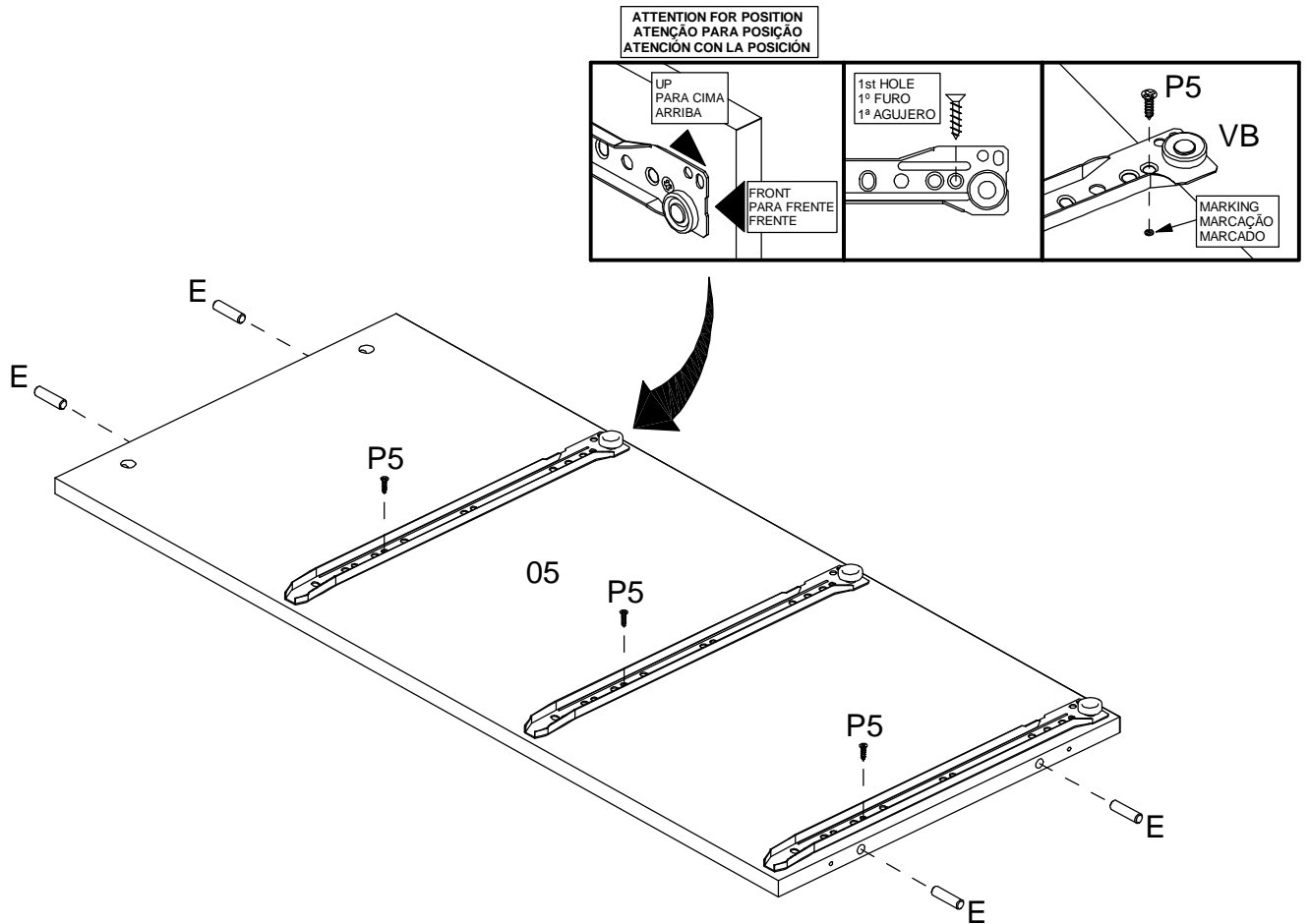

06

ATTENTION FOR POSITION
ATENÇÃO PARA POSIÇÃO
ATENCIÓN CON LA POSIÇÃO

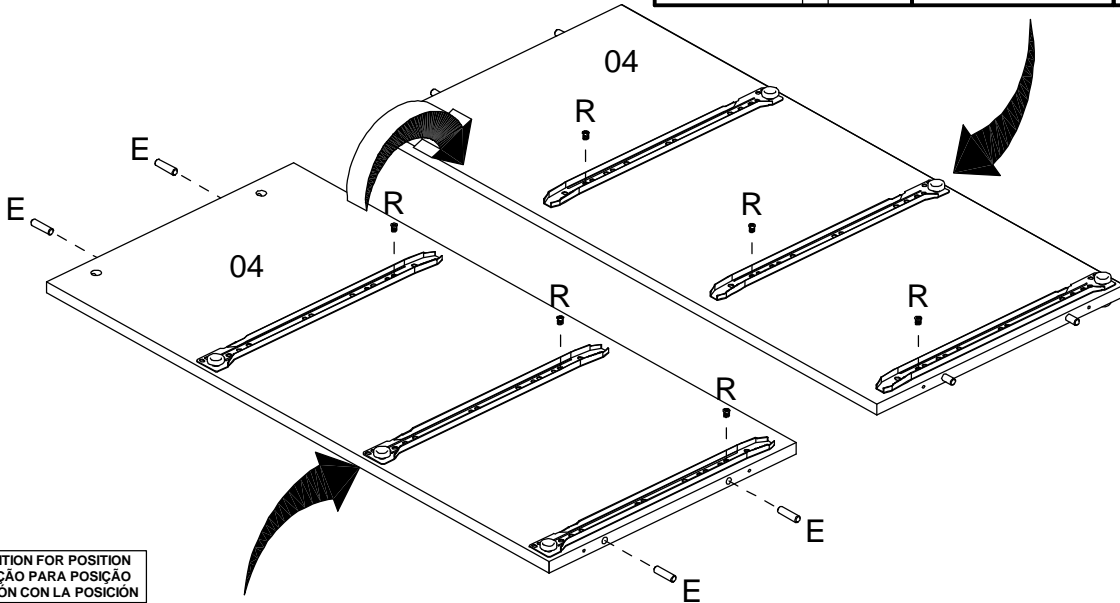
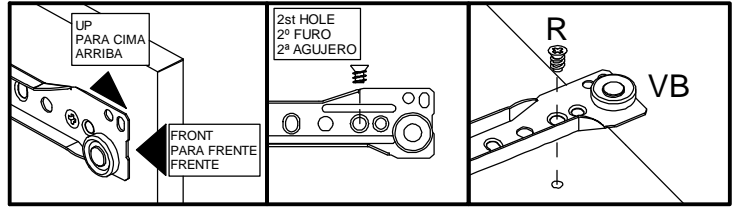

ATTENTION FOR POSITION
ATENÇÃO PARA POSIÇÃO
ATENCIÓN CON LA POSIÇÃO



07

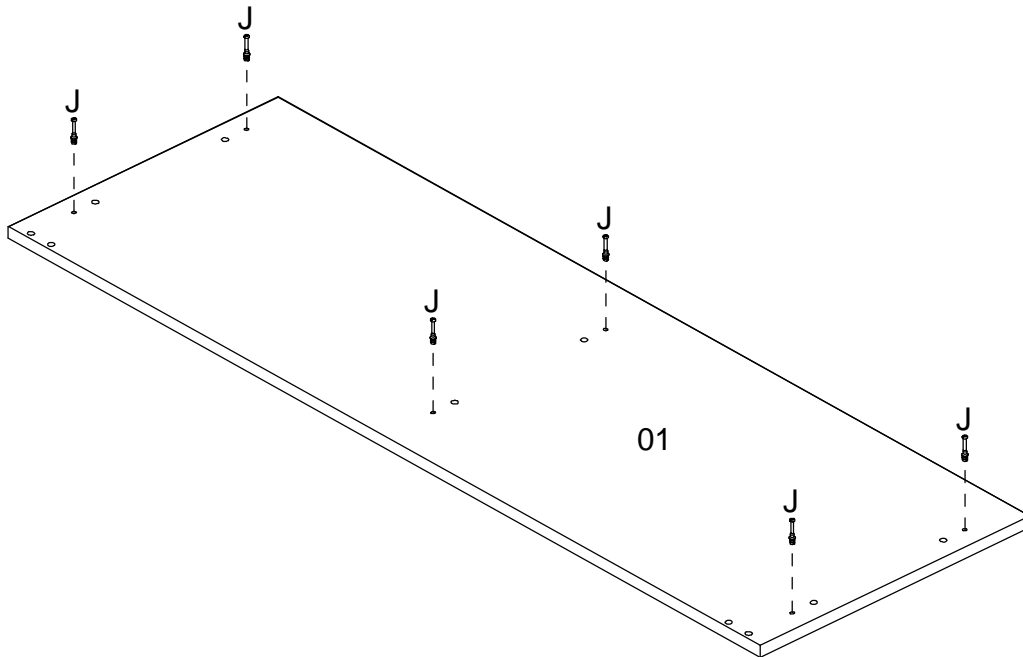

ASSEMBLY
MONTAGEM / ARMADO

08

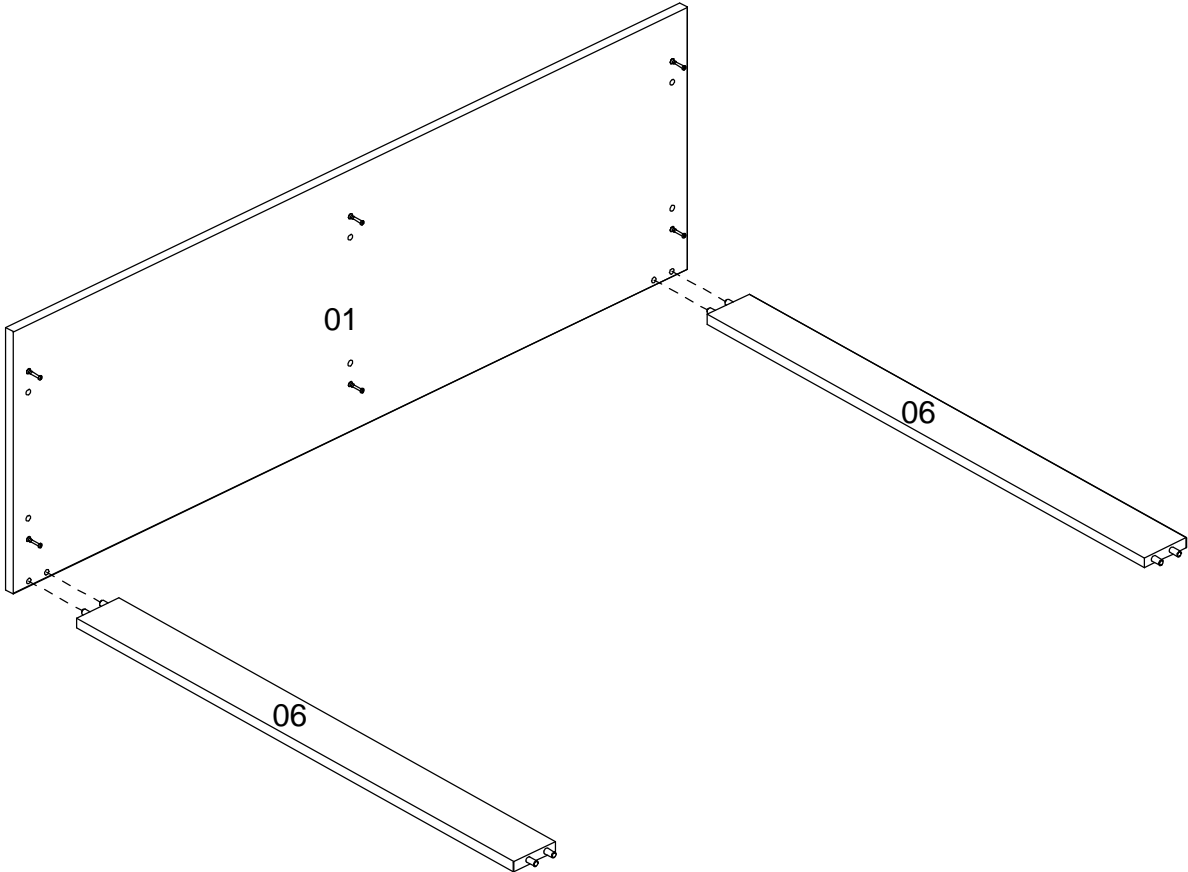

09

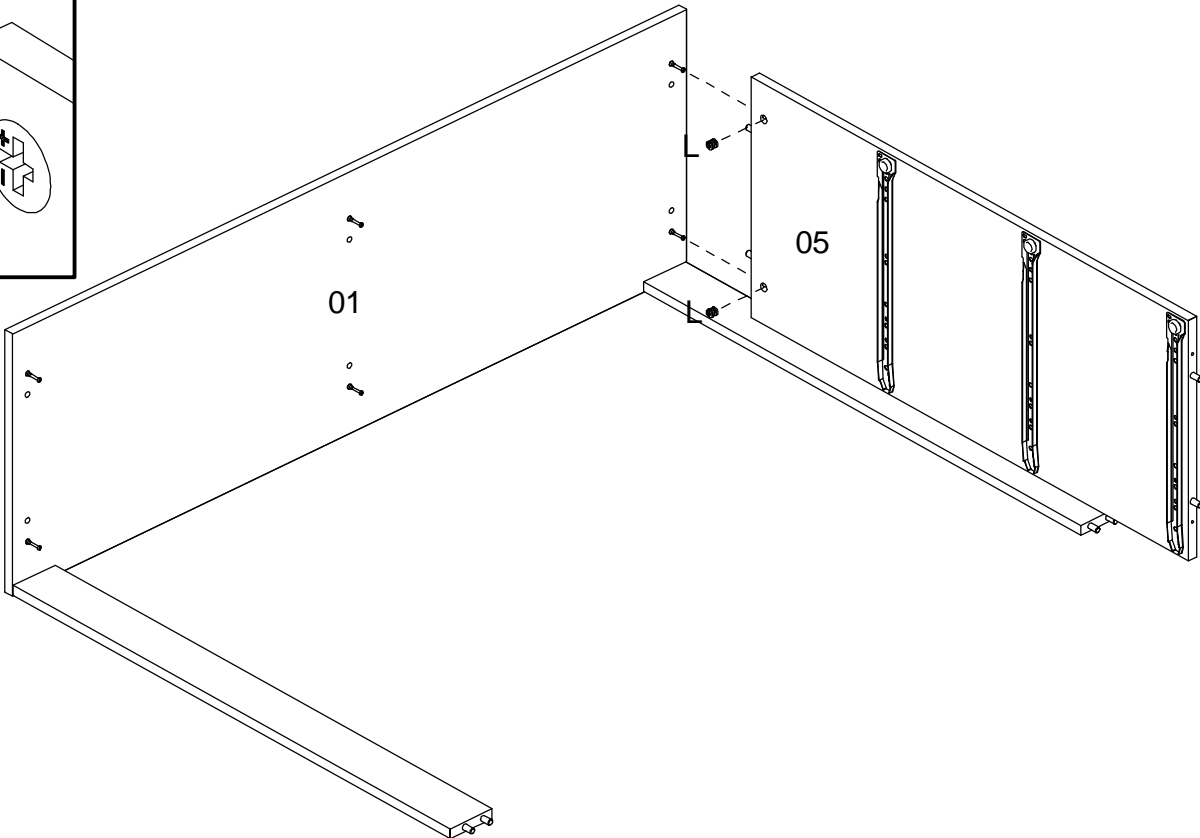
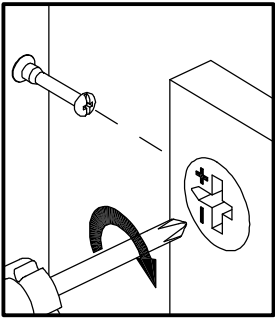

10

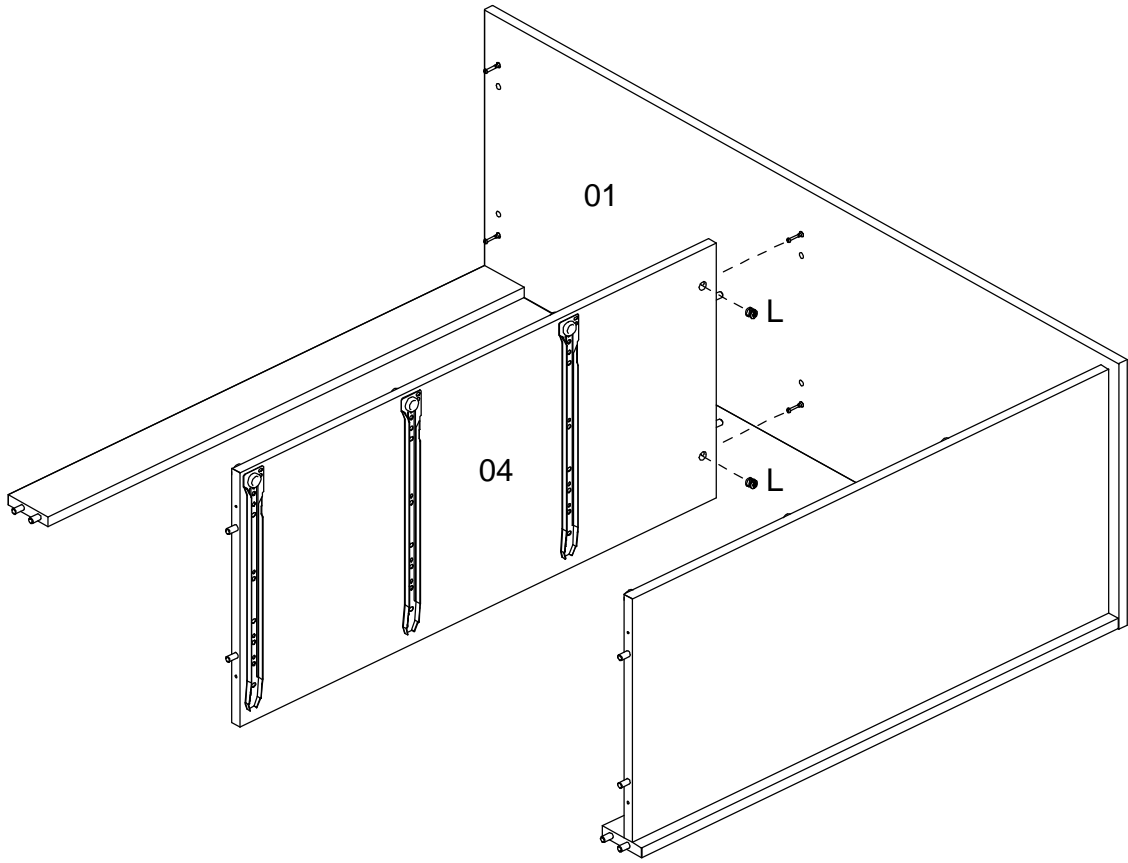

11

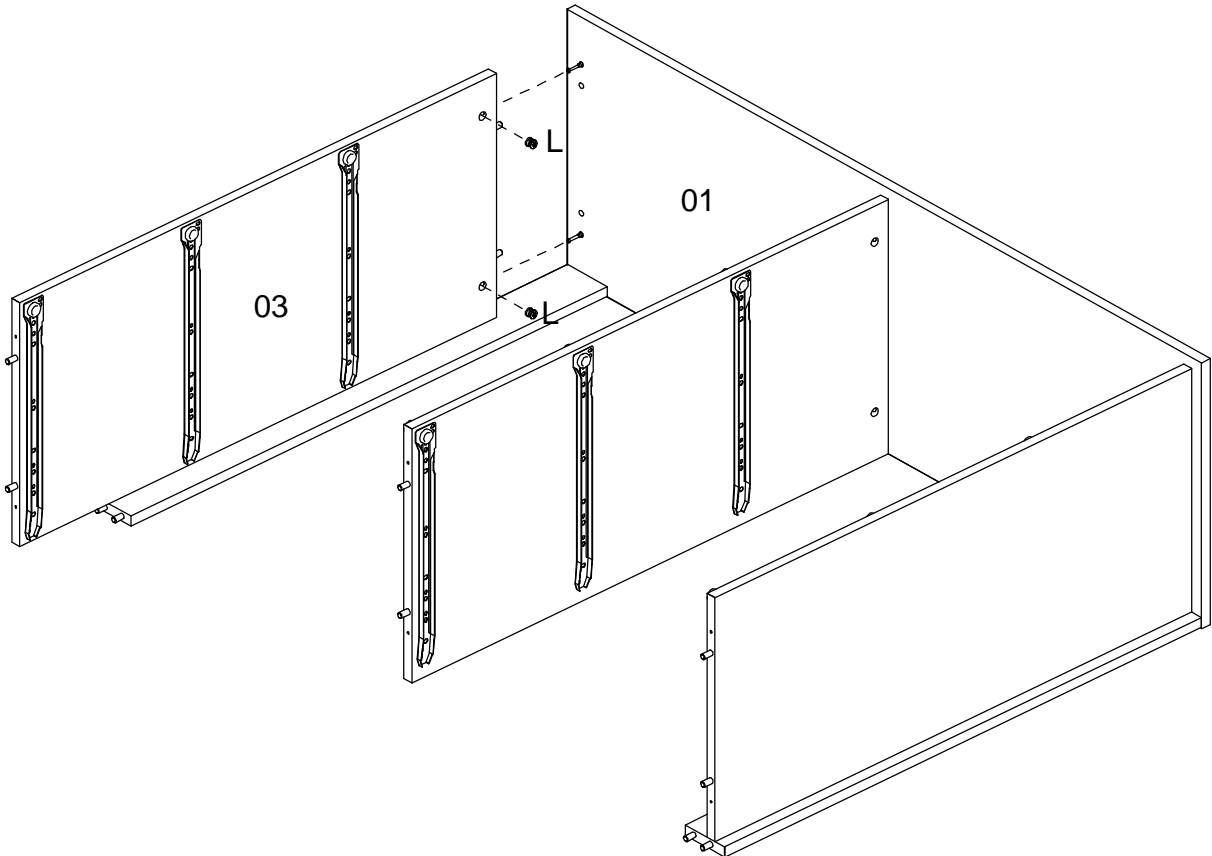

12

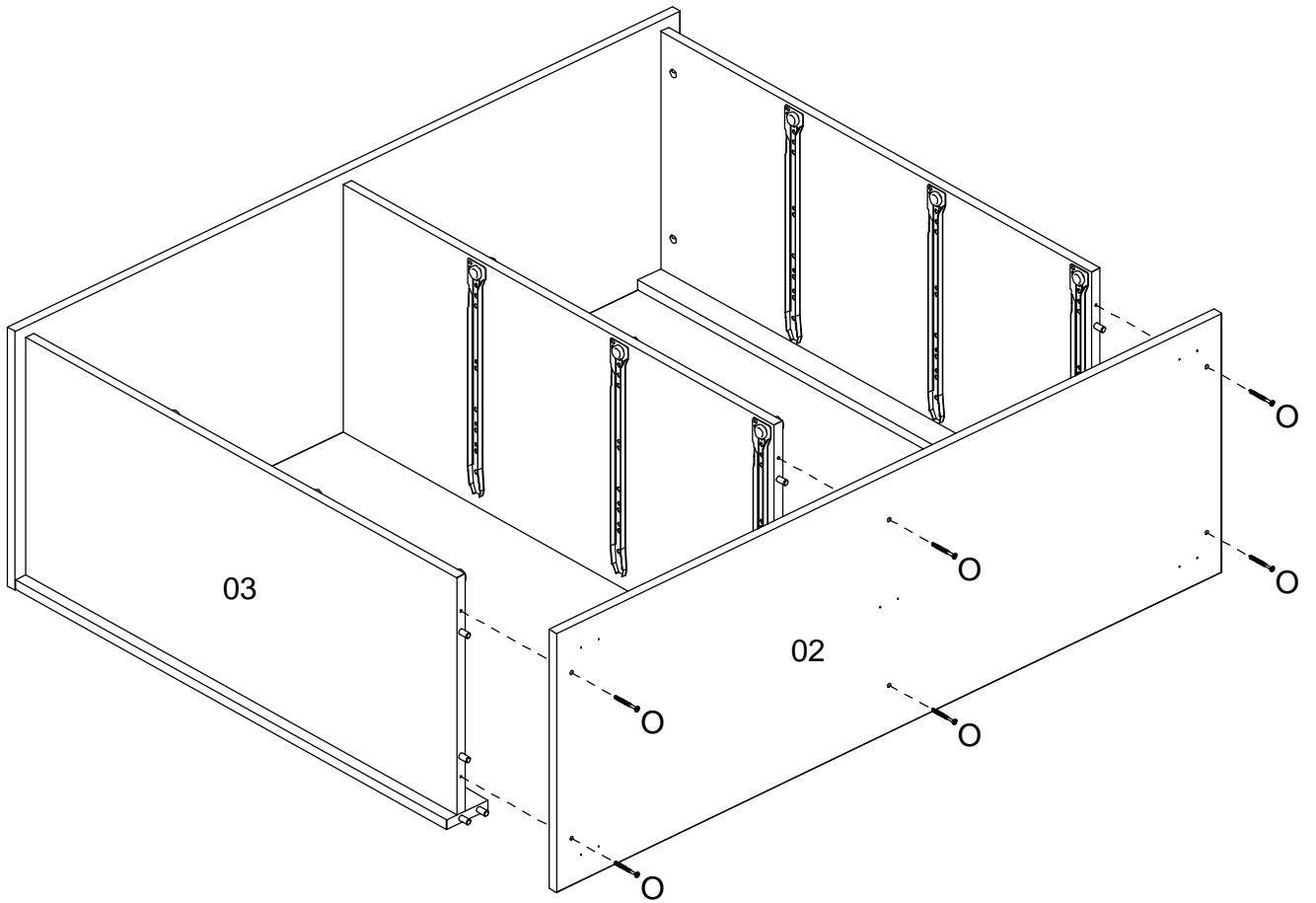

13

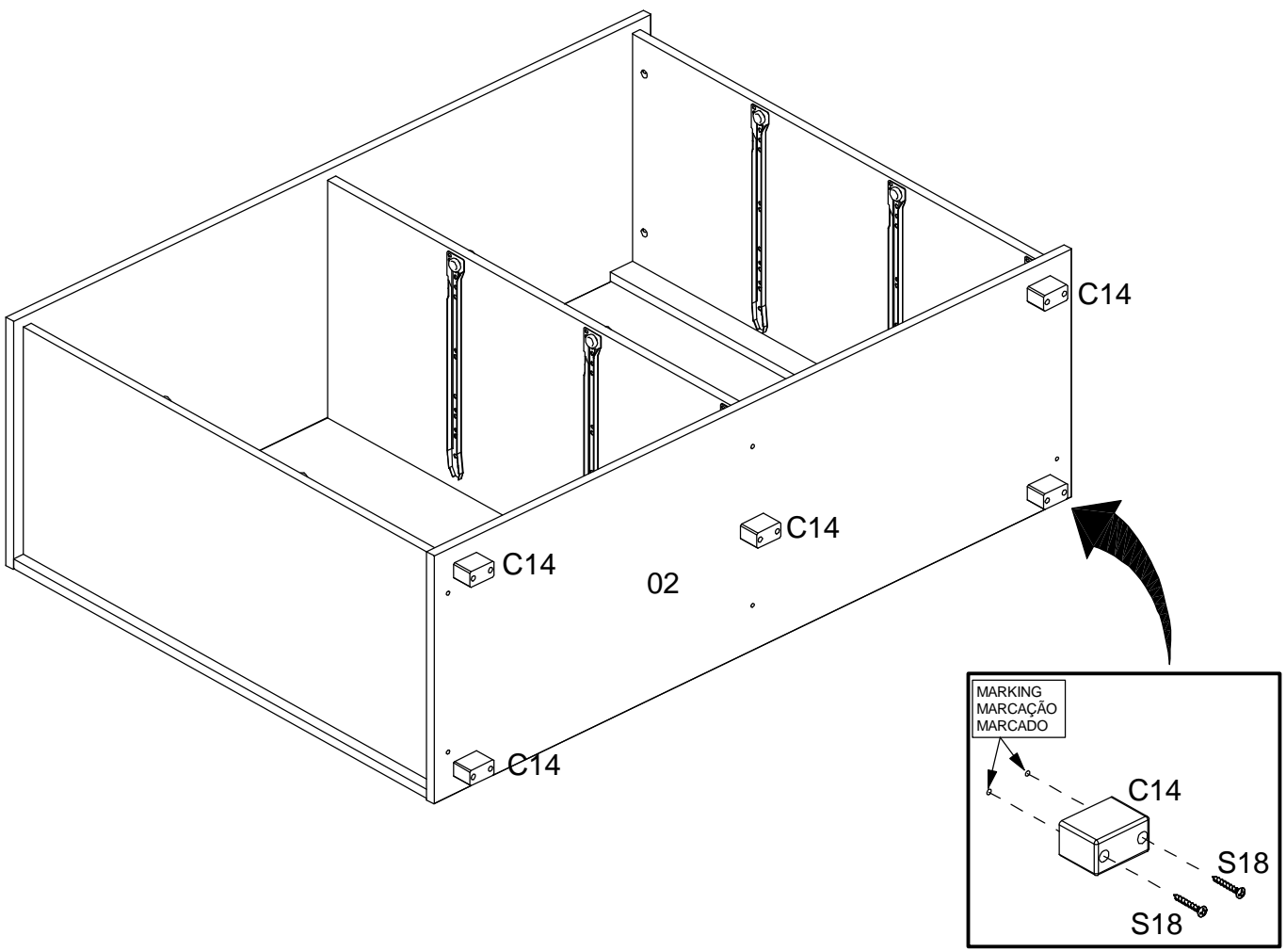

14

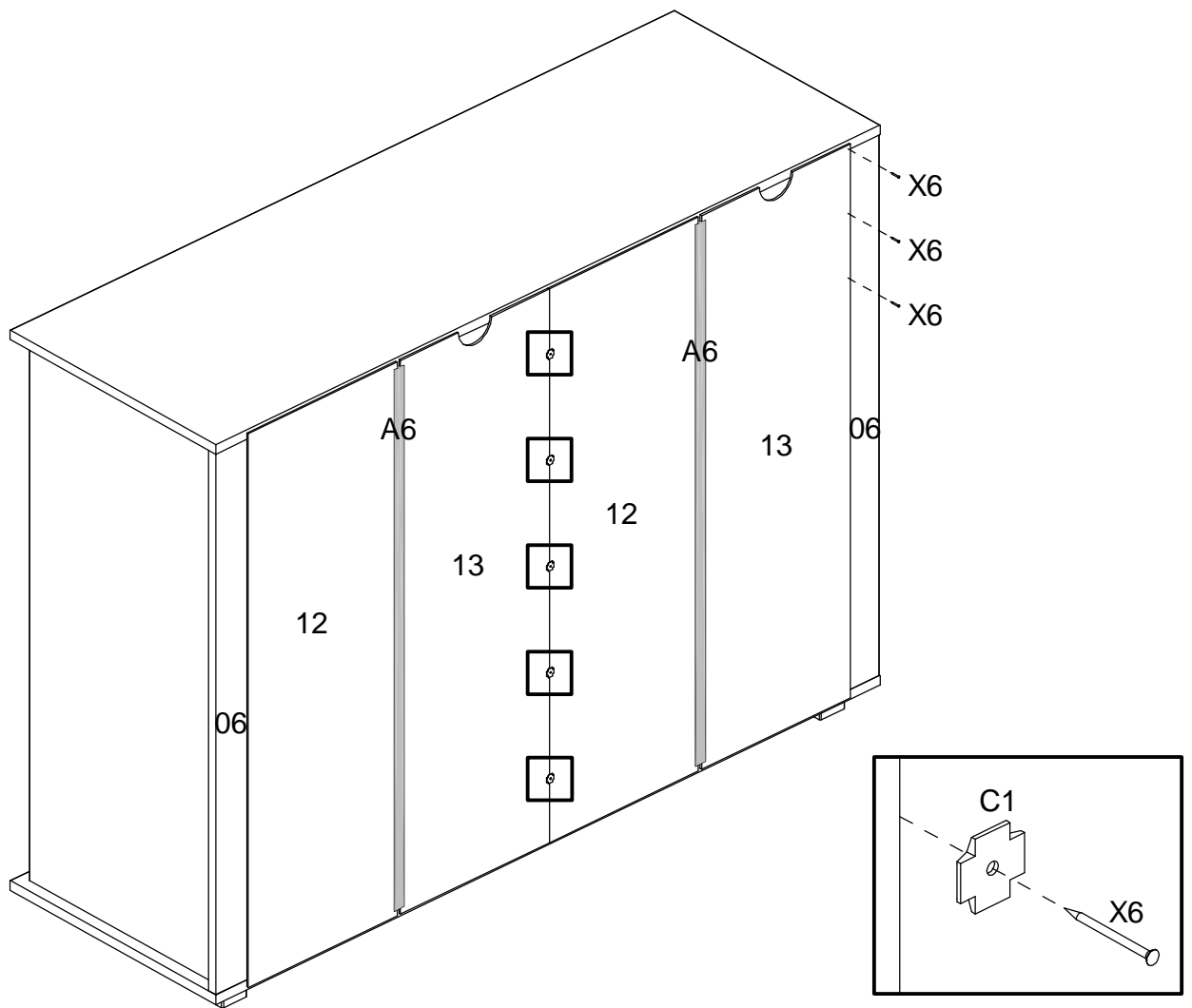

15

TO AVOID ANY INJURY THE FURNITURE MUST BE FIXED ON THE WALL. THANKS.
 PARA EVITAR QUALQUER ACIDENTE, É OBRIGATÓRIO FIXAR O MÓVEL NA PAREDE. OBRIGADO!
 PARA EVITAR CUALQUIER ACCIDENTE ES OBLIGATORIO ANCLAR EL MUEBLE EN LA PARED. GRACIAS.

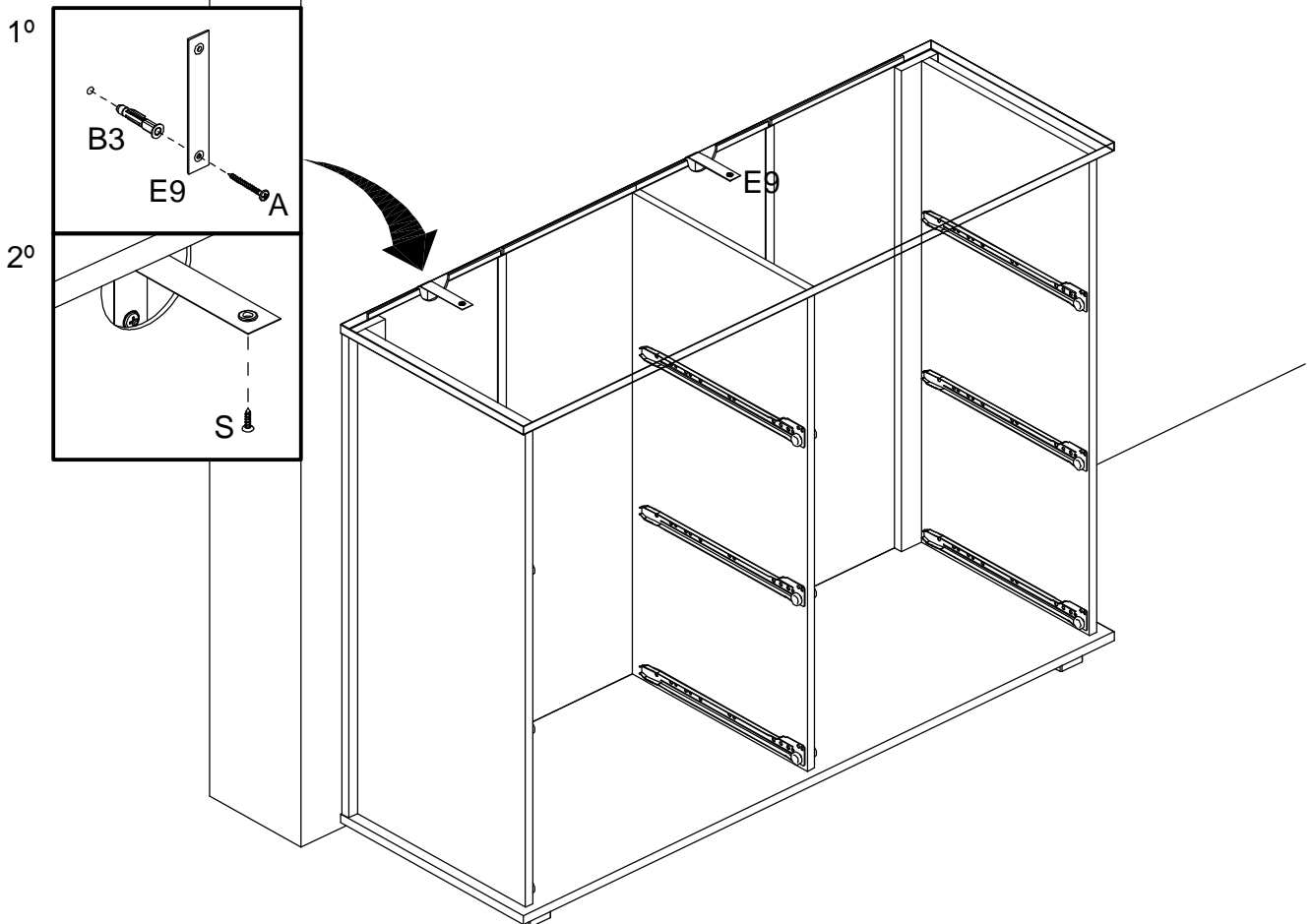

16

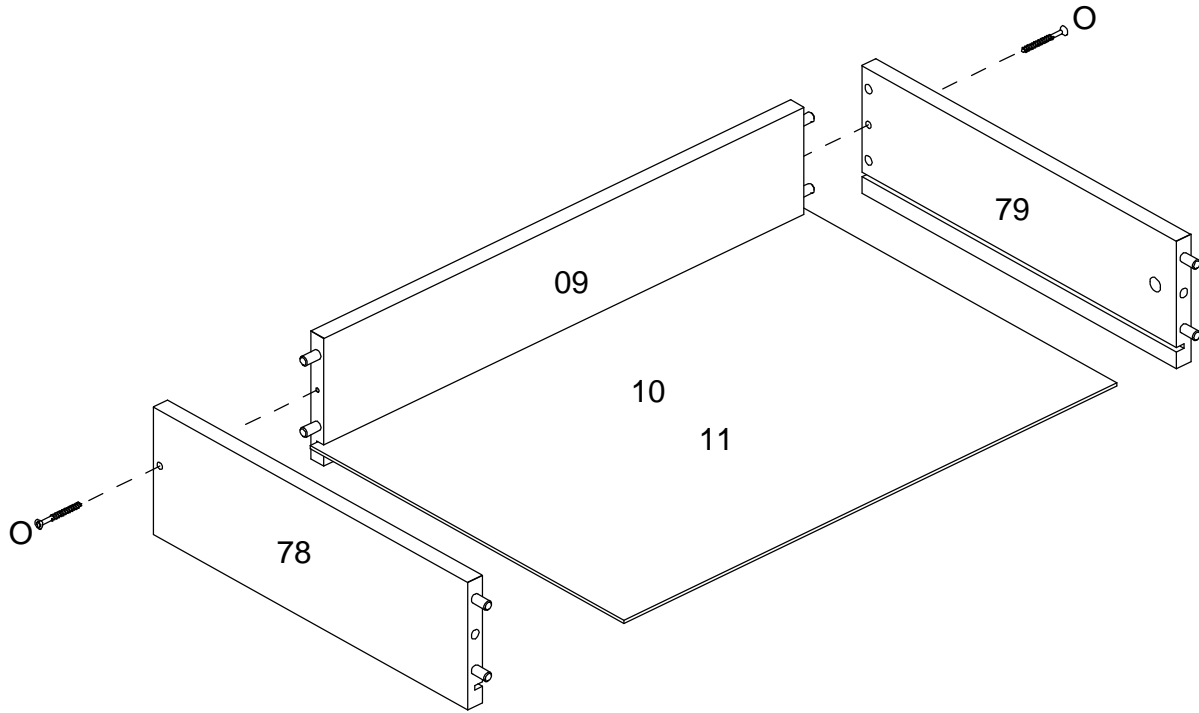

17

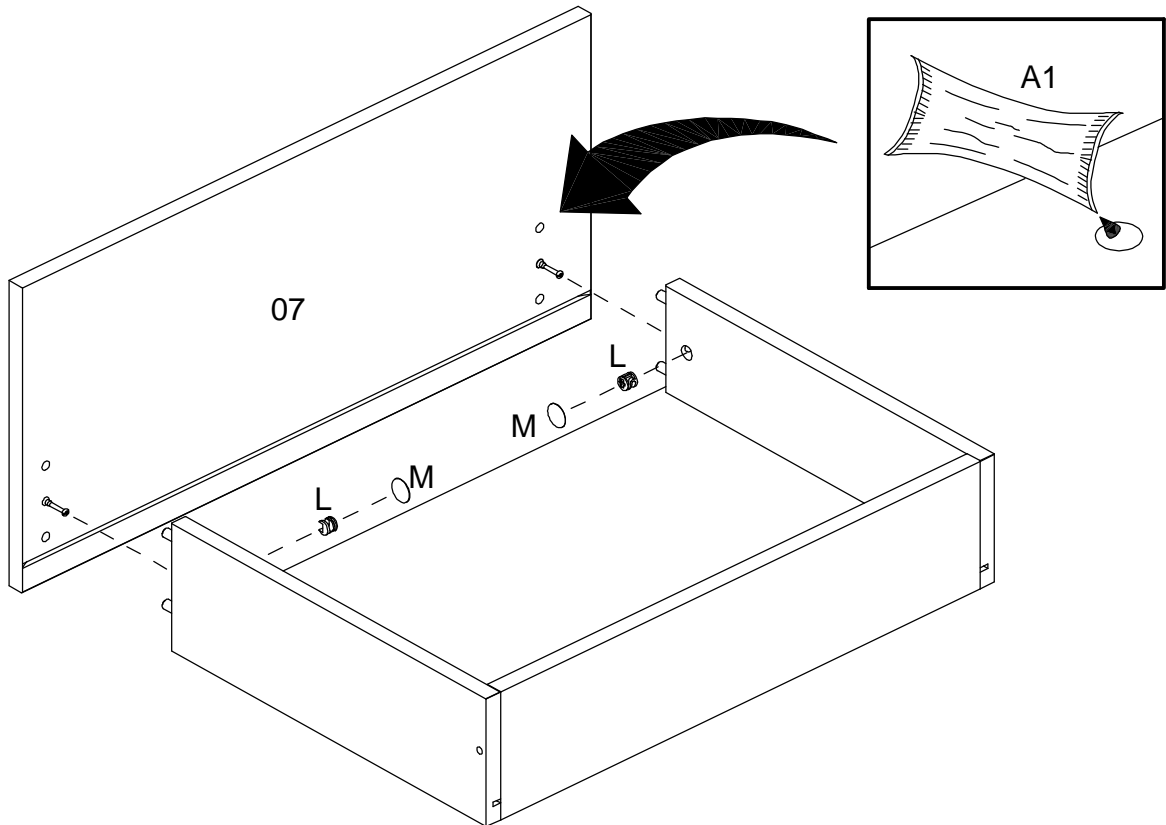

18

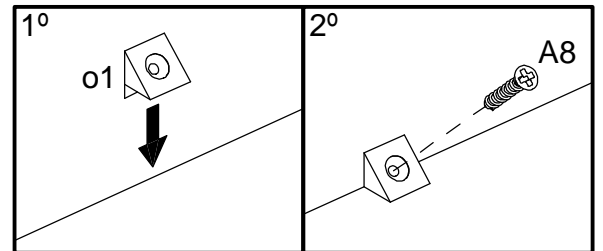
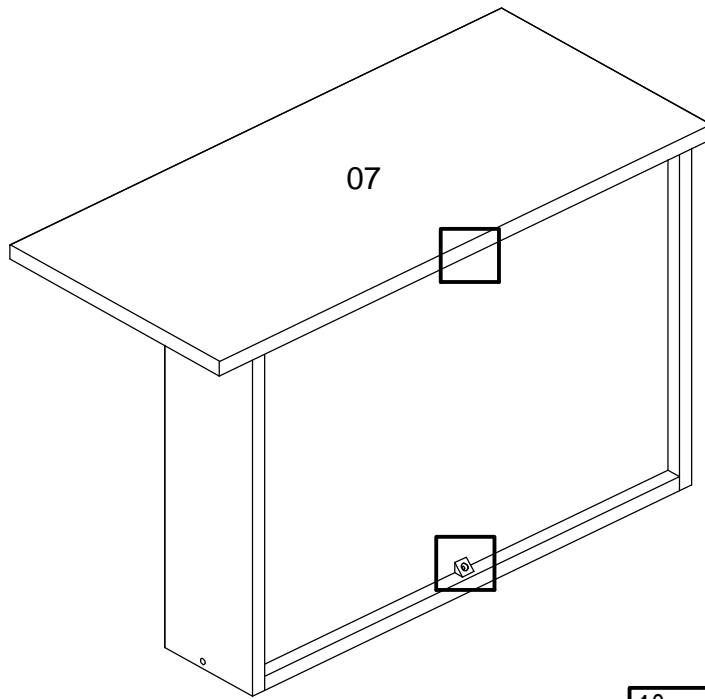

19

THE UNDERSIDE OF THE DRAWER
LADO INFERIOR DA GAVETA
PARTE INFERIOR DEL CAJÓN

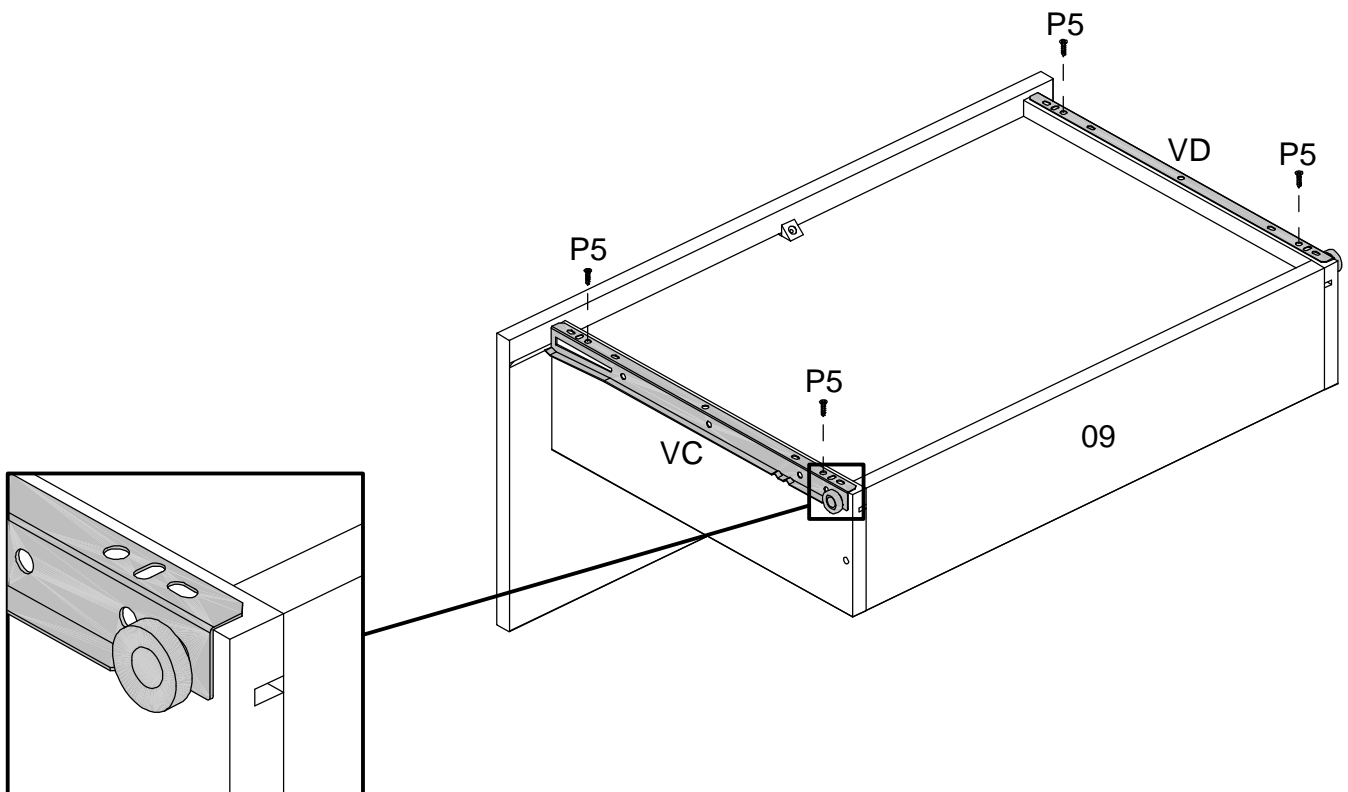

20

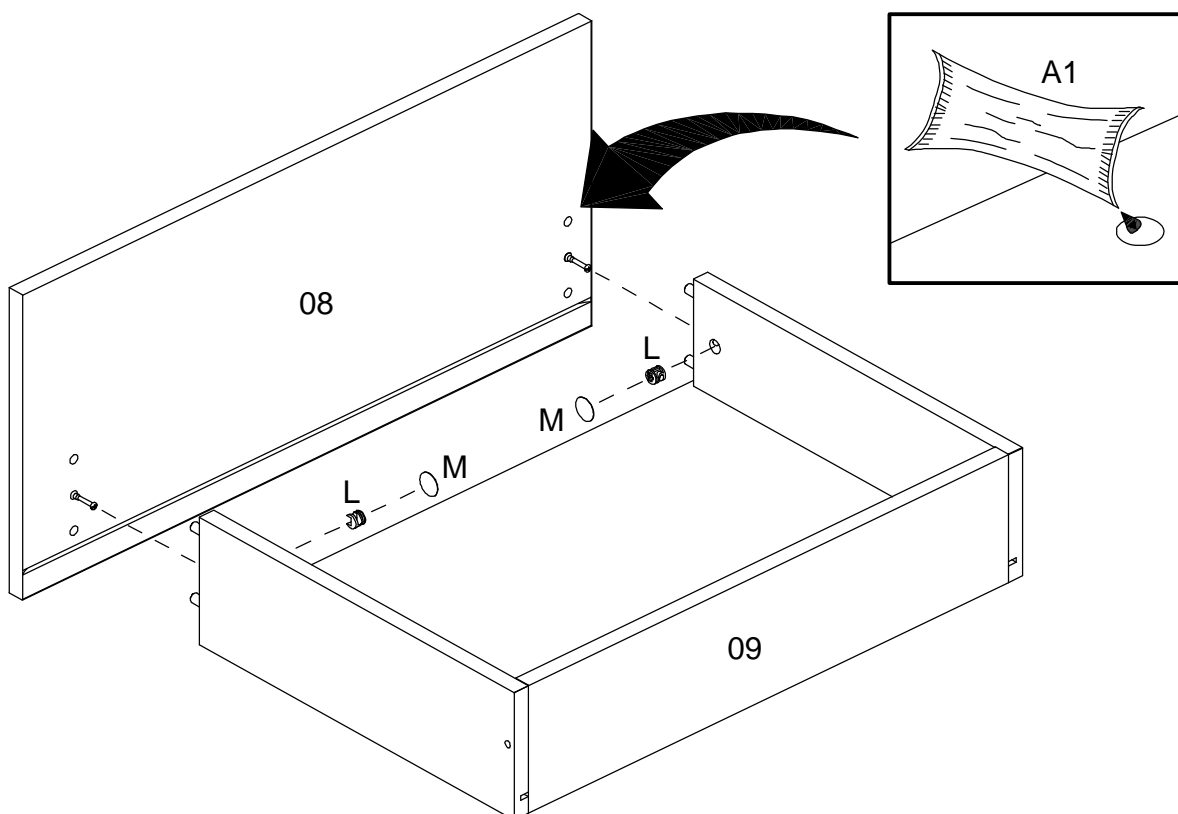

21

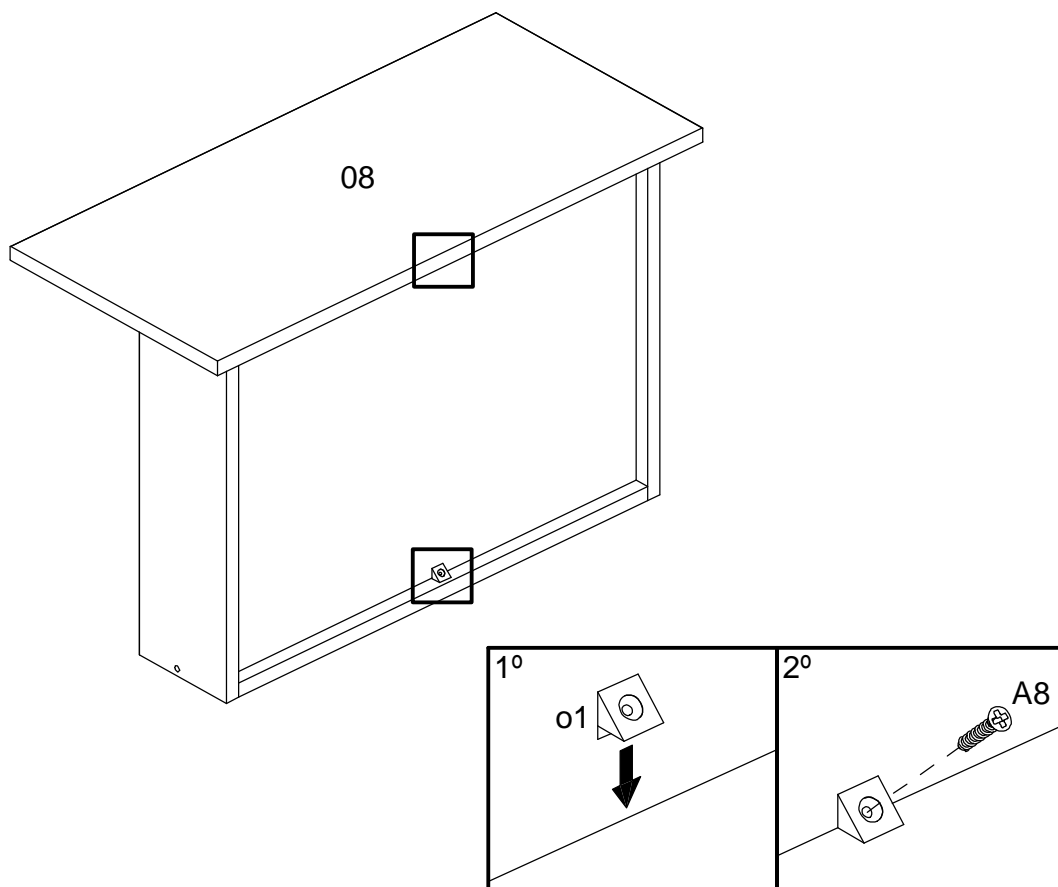

22

THE UNDERSIDE OF THE DRAWER
LADO INFERIOR DA GAVETA
PARTE INFERIOR DEL CAJÓN

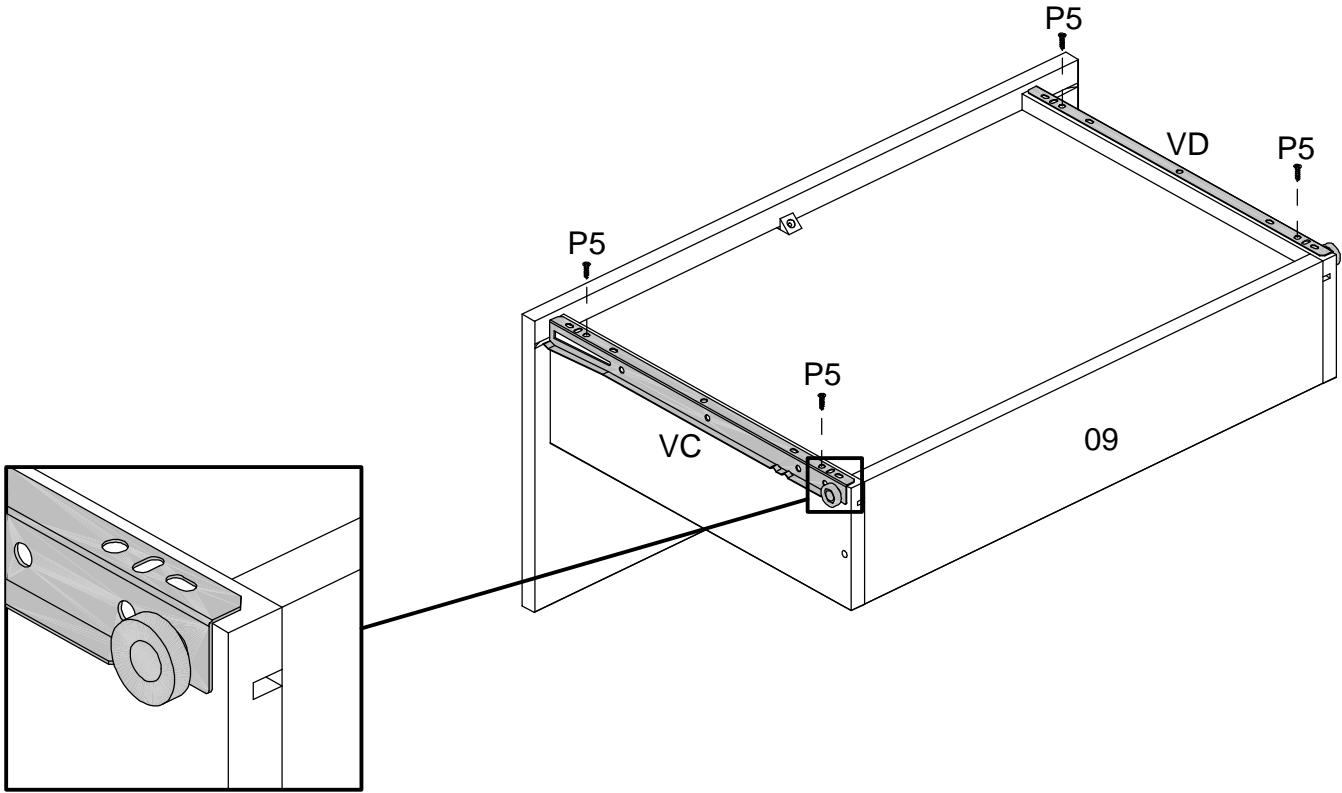

23

