

CO9100 - AÉREO 1,20 M

Manual de Montagem
Assembly Instructions
Instrucción de Montaje

decibal[®]
móveis

Produto Montado
Producto final
Assembled

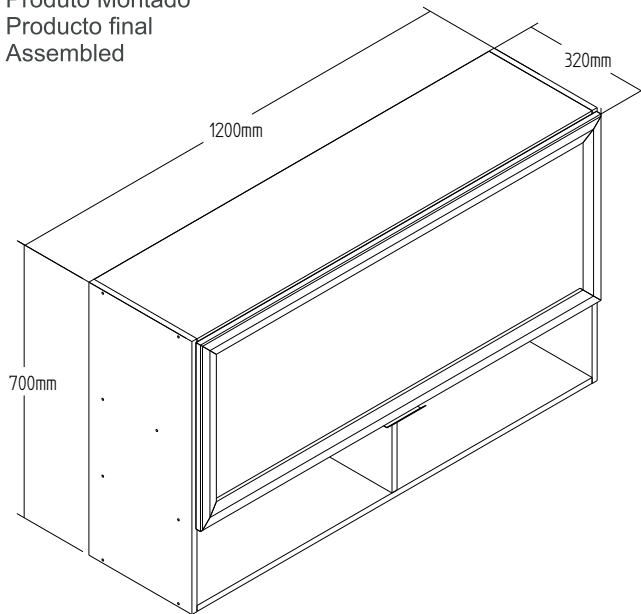

01°

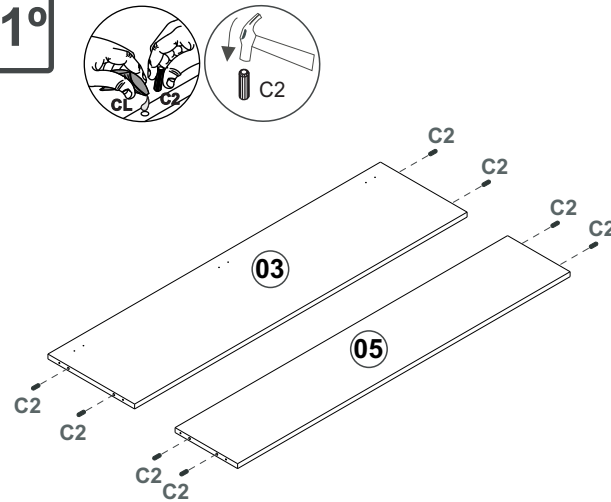

02°

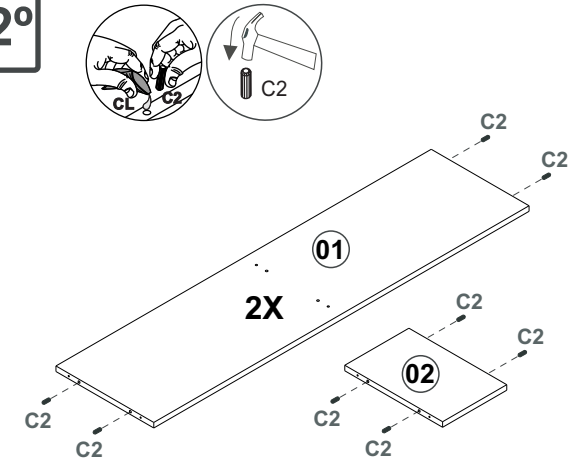

03°

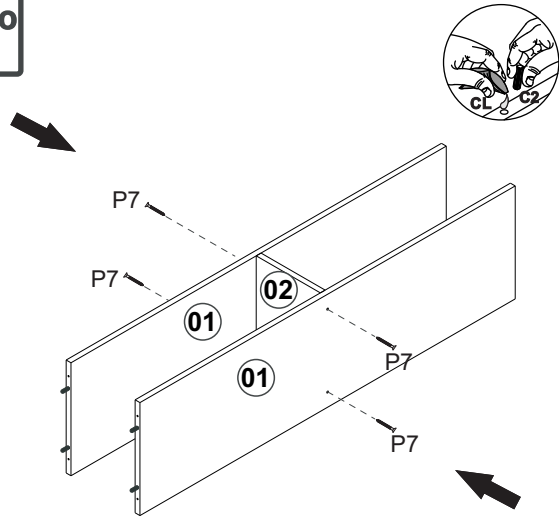

04°

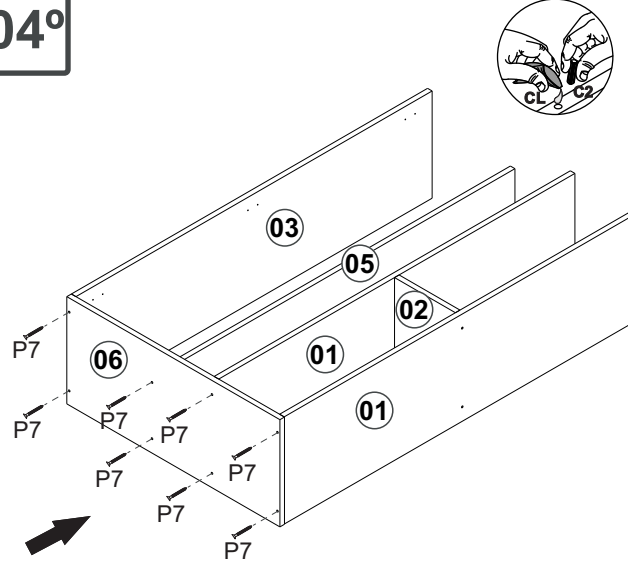

05°

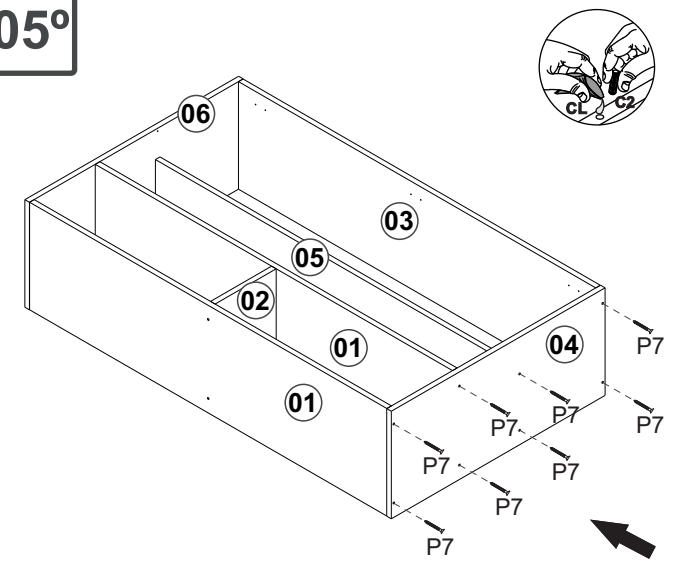

CO9100 - AÉREO 1,20 M

Manual de Montagem
 Assembly Instructions
 Instrucción de Montaje



6º COSTA/REVÉS/BACK

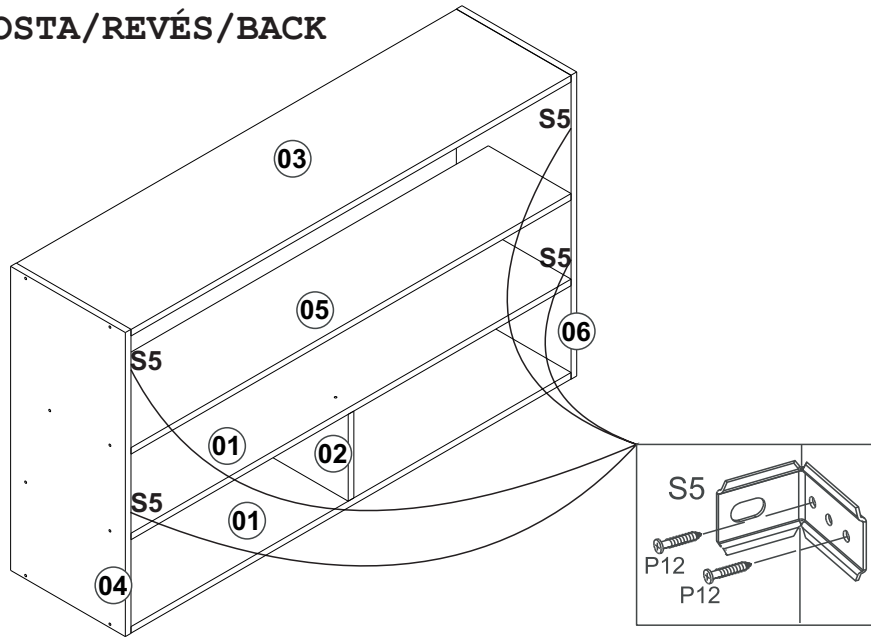

08º

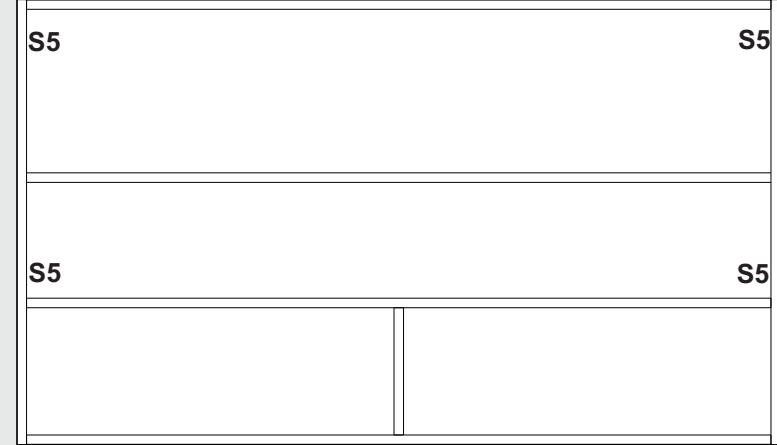

FIXAÇÃO NA PAREDE / FIJACIÓN EN LA PARED / FIXING ON THE WALL

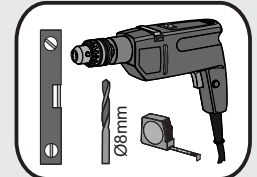
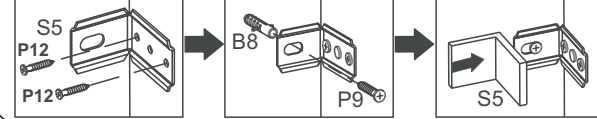

7º COSTA/REVÉS/BACK

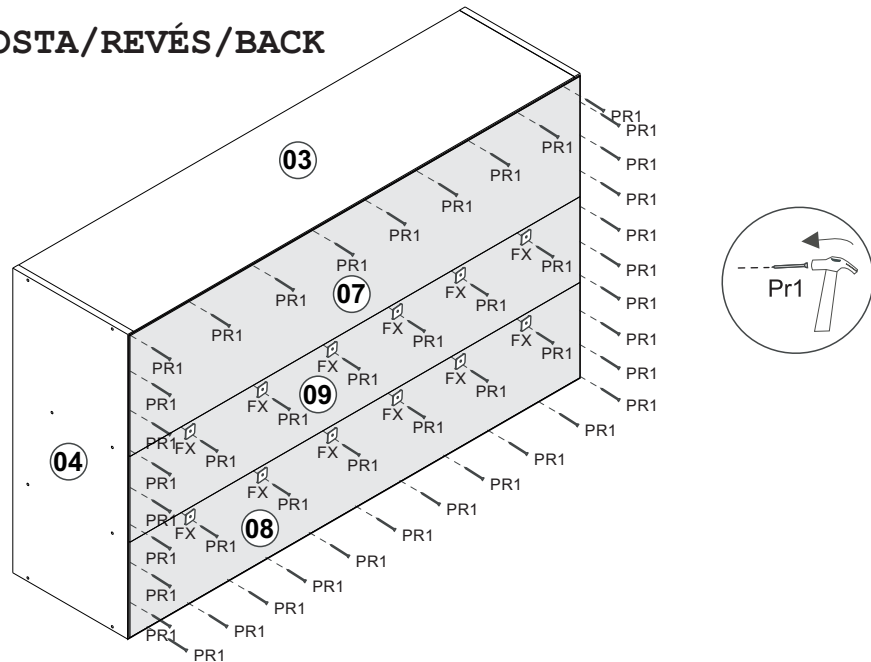

PESO SUPORTADO / PESO SOPORTADO / WEIGHT SUPPORTED

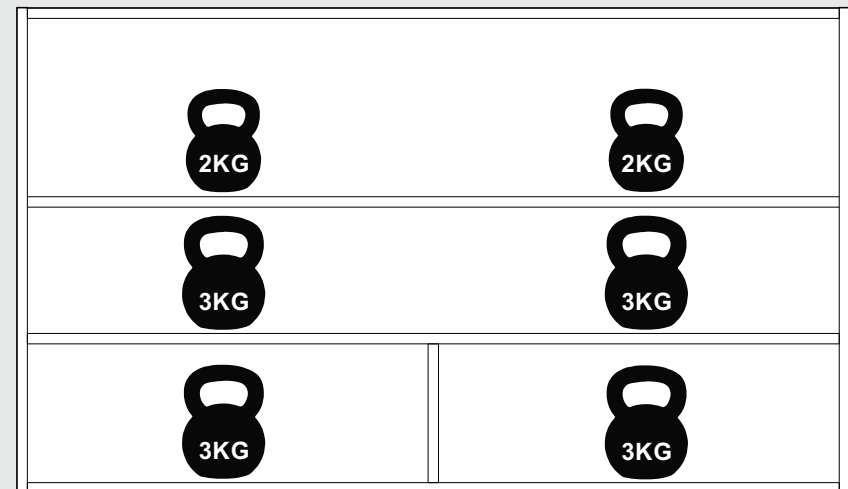

09°

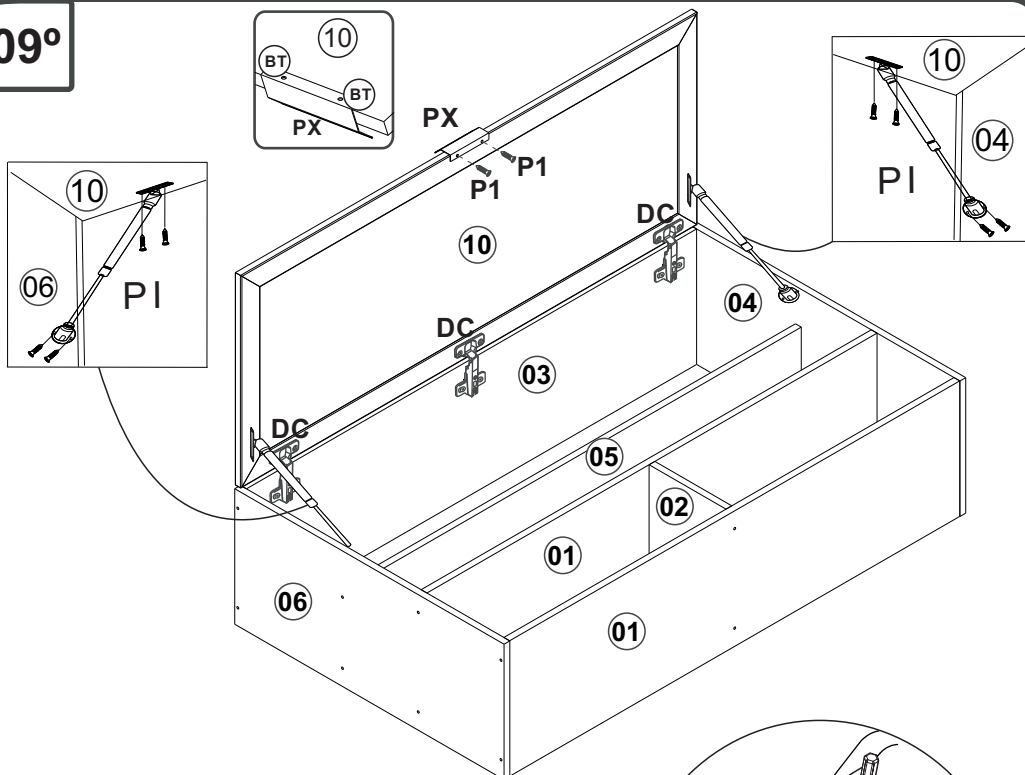

ATENÇÃO!!!!

MARCAÇÃO PRA O PRIMEIRO FURO DO PUXADOR

MARCADO PARA EL PRIMER AGUJERO

MARKING FOR THE FIRST HANDLE HOLE

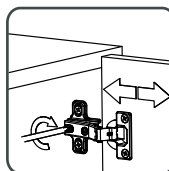
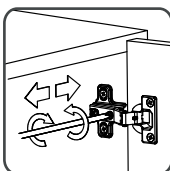
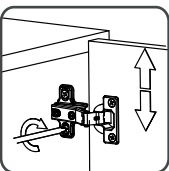
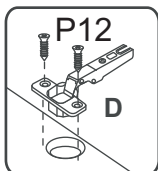
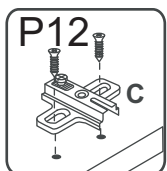
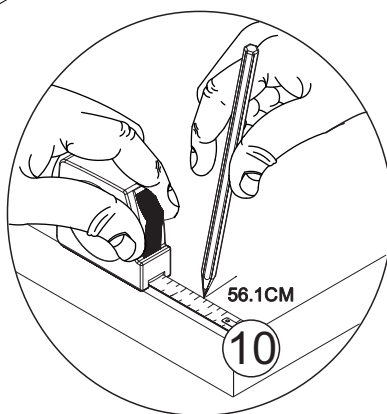

Relação de Peças/ Relación de Piezas/Parts List

Nº	CÓDIGO/CODE	DESCRIÇÃO/DESCRIPCIÓN/DESCRIPTION	QTD/CANT	VOL.	
1	0549198	BASE	1170X305X15MM	2	1
2	0549207	DIVISORIA DIR/DIVIDER	305X200X15MM	1	1
3	0549202	TAMPO/TAPA/TOP	1170X305X15MM	1	1
4	0549199	LATERAL DIR/LATERAL/SIDE	700X305X15MM	1	1
5	0549203	PRATELEIRA MENOR/ESTANTE/SHELF	1170X220X15MM	1	1
6	0549200	LATERAL ESQ/LATERAL/SIDE	700X305X15MM	1	1
7	0549206	COSTA SUP/REVÉS/BACK	1194X277X2, 8MM	1	1
8	0549205	COSTA MAIOR/REVÉS/BACK	1194X219X2, 8MM	1	1
9	0549204	COSTA MENOR/REVÉS/BACK	1194X197X2, 8MM	1	1
10	11970	PORTA/PUERTA/DOOR	1186X478X15MM	1	2

ATENÇÃO!!!! montadores e consumidores

* Para limpar o móveis utilize somente um pano úmido (umedecido em água pura ou água com sabão neutro). Depois, passe um pano seco. Evite a umidade excessiva.

* Evite usar álcool, água sanitária, detergente e outros produtos químicos, mesmo diluídos em água. Não utilize produtos abrasivos de nenhuma espécie

ATENCIÓN!!!! montadores e consumidores

* Para limpiar el mueble utilice solamente un paño húmedo (humedecido con agua limpia o con un jabón suave).

A continuación, utilice un paño seco. Evite el exceso de humedad.

* Evite uso de alcohol, hipoclorido solución basada, detergente y otros productos químicos, mismo diluídos en agua. No utilice productos abrasivos de ningún tipo.

ATTENTION!!!! assemblers and consumers

*To clean the furniture, use only a damp cloth (humidify it only in pure water ou water and neutral soap).After, use a dry cloth.Avoid excessive humidity.

*Avoid using alcohol, bleach, detergent and other chemical products, even diluted in water. Do not use any kind of abrasive cleaning agents to clean the furniture.

The use of such products may jeopardize the ?nal characteristics of the furniture.

www.decibal.com.br

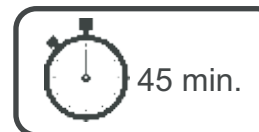





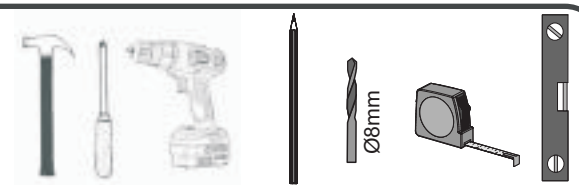

45 min.













Ferramente necessárias
Necessary tools
Herramientas necesarias



Ferragens/ Herrerajes/ Hardware

		escala (1:1)	
LEGENDA	DESCRIÇÃO/DESCRIPCIÓN/DESCRIPTION	CÓDIGO	QUANT.
P7	 PARAFUSO/TORNILLO/SCREW 4X45	01318	20
PR1	 PREGO/CLAVO/NAIL 10X10	01330	80
C2	 CAVILHA/TARUGO/DOWEL 6X30 MM	01211	21
P1	 PARAFUSO/TORNILLO/SCREW 3,5X12	01328	02
PU	 PARAFUSO UNIÃO/UNIÓN DETORNILLO /SCREW UNION	01495	02
P12	 PARAFUSO/TORNILLO/SCREW 3,5X13	09927	20
P9	 PARAFUSO/TORNILLO/SCREW 6X50	03827	04

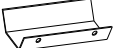
escala (N/A)

		escala (N/A)	
LEGENDA	DESCRIÇÃO/DESCRIPCIÓN/DESCRIPTION	CÓDIGO	QUANT.
CL	 COLA/PEGAMENTO/GLUE	01213	01
ET	 ETIQUETA LOGO DECIBAL/LABEL DECIBAL	01312	01
B1	 BUCHA/BUJE/BUCHING (8mm)	01311	04
DC	 DOBRADIÇA/BISAGRA/HINGE D=35mm C=0mm	09449	03
S5	 SUPORTE AÉREO/APOYO AÉREO/AIR SUPPORT EBANO 04501	03828	04
FX	 FIXADOR COSTA/FIJADOR FONDO/FIXER COAST	01331	20
AD	ADESIVO/ADHESIVO/ADHESIVE  NATURALLE 09963		20
BT	 BATENTE/BATIENTE DE SILICONA/SILICONE STOP 8MM	02921	02
PX	 PUXADOR/PEGADOR /HANDLE (MOV410 /100MM)	11440	01
PI	 PISTÃO GÁS / PISTÓN DE GAS /GAS PISTON	01265 80N	02

ATENÇÃO!!!! montadores e consumidores
* Ajustar o torque da parafusadeira para não danificar as peças escareando o parafuso *

ATENCIÓN!!!! montadores e consumidores
* Ajuste el torque del destornillador para no dañar las piezas avallanando el tornillo *

ATTENTION!!!! assemblers and consumers
* Adjust the torque of the screwdriver so as not to damage the parts by countersinking the screw *

Medida em mm



CO9103 - PANELEIRO

Manual de Montagem
Assembly Instructions
Instrucción de Montaje

decibal[®]
móveis

Produto Montado
Producto final
Assembled

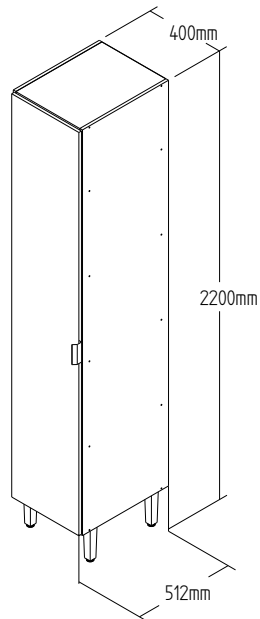

01°

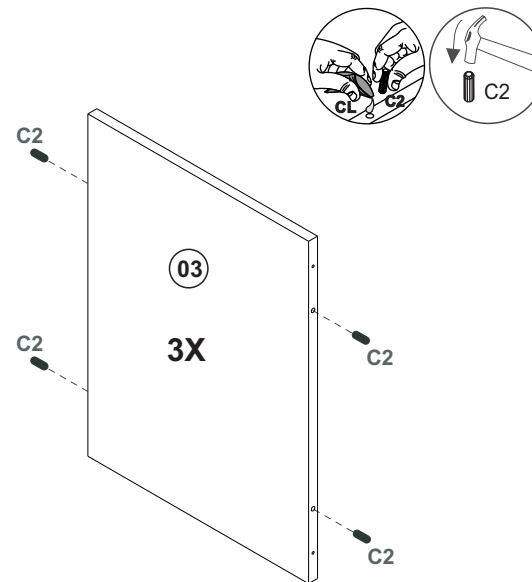

02°

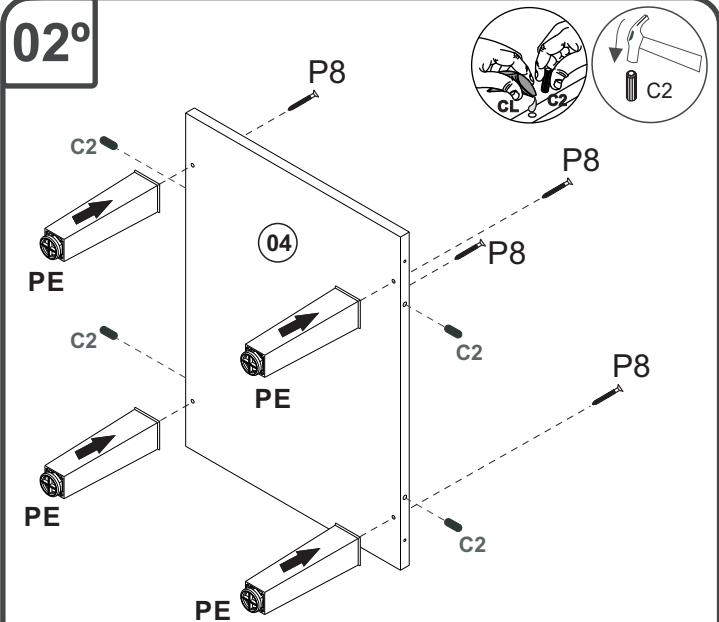

03°

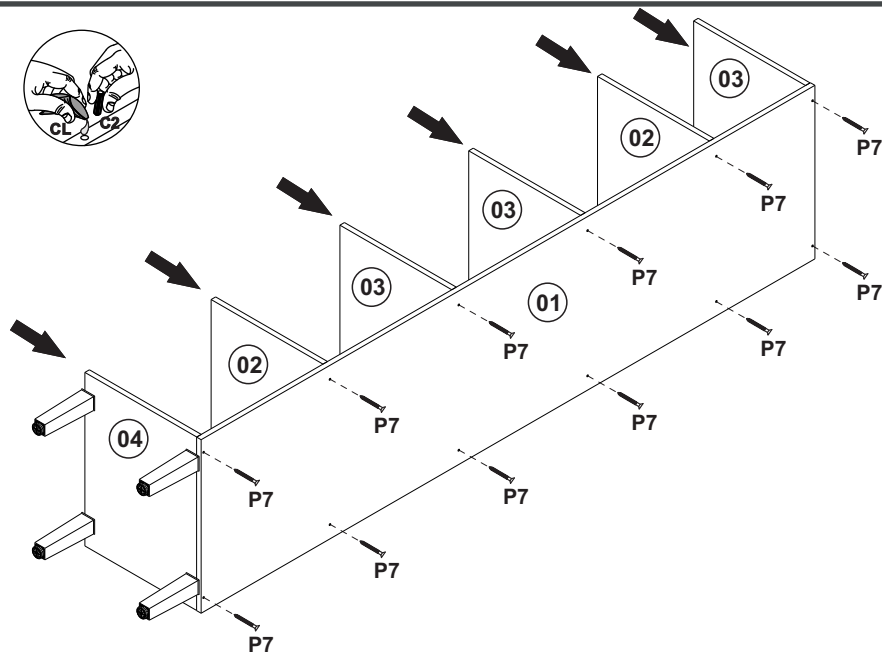

04°

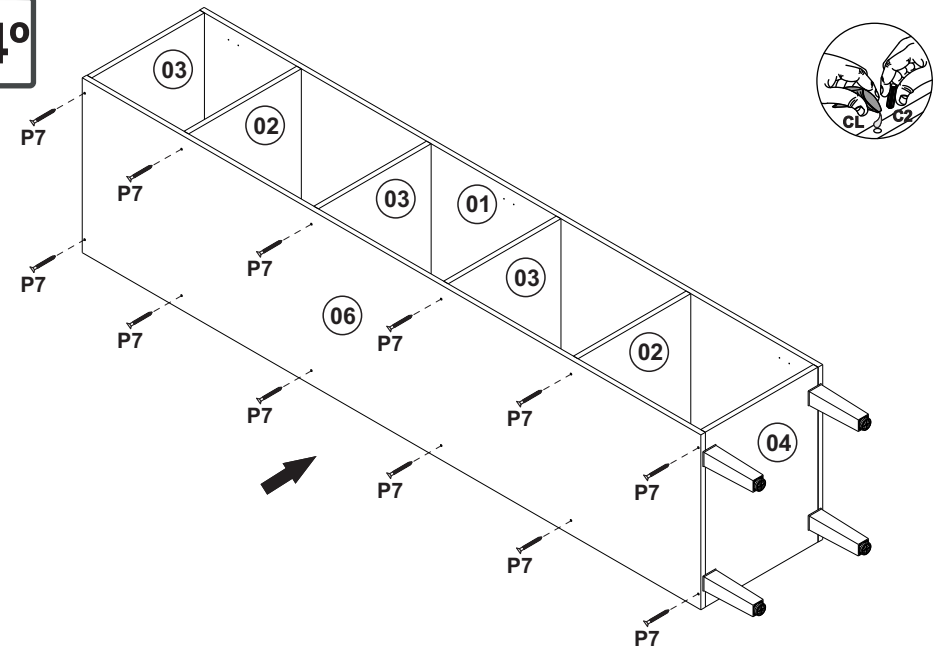

CO9103 - PANELEIRO

Manual de Montagem
Assembly Instructions
Instrucción de Montaje

decibal[®]
móveis

05°

COSTA/REVÉS/BACK

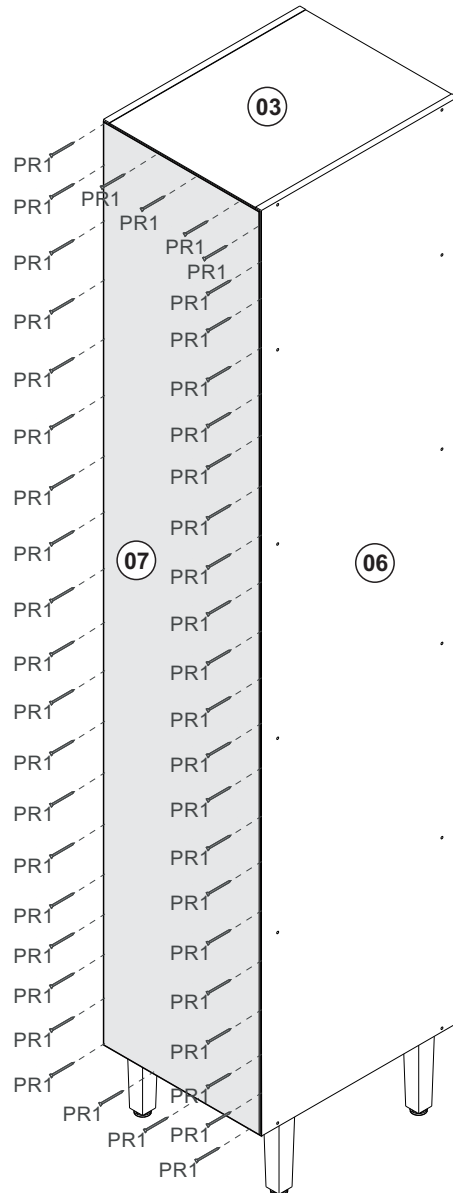
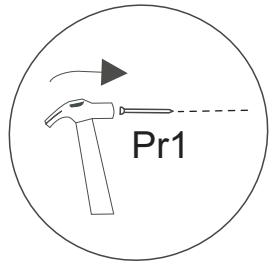

06°

PESO SUPORTADO/PESO SOPORTADO/WEIGHT SUPPORTED



CO9103 - PANELEIRO

Manual de Montagem
Assembly Instructions
Instrucción de Montaje

decibal[®]
móveis

7°

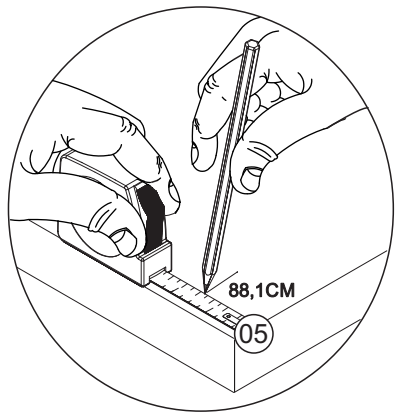
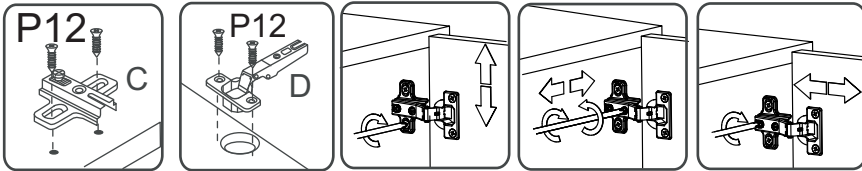

ATENÇÃO!!!!





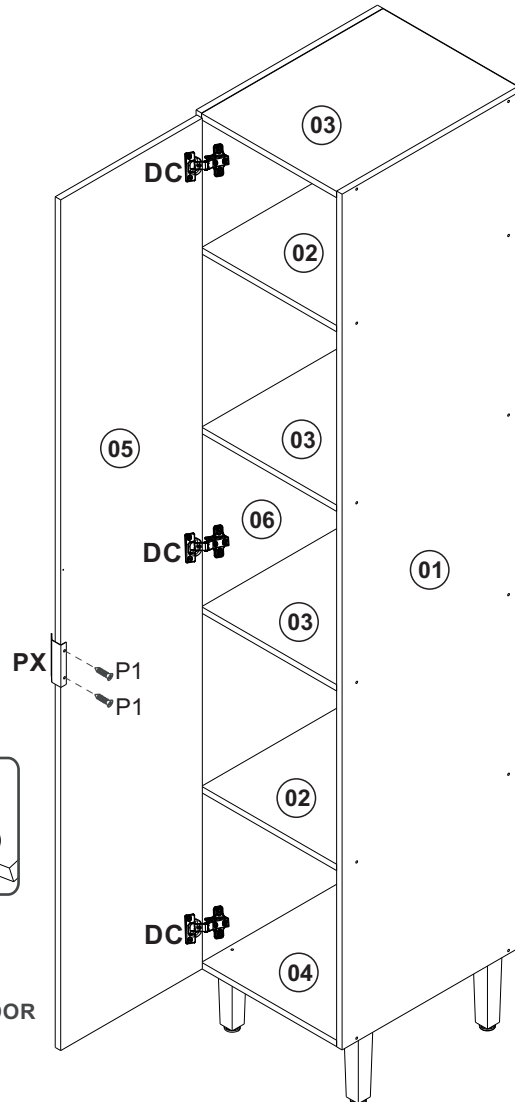

MARCAÇÃO PRA O PRIMEIRO FURO DO PUXADOR

MARCADO PARA EL PRIMER AGUJERO

MARKING FOR THE FIRST HANDLE HOLE

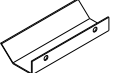

escala (N/A)

LEGENDA	DESCRIÇÃO/DESCRIPCIÓN/DESCRIPTION	CÓDIGO	QUANT.
CL	 COLA/PEGAMENTO/GLUE	01213	01
ET	 ETIQUETA LOGO DECIBAL/LABEL DECIBAL	01312	01
AD	 ADESIVO/ADHESIVO/ADHESIVE	(GRISEO)11895	25
PX	 PUXADOR/PEGADOR /HANDLE (MOV410 /100MM)	11440	01
BT	 BATENTE/BATIENTE DE SILICONA/SILICONE STOP 8MM	02921	02
DC	 DOBRADIÇA/BISAGRA/HINGE D=35mm C=0	09449	03
PE	 PÉ/PATA/FOOT (170MM)	11121	04

CO9103 - PANELEIRO

Manual de Montagem
Assembly Instructions
Instrucción de Montaje



Ferragens/ Herrerajes/ Hardware escala (1:1)

LEGENDA	DESCRIÇÃO/DESCRIPCIÓN/DESCRIPTION	CÓDIGO	QUANT.
P7	 PARAFUSO/TORNILLO/SCREW 4X45	01318	24
PR1	 PREGO/CLAVO/NAIL 10X10	01330	60
C2	 CAVILHA/TARUGO/DOWEL 6X30 MM	01211	17
P12	 PARAFUSO/TORNILLO/SCREW 3,5X13 CABEÇA FLANGEADA	09927	12
P1	 PARAFUSO/TORNILLO/SCREW 3,5X12	01328	02
P8	 PARAFUSO/TORNILLO/SCREW 5X45	01320	04
PU	 PARAFUSO UNIÃO/UNIÓN DETORNILLO /SCREW UNION	01495	02

Relação de Peças/ Relación de Piezas/Parts List

Nº	CÓDIGO/CODE	DESCRIÇÃO/DESCRIPCIÓN/DESCRIPTION	QTD/CANT	VOL.
1	0548820	LATERAL DIR/LATERAL/SIDE 2030X497X15MM	1,00	1
2	0549156	PRATELEIRA/ESTANTE/SHELF 497X370X15MM	2,00	1
3	0548819	BASE 497X370X15MM	3,00	1
4	0548663	BASE INF 497X370X15MM	1,00	1
5	0548823	PORTA/PUERTA/DOOR 2018X388X15MM	1,00	1
6	0548821	LATERAL ESQ/LATERAL/SIDE 2030X497X15MM	1,00	1
7	0548822	COSTA/REVÉS/BACK 2124X394X2,8MM	2,00	2

ATENÇÃO!!!! montadores e consumidores
* Ajustar o torque da parafusadeira para não danificar as peças escareando o parafuso *

ATENCIÓN!!!! montadores e consumidores
* Ajuste el torque del destornillador para no dañar las piezas avallando el tornillo *



ATTENTION!!!! assemblers and consumers
* Adjust the torque of the screwdriver so as not to damage the parts by countersinking the screw *

Ferramenta necessária
Necessary tools
Herramientas necesarias



ATENÇÃO!!!! montadores e consumidores
* Para limpar o móveis utilize somente um pano úmido (umedecido em água pura ou água com sabão neutro). Depois, passe um pano seco. Evite a umidade excessiva.
* Evite usar álcool, água sanitária, detergente e outros produtos químicos, mesmo diluídos em água. Não utilize produtos abrasivos de nenhuma espécie

ATENCIÓN!!!! montadores e consumidores
* Para limpiar el mueble utilice solamente un paño húmedo (humedecido con agua limpia o con un jabón suave). A continuación, utilice un paño seco. Evite el exceso de humedad.
* Evite uso de alcohol, hipoclorido solución basada, detergente y otros productos químicos, mismo diluídos en agua. No utilice productos abrasivos de ningún tipo.
ATTENTION!!!! assemblers and consumers
* To clean the furniture, use only a damp cloth (humidify it only in pure water or water and neutral soap). After, use a dry cloth. Avoid excessive humidity.
* Avoid using alcohol, bleach, detergent and other chemical products, even diluted in water. Do not use any kind of abrasive cleaning agents to clean the furniture.
The use of such products may jeopardize the ?nal characteristics of the furniture.

 60 min.
 1 montador
1 ajustador
1 Fitter

www.decibal.com.br



CO9104 - AÉREO 0,60M

Manual de Montagem
Assembly Instructions
Instrucción de Montaje

decibal[®]
móveis

Produto Montado
Producto final
Assembled

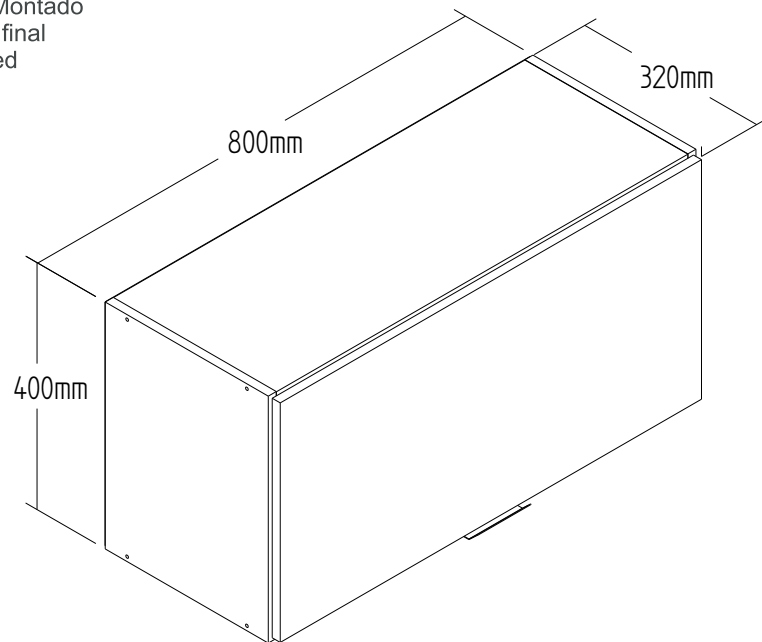

1º

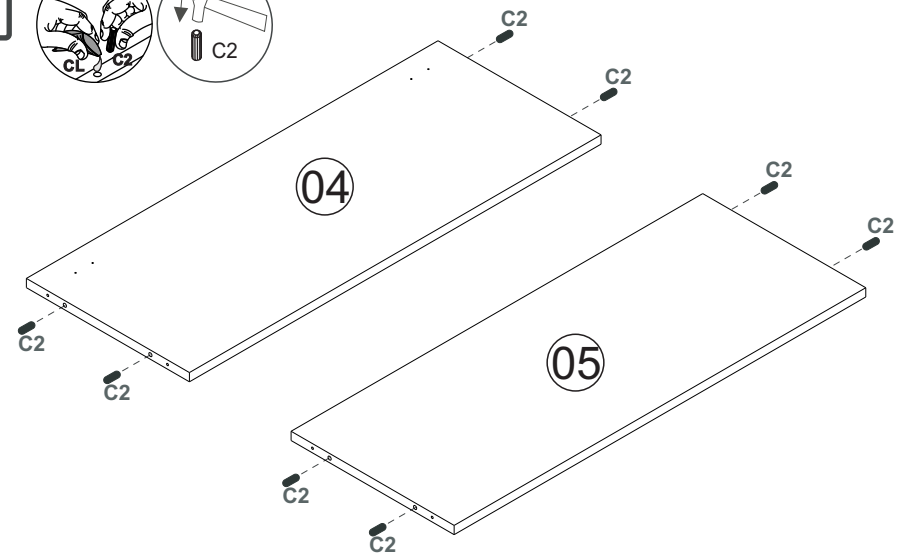
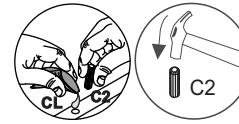

2º

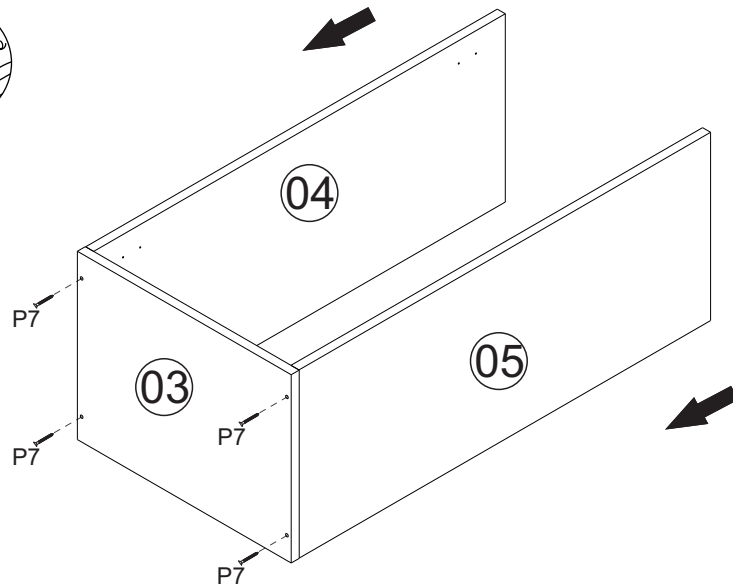

3º

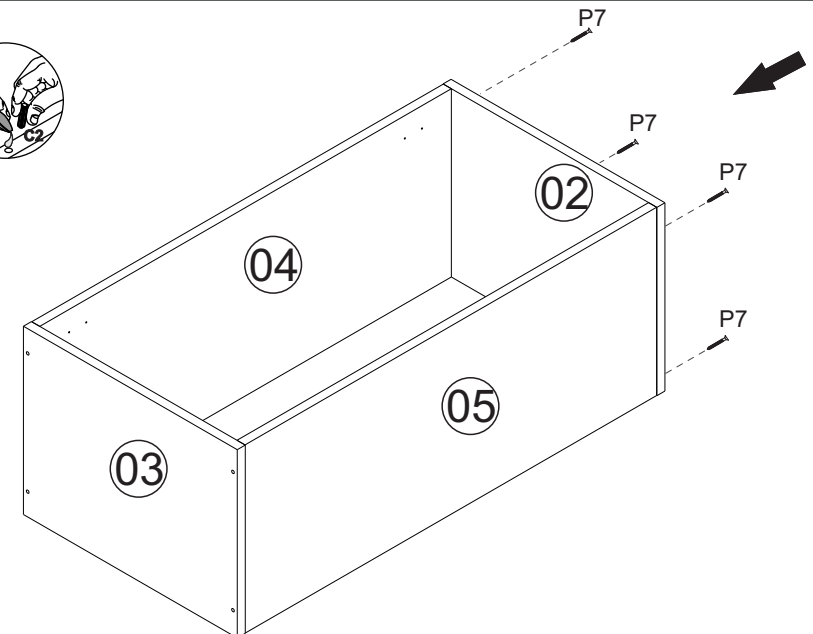

CO9104 - AÉREO 0,60M

Manual de Montagem
Assembly Instructions
Instrucción de Montaje

decibal[®]
móveis

4º COSTA/REVÉS/BACK

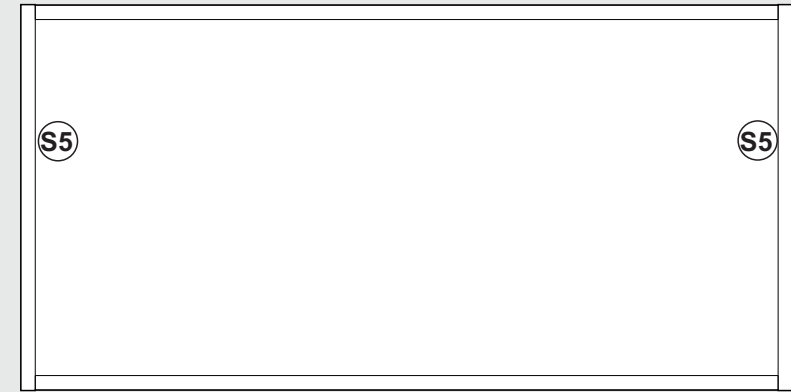
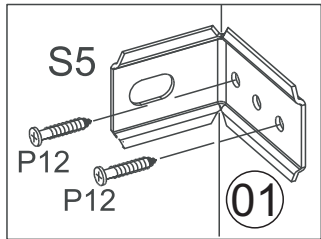
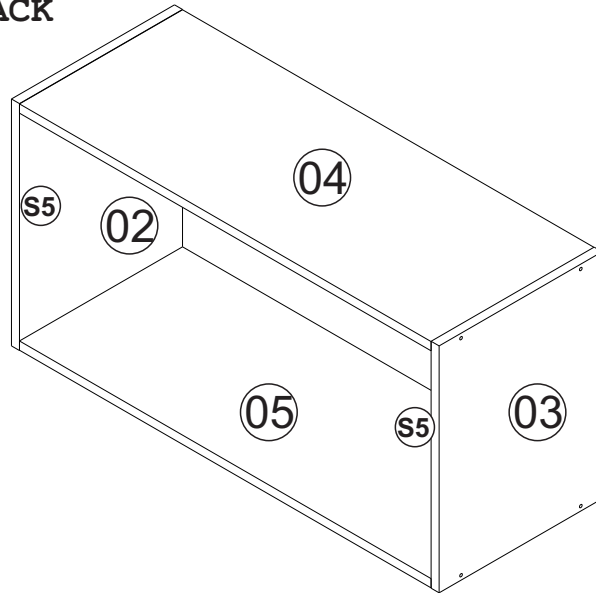

FIXAÇÃO NA PAREDE / FIJACIÓN EN LA PARED / FIXING ON THE WALL

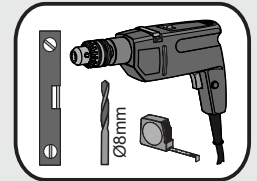
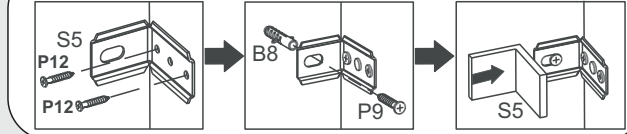

5º COSTA/REVÉS/BACK

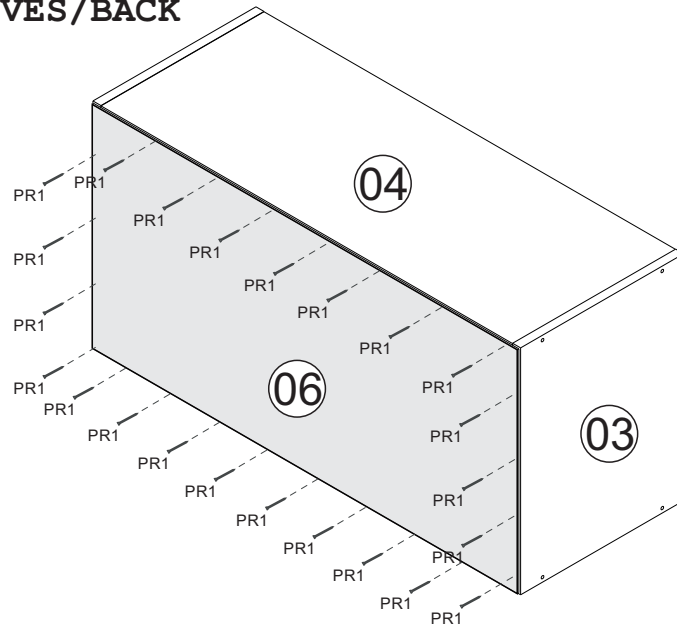
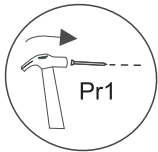

PESO SUPORTADO / PESO SOPORTADO / WEIGHT SUPPORTED

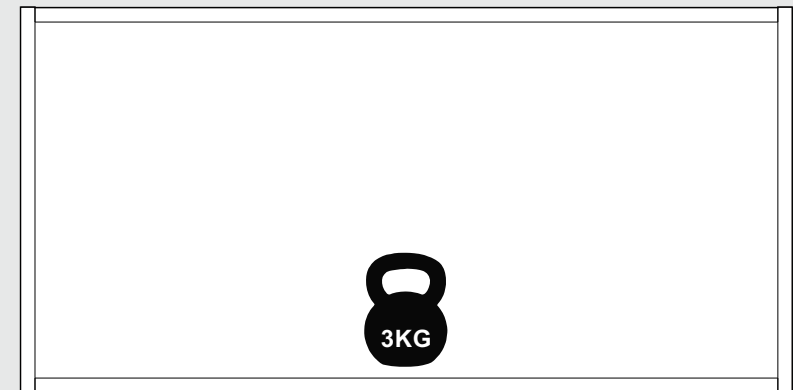

CO9104 - AÉREO 0,60M

Manual de Montagem
Assembly Instructions
Instrucción de Montaje

decibal[®]
móveis

6°

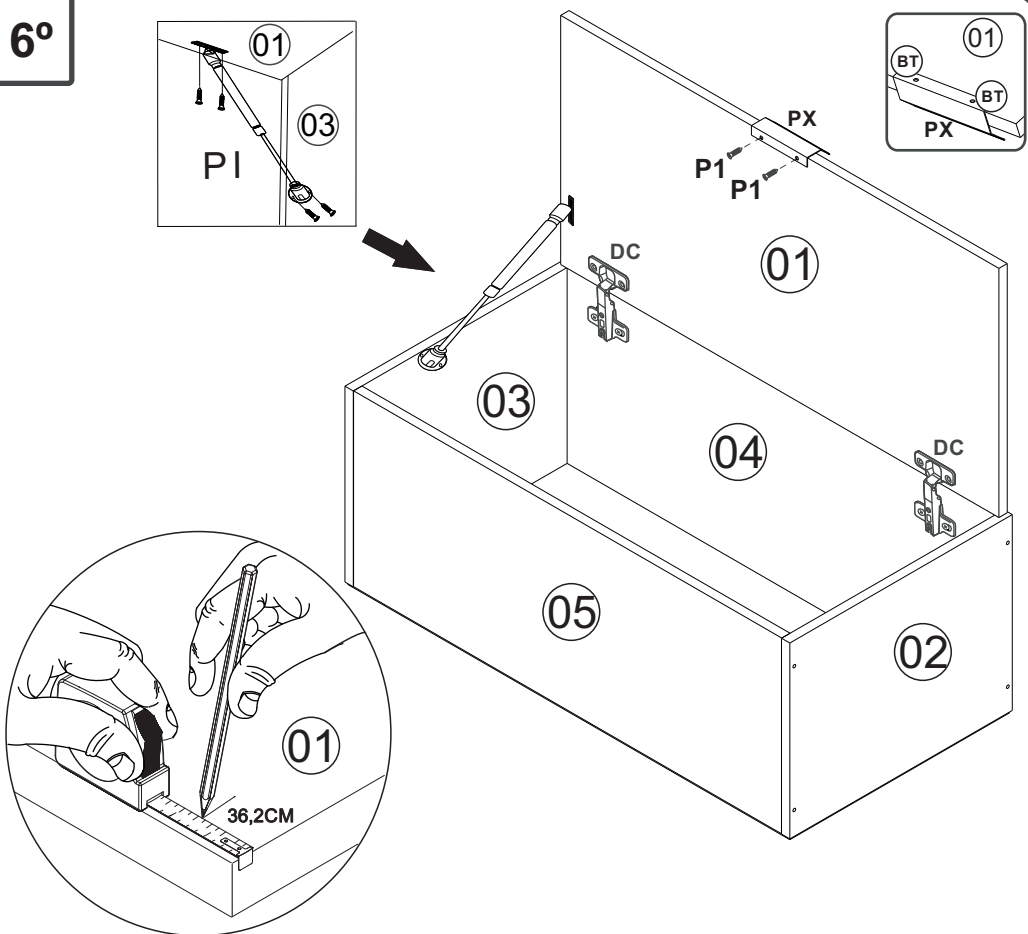

ATENÇÃO!!!!

MARCAÇÃO PRA O PRIMEIRO FURO DO PUXADOR

MARCADO PARA EL PRIMER AGUJERO

MARKING FOR THE FIRST HANDLE HOLE

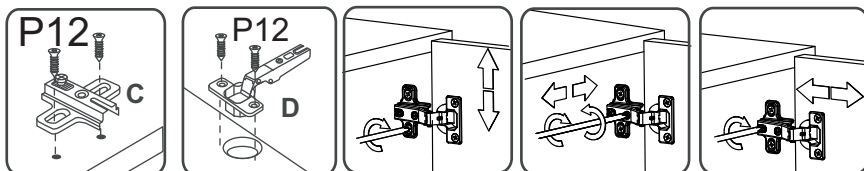

Relação de Peças/ Relación de Piezas/Parts List

N°	CÓDIGO/CODE	DESCRIÇÃO/DESCRIPCIÓN/DESCRIPTION	QTD/CANT	VOL.
1	0548658	PORTA/ PUERTA/DOOR	788X388X15MM	1
2	0548655	LATERAL DIR/LATERAL/SIDE	400X305X15MM	1
3	0549155	LATERAL ESQ/LATERAL/SIDE	400X305X15MM	1
4	0548656	BASE SUP	770X305X15MM	1
5	0548654	BASE INF	770X305X15MM	1
6	0548657	COSTA/REVÉS/BACK	796X396X2,8MM	1

www.decibal.com.br

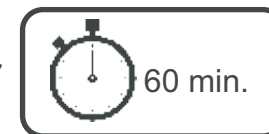

Ferramente necessárias
Necessary tools
Herramientas necesarias

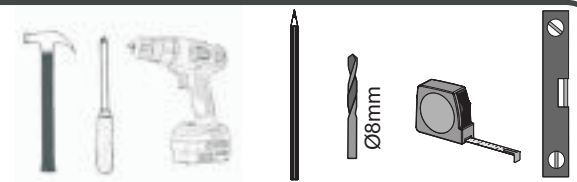

ATENÇÃO!!!! montadores e consumidores

* Para limpar o móveis utilize somente um pano úmido (umedecido em água pura ou água com sabão neutro). Depois, passe um pano seco. Evite a umidade excessiva.

* Evite usar álcool, água sanitária, detergente e outros produtos químicos, mesmo diluídos em água. Não utilize produtos abrasivos de nenhuma espécie

ATENCIÓN!!!! montadores e consumidores

* Para limpiar el mueble utilice solamente un paño húmedo (humedecido con agua limpia o con un jabón suave).

* Continúe, utilice un paño seco. Evite el exceso de humedad.

* Evite uso de alcohol, hipoclorídoro solución basada, detergente y otros productos químicos, mismo diluidos en agua. No utilice productos abrasivos de ningún tipo.







ATTENTION!!!! assemblers and consumers

* To clean the furniture, use only a damp cloth (humidify it only in pure water or water and neutral soap). After, use a dry cloth. Avoid excessive humidity.

* Avoid using alcohol, bleach, detergent and other chemical products, even diluted in water. Do not use any kind of abrasive cleaning agents to clean the furniture.









The use of such products may jeopardize the final characteristics of the furniture.

Ferragens/ Herrajes/ Hardware

LEGENDA	DESCRIÇÃO/DESCRIPCIÓN/DESCRIPTION	CÓDIGO	QUANT.
P7	 PARAFUSO/TORNILLO/SCREW 4X45	01318	08
PR1	 PREGO/CLAVO/NAIL 10X10	01330	38
C2	 CAVILHA/TARUGO/DOWEL 6X30 MM	01211	10
P1	 PARAFUSO/TORNILLO/SCREW 3,5X12	01328	02
PU	 PARAFUSO UNIÃO/UNIÓN DETORNILLO /SCREW UNION	01495	02
P12	 PARAFUSO/TORNILLO/SCREW 3,5X13	09927	12
P9	 PARAFUSO/TORNILLO/SCREW 6X50	03827	02

escala (1:1)

escala (N/A)

LEGENDA	DESCRIÇÃO/DESCRIPCIÓN/DESCRIPTION	CÓDIGO	QUANT.
CL	 COLA/PEGAMENTO/GLUE	01213	01
ET	 ETIQUETA LOGO DECIBAL/LABEL DECIBAL	01312	01
B1	 BUCHA/BUJE/BUCHING (8mm)	01311	02
DC	 DOBRADIÇA/BISAGRA/HINGE D=35mm C=0mm	09449	02
S5	 SUPORTE AÉREO/APOYO AÉREO/AIR SUPPORT EBANO 04501	03828	02
PI	 PISTÃO GÁS / PISTÓN DE GAS /GAS PISTON 80N	01265	01
AD	 ADESIVO/ADHESIVO/ADHESIVE NATURALLE 09963		08
BT	 BATENTE/BATIENTE DE SILICONA/SILICONE STOP 8MM	02921	02
PX	 PUXADOR/PEGADOR /HANDLE (MOV410 /100MM)	11440	01

ATENÇÃO!!!! montadores e consumidores
* Ajustar o torque da parafusadeira para não danificar as peças escareando o parafuso *

ATENCIÓN!!!! montadores e consumidores
* Ajuste el torque del destornillador para no dañar las piezas avallanando el tornillo *

ATTENTION!!!! assemblers and consumers
* Adjust the torque of the screwdriver so as not to damage the parts by countersinking the screw *

Medida em mm



CO9203 - BALCÃO 0,80 M

Manual de Montagem
Assembly Instructions
Instrucción de Montaje

decibal[®]
móveis

Produto Montado
Producto final
Assembled

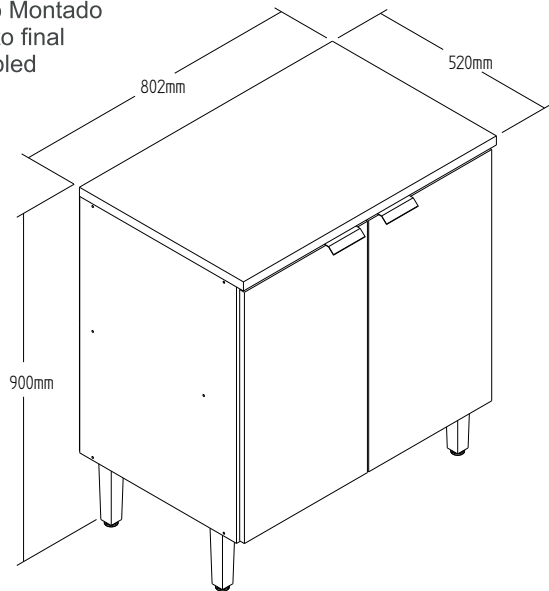

01°

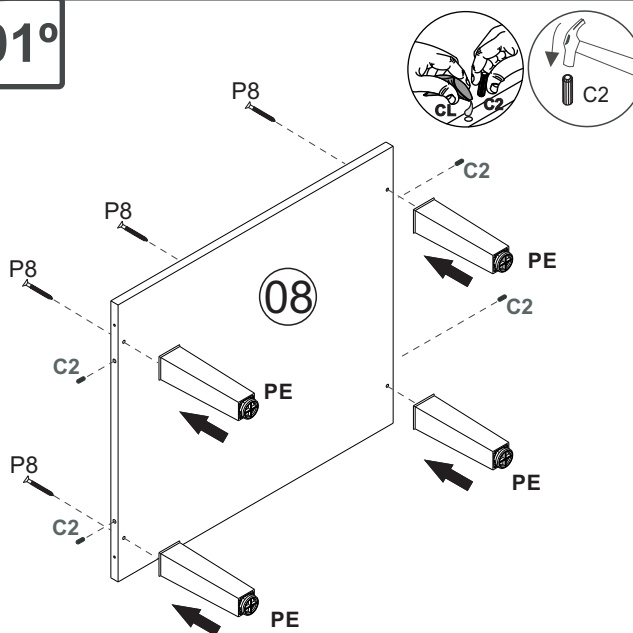

02°

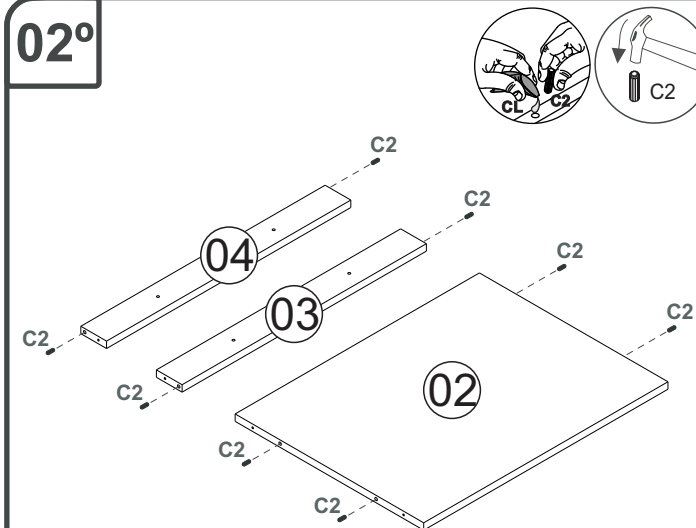

03°

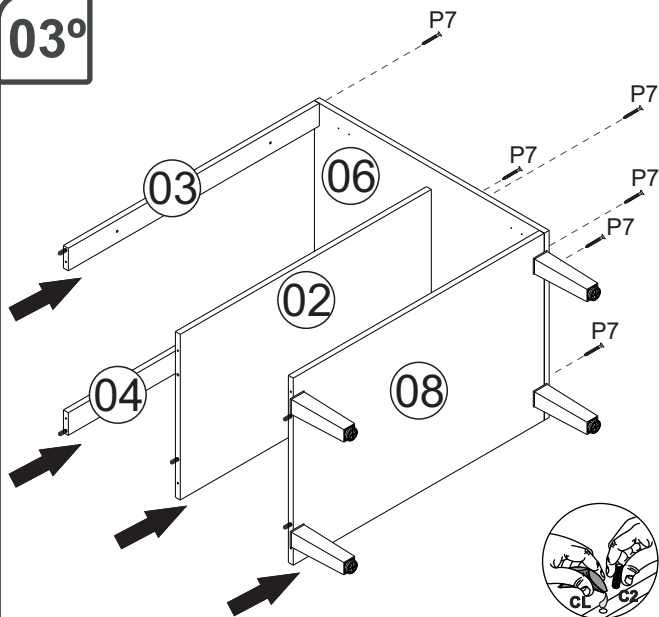

04°

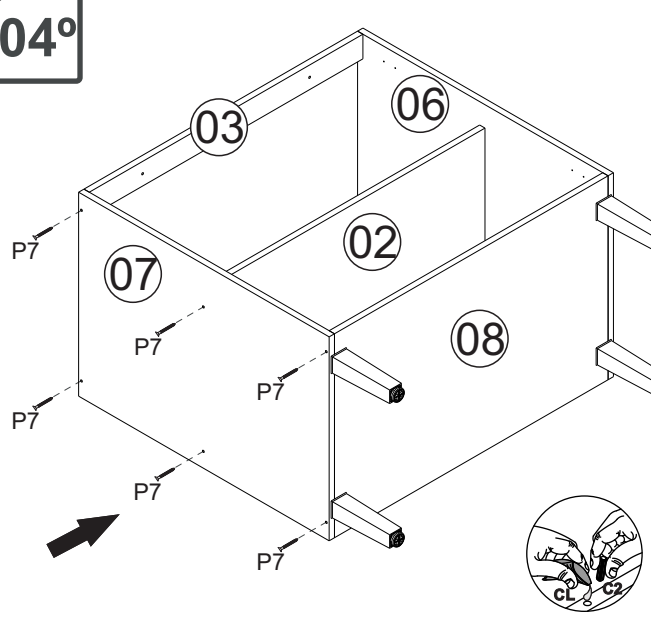

PESO SUPORTADO/PESO SOPORTADO/WEIGHT SUPPORTED



CO9203 - BALCÃO 0,80 M

Manual de Montagem
Assembly Instructions
Instrucción de Montaje

decibal[®]
móveis

07°

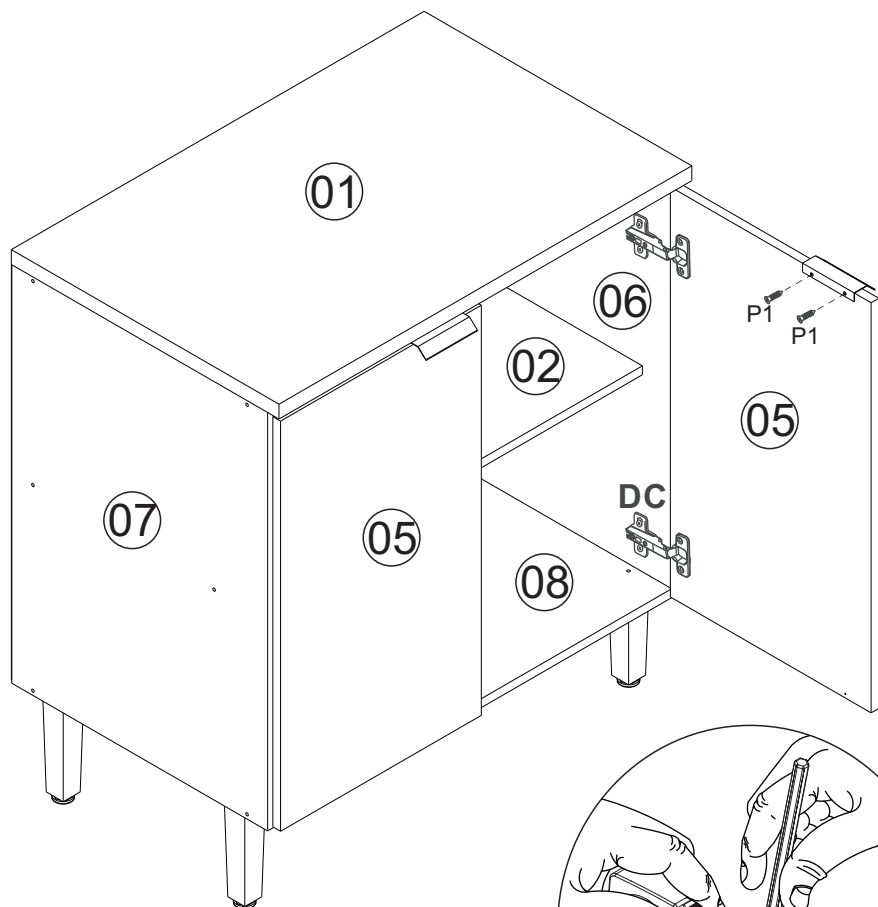
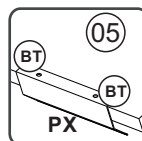
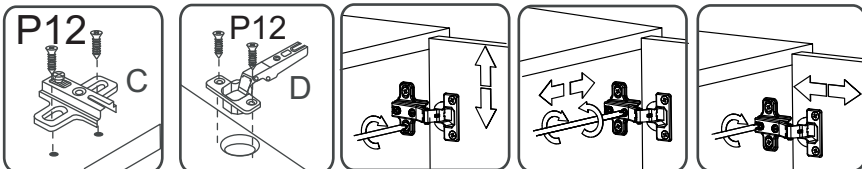

ATENÇÃO!!!!

MARCAÇÃO PRA O PRIMEIRO FURO DO PUXADOR

MARCADO PARA EL PRIMER AGUJERO

MARKING FOR THE FIRST HANDLE HOLE

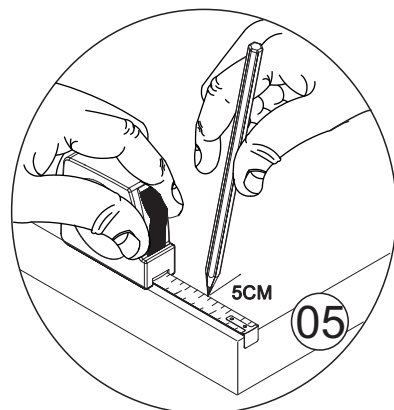

Relação de Peças/ Relación de Piezas/Parts List

N°	CÓDIGO/CODE	DESCRIÇÃO/DESCRIPCIÓN/DESCRIPTION	QTD/CANT	VOL.
1	0548708	TAMPO/TAPA/TOP	802X520X25MM	1
2	0548712	PRATELERIA/ESTANTE/SHELF	770X440X15MM	1
3	0548714	TRAVESSA FRT/TRAVIESA/TRVERSE	770X60X15MM	1
4	0548715	TRAVESSA TRS/TRAVIESA/TRVERSE	770X60X15MM	1
5	0548711	PORTA/PUERTA/DOOR	690X390X15MM	2
6	0548709	LATERAL DIR/LATERAL/SIDE	705X497X15MM	1
7	0548707	LATERAL ESQ/LATERAL/SIDE	705X497X15MM	1
8	0548710	BASE	770X497X15MM	1
9	0548713	COSTA/REVÉS/BACK	796X350X2,8MM	2

www.decibal.com.br

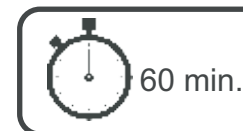

ATENÇÃO!!!! montadores e consumidores
* Ajustar o torque da parafusadeira para não danificar as peças escareando o parafuso *

ATENCIÓN!!!! montadores e consumidores
* Ajuste el torque del destornillador para no dañar las piezas avallando el tornillo *

ATTENTION!!!! assemblers and consumers
* Adjust the torque of the screwdriver so as not to damage the parts by countersinking the screw *

Ferramenta necessárias
Necessary tools
Herramientas necesarias

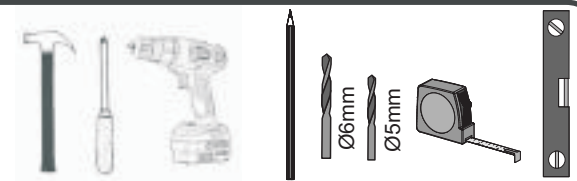

ATENÇÃO!!!! montadores e consumidores
* Para limpar o móveis utilize somente um pano úmido (umedecido em água pura ou água com sabão neutro). Depois, passe um pano seco. Evite a umidade excessiva.
* Evite usar álcool, água sanitária, detergente e outros produtos químicos, mesmo diluídos em água. Não utilize produtos abrasivos de nenhuma espécie

ATENCIÓN!!!! montadores e consumidores
* Para limpiar el mueble utilice solamente un paño húmedo (humedecido con agua limpia o con un jabón suave). A continuación, utilice un paño seco. Evite el exceso de humedad.
* Evite uso de alcohol, hipoclorídoro solución basada, detergente y otros productos químicos, mismo diluídos en agua. No utilice productos abrasivos de ningún tipo.









ATTENTION!!!! assemblers and consumers
* To clean the furniture, use only a damp cloth (humidify it only in pure water ou water and neutral soap).After, use a dry cloth.Avoid excessive humidity.
* Avoid using alcohol, bleach, detergent and other chemical products, even diluted in water. Do not use any kind of abrasive cleaning agents to clean the furniture.
The use of such products may jeopardize the ?nal characteristics of the furniture.

CO9203 - BALCÃO 0,80 M









Manual de Montagem
Assembly Instructions
Instrucción de Montaje

decibal[®]
móveis

escala (1:1)

LEGENDA	DESCRIÇÃO/DESCRIPCIÓN/DESCRIPTION	CÓDIGO	QUANT.
P7	 PARAFUSO/TORNILLO/SCREW 4X45	01318	12
P1	 PARAFUSO/TORNILLO/SCREW 3,5X12	01328	04
Pr1	 PREGO/CLAVO/NAIL 10X10	01330	40
C2	 CAVILHA/TARUGO/DOWEL 6X30 MM	01211	13
PU	 PARAFUSO UNIÃO/UNIÓN DETORNILLO /SCREW UNION	01495	02
P12	 PARAFUSO/TORNILLO/SCREW 3,5X13	09927	24
P8	 PARAFUSO/TORNILLO/SCREW 5X45	01320	04
P5	 PARAFUSO/TORNILLO/SCREW 4X25	01317	04

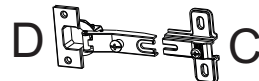
escala (N/A)

LEGENDA	DESCRIÇÃO/DESCRIPCIÓN/DESCRIPTION	CÓDIGO	QUANT.
CL	 COLA/PEGAMENTO/GLUE	01213	01
PX	 PUXADOR/PEGADOR /HANDLE (MOV410 /100MM)	11440	02
ET	 ETIQUETA LOGO DECIBAL/LABEL DECIBAL	01312	01
Ct1	 CANTONEIRA/PIEZA L/SHEET	03077	04
FX	 FIXADOR COSTA/FIJADOR FONDO/FIXER COAST	01331	06
PE	 PÉ/PATA/FOOT (170mm) CINZA170mm	11121	04
DC	 DOBRADIÇA/BISAGRA/HINGE D=35mm C=0mm	09449	04
AD	 ADESIVO /ADHESIVO /ADHESIVE	Griseo 11895	12
BT	 BATENTE/BATIENTE DE SILICONA/SILICONE STOP 8MM	02921	04

Medida em mm



CO9210- PANELEIRO

Manual de Montagem
Assembly Instructions
Instrucción de Montaje

decibal[®]
móveis

06°

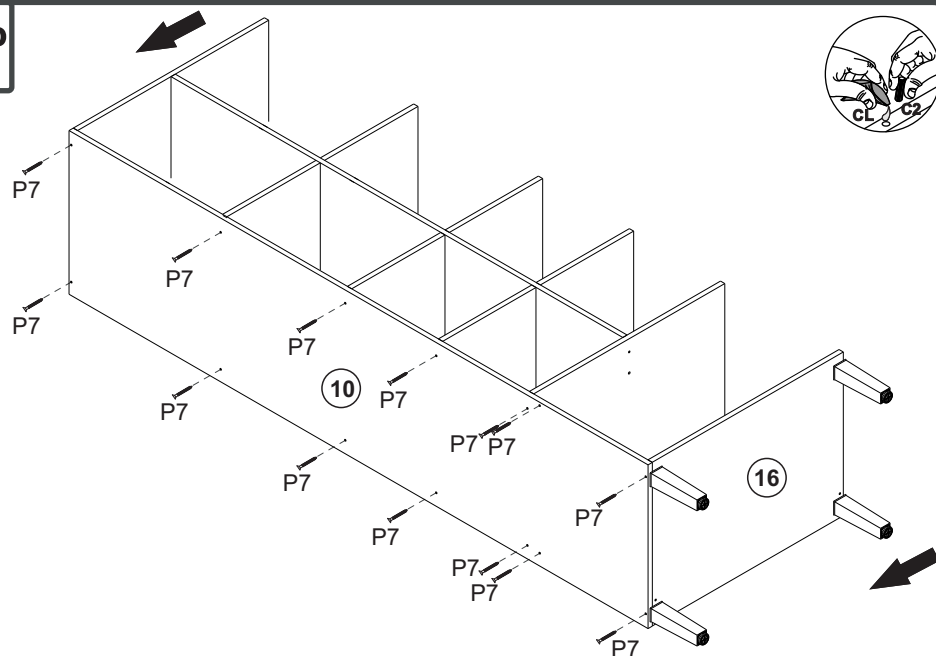

07°

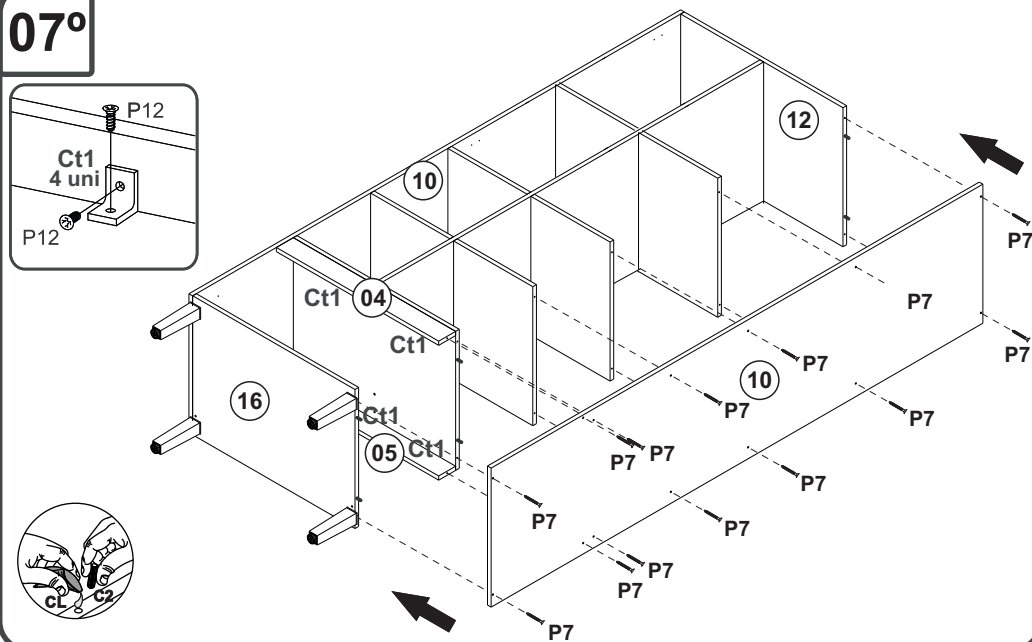

08°

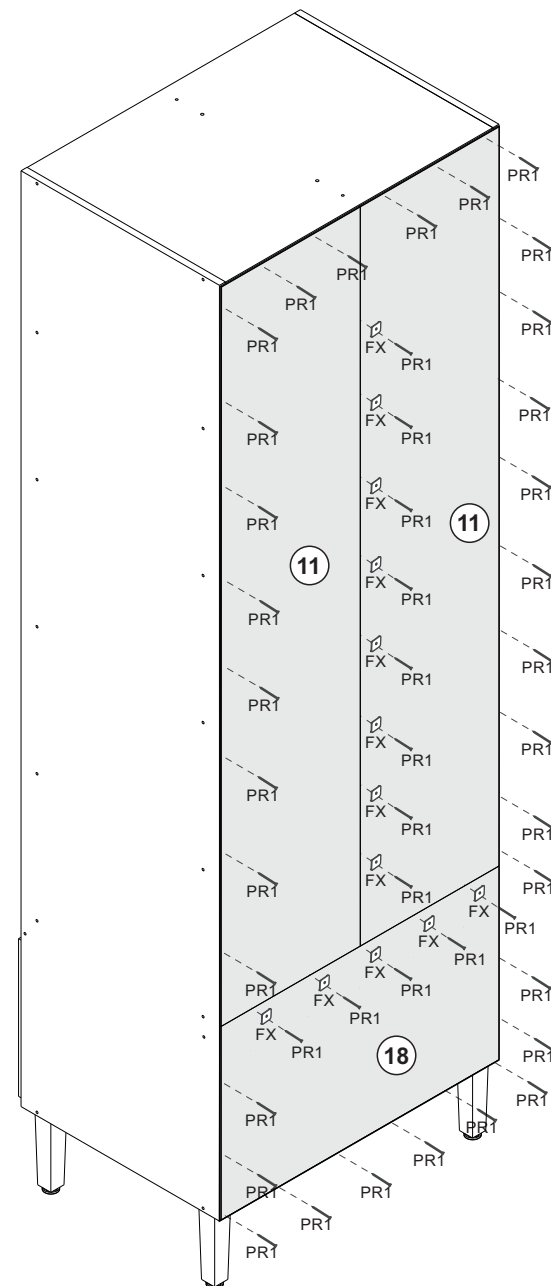

CO9210- PANELEIRO

Manual de Montagem
Assembly Instructions
Instrucción de Montaje

decibal[®]
móveis

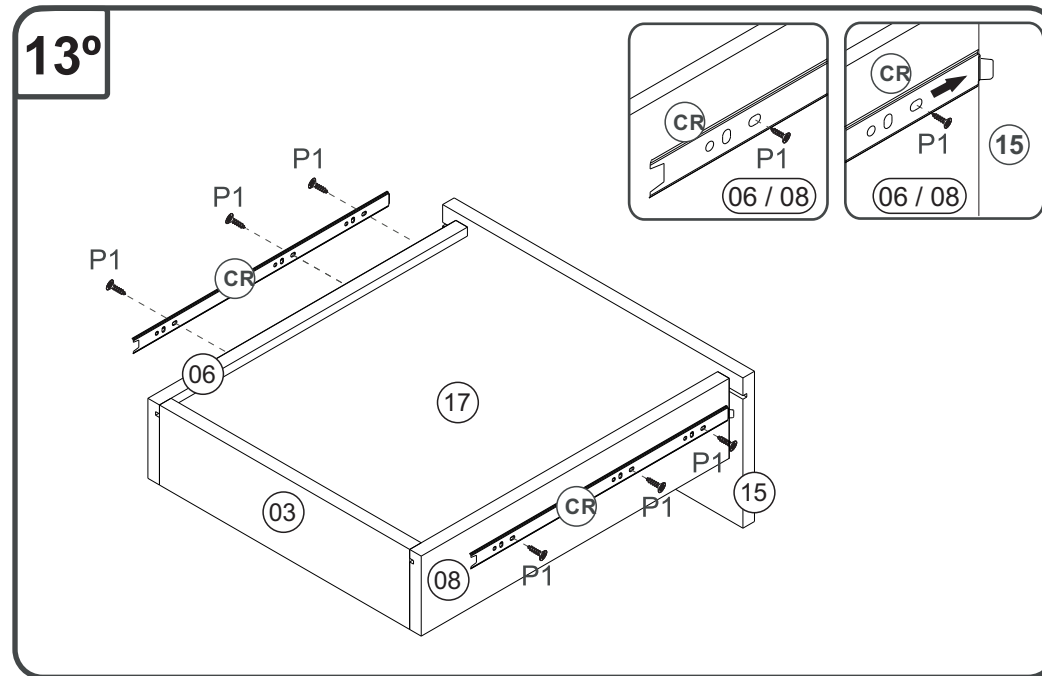
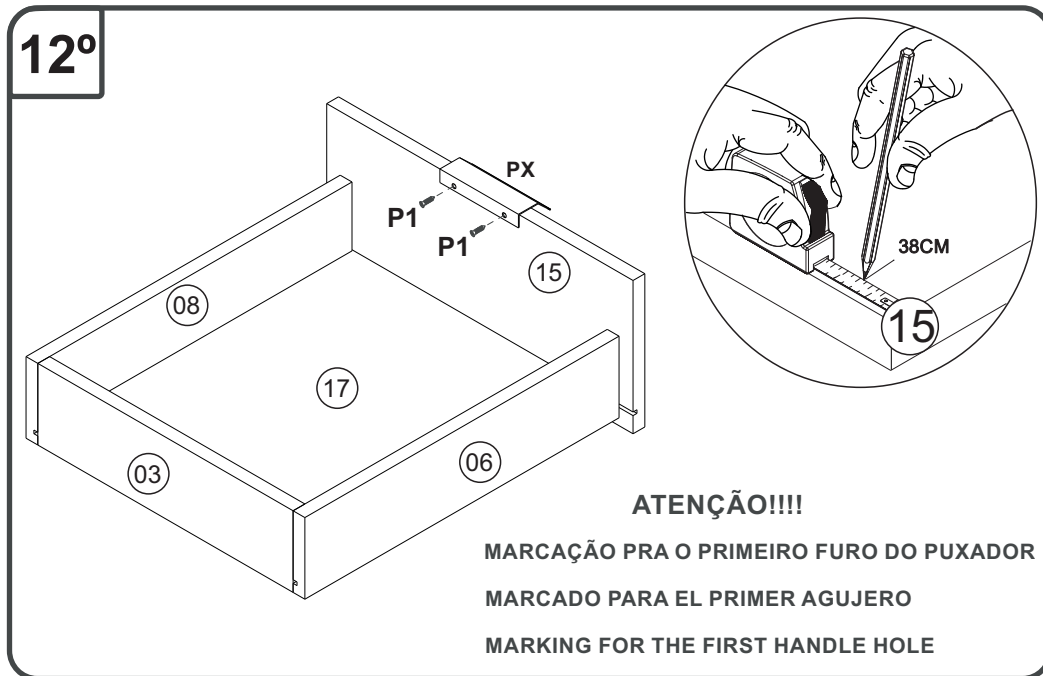
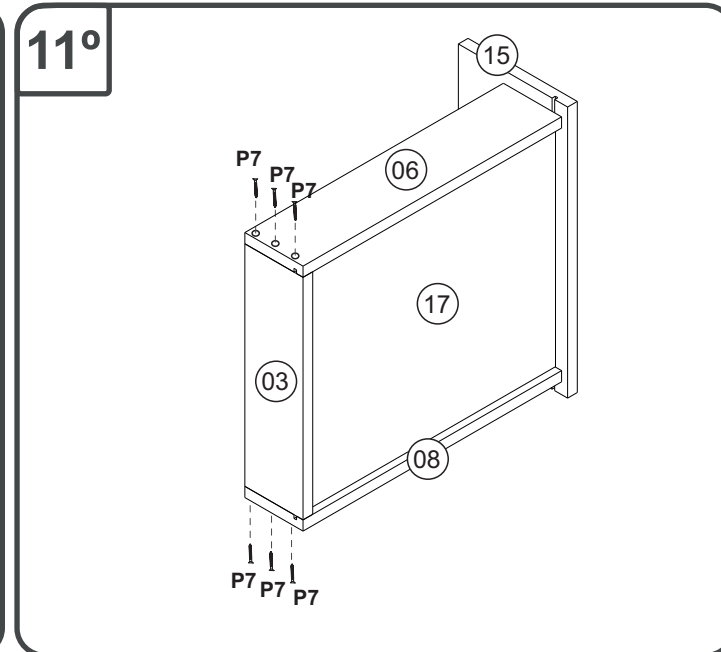
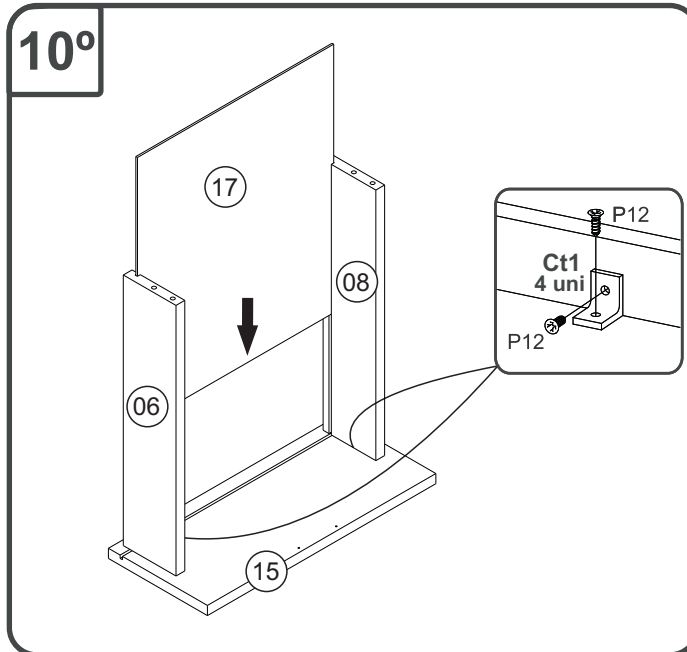
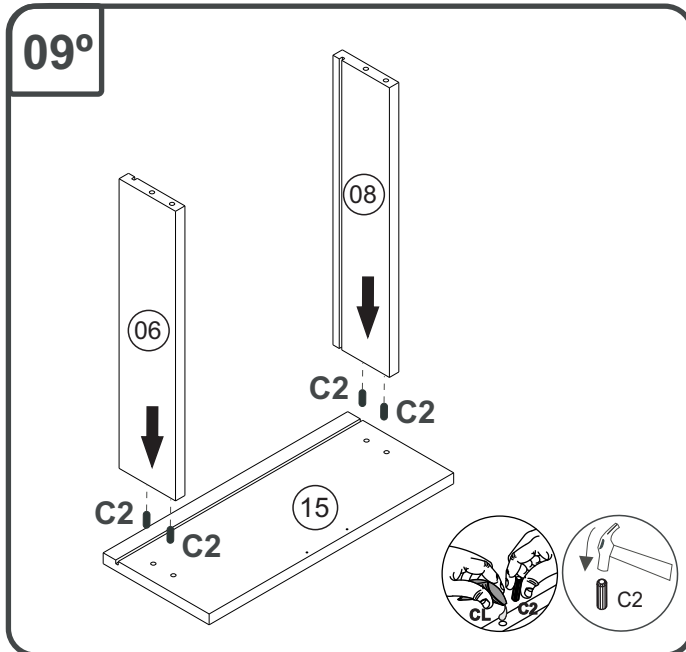

CO9210- PANELEIRO

Manual de Montagem
 Assembly Instructions
 Instrucción de Montaje



14°

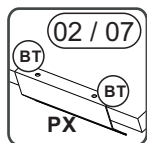
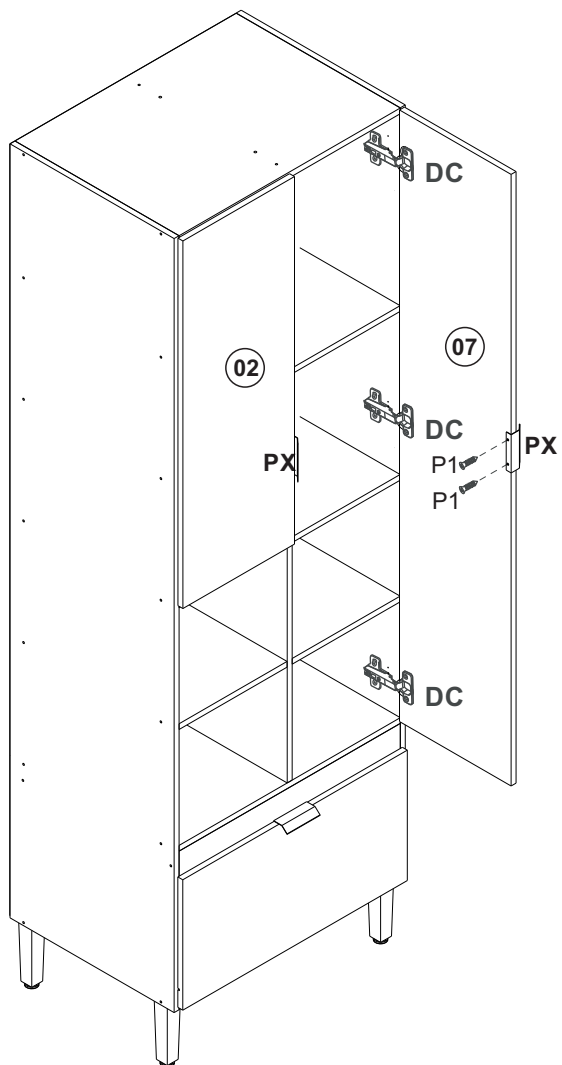
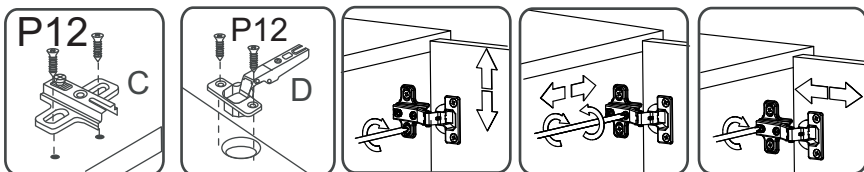

PESO SUPORTADO/PESO SOPORTADO/WEIGHT SUPPORTED

Fixação parede
 Fixed in the wall

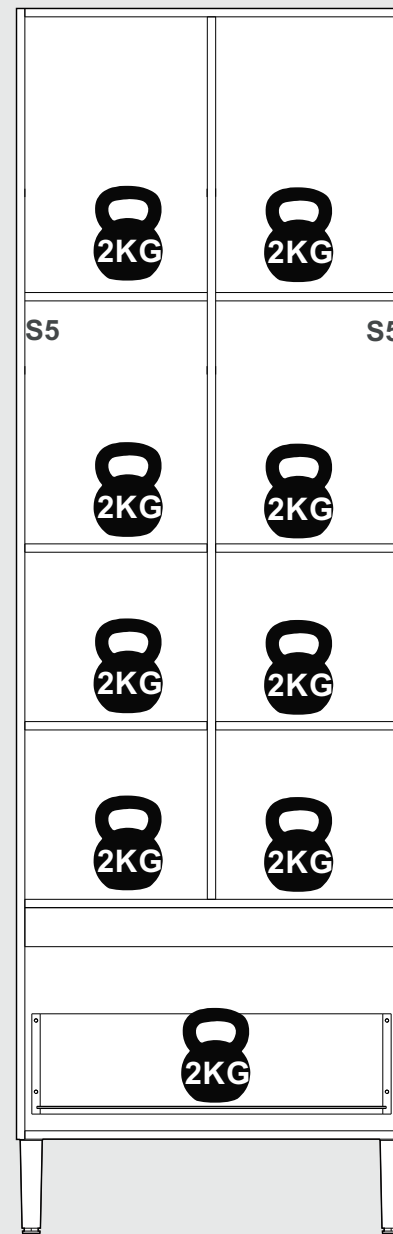
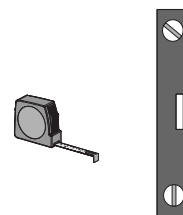
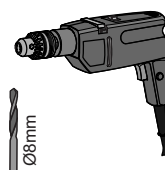
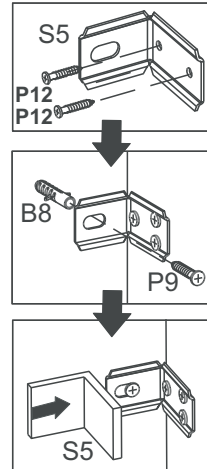

CO9210- PANELEIRO

Manual de Montagem
Assembly Instructions
Instrucción de Montaje

decibal[®]
móveis

Relação de Peças/ Relación de Piezas/Parts List

Nº	CÓDIGO/CODE	DESCRIÇÃO/DESCRIPCIÓN/DESCRIPTION	QTD/CANT	VOL.
1	0548730	LATERAL DIR/LATERAL/SIDE	2030X497X15MM	1 1
2	0548741	PORTA/PUERTA/DOOR	964X338X15MM	1 1
3	0548746	BATENTE/REVÉS CAJÓN/DRAWER BACK	615X180X15MM	1 1
4	0548742	TRAVESSA FRT/TRAVIESA/TRVERSE	670X70X15MM	1 1
5	0548743	TRAVESSA TRS/TRAVIESA/TRVERSE	670X70X15MM	1 1
6	0548936	LATERAL DE GAVETA/LATERAL CAJÓN DRAWER SIDE (ESQ)	400X180X15MM	1 1
7	0548740	PORTA/PUERTA/DOOR	1604X338X15MM	1 1
8	0548745	LATERAL DE GAVETA/LATERAL CAJÓN DRAWER SIDE (DIR)	400X180X15MM	1 1
9	0548734	DIVISÓRIA/DIVIDER	1584X497X15MM	1 1
10	0549731	LATERAL ESQ/LATERAL/SIDE	2030X497X15MM	1 1
11	0548736	COSTA/REVÉS/BACK	1604X348X2, 8MM	2 1
12	0548733	BASE SUP	670X497X15MM	1 2
13	0548732	BASE MEIO	670X497X15MM	1 2
14	0548739	PRATELERIA/ESTANTE/SHELF	497X327X15MM	6 2
15	0548687	FRENTE DE GAVETA/FRENTE CÁJON DRAWER FRONT	680X342X15MM	1 2
16	0548729	BASE INF	670X497X15MM	1 2
17	0548747	FUNDO GAVETA/FONDO CAJÓN/ DRAWER BOTTOM	627X395X2, 8MM	1 2
18	0548735	COSTA/REVÉS/BACK	696X420X2, 8MM	1 2

Ferramenta necessárias
Necessary tools
Herramientas necesarias

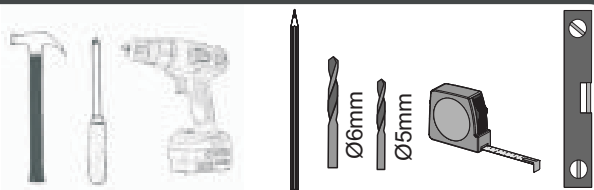

ATENÇÃO!!!! montadores e consumidores

* Ajustar o torque da parafusadeira para não danificar as peças escareando o parafuso *

ATENCIÓN!!!! montadores e consumidores

* Ajuste el torque del destornillador para no dañar las piezas avallanando el tornillo *

ATTENTION!!!! assemblers and consumers

* Adjust the torque of the screwdriver so as not to damage the parts by countersinking the screw *

escala (1:1)

LEGENDA	DESCRIÇÃO/DESCRIPCIÓN/DESCRIPTION	CÓDIGO	QUANT.
P9	 PARAFUSO/TORNILLO/SCREW 6X50	03827	02

escala (N/A)

LEGENDA	DESCRIÇÃO/DESCRIPCIÓN/DESCRIPTION	CÓDIGO	QUANT.
B1	 BUCHA/BUJE/BUCHING	01311	02
S5	 SUPORTE AÉREO/APOYO AÉREO/AIR SUPPORT	03828 EBANO 04501	02

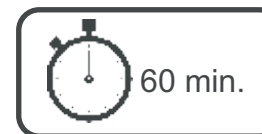

www.decibal.com.br

ATENÇÃO!!!! montadores e consumidores

* Para limpar o móveis utilize somente um pano úmido (umedecido em água pura ou água com sabão neutro). Depois, passe um pano seco. Evite a umidade excessiva.

* Evite usar álcool, água sanitária, detergente e outros produtos químicos, mesmo diluídos em água. Não utilize produtos abrasivos de nenhuma espécie

ATENCIÓN!!!! montadores e consumidores

* Para limpiar el mueble utilice solamente un paño húmedo (humedecido con agua limpia o con un jabón suave). A continuación, utilice un paño seco. Evite el exceso de humedad.

* Evite uso de alcohol, hipocloridoro solución basada, detergente y otros productos químicos, mismo diluídos en agua. No utilice productos abrasivos de ningún tipo.

ATTENTION!!!! assemblers and consumers

* To clean the furniture, use only a damp cloth (humidify it only in pure water ou water and neutral soap).After, use a dry cloth.Avoid excessive humidity.

*Avoid using alcohol, bleach, detergent and other chemical products, even diluted in water. Do not use any kind of abrasive cleaning agents to clean the furniture.



The use of such products may jeopardize the ?nal characteristics of the furniture.

CO9210- PANELEIRO









Manual de Montagem
Assembly Instructions
Instrucción de Montaje

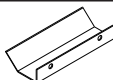

escala (1:1)

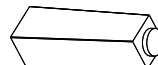
LEGENDA	DESCRIÇÃO/DESCRIPCIÓN/DESCRIPTION	CÓDIGO	QUANT.
P7	 PARAFUSO/TORNILLO/SCREW 4X45	01318	44
P1	 PARAFUSO/TORNILLO/SCREW 3,5X12	01328	18
Pr1	 PREGO/CLAVO/NAIL 10X10	01330	80
C2	 CAVILHA/TARUGO/DOWEL 6X30 MM	01211	22
PU	 PARAFUSO UNIÃO/UNIÓN DETORNILLO /SCREW UNION	01495	02
P12	 PARAFUSO/TORNILLO/SCREW 3,5X13	09927	40
P8	 PARAFUSO/TORNILLO/SCREW 5X45	01320	04
C3	 CAVILHA/TARUGO/DOWEL 6X50 MM	01212	09

escala (N/A)

LEGENDA	DESCRIÇÃO/DESCRIPCIÓN/DESCRIPTION	CÓDIGO	QUANT.
CL	 COLA/PEGAMENTO/GLUE	01213	02
PX	 PUXADOR/PEGADOR /HANDLE (MOV410 /100MM)	11440	03
ET	 ETIQUETA LOGO DECIBAL/LABEL DECIBAL	01312	01
Ct1	 CANTONEIRA/PIEZA L/SHEET	03077	08
FX	 FIXADOR COSTA/FIJADOR FONDO/FIXER COAST	01331	18
PE	 PÉ/PATA/FOOT CINZA 170mm	11121	04
CR	 CORREDICA/CORREDERA/METALIC SLIDE LARG	02641	01
AD	 ADESIVO/ADHESIVO/ADHESIVE Griseo 11895		32
DC	 DOBRADIÇA/BISAGRA/HINGE D=35mm C=0mm	09449	05
BT	 BATENTE/BATIENTE DE SILICONA/SILICONE STOP 8MM	02921	06

Medida em mm



CO9320 - BALCÃO 1,20 M

Manual de Montagem
 Assembly Instructions
 Instrucción de Montaje



Produto Montado
 Producto final
 Assembled

Direita
 Right
 Derecha

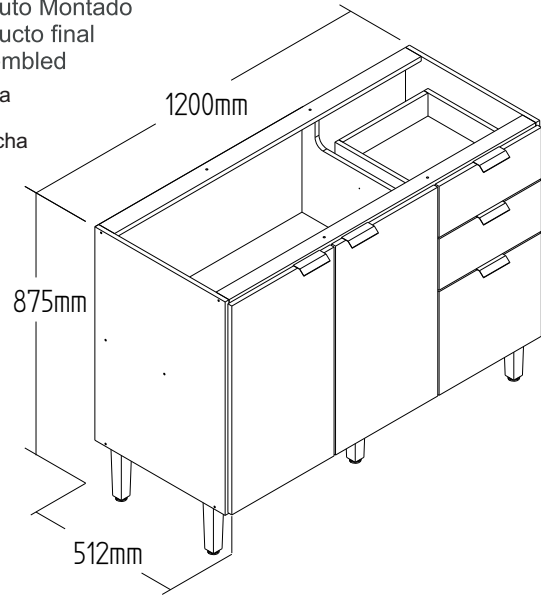

Produto Montado
 Producto final
 Assembled

Esquerdo
 left
 Izquierda

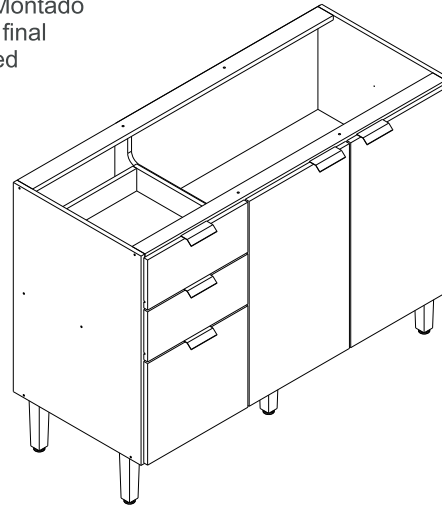

Possibilidade de montagem esquerda e direita
 Posibilidad de montaje izquierdo y derecho
 Possibility of left and right mounting

1º

Direita
 Right
 Derecha

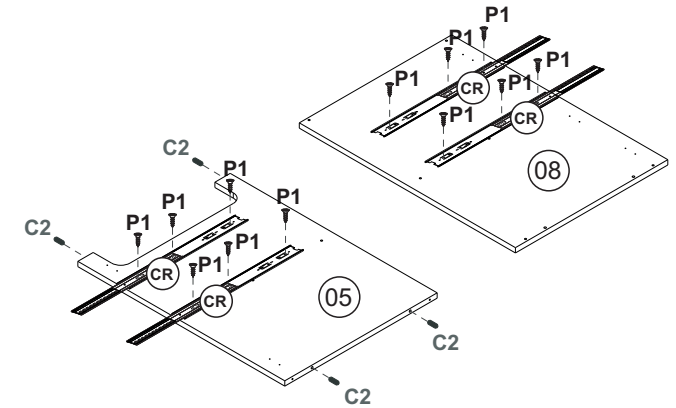
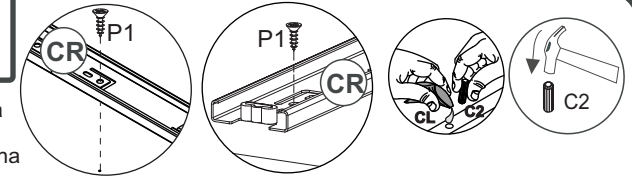

2º

Esquerdo
 left
 Izquierda

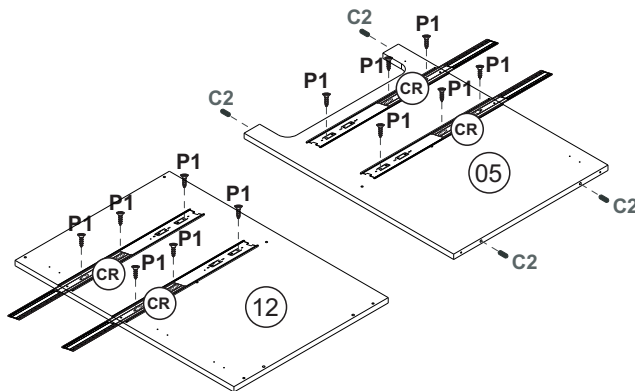
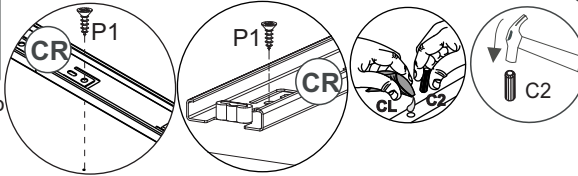

3º

Direita
 Right
 Derecha

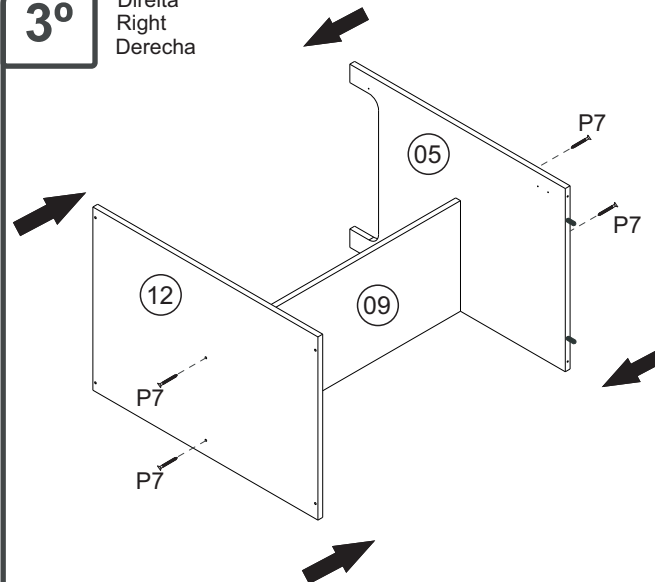

4º

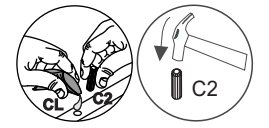
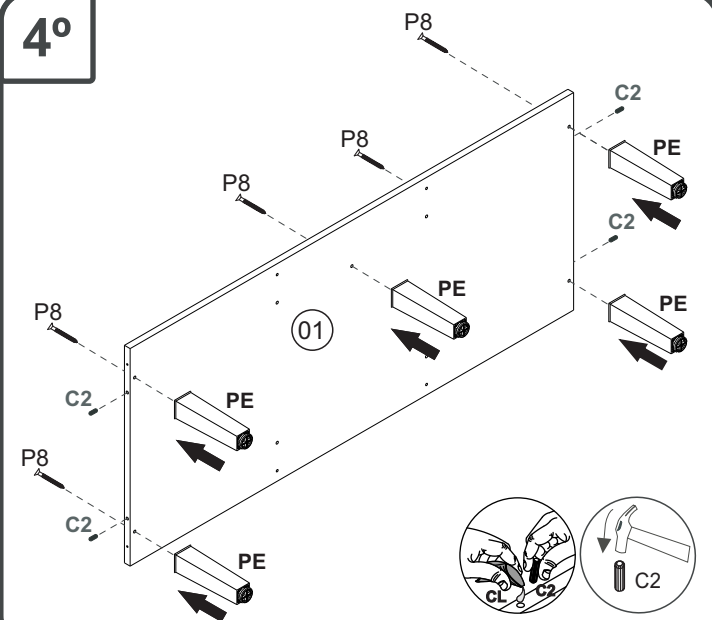

CO9320 - BALCÃO 1,20 M

Manual de Montagem
 Assembly Instructions
 Instrucción de Montaje

decibal[®]
 móveis

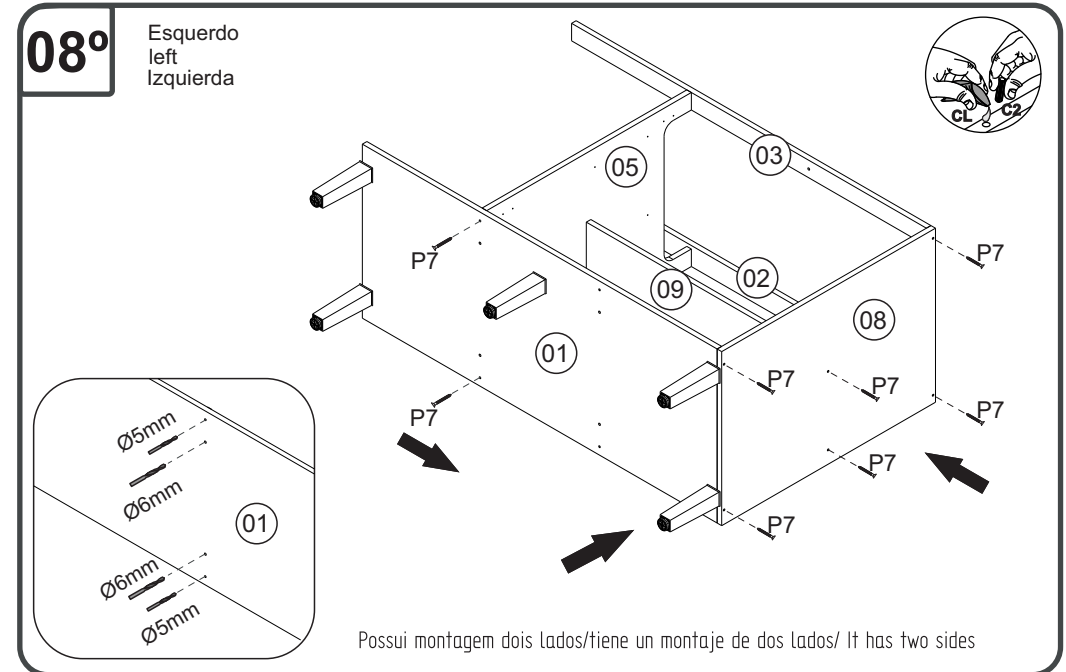
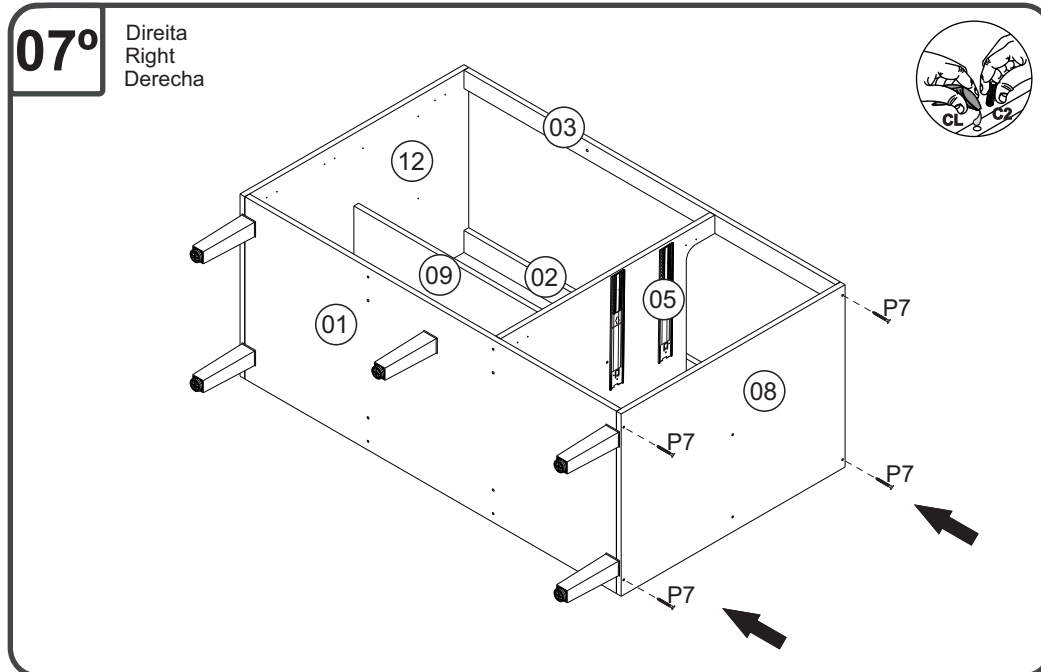
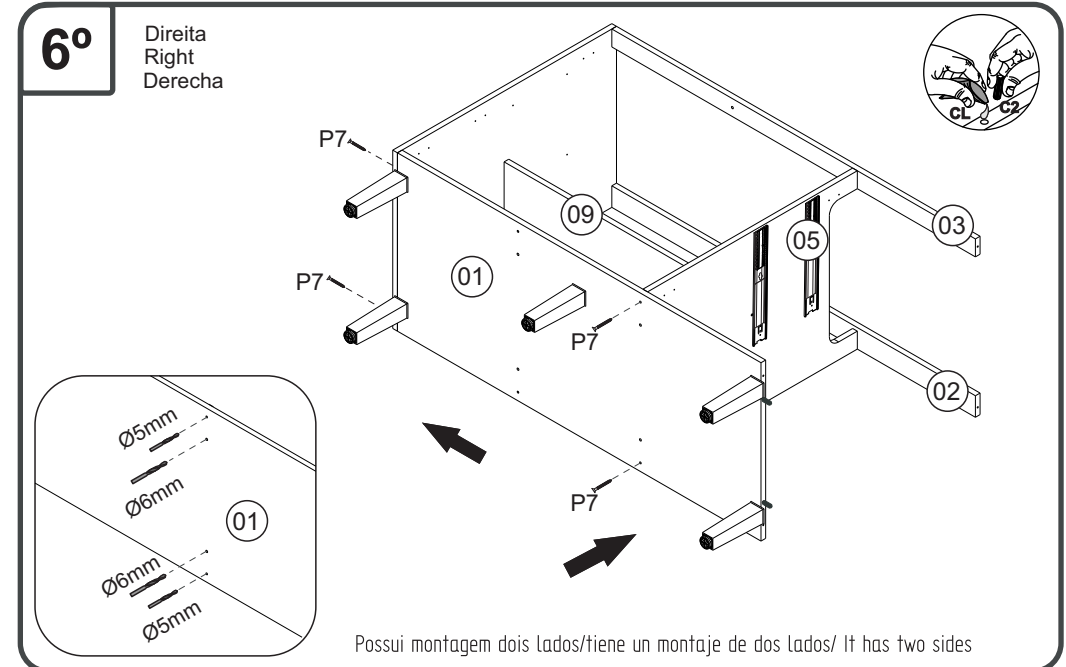
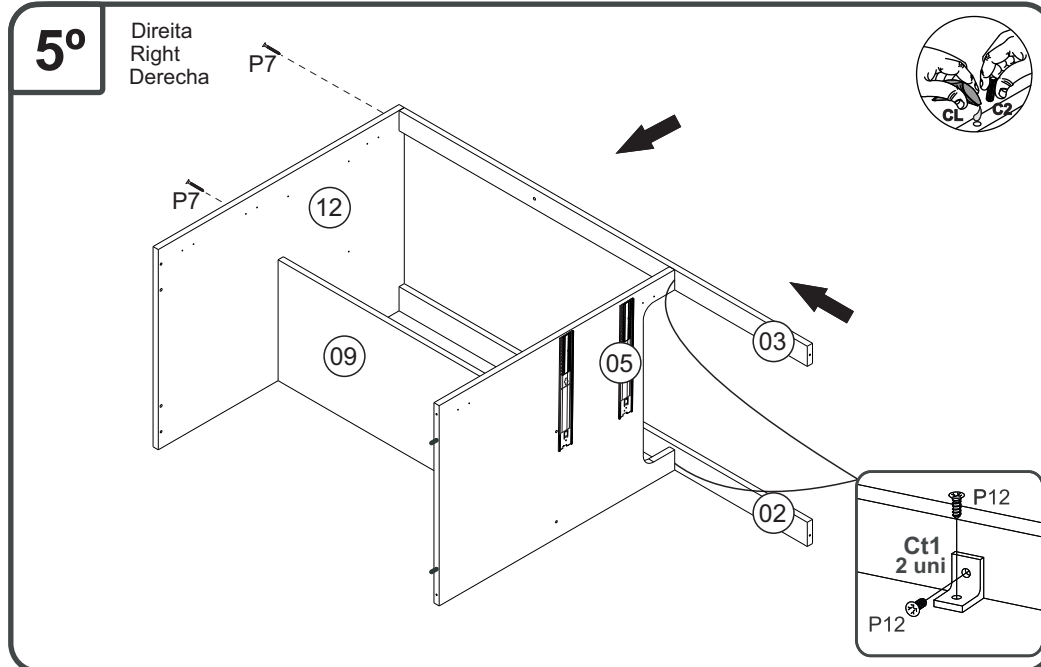

CO9320 - BALCÃO 1,20 M

Manual de Montagem
 Assembly Instructions
 Instrucción de Montaje



09°

Esquerdo
 left
 Izquierda

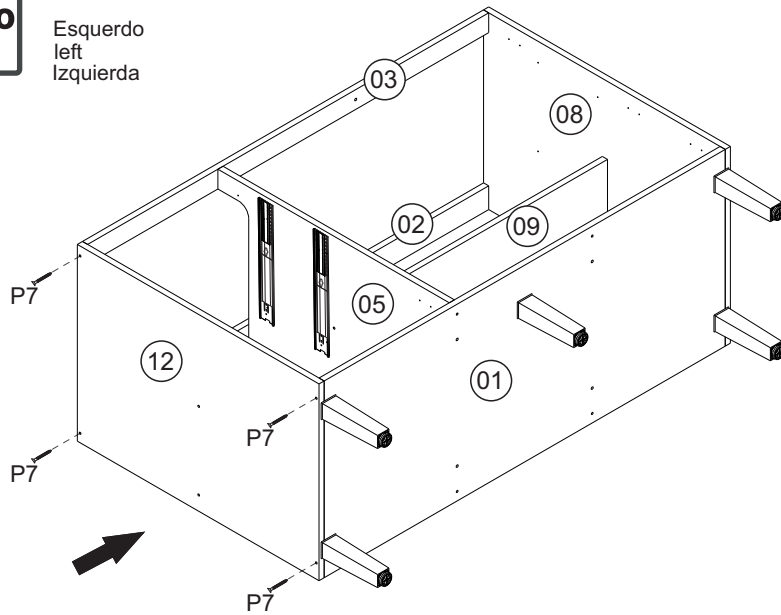

10°

Direita
 Right
 Derecha

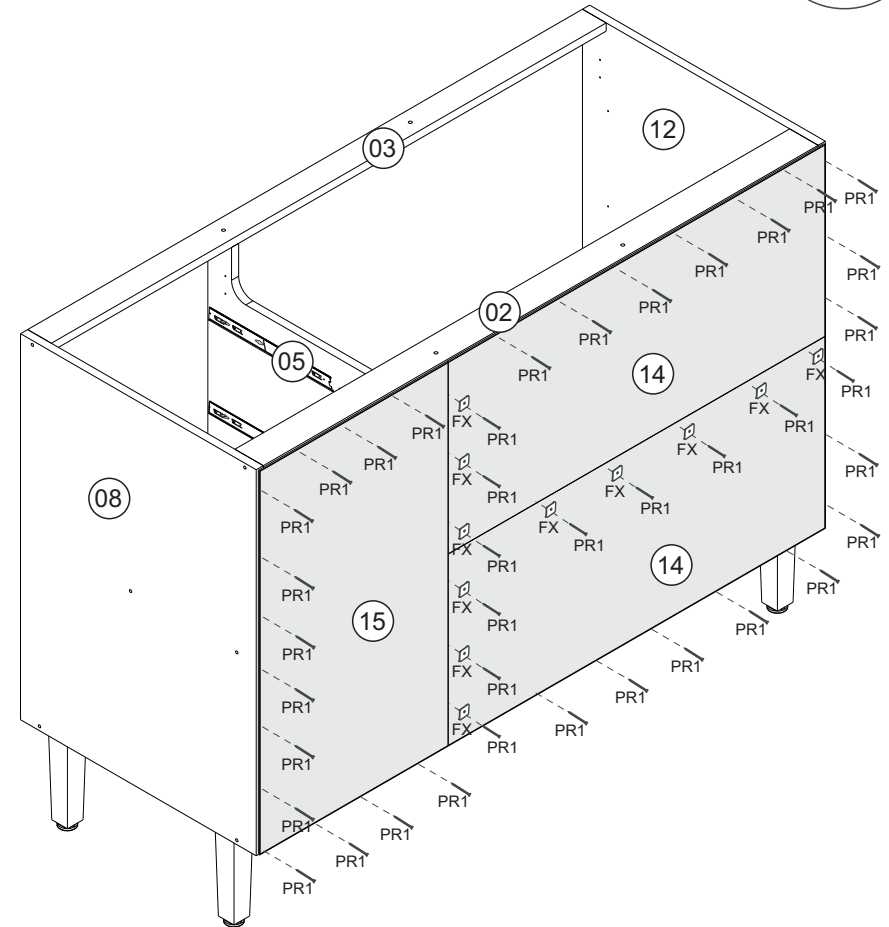
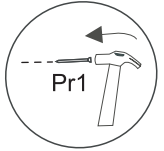

PESO SUPORTADO/PESO SOPORTADO/ WEIGHT SUPPORTED

Direita
 Right
 Derecha

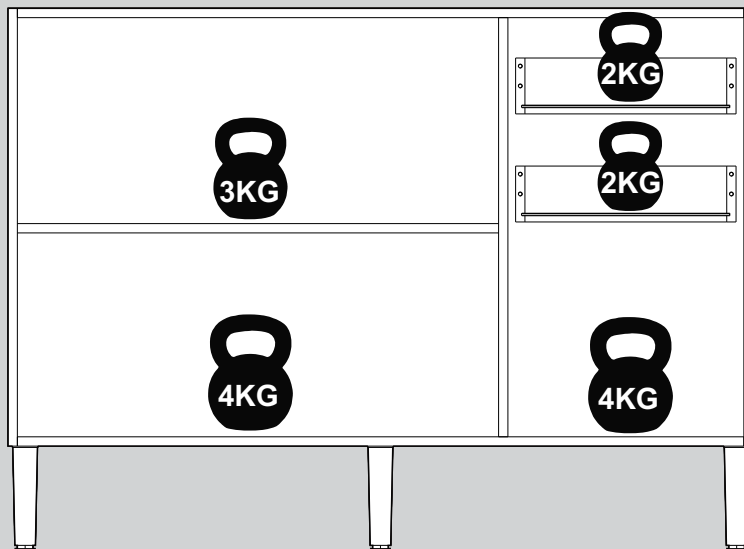

CO9320 - BALCÃO 1,20 M

Manual de Montagem
Assembly Instructions
Instrucción de Montaje

decibal[®]
móveis

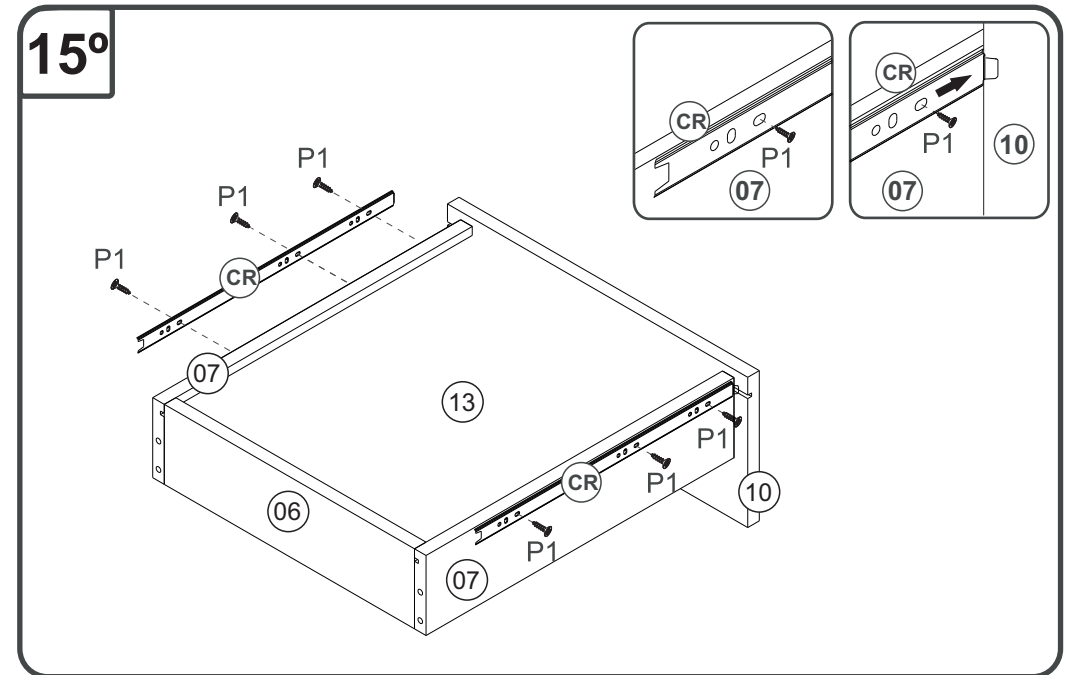
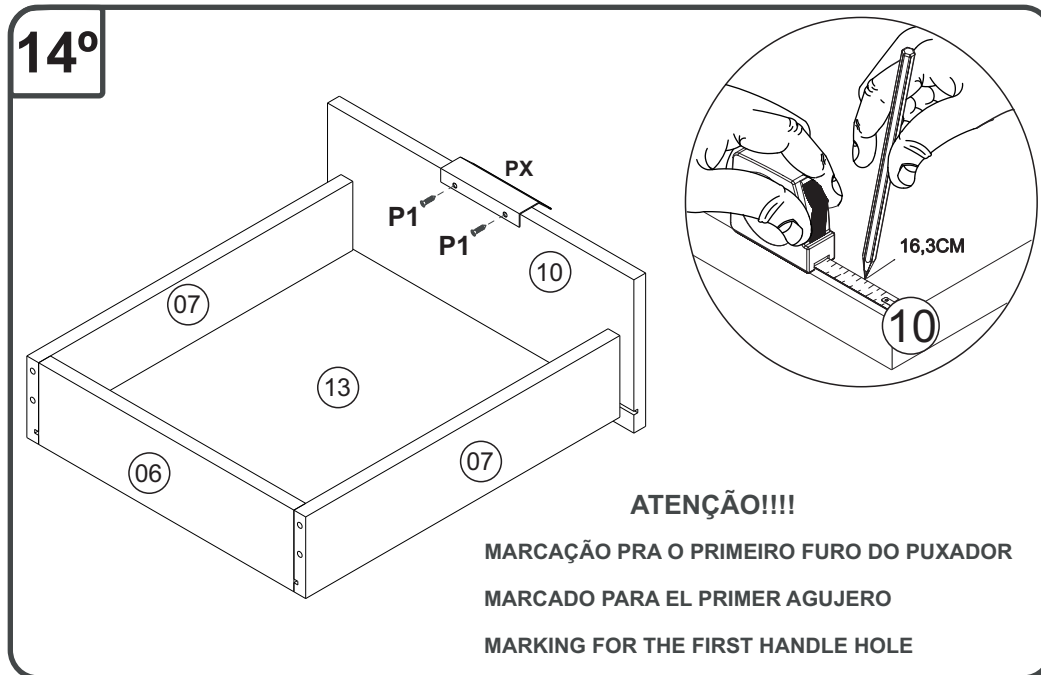
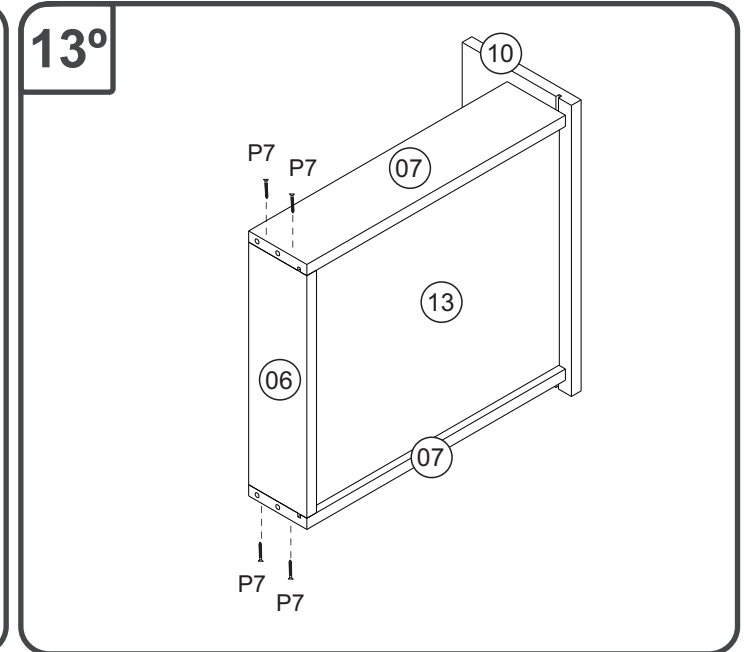
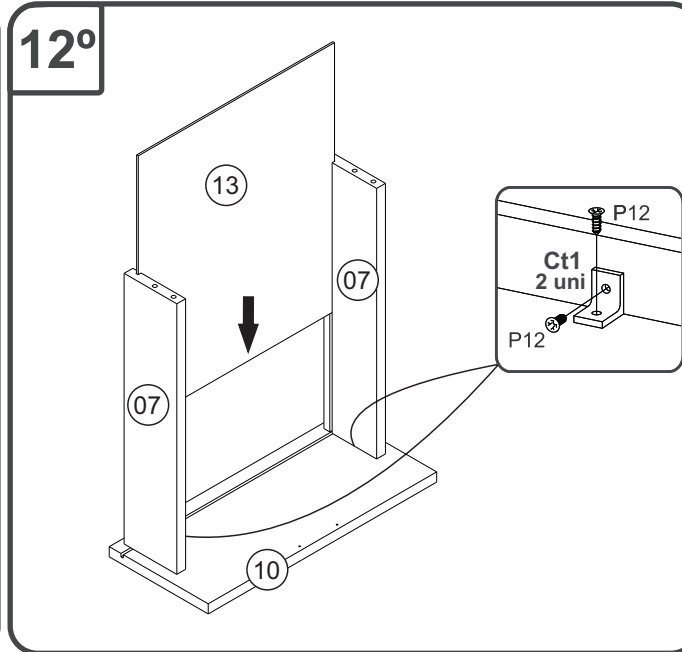
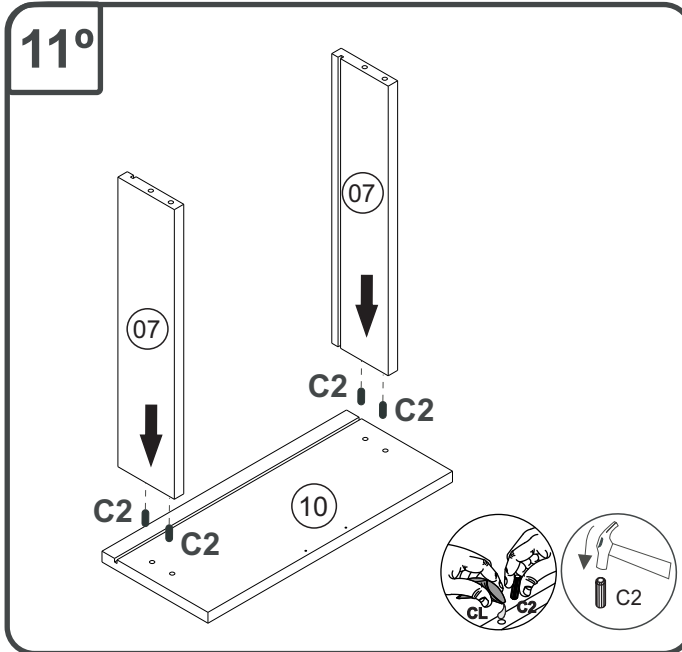

CO9320 - BALCÃO 1,20 M

Manual de Montagem
Assembly Instructions
Instrucción de Montaje

decibal[®]
móveis

16°

Direita
Right
Derecha

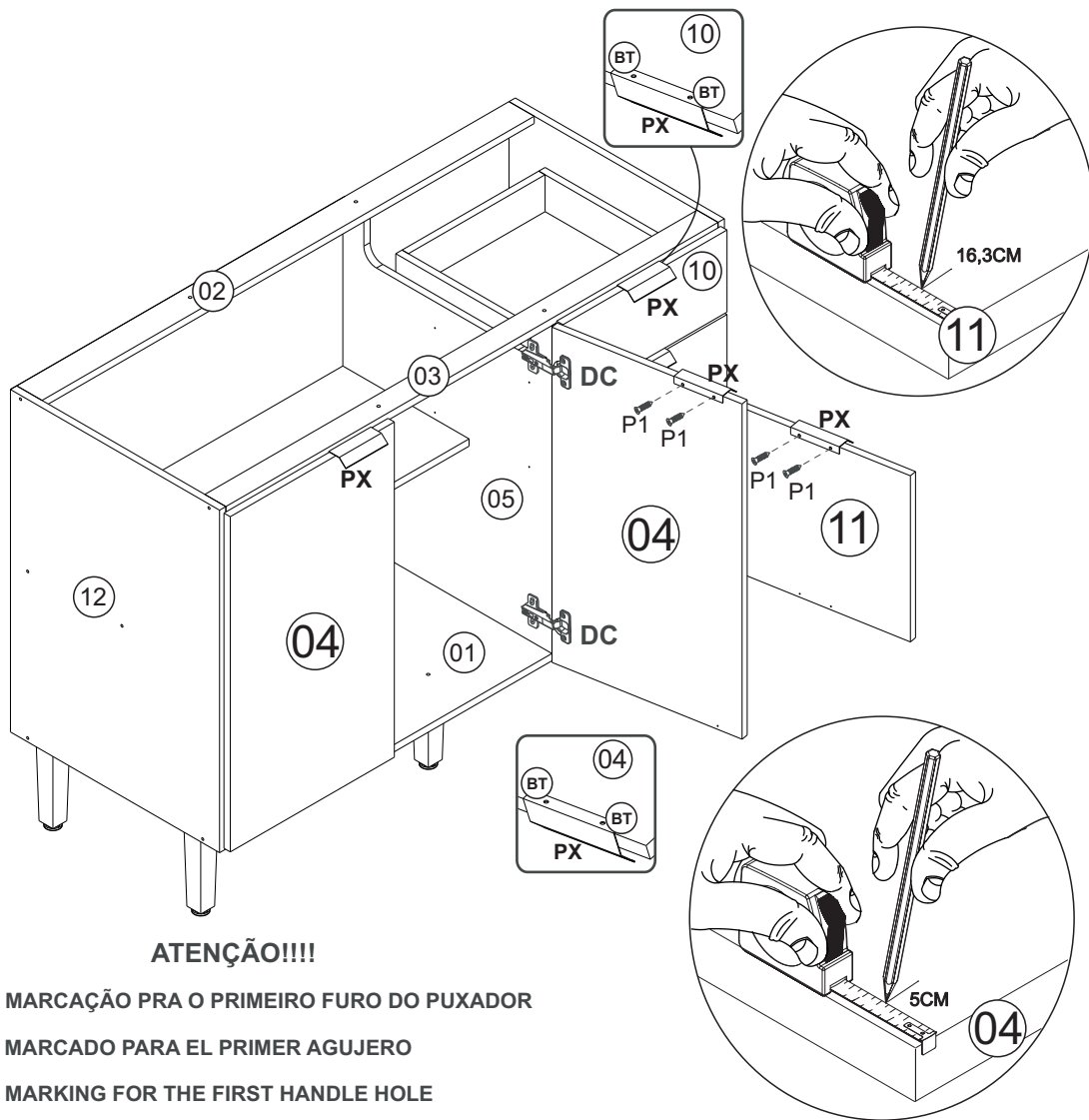
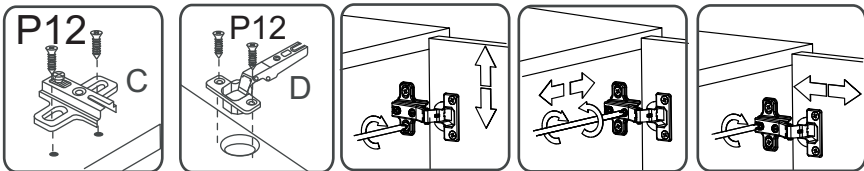

ATENÇÃO!!!!

MARCAÇÃO PRA O PRIMEIRO FURO DO PUXADOR

MARCADO PARA EL PRIMER AGUJERO

MARKING FOR THE FIRST HANDLE HOLE

Relação de Peças/ Relación de Piezas/Parts List

N°	CÓDIGO/CODE	DESCRIÇÃO/DESCRIPCIÓN/DESCRIPTION	QTD/CANT	VOL.
1	0548678	BASE INF 1170X497X15MM	1	1
2	0548680	TRAVESSA TRS/TRAVIESA/TRVERSE 1170X60X15MM	1	1
3	0548679	TRAVESSA FRT/TRAVIESA/TRVERSE 1170X50X15MM	1	1
4	0548688	PORTA/PUERTA/DOOR 690X390X15MM	2	1
5	0548686	DIVISÓRIA/DIVIDER 675X497X15MM	1	1
6	0548691	BATENTE/REVÉS CAJÓN/DRAWER BACK 325X90X15MM	1	1
7	0548690	LATERAL DE GAVETA/LATERAL CAJÓN DRAWER SIDE 400X90X15MM	4	1
8	0548677	LATERAL DIR/LATERAL/SIDE 705X497X15MM	1	1
9	0548682	PRATELERIA/ESTANTE/SHELF 775X300X15MM	1	1
10	0548689	FRENTE DE GAVETA/FRENTE CAJÓN DRAWER FRONT 390X169X15MM	2	1
11	0548685	PORTA/PUERTA/DOOR 390X342X15MM	1	1
12	0548691	BATENTE/REVÉS CAJÓN/DRAWER BACK 395X90X15MM	1	1
13	0548683	LATERAL ESQ/LATERAL/SIDE 705X497X15MM	1	1
14	0548692	FUNDO GAVETA/FONDO CAJÓN/DRAWER BOTTOM 397X355X2,8MM	2	1
15	0548681	COSTA/REVÉS/BACK 795X350X2,8MM	2	1
16	0548687	COSTA/REVÉS/BACK 700X397X2,8MM	1	1

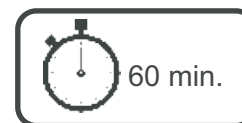

60 min.



1 montador
1 ajustador
1 Fitter

www.decibal.com.br

Ferramenta necessárias
Necessary tools
Herramientas necesarias



ATENÇÃO!!!! montadores e consumidores

* Para limpar o móveis utilize somente um pano úmido (umedecido em água pura ou água com sabão neutro). Depois, passe um pano seco. Evite a umidade excessiva.

* Evite usar álcool, água sanitária, detergente e outros produtos químicos, mesmo diluídos em água. Não utilize produtos abrasivos de nenhuma espécie

ATENCIÓN!!!! montadores e consumidores

* Para limpiar el mueble utilice solamente un paño húmedo (humedecido con agua limpia o con un jabón suave).

A continuación, utilice un paño seco. Evite el exceso de humedad.

* Evite uso de alcohol, hipoclorídoro solución basada, detergente y otros productos químicos, mismo diluídos en agua. No utilice productos abrasivos de ningún tipo.

ATTENTION!!!! assemblers and consumers

*To clean the furniture, use only a damp cloth (humidify it only in pure water ou water and neutral soap).After, use a dry cloth.Avoid excessive humidity.

*Avoid using alcohol, bleach, detergent and other chemical products, even diluted in water. Do not use any kind of abrasive cleaning agents to clean the furniture.







The use of such products may jeopardize the ?nal characteristics of the furniture.

CO9320 - BALCÃO 1,20 M







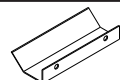

Manual de Montagem
Assembly Instructions
Instrucción de Montaje

decibal[®]
móveis

escala (1:1)

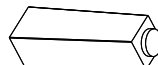
LEGENDA	DESCRIÇÃO/DESCRIPCIÓN/DESCRIPTION	CÓDIGO	QUANT.
P7	 PARAFUSO/TORNILLO/SCREW 4X45	01318	22
P1	 PARAFUSO/TORNILLO/SCREW 3,5X12	01328	34
Pr1	 PREGO/CLAVO/NAIL 10X10	01330	56
C2	 CAVILHA/TARUGO/DOWEL 6X30 MM	01211	18
PU	 PARAFUSO UNIÃO/UNIÓN DETORNILLO /SCREW UNION	01495	02
P12	 PARAFUSO/TORNILLO/SCREW 3,5X13	09927	36
P8	 PARAFUSO/TORNILLO/SCREW 5X45	01320	05

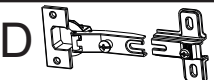
escala (N/A)

LEGENDA	DESCRIÇÃO/DESCRIPCIÓN/DESCRIPTION	CÓDIGO	QUANT.
CL	 COLA/PEGAMENTO/GLUE	01213	01
PX	 PUXADOR/PEGADOR /HANDLE (MOV410 /100MM)	11440	05
ET	 ETIQUETA LOGO DECIBAL/LABEL DECIBAL	01312	01
Ct1	 CANTONEIRA/PIEZA L/SHEET	03077	06
FX	 FIXADOR COSTA/FIJADOR FONDO/FIXER COAST	01331	12
PE	 PÉ/PATA/FOOT CINZA 170mm	11121	05
CR	 CORREDICA/CORREDERA/METALIC SLIDE LARG	02641	02
AD	 ADESIVO /ADHESIVO /ADHESIVE Griseo 11895		12
DC	 DOBRADIÇA/BISAGRA/HINGE D=35mm C=0mm	09449	06
BT	 BATENTE/BATIENTE DE SILICONA/SILICONE STOP 8MM	02921	06

ATENÇÃO!!!! montadores e consumidores

* Ajustar o torque da parafusadeira para não danificar as peças escareando o parafuso *

ATENCIÓN!!!! montadores e consumidores

* Ajuste el torque del destornillador para no dañar las piezas avallanando el tornillo *

ATTENTION!!!! assemblers and consumers

* Adjust the torque of the screwdriver so as not to damage the parts by countersinking the screw *

Medida em mm



CO9400 - MÓDULO FORNO

Manual de Montagem
Assembly Instructions
Instrucción de Montaje

decibal[®]
móveis

04°

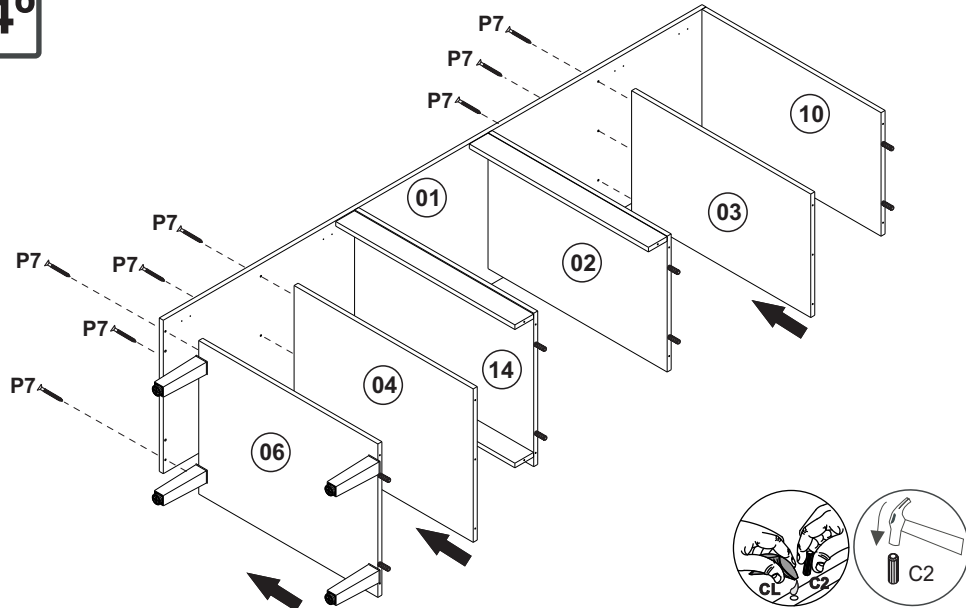

06°

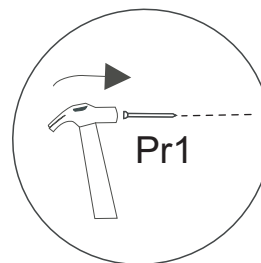

05°

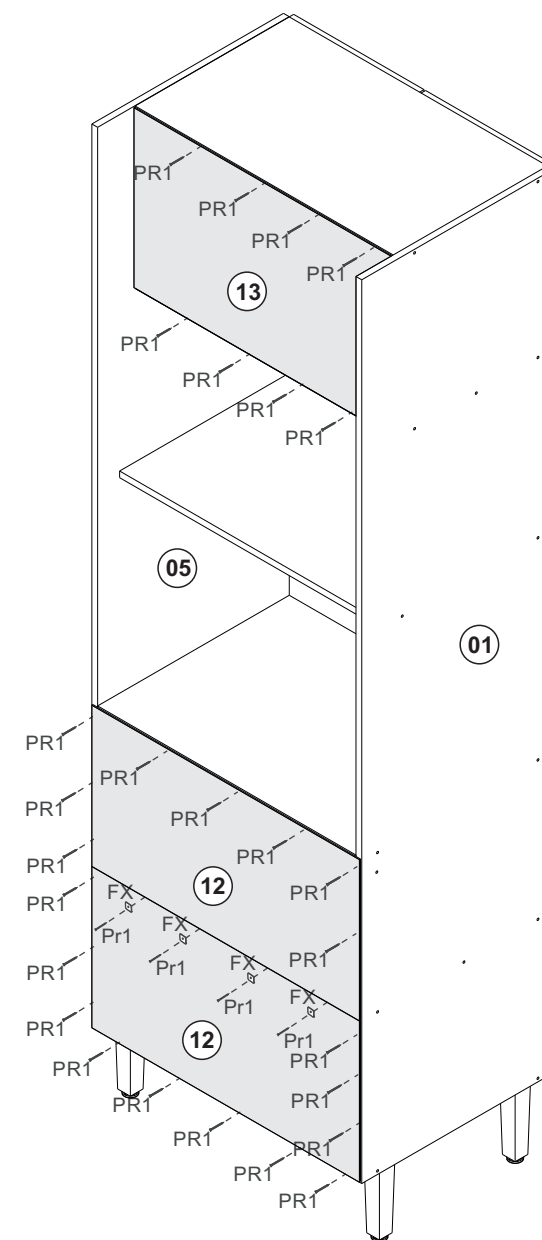
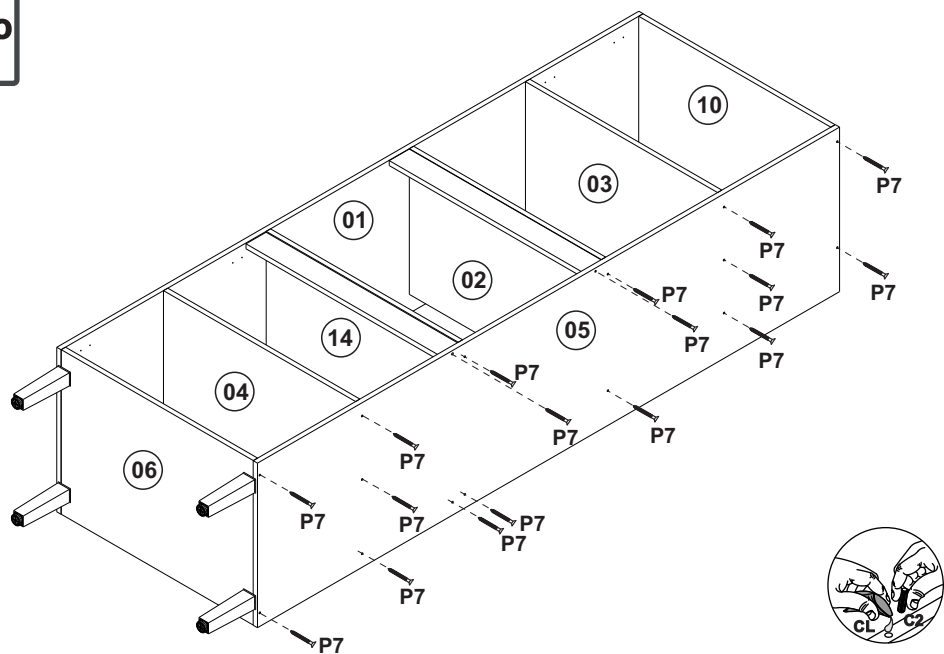

CO9400 - MÓDULO FORNO

Manual de Montagem
Assembly Instructions
Instrucción de Montaje

decibal[®]
móveis

07°

Fixação parede
Fixed in the wall

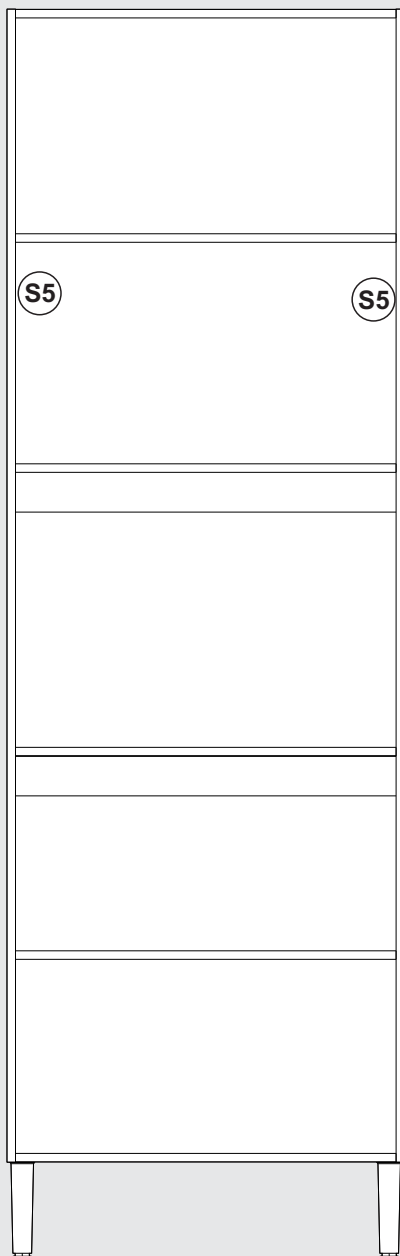
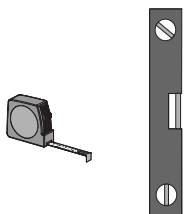
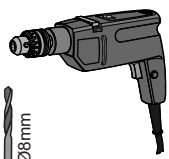
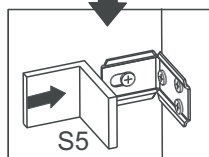
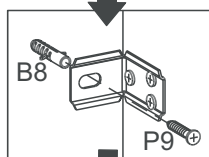
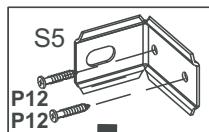

PESO SUPORTADO/PESO SOPORTADO/WEIGHT SUPPORTED

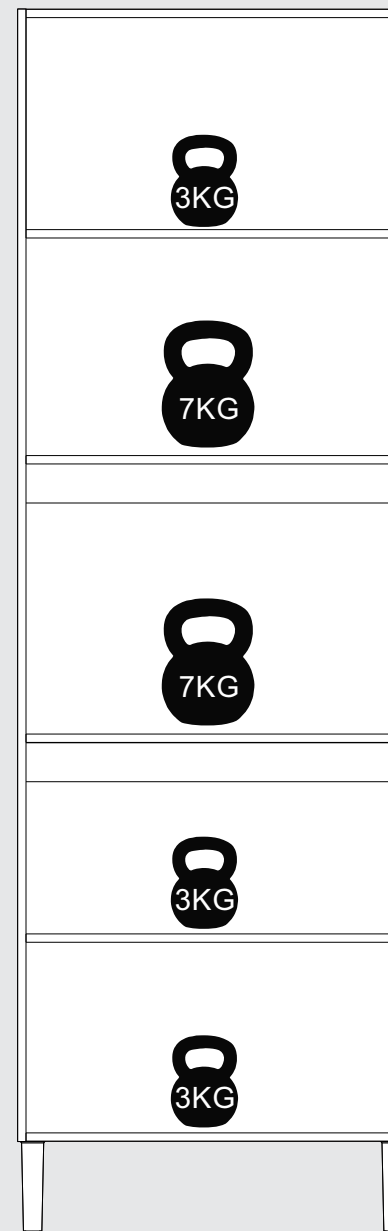

CO9400 - MÓDULO FORNO

Manual de Montagem
Assembly Instructions
Instrucción de Montaje

decibal[®]
móveis

8°

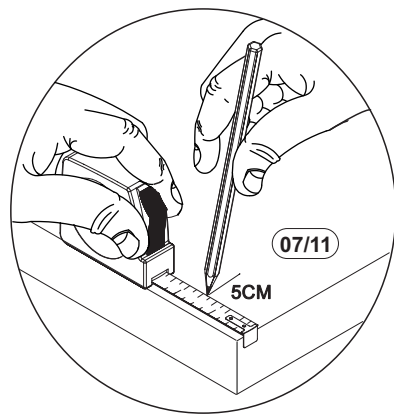
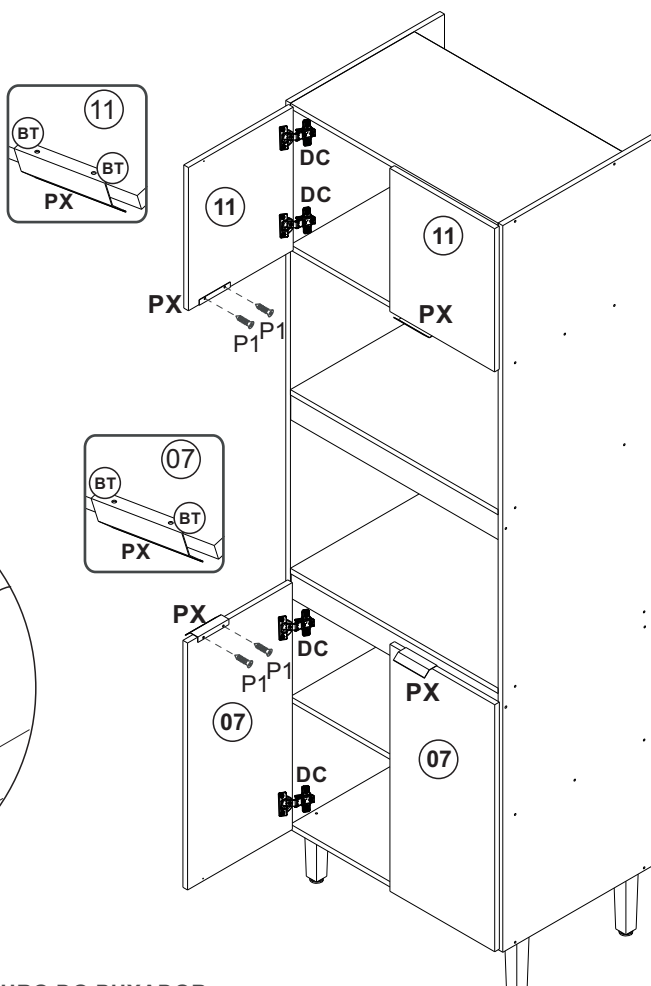
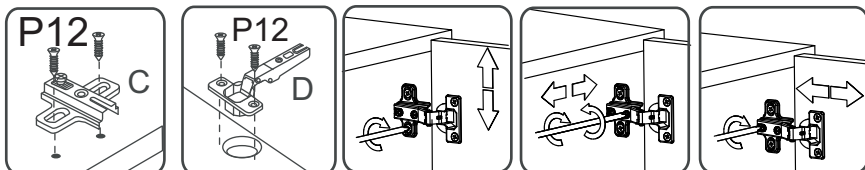

ATENÇÃO!!!!

MARCAÇÃO PRA O PRIMEIRO FURO DO PUXADOR

MARCADO PARA EL PRIMER AGUJERO

MARKING FOR THE FIRST HANDLE HOLE

escala (N/A)









LEGENDA	DESCRIÇÃO/DESCRIPCIÓN/DESCRIPTION	CÓDIGO	QUANT.
CL	COLA/PEGAMENTO/GLUE	01213	01
ET	ETIQUETA LOGO DECIBAL/LABEL DECIBAL	01312	01
AD	ADESIVO/ADHESIVO/ADHESIVE	(GRISEO)11895	34
Ct1	CANTONEIRA/PIEZA L/SHEET	03077	08
BT	BATENTE/BATIENTE DE SILICONA/SILICONE STOP 8MM	02921	08
DC	DOBRADIÇA/BISAGRA/HINGE D=35mm C=0	09449	08
FX	FIXADOR COSTA/FIJADOR FONDO/FIXER COAST	01331	06
S5	CAPA SUPORTE AÉREO /PORTADA APOYO AÉREO/AIR SUPPORT COVER (EBANO) 04501	03828	02
PE	PÉ/PATA/FOOT (170MM)	11121	04
PX	PUXADOR/PEGADOR /HANDLE (MOV410 /100MM)	11440	04
B	BUCHA / BUJE / BUCHING 8 MM	01311	02

CO9400 - MÓDULO FORNO

Manual de Montagem
Assembly Instructions
Instrucción de Montaje



Ferragens/ Herrajes/ Hardware escala (1:1)

LEGENDA	DESCRIÇÃO/DESCRIPCIÓN/DESCRIPTION	CÓDIGO	QUANT.
P7	 PARAFUSO/TORNILLO/SCREW 4X45	01318	34
PR1	 PREGO/CLAVO/NAIL 10X10	01330	60
C2	 CAVILHA/TARUGO/DOWEL 6X30 MM	01211	18
P12	 PARAFUSO/TORNILLO/SCREW 3,5X13 CABEÇA FLANGEADA	09927	52
P9	 PARAFUSO/TORNILLO/SCREW 6X50	03827	02
P1	 PARAFUSO/TORNILLO/SCREW 3,5X12	01328	08
P8	 PARAFUSO/TORNILLO/SCREW 5X45	01320	04
PU	 PARAFUSO UNIÃO/UNIÓN DETORNILLO /SCREW UNION	01495	02

Relação de Peças/ Relación de Piezas/Parts List

Nº	CÓDIGO/CODE	DESCRIÇÃO/DESCRIPCIÓN/DESCRIPTION	QTD/CANT	VOL.
1	0548717	LATERAL ESQ/LATERAL/SIDE 2030X497X15MM	1,00	1
2	0548894	BASE FORNO 670X440X15MM	1,00	1
3	0548721	BASE SUP FORNO 670X400X15MM	1,00	1
4	0548896	PRATELEIRA INF/ESTANTE/SHELF 670X497X15MM	1,00	1
5	0548891	LATERAL DIR/LATERAL/SIDE 2030X497X15M	1,00	1
6	0548716	BASE INF 670X497X15M	1,00	2
7	0548725	PORTA INF/PUERTA/DOOR 690X338X15M	2,00	2
8	0548719	TRAVESSA/TRAVIESA/TRVERSE 670X70X15M	2,00	2
9	0548892	TRAVESSA TRS/TRAVIESA/TRVERSE 670X70X15M	1,00	2
10	0548718	BASE SUP 670X400X15M	1,00	2
11	0548723	PORTA/PUERTA/DOOR 400X338X15M	2,00	2
12	0548724	COSTA/REVÉS/BACK 694X362X2,8M	2,00	2
13	0548895	COSTA SUP/REVÉS/BACK 670X404X2,8M	1,00	2
14	0548893	TAMPO/TAPA/TOP 670X497X2,8M	1,00	2

ATENÇÃO!!!! montadores e consumidores
* Ajustar o torque da parafusadeira para não danificar as peças escareando o parafuso *

ATENCIÓN!!!! montadores e consumidores
* Ajuste el torque del destornillador para no dañar las piezas avallanando el tornillo *

ATTENTION!!!! assemblers and consumers
* Adjust the torque of the screwdriver so as not to damage the parts by countersinking the screw *

Ferramenta necessária
Necessary tools
Herramientas necesarias



ATENÇÃO!!!! montadores e consumidores
* Para limpar o móveis utilize somente um pano úmido (umedecido em água pura ou água com sabão neutro). Depois, passe um pano seco. Evite a umidade excessiva.
* Evite usar álcool, água sanitária, detergente e outros produtos químicos, mesmo diluídos em água. Não utilize produtos abrasivos de nenhuma espécie

ATENCIÓN!!!! montadores e consumidores
* Para limpiar el mueble utilice solamente un paño húmedo (humedecido con agua limpia o con un jabón suave). A continuación, utilice un paño seco. Evite el exceso de humedad.
* Evite uso de alcohol, hipoclorido solución basada, detergente y otros productos químicos, mismo diluídos en agua. No utilice productos abrasivos de ningún tipo.
ATTENTION!!!! assemblers and consumers
* To clean the furniture, use only a damp cloth (humidify it only in pure water ou water and neutral soap). After, use a dry cloth. Avoid excessive humidity.
* Avoid using alcohol, bleach, detergent and other chemical products, even diluted in water. Do not use any kind of abrasive cleaning agents to clean the furniture.
The use of such products may jeopardize the ?nal characteristics of the furniture.

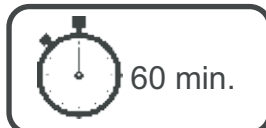

www.decibal.com.br



Medida em mm

TH1200 - TAMPO 1,20 M

Manual de Montagem
Assembly Instructions
Instrucción de Montaje

decibal[®]
móveis 5veis

Produto Montado
Producto final
Assembled

