

ASSEMBLY INSTRUCTIONS MANUAL DE MONTAGEM / INSTRUCCIONES DE ARMADO

LOS ANGELES CORNER OFFICE TABLE WITH KEY
MESA DE CANTO LOS ANGELES COM CHAVE
ESCRITORIO RINCONERO LOS ANGELES CON CLAVE

Reference
Referência
Referencia

210025

Revise
Revisão
Revisión

00

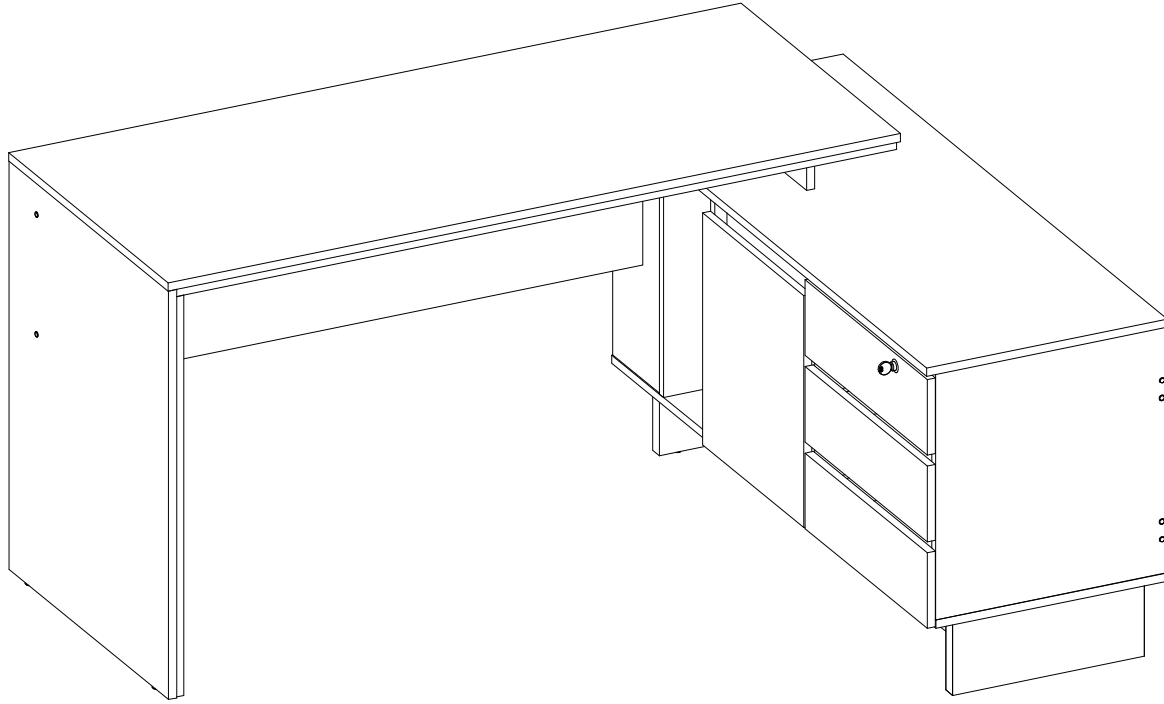

YOU WILL NEED / VOCÊ VAI PRECISAR DE / USTED NECESITARÁ

Tools not supplied / Ferramentas não fornecidas / Herramientas no incluidas

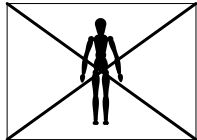

1 Person
1 Pessoa
1 Persona

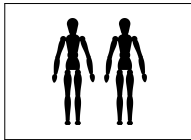

2 People
2 Pessoas
2 Personas

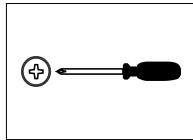

Screwdriver Phillips
Chave Phillips
Destornillador cruz

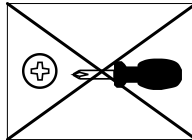

Small screwdriver Philips
Chave Phillips menor
Destornillador cruz menor

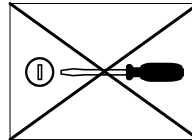

Screwdriver slotted
Chave fenda
Destornillador plano

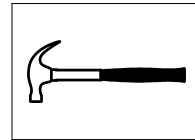

Hammer
Martelo
Martillo

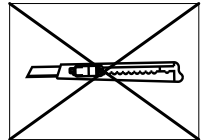

Stylet
Estilete
Estilete

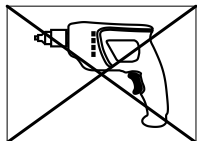

Drill machine
Furadeira
Taladro

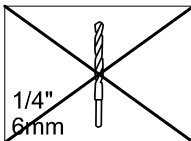

Drill bit
Broca
Taladro

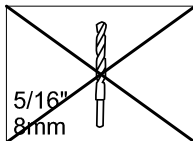

Drill bit
Broca
Taladro

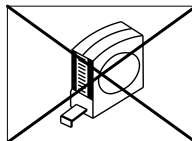

Measuring tape
Trena
Cinta de medición

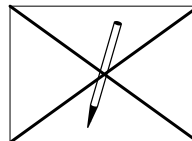

Pencil
Lápis
Lápis

NOTES: The separation of the accessories before you start the assembly will facilitate the same. In case of doubt on the size of the screws and bolts, use the ruler to bottom of page 3.

NOTAS: A separação dos acessórios antes de iniciar a montagem facilitará a mesma. Em caso de dúvida no tamanho dos parafusos e cavilhas, utilize a régua ao final da página 3.

NOTAS: La separación de los accesorios antes de comenzar el armado facilitará el mismo. En caso de duda sobre el tamaño de los tornillos y taquetes, utilice la regla al pie de página 3.

MAXIMUM RECOMMENDED WEIGHT
BEING THIS EVENLY DISTRIBUTED

PESO MÁXIMO RECOMENDADO SENDO
ESTE DISTRIBUÍDO UNIFORMEMENTE

PESO MÁXIMO RECOMENDADO SIENDO
ESTE UNIFORMEMENTE DISTRIBUIDO

	LB	KG
C	6	3
D	11	5
F	22	10
H	44	20

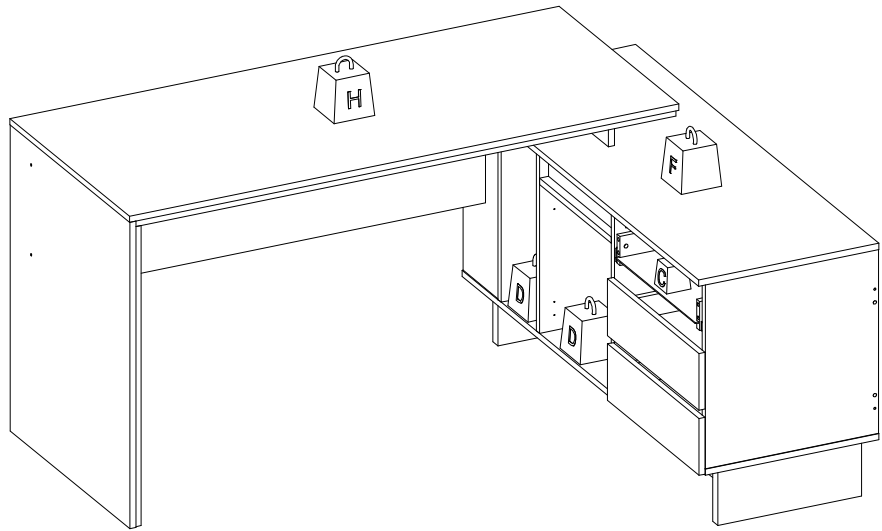





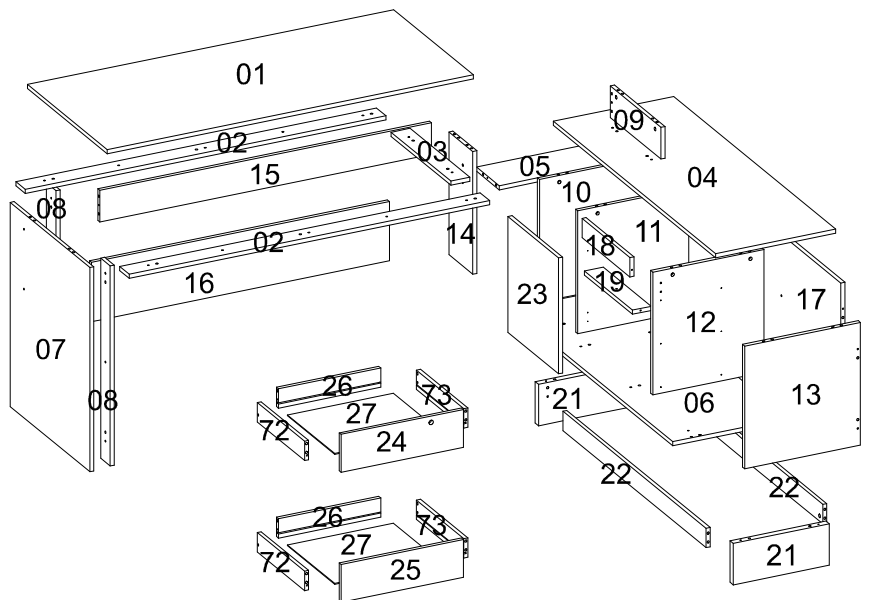







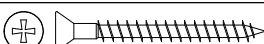



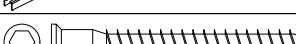



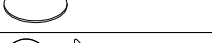
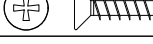
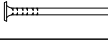

Nº	Measures_Inches	Medidas_cm	Qty./Qtd.
01	53 3/8 x 23 1/4 x 5/8	135.5 x 59.0 x 1.5	1
02	52 1/2 x 2 3/4 x 5/8	133.4 x 7.0 x 1.5	2
03	2 3/4 x 17 3/8 x 5/8	7.0 x 44.2 x 1.5	1
04	47 1/4 x 17 1/2 x 5/8	120.0 x 44.5 x 1.5	1
05	15 1/2 x 6 3/4 x 5/8	39.4 x 17.0 x 1.5	1
06	47 1/4 x 16 7/8 x 5/8	120.0 x 42.8 x 1.5	1
07	29 1/8 x 23 1/4 x 5/8	74.0 x 59.0 x 1.5	1
08	28 1/2 x 2 3/4 x 5/8	72.5 x 7.0 x 1.5	2
09	4 1/2 x 14 3/4 x 5/8	11.5 x 37.5 x 1.5	1
10	17 1/2 x 16 1/8 x 5/8	44.5 x 41.1 x 1.5	1
11	17 1/2 x 16 1/8 x 5/8	44.5 x 41.1 x 1.5	1
12	17 1/2 x 16 1/8 x 5/8	44.5 x 41.1 x 1.5	1
13	17 1/2 x 16 7/8 x 5/8	44.5 x 42.8 x 1.5	1
14	17 1/2 x 7 x 5/8	44.5 x 17.7 x 1.5	1
15	48 1/4 x 4 1/2 x 5/8	122.7 x 11.5 x 1.5	1
16	43 3/8 x 8 1/2 x 5/8	110.2 x 21.5 x 1.5	1
17	46 5/8 x 17 1/2 x 5/8	118.3 x 44.5 x 1.5	1
18	14 x 2 3/4 x 5/8	35.5 x 7.0 x 1.5	1
19	14 x 2 3/4 x 5/8	35.5 x 7.0 x 1.5	1
21	14 x 5 7/8 x 1	35.5 x 15.0 x 2.5	2
22	41 3/4 x 2 3/4 x 5/8	106.0 x 7.0 x 1.5	2
23	14 3/4 x 16 1/2 x 5/8	37.5 x 42.0 x 1.5	1
24	17 3/4 x 5 3/8 x 5/8	45.2 x 13.7 x 1.5	1
25	17 3/4 x 5 3/8 x 5/8	45.2 x 13.7 x 1.5	2
26	14 7/8 x 2 3/4 x 5/8	37.8 x 7.0 x 1.5	3
27	15 3/8 x 13 3/4 x 1/8	39.2 x 34.9 x 0.3	3
72	13 3/4 x 2 3/4 x 5/8	35.0 x 7.0 x 1.5	3
73	13 3/4 x 2 3/4 x 5/8	35.0 x 7.0 x 1.5	3

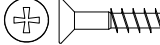
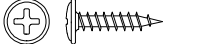
PARTS IDENTIFICATION
IDENTIFICAÇÃO DAS PEÇAS / IDENTIFICACIÓN DE LAS PIEZAS

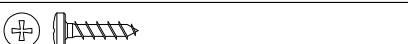

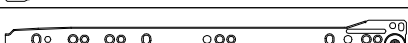
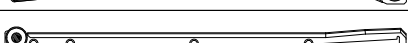
IDENTIFICATION OF ACCESSORIES IDENTIFICAÇÃO DOS ACESSÓRIOS/ IDENTIFICACIÓN DE ACCESORIOS

A1		Glue / Cola / Pegamento	13 g	1
A2		Small plastic foot / Sapata redonda / Pie plástico	14 mm	6
A3		Trapeze / Trapézio / Trapecio	-	6
A4		Metalic bracket / Cantoneira de metal / Suporte de metal	22x22 mm	2
D		Flat head screw / Parafuso chato / Tornillo de cabeza plana	4,0x40 mm	4
D5		Hinge shim / Calço dobradiça / Bisagra de calce	-	2
E		Wooden dowel / Cavilha / Taquete	8x30 mm	66
F9		Metal hinge straight / Dobradiça reta / Bisagra recta	26 mm	2
G		Structural screw / Parafuso estrutural / Tornillo estructural	5,0x50 mm	16
G2		Door stop / Batente de porta / Tope de puerta	-	1
H		Allen key / Chave allen / Liave allen	3 mm	1
I		Structural screw cover/Tampa parafuso estrutural/Tapa tornillo estructural	-	12
J		Simple minifix screw / Haste minifix simples / Tornillo minifix simple	-	18
L		Drum lock / Tambor minifix / Tambor minifix	12 mm	18
M		Bore patch adhesive / Tapa furo adesivo / Tapones adhesivo	-	17
M1		Flat head screw / Parafuso chato / Tornillo de cabeza plana	3,5x25 mm	18
N		Nail / Prego / Clavo	10x10	6
N7		Wooden dowel / Cavilha / Taquete	8x20 mm	12
N14		Lock / Fechadura/ Cerradura	15 mm	1
O		Flat head screw / Parafuso chato / Tornillo de cabeza plana	4,5x45 mm	17
o9		Flanged head screw / Parafuso flangeado / Tornillo de cabeza flangeada	3,5x16 mm	4
P		Pan head screw / Parafuso panela / Tornillo de pan	4,5x25 mm	6
P5		Flat head screw / Parafuso chato especial / Tornillo de cabeza plana	3,5x14 mm	24
S		Pan head screw / Parafuso panela / Tornillo de pan	3,5x14 mm	14
VA		Metallic slide the left field / Corrediça lateral esquerda / Corredera lateral izquierda	350 mm	3
VB		Metallic slide the right field / Corrediça lateral direita / Corredera lateral derecha	350 mm	3
VC		Drawer slide left / Corrediça gaveta esquerda / Corredera izquierda cajón	350 mm	3
VD		Drawer slide right / Corrediça gaveta direita / Corredera derecha cajón	350 mm	3
Z		Plastic hole plugs / Tapa furo plástico / Tapones plásticos	8 mm	2

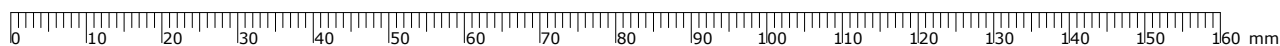

PRE-ASSEMBLE
PRÉ-MONTAGE / PRE ARMADO

01

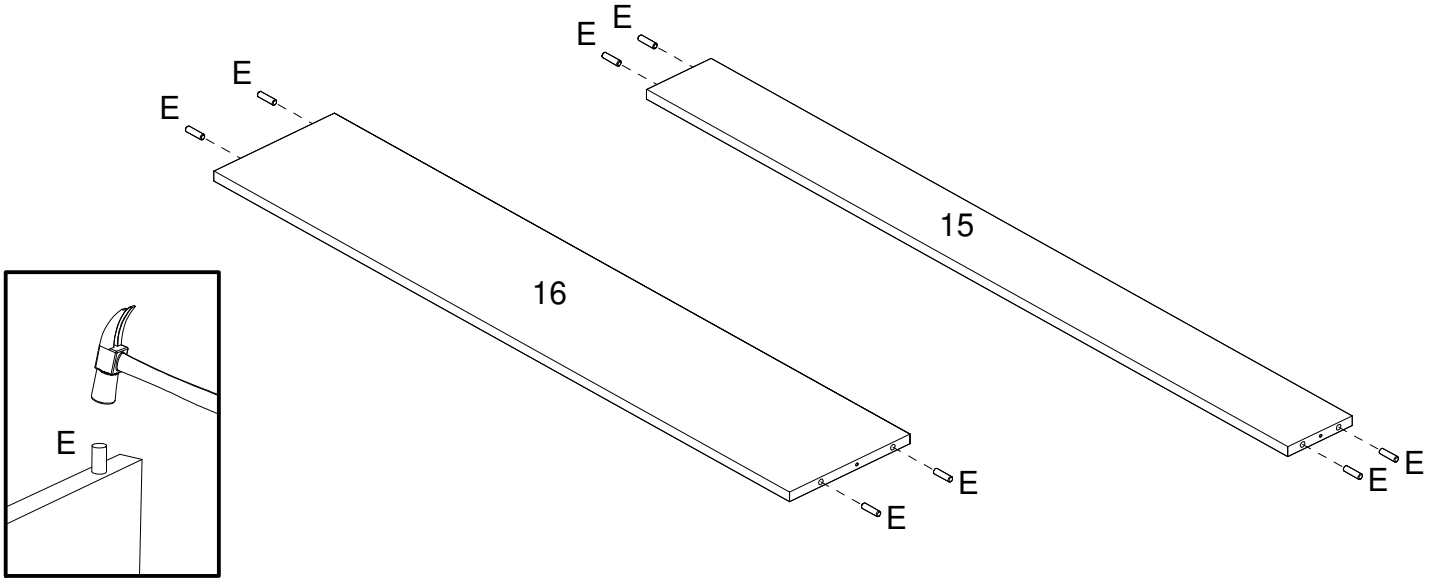

02

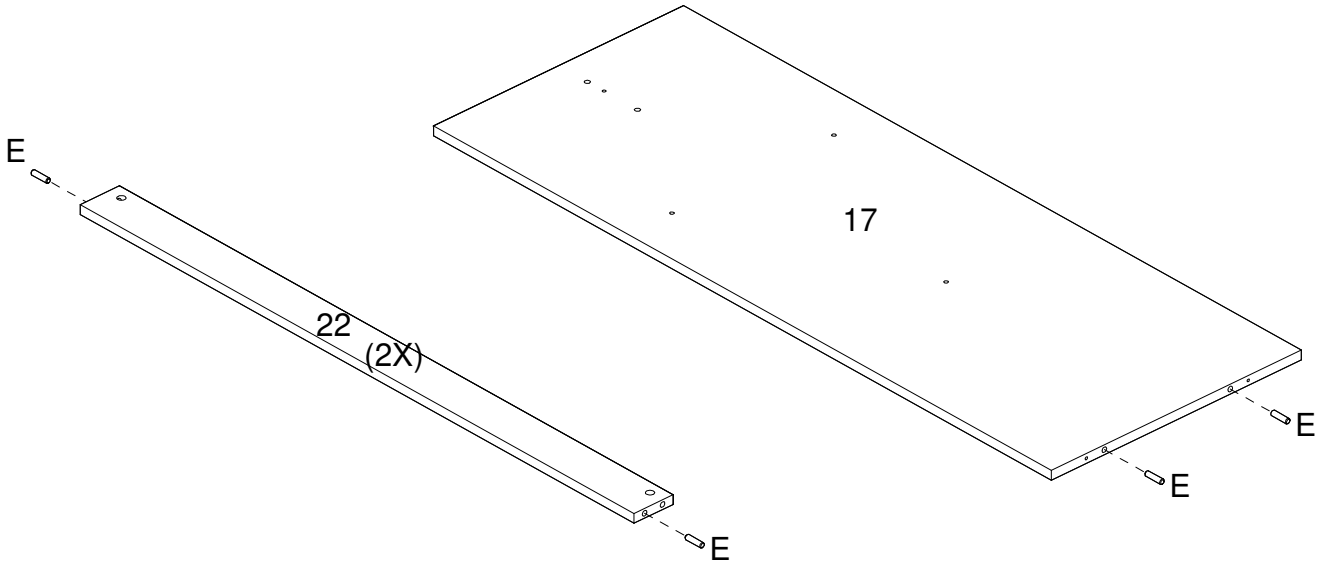

03

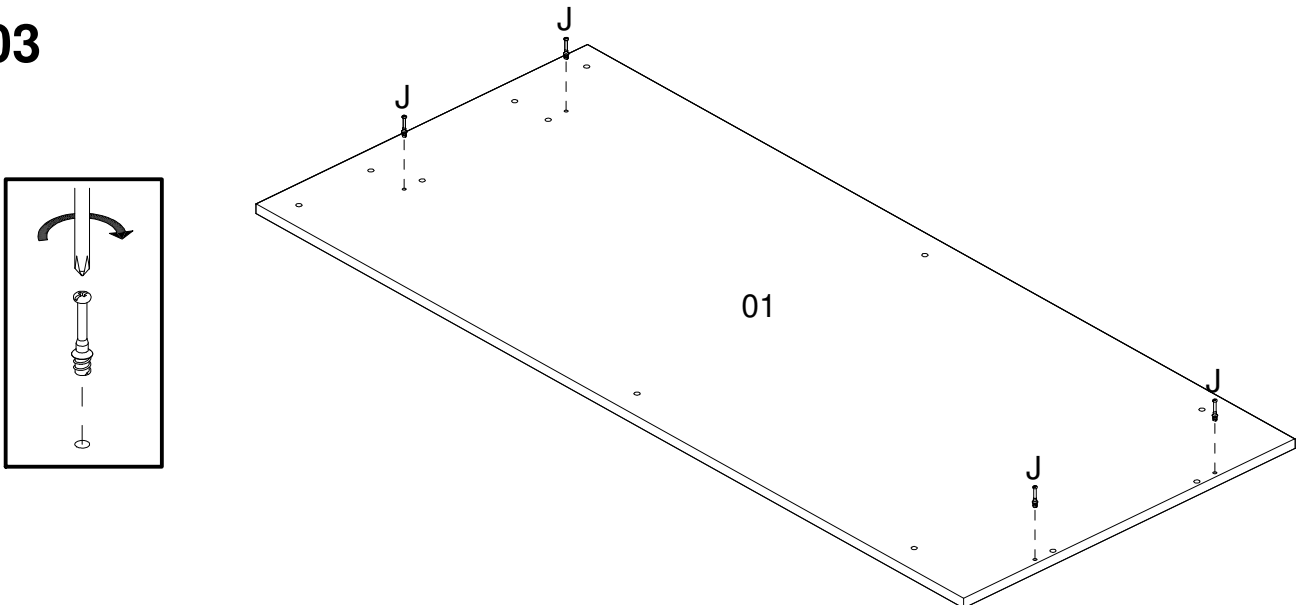

04

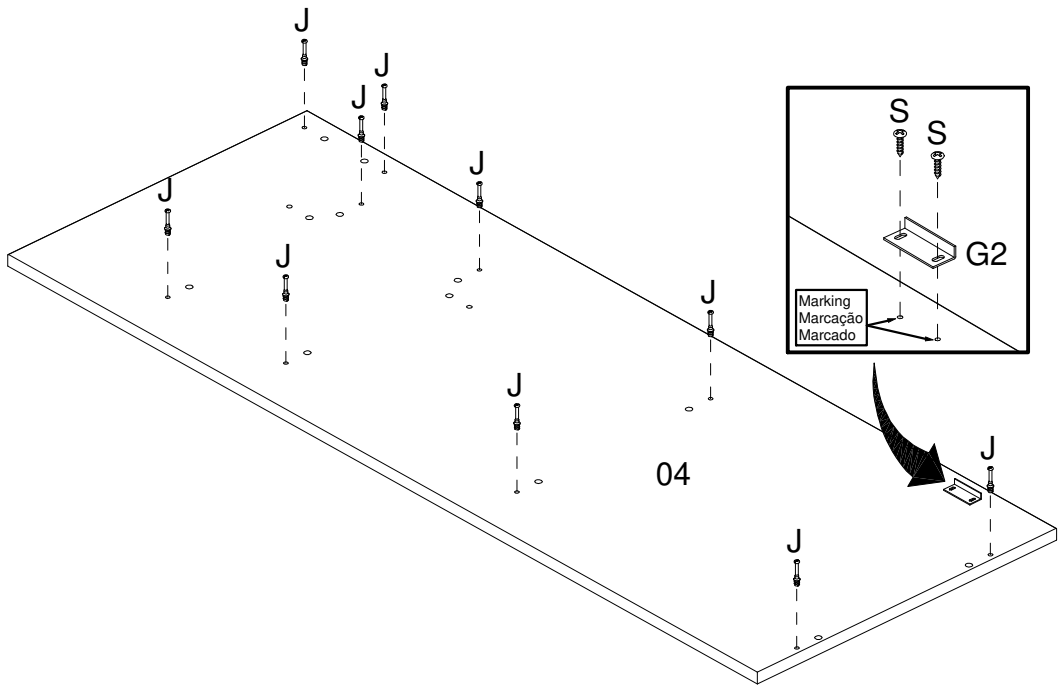

05

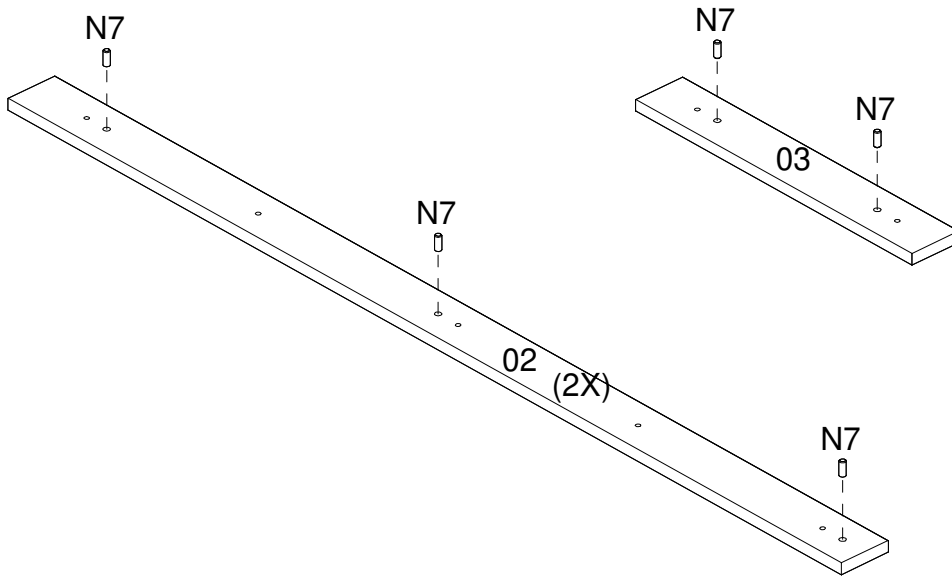

06

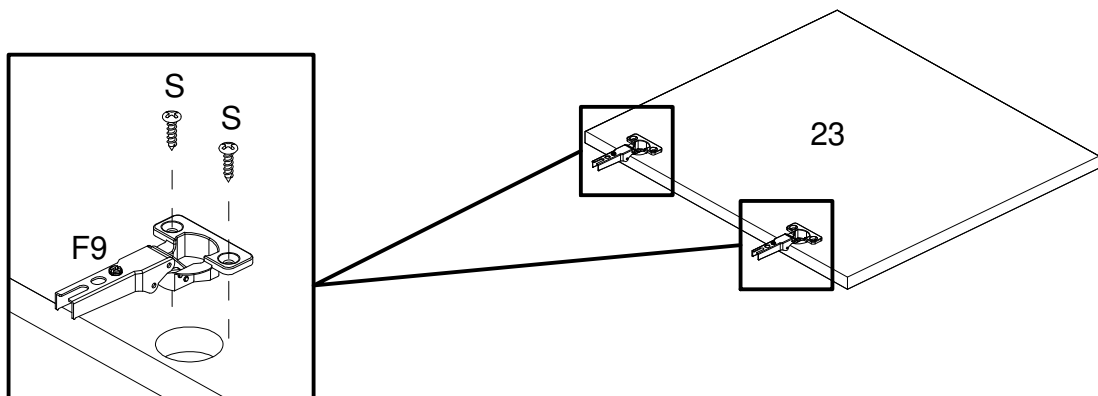

07

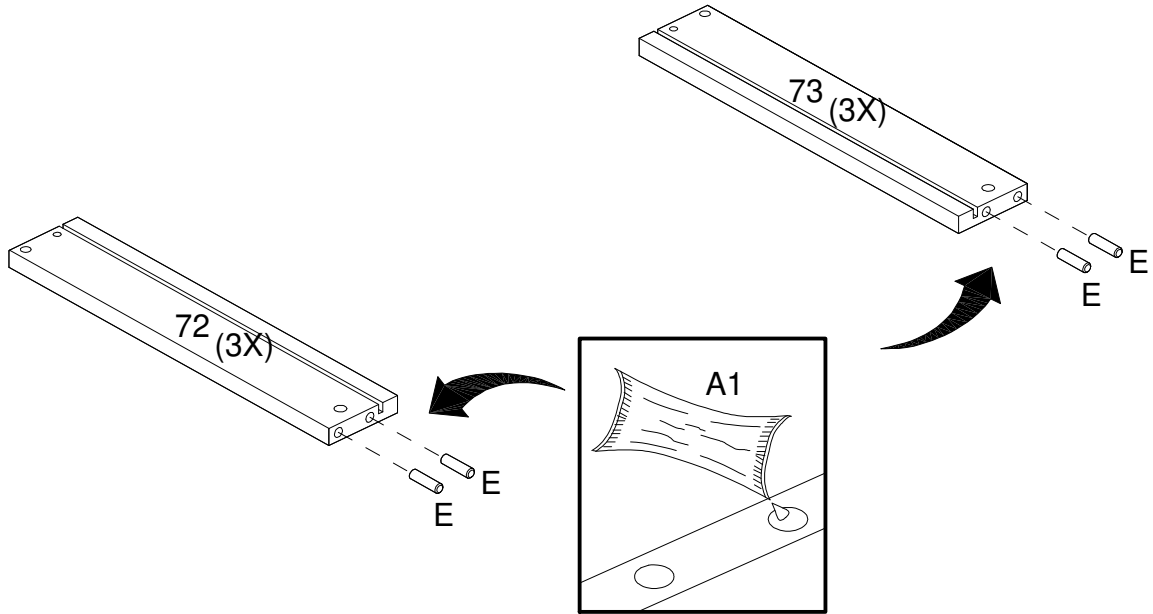

08

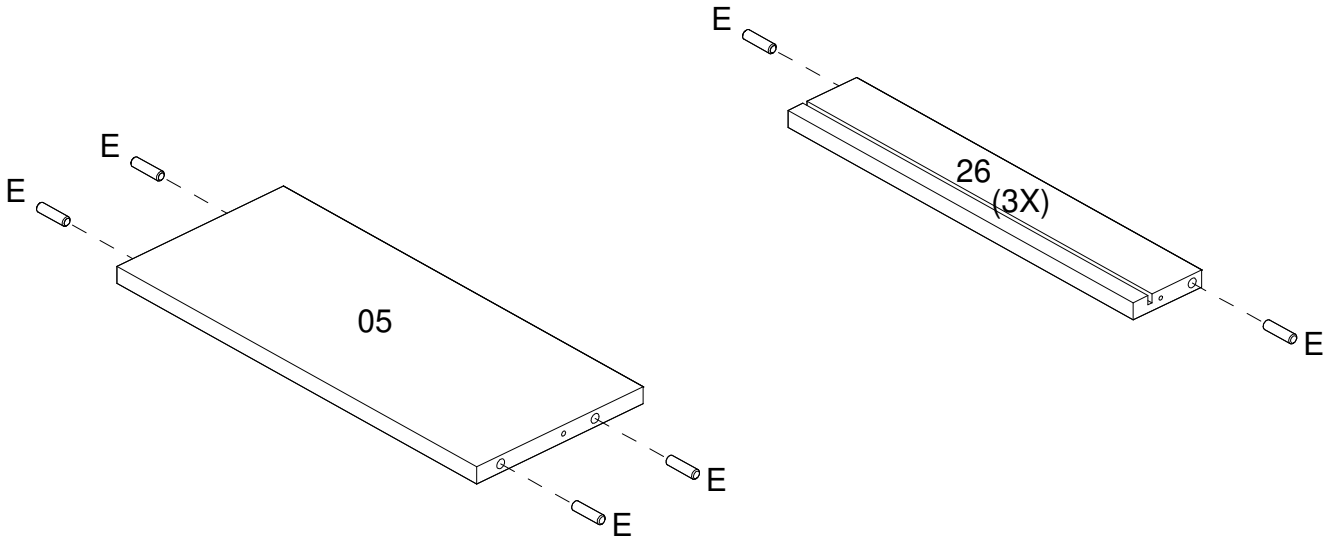

09

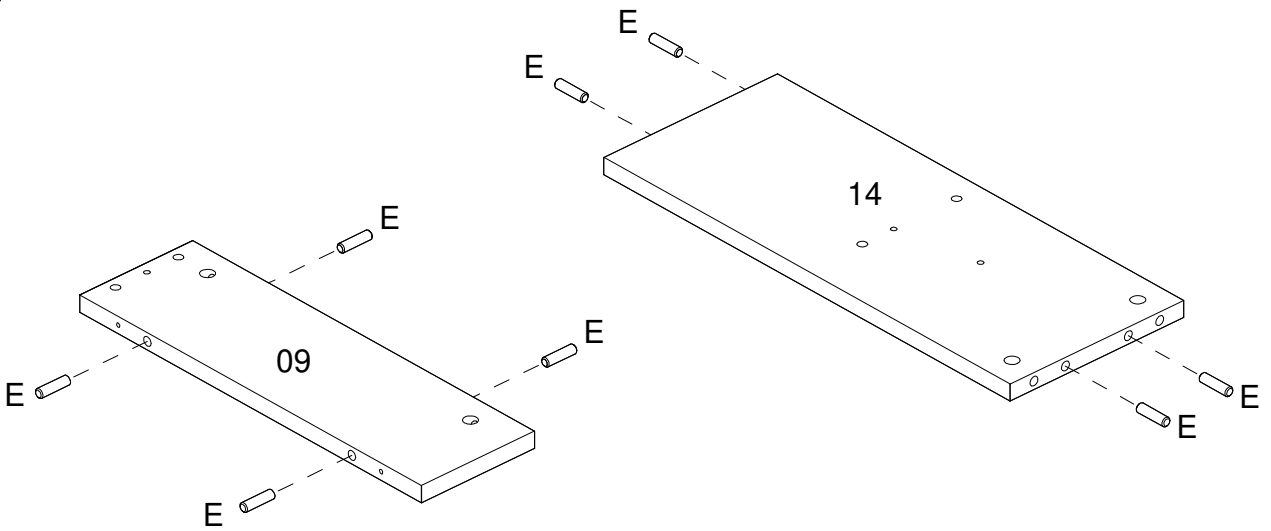

10

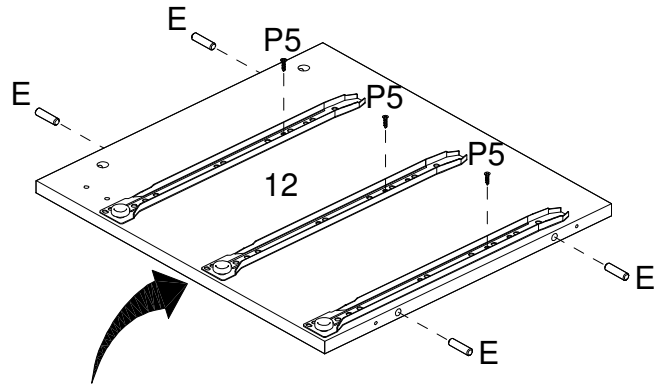

ATTENTION FOR POSITION
ATENÇÃO PARA POSIÇÃO
ATENCIÓN CON LA POSICIÓN

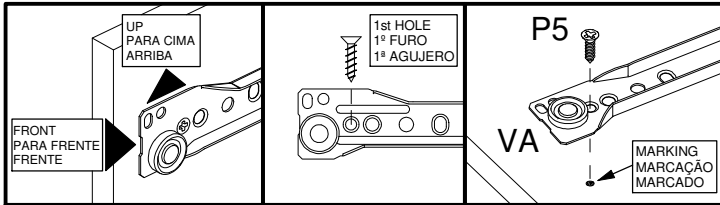

11

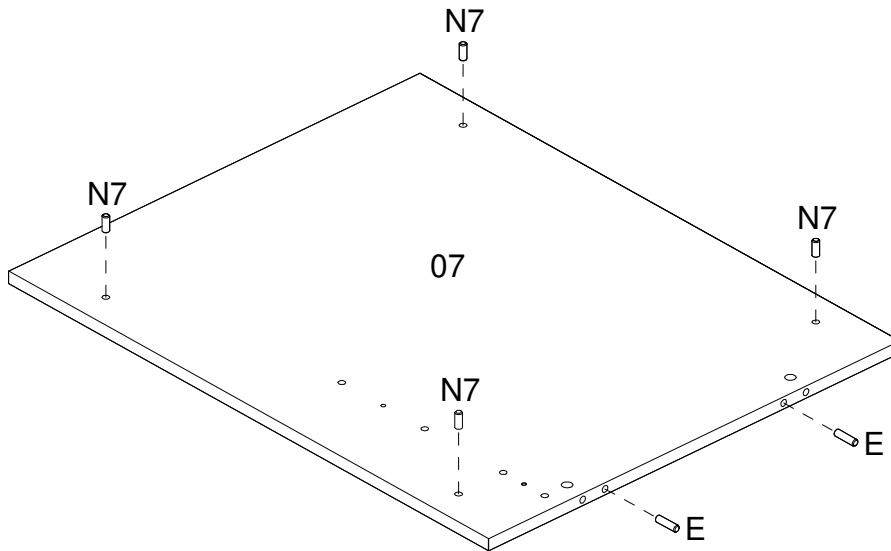

12

ATTENTION FOR POSITION
ATENÇÃO PARA POSIÇÃO
ATENCIÓN CON LA POSICIÓN

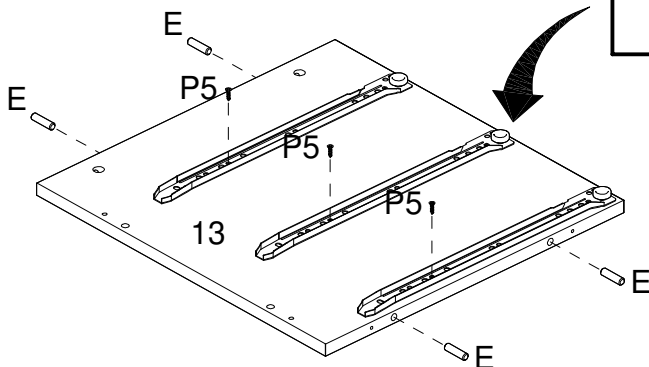

13

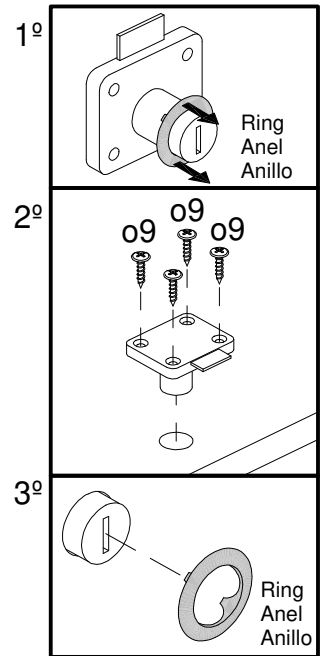
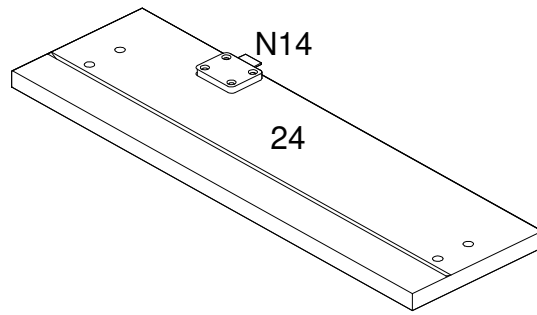

14

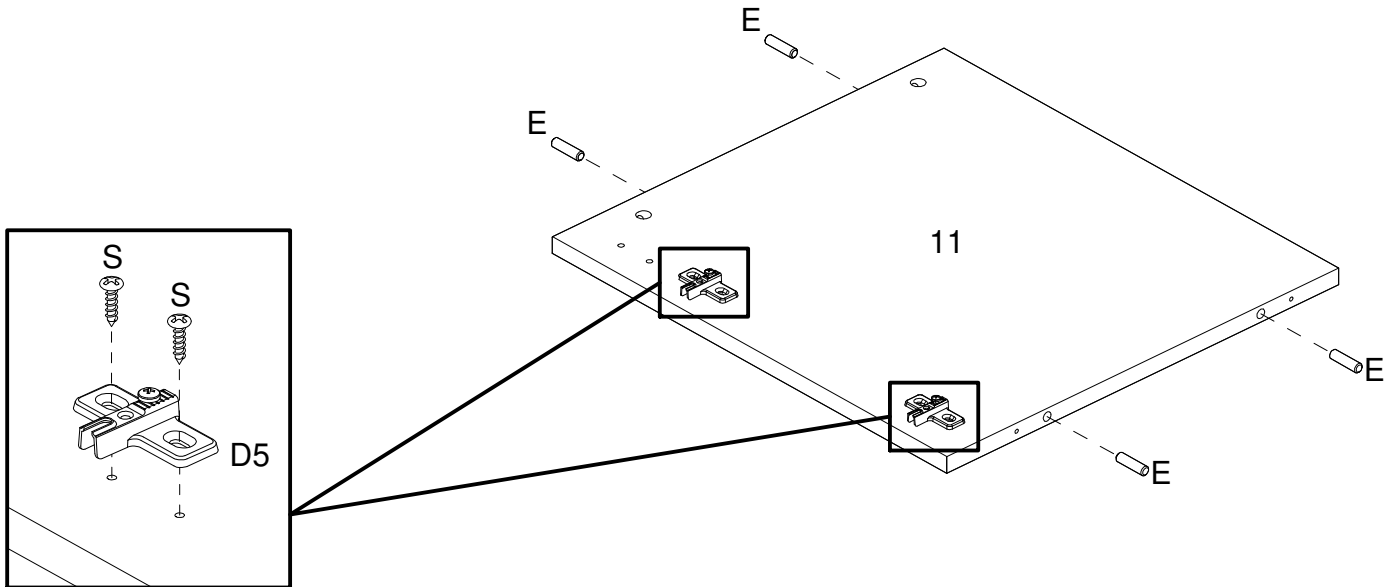

15

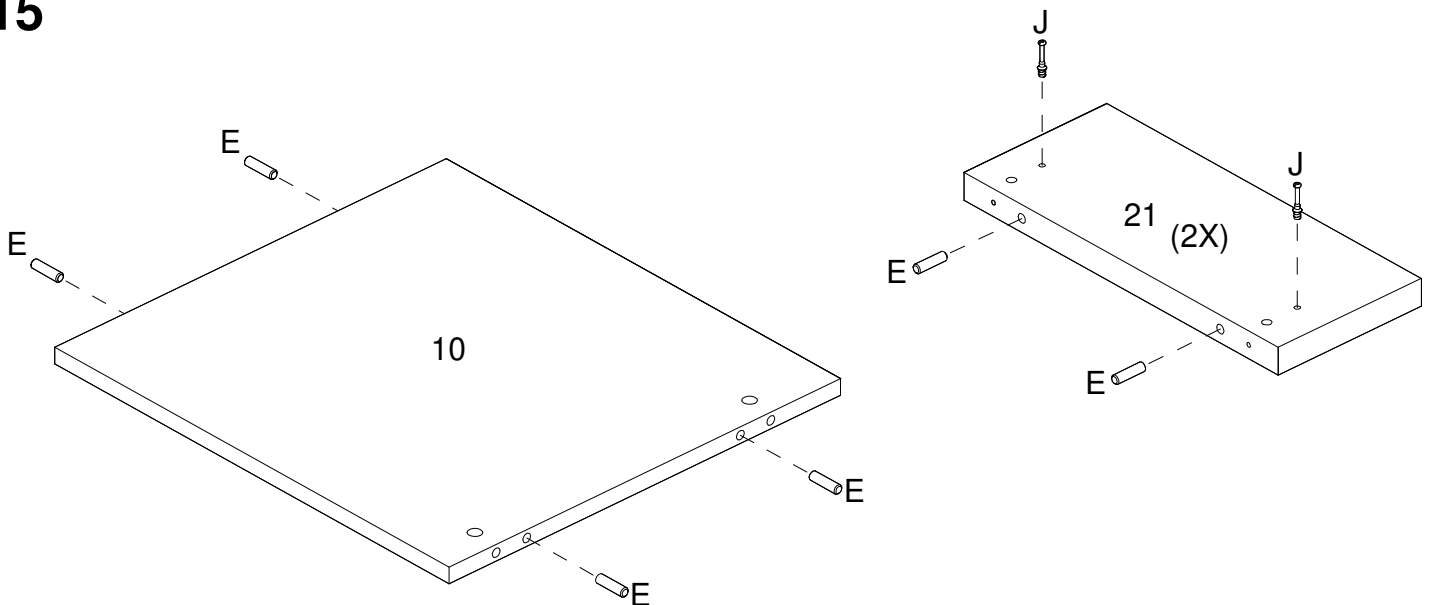

ASSEMBLY
MONTAGEM / ARMADO

16

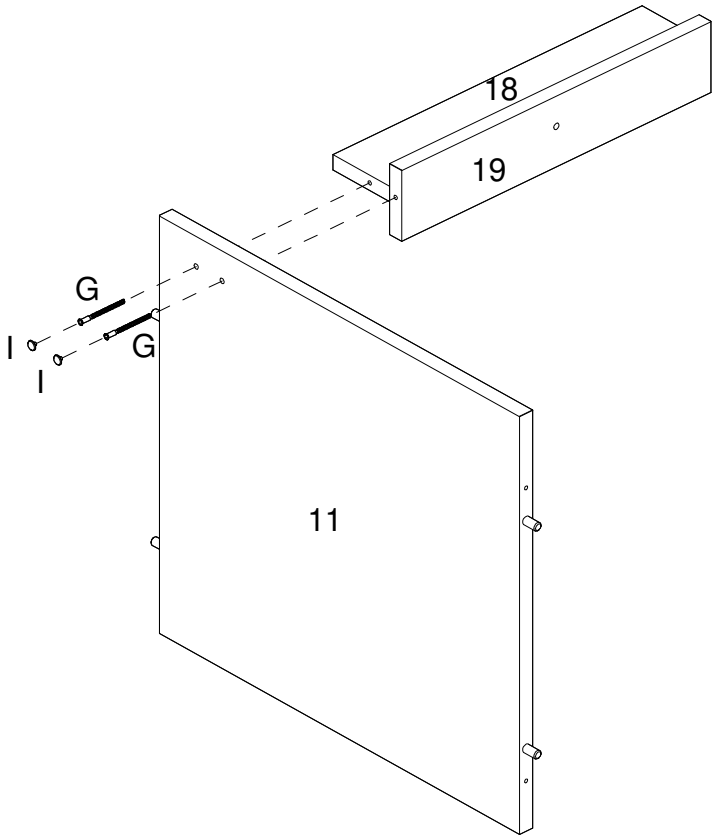
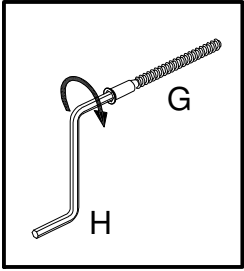

17

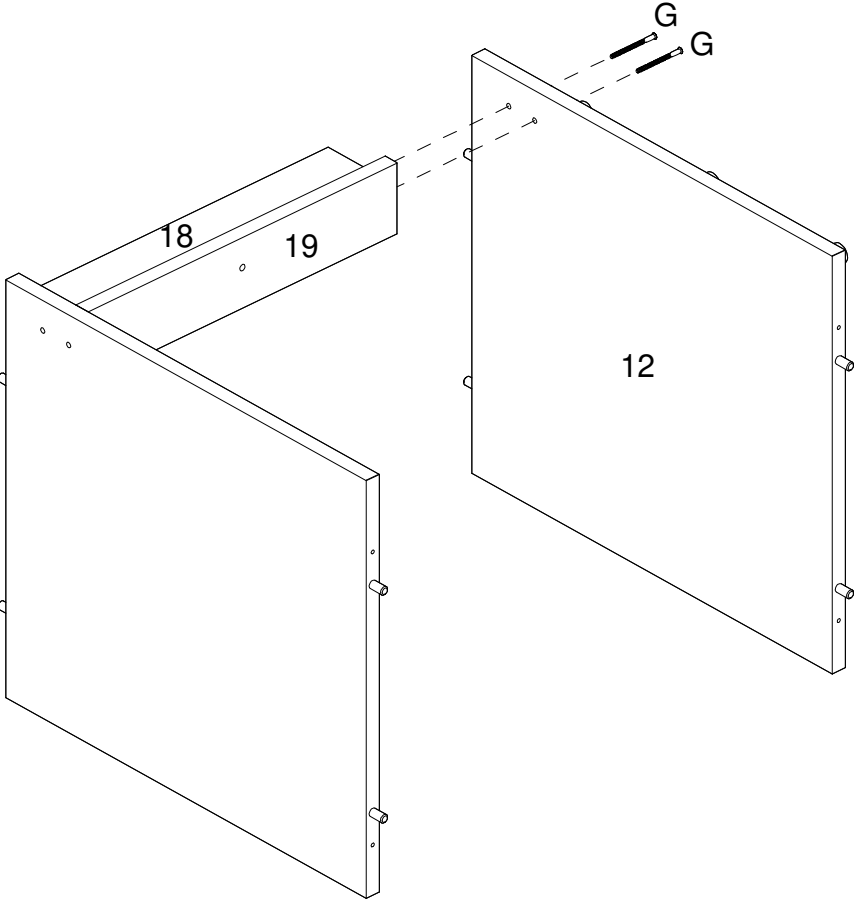

18

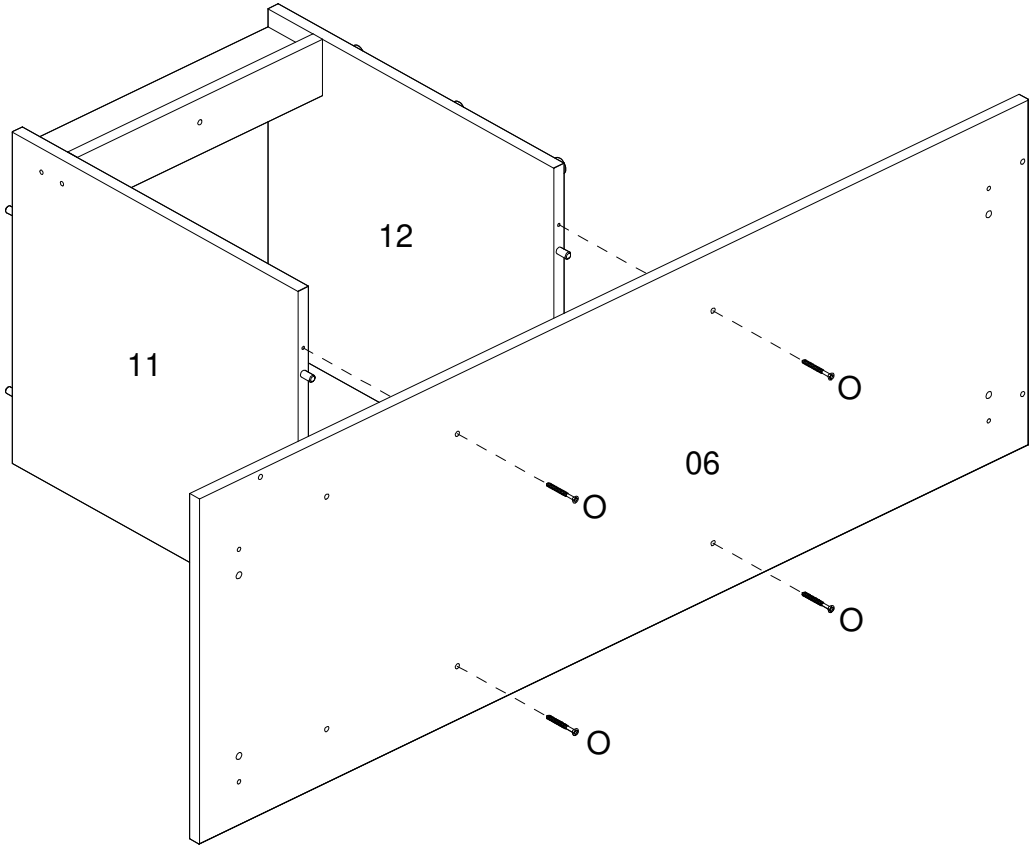

19

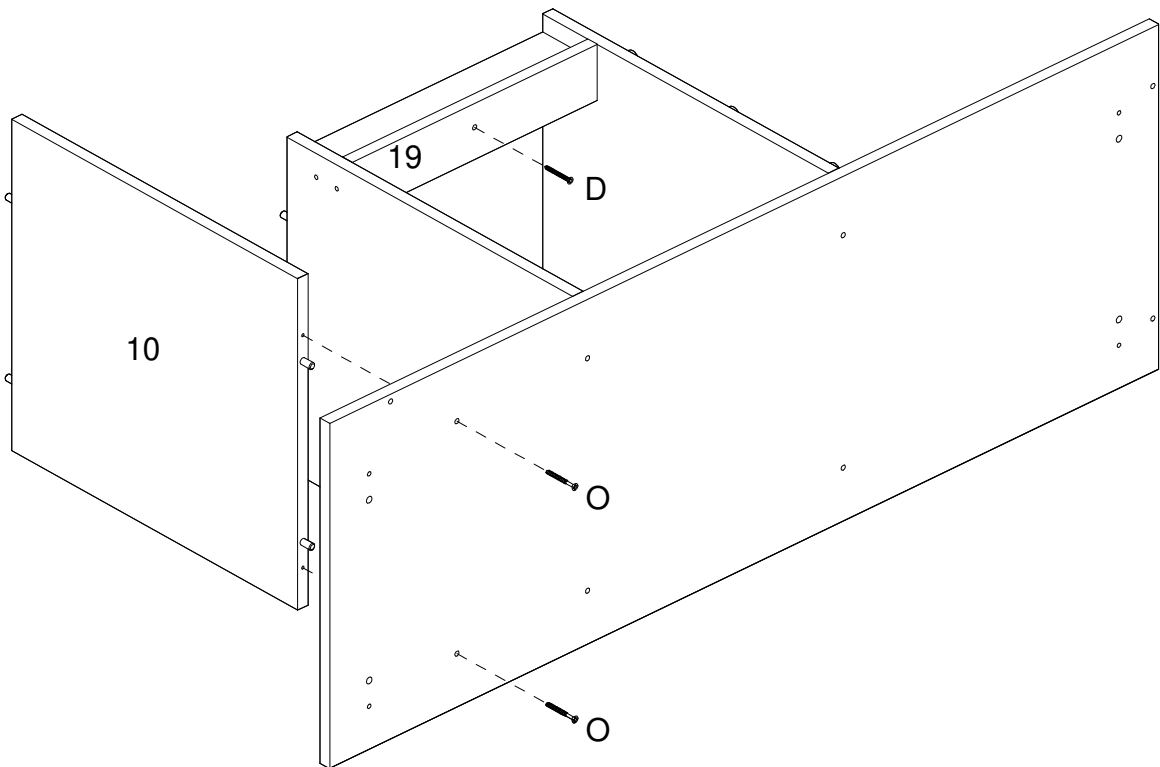

20

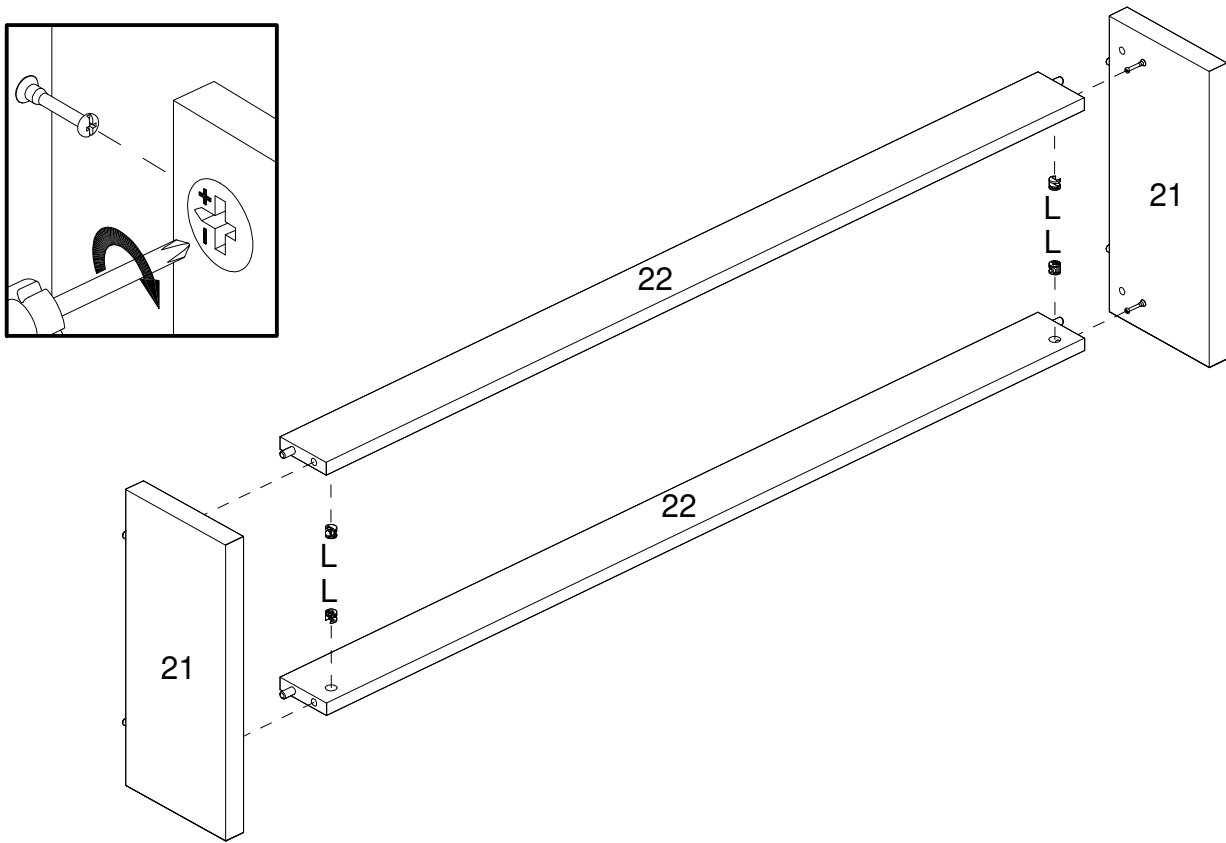

21

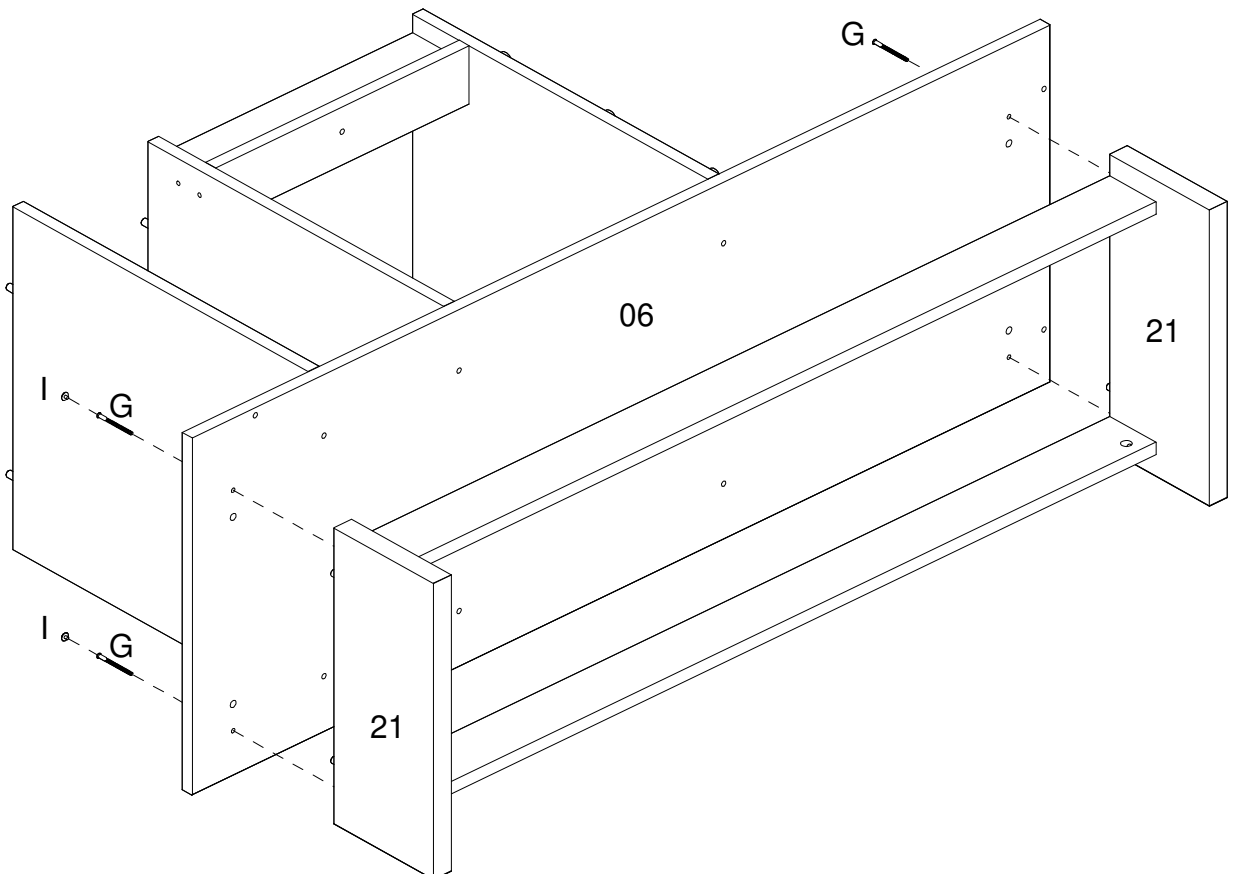

22

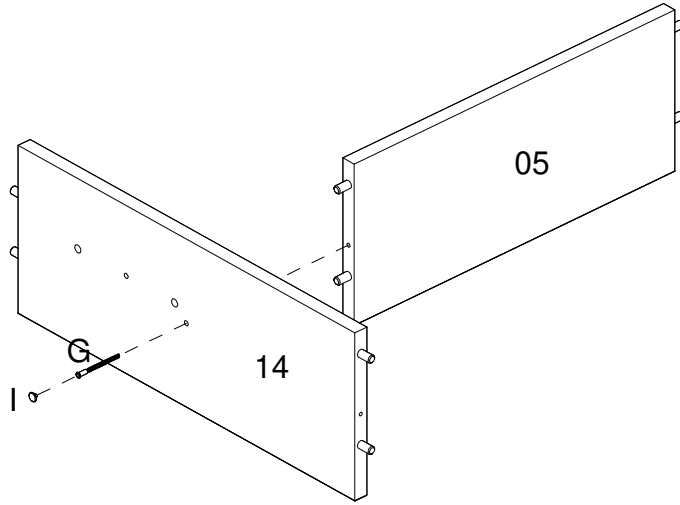

23

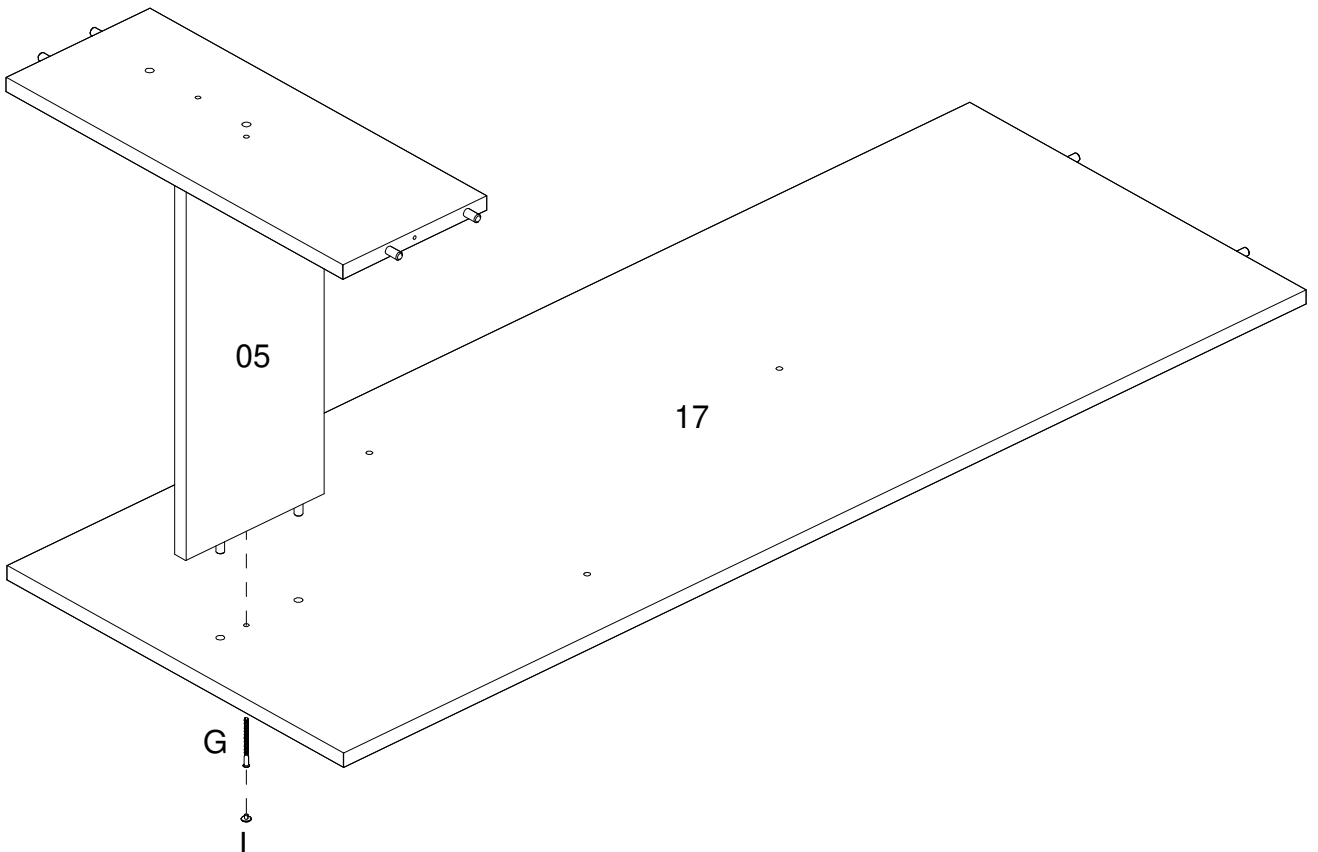

24

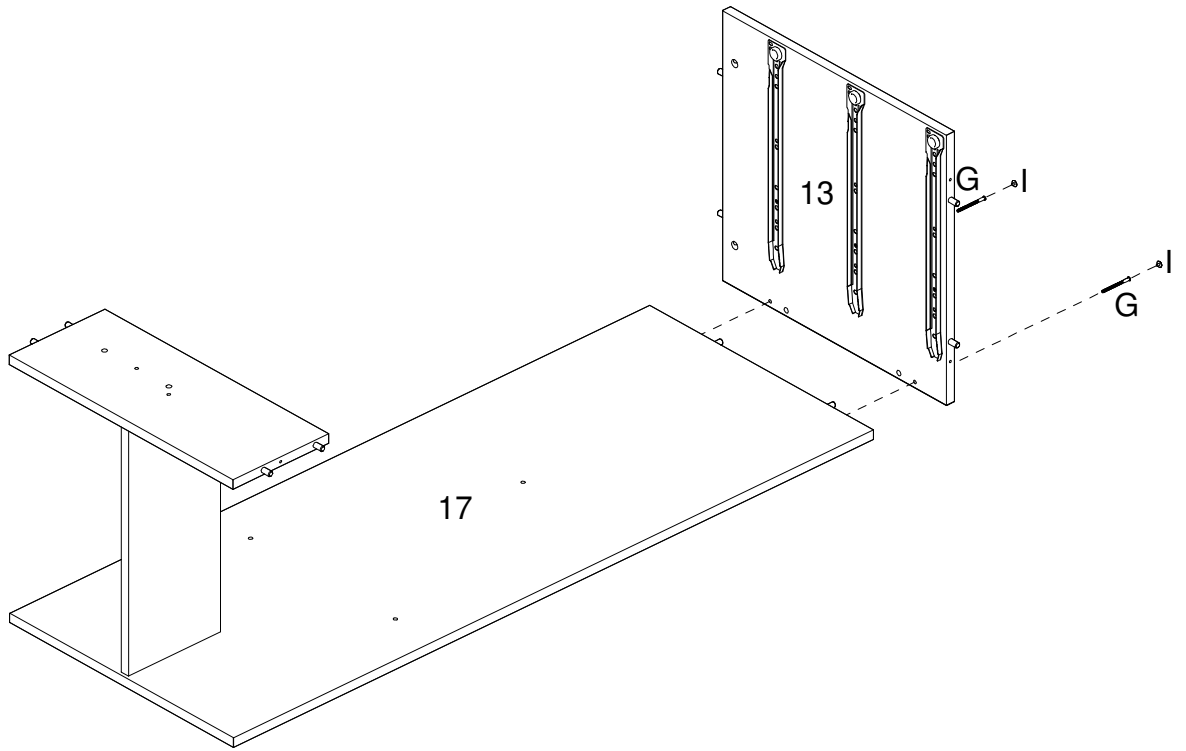

25

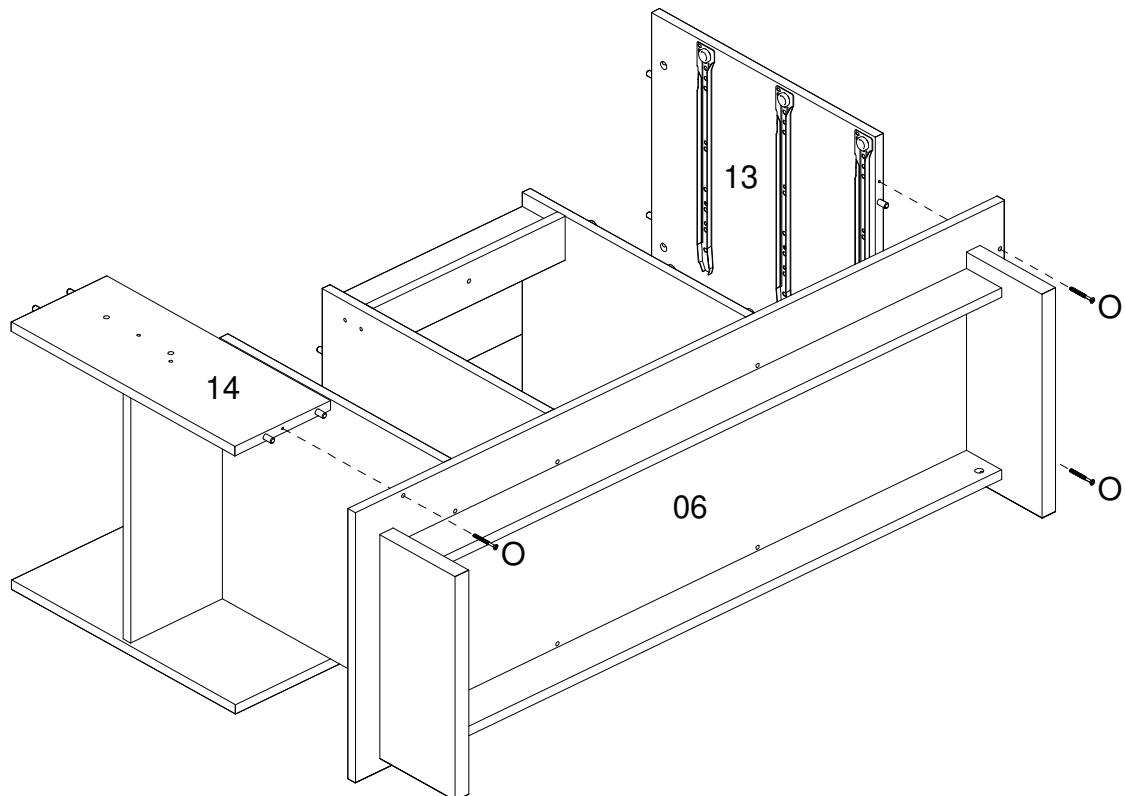

26

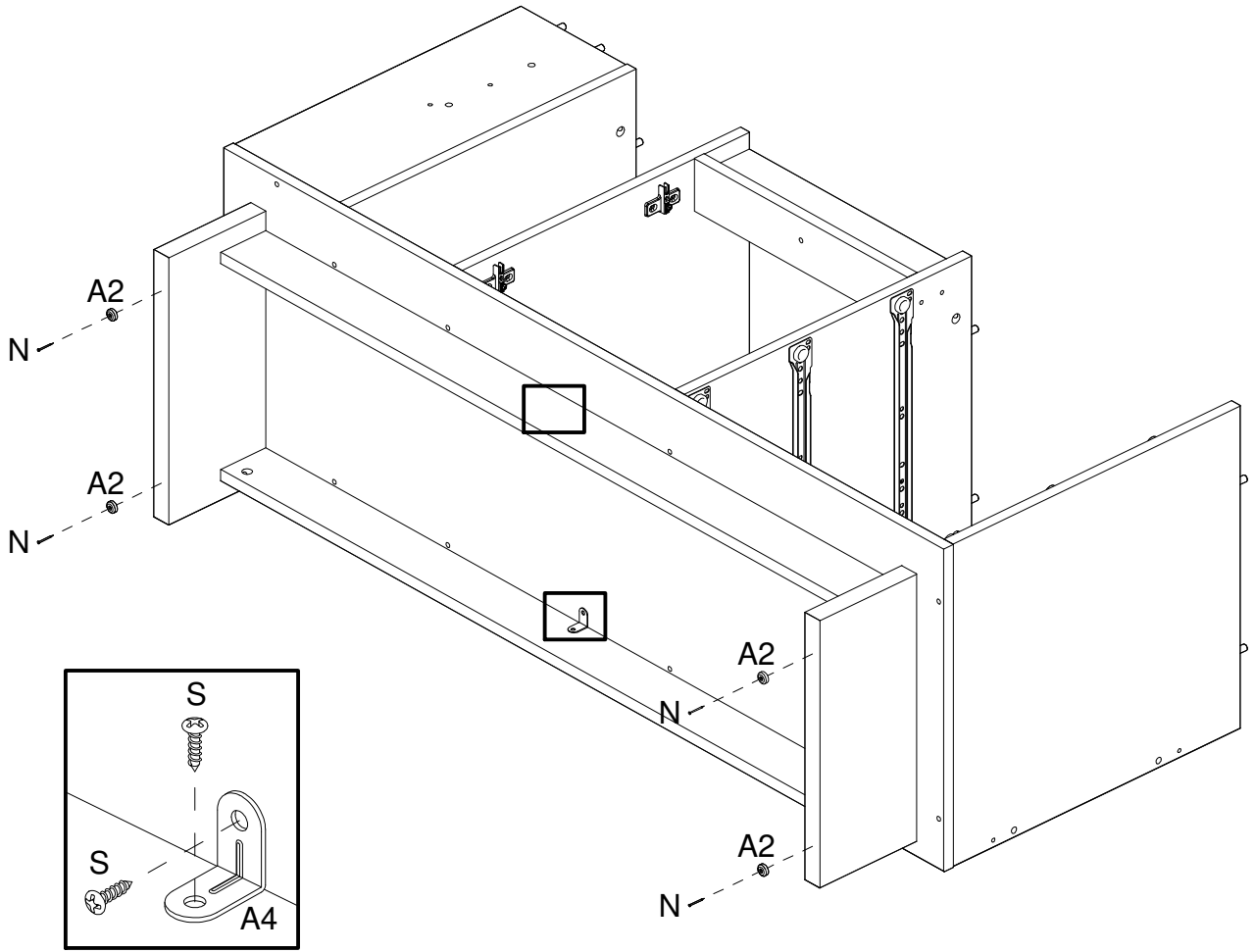

27

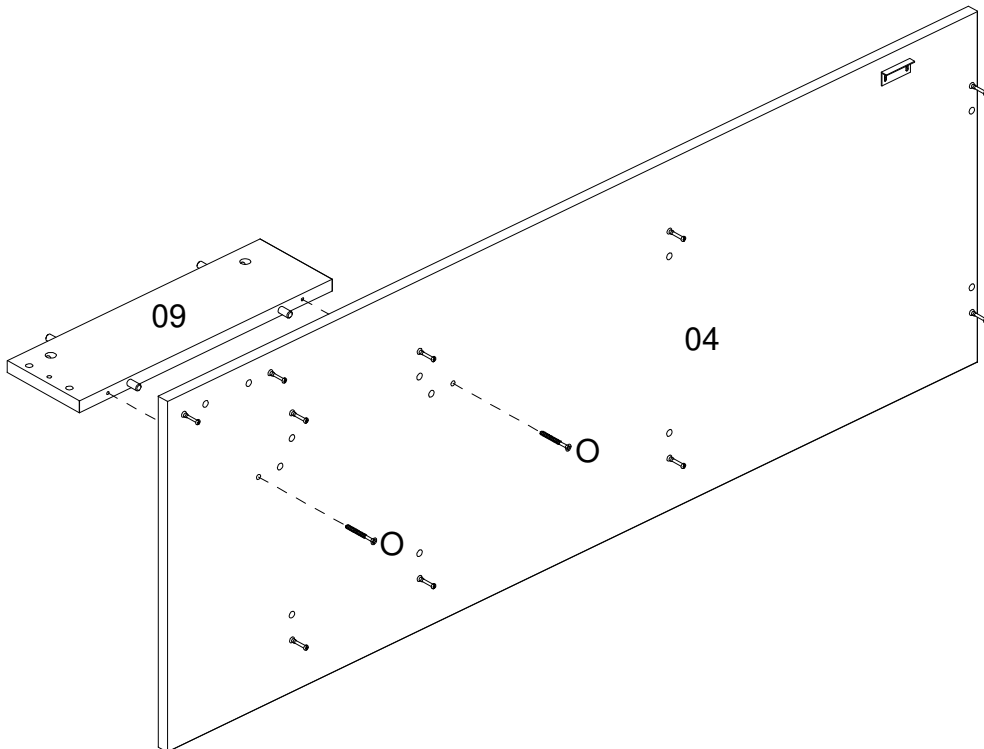

28

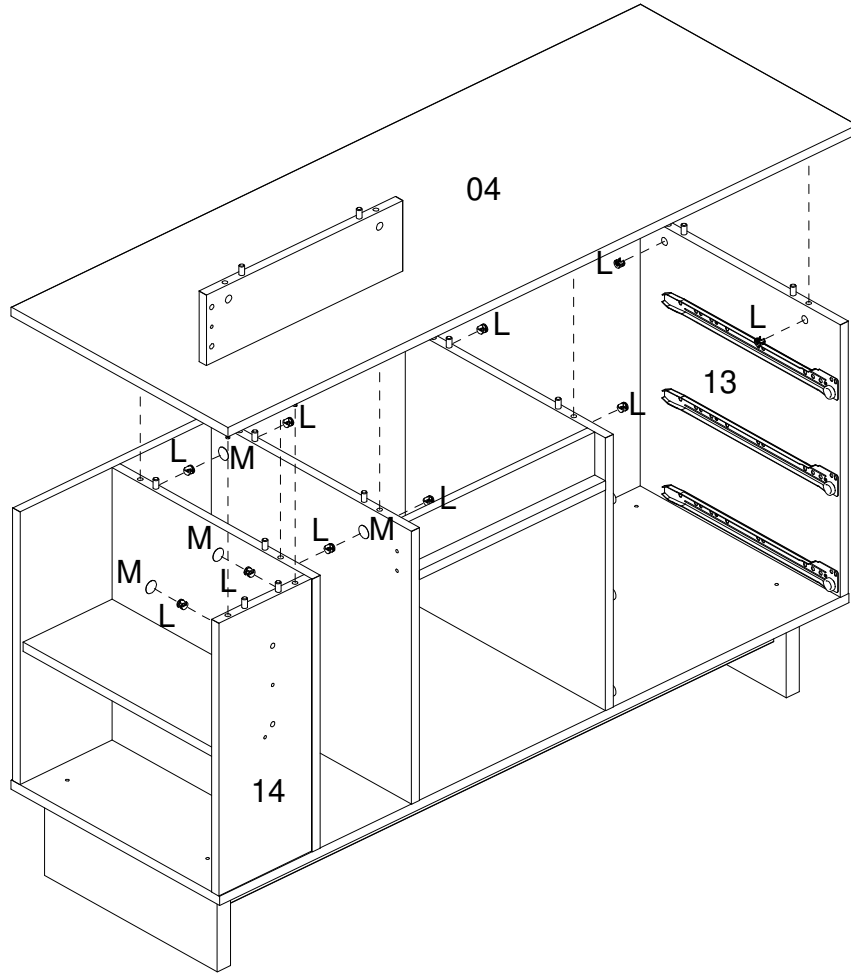

29

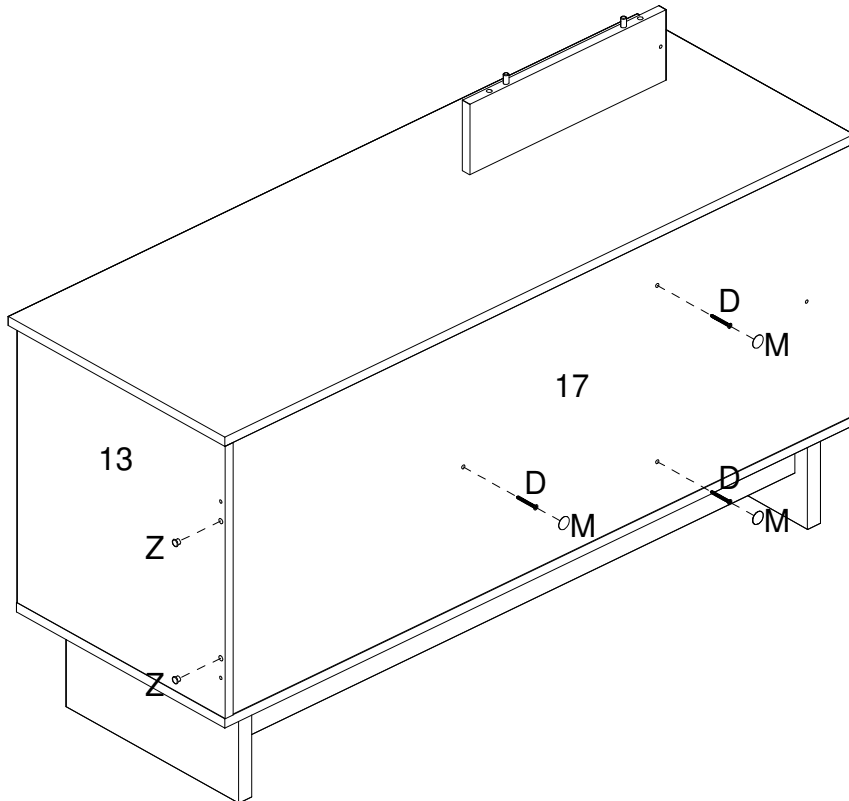

30

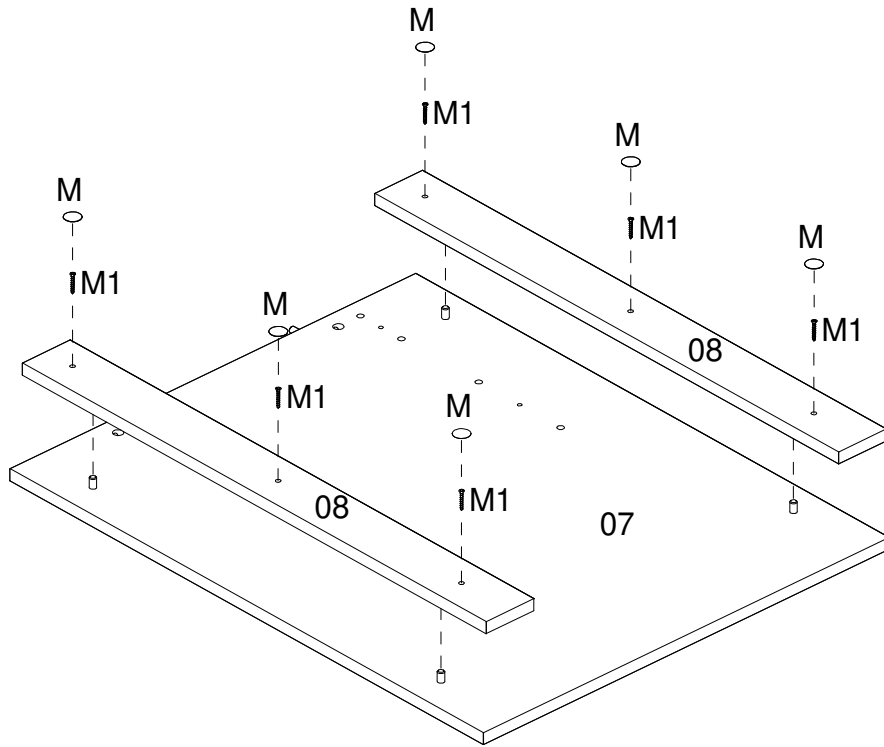

31

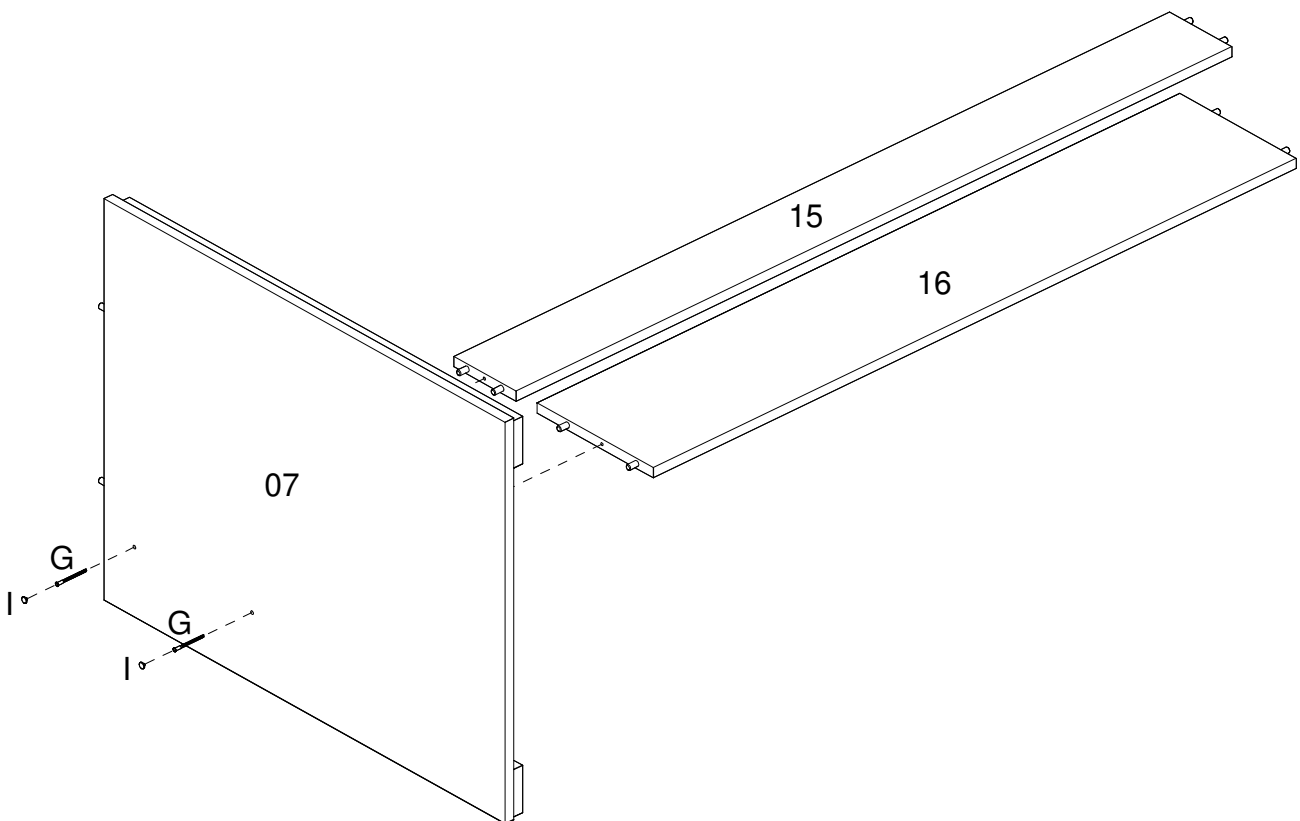

32

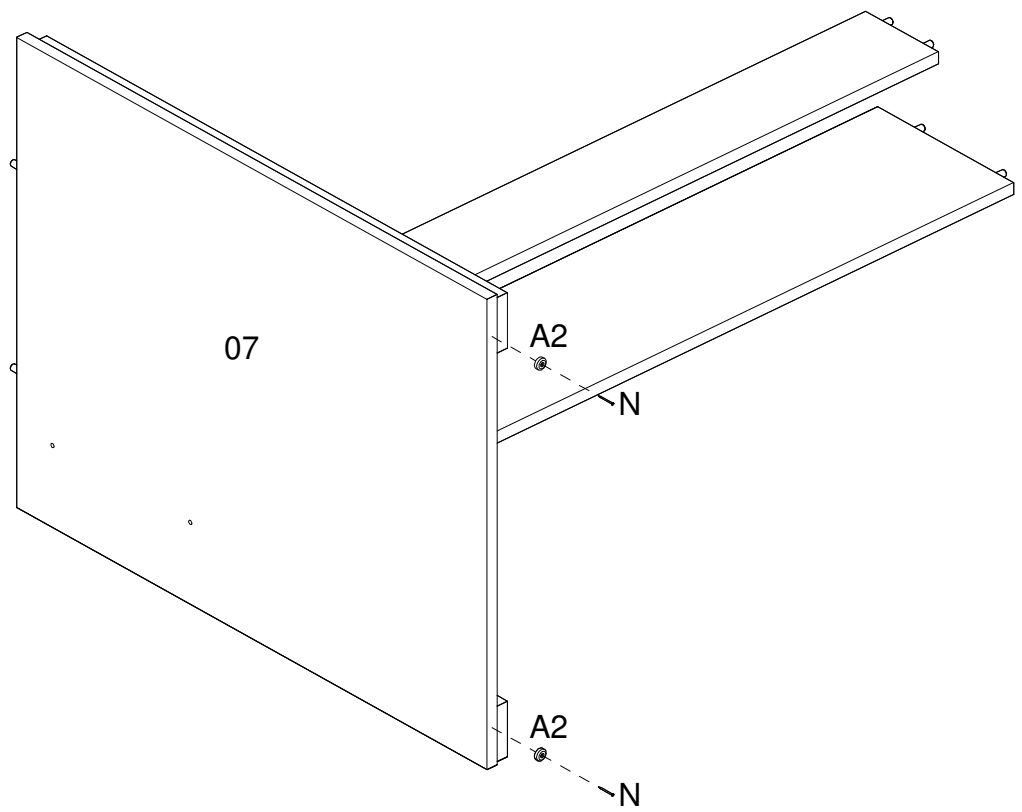

33

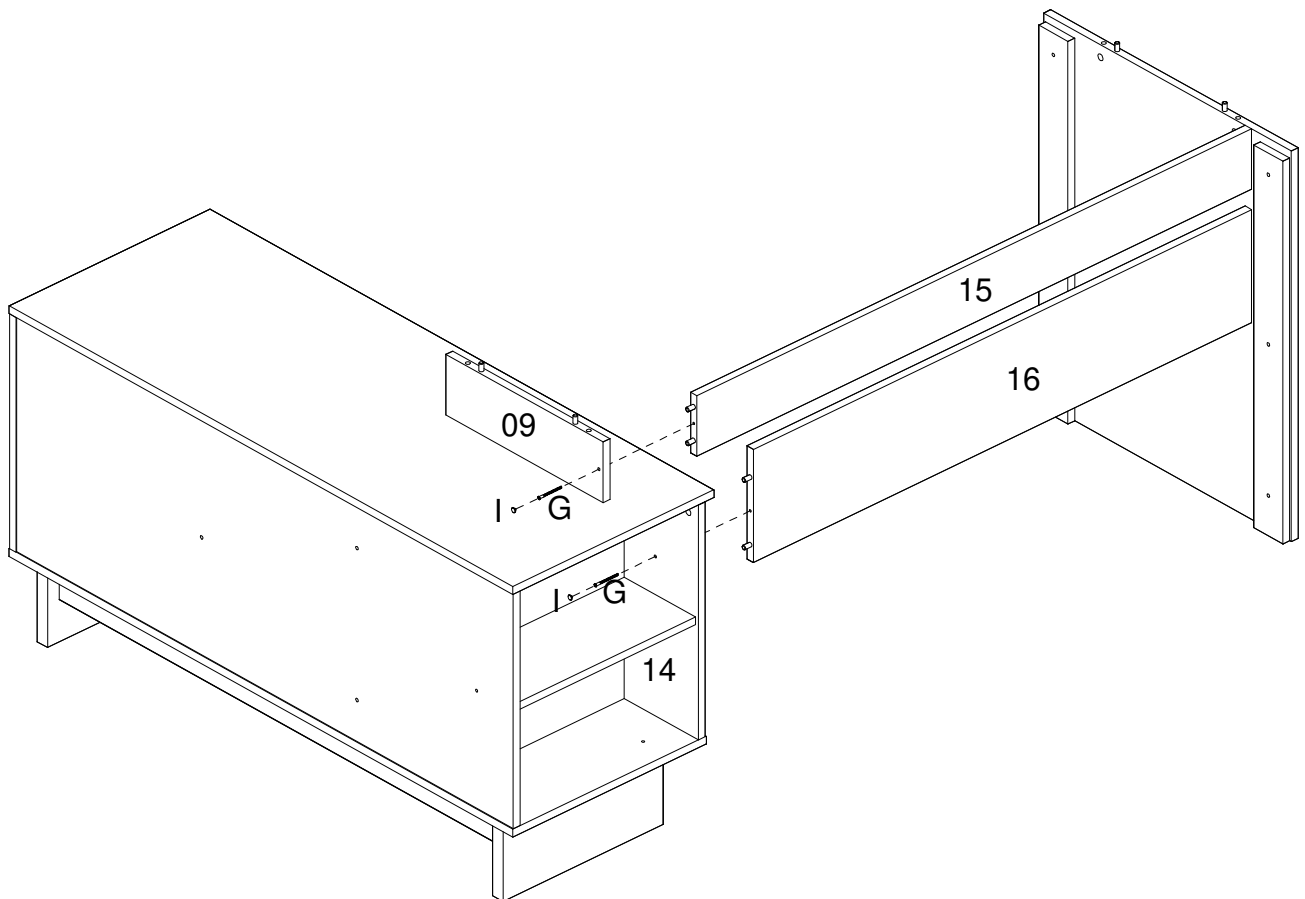

34

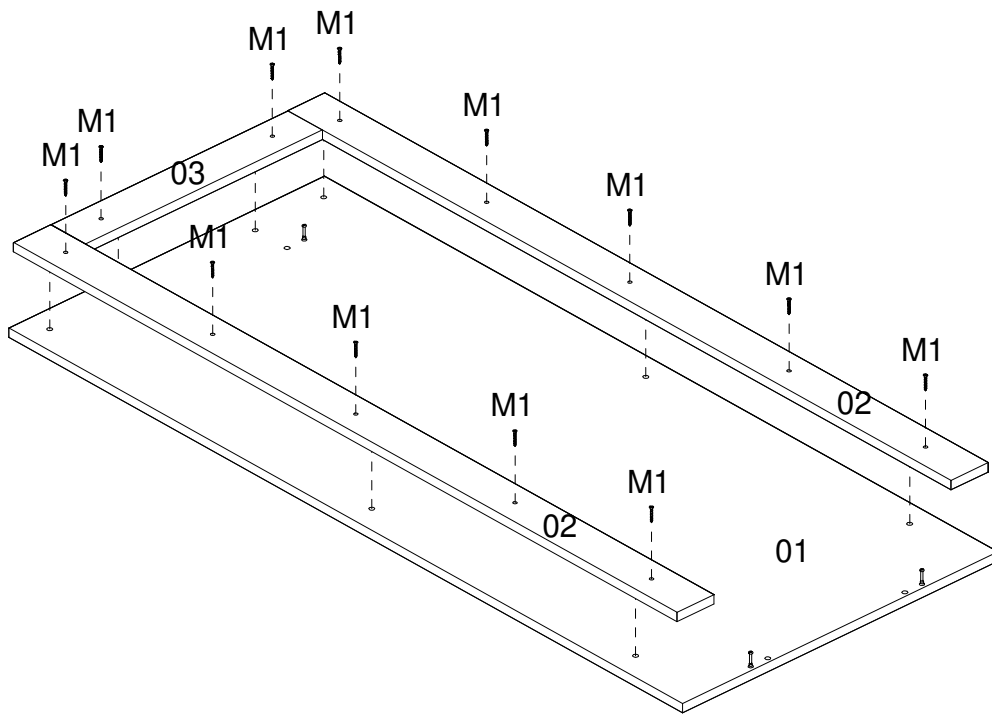

35

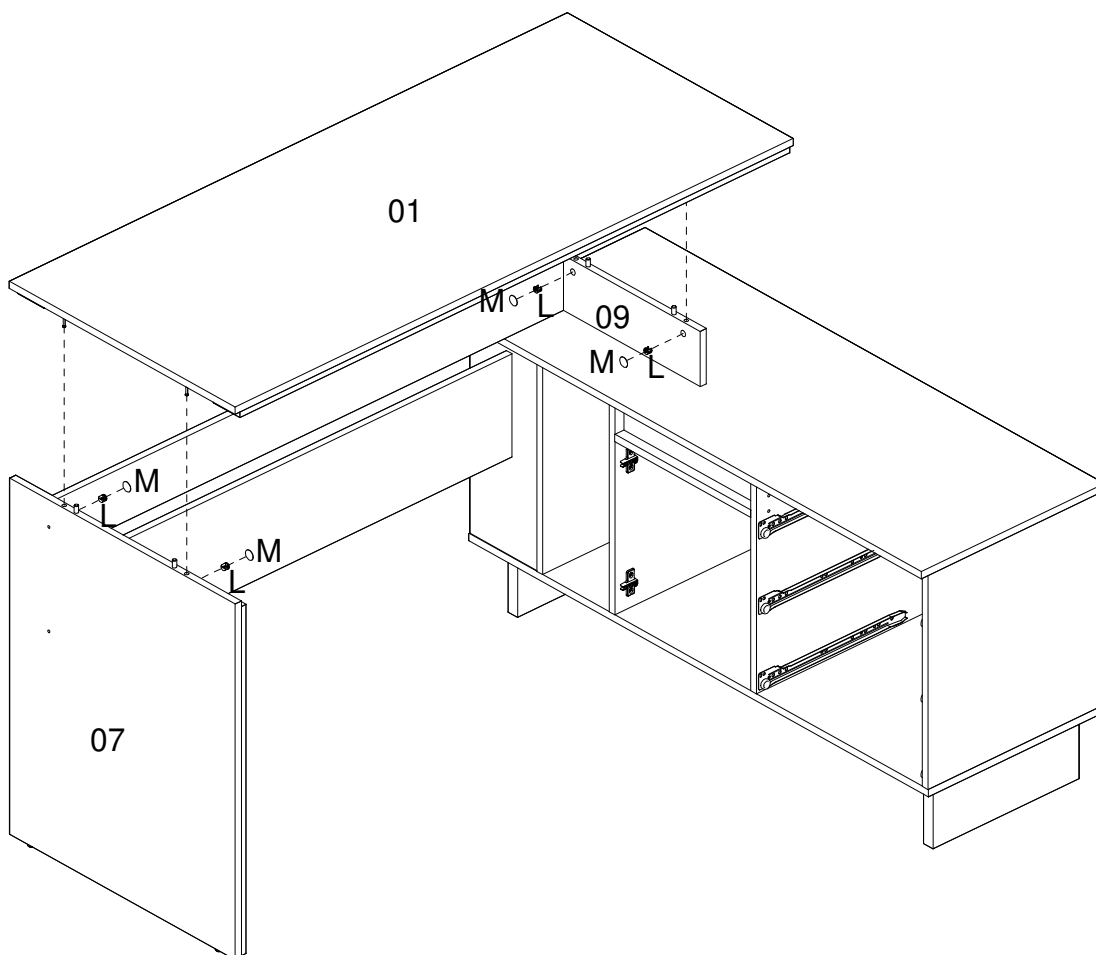

36

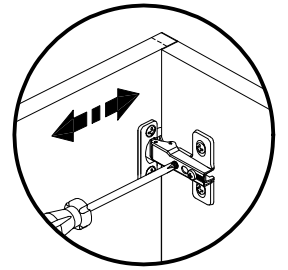
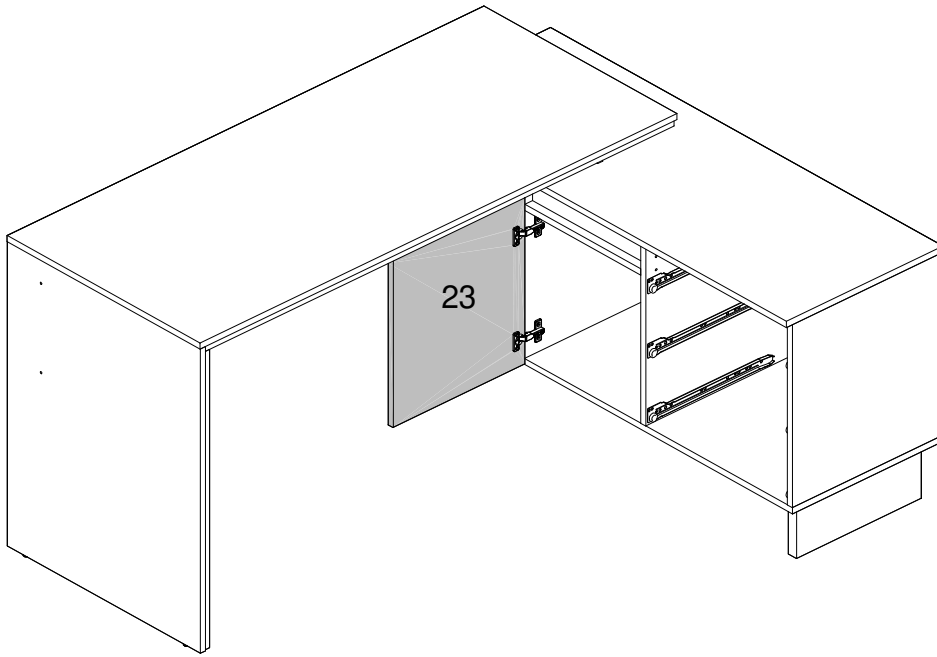

Horizontal Adjustment
Regulagem Horizontal
Ajuste Horizontal

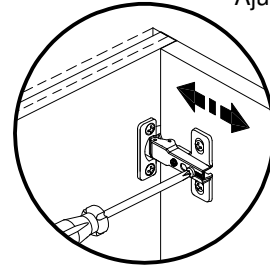

Depth Adjustment
Regulagem Profundidade
Ajuste Profundidade

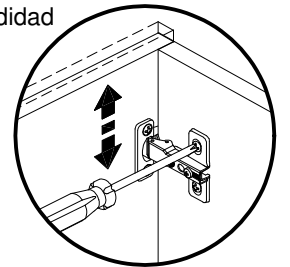

Vertical Adjustment
Regulagem Vertical
Ajuste Vertical

37

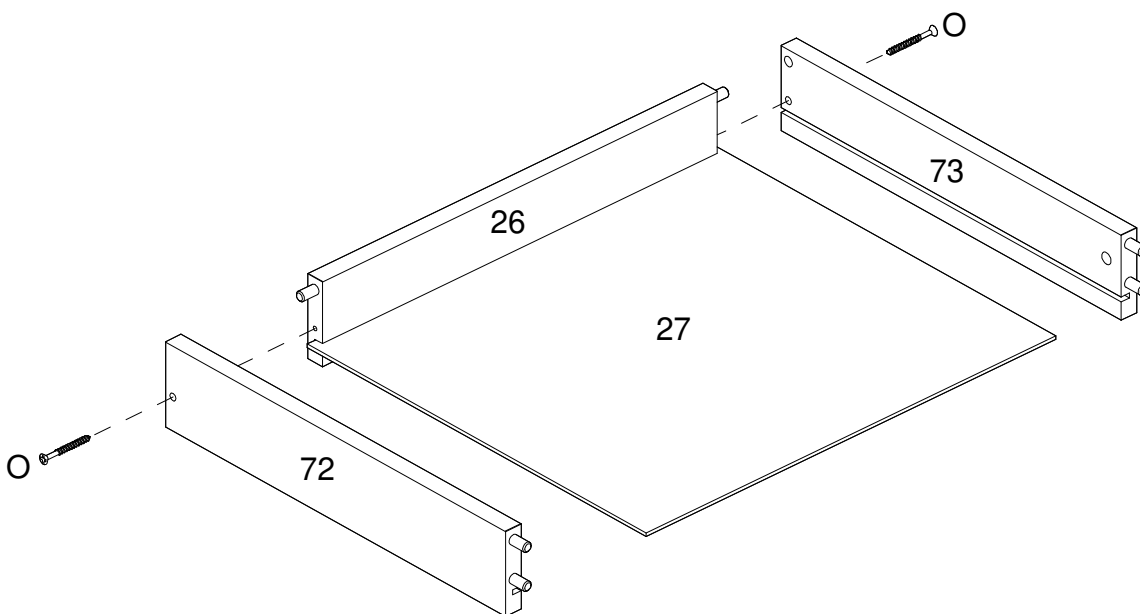

38

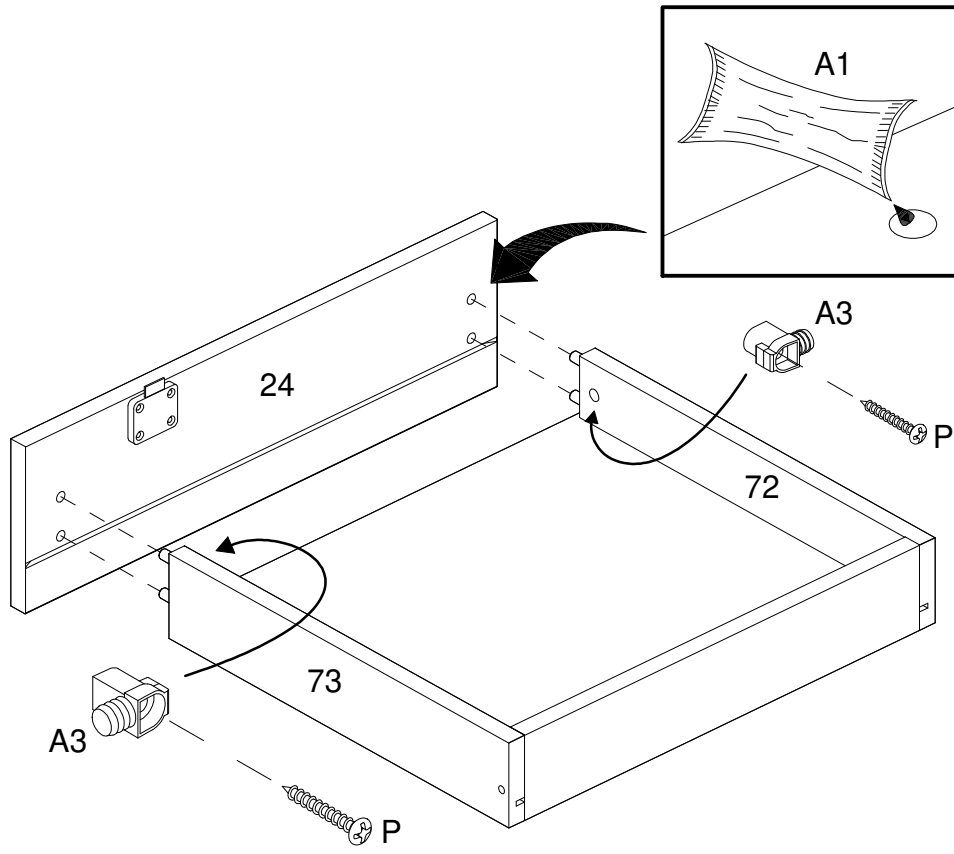

39

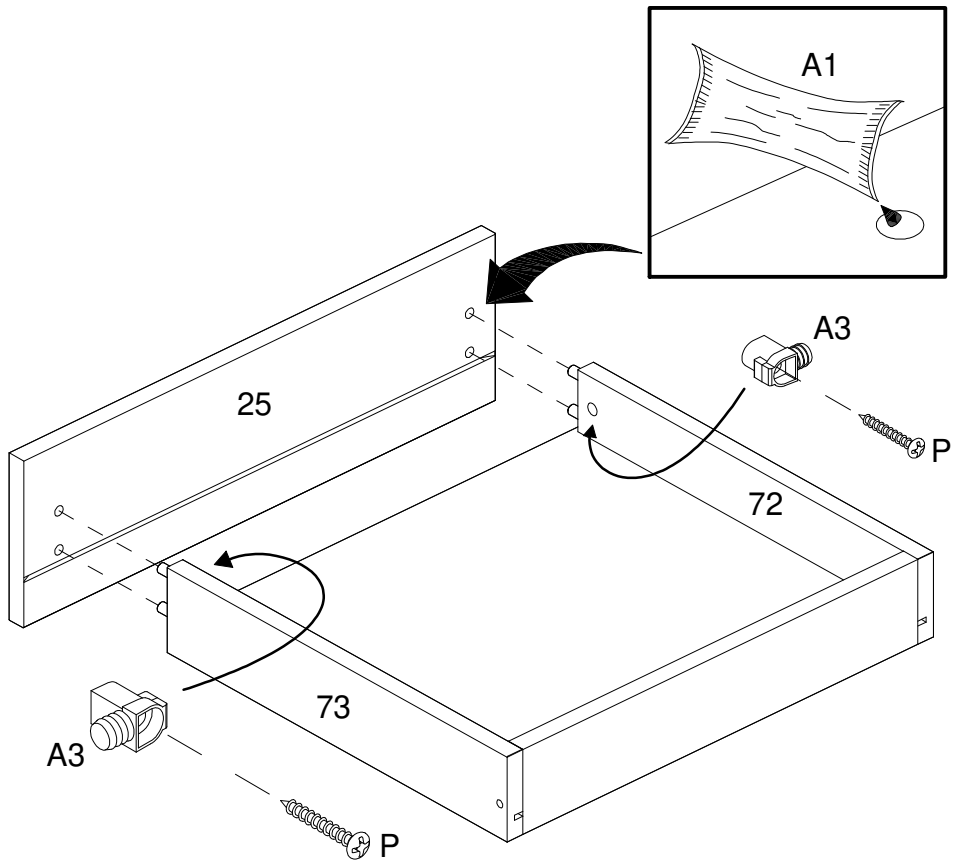

40

THE UNDERSIDE OF THE DRAWER
LADO INFERIOR DA GAVETA
PARTE INFERIOR DEL CAJÓN

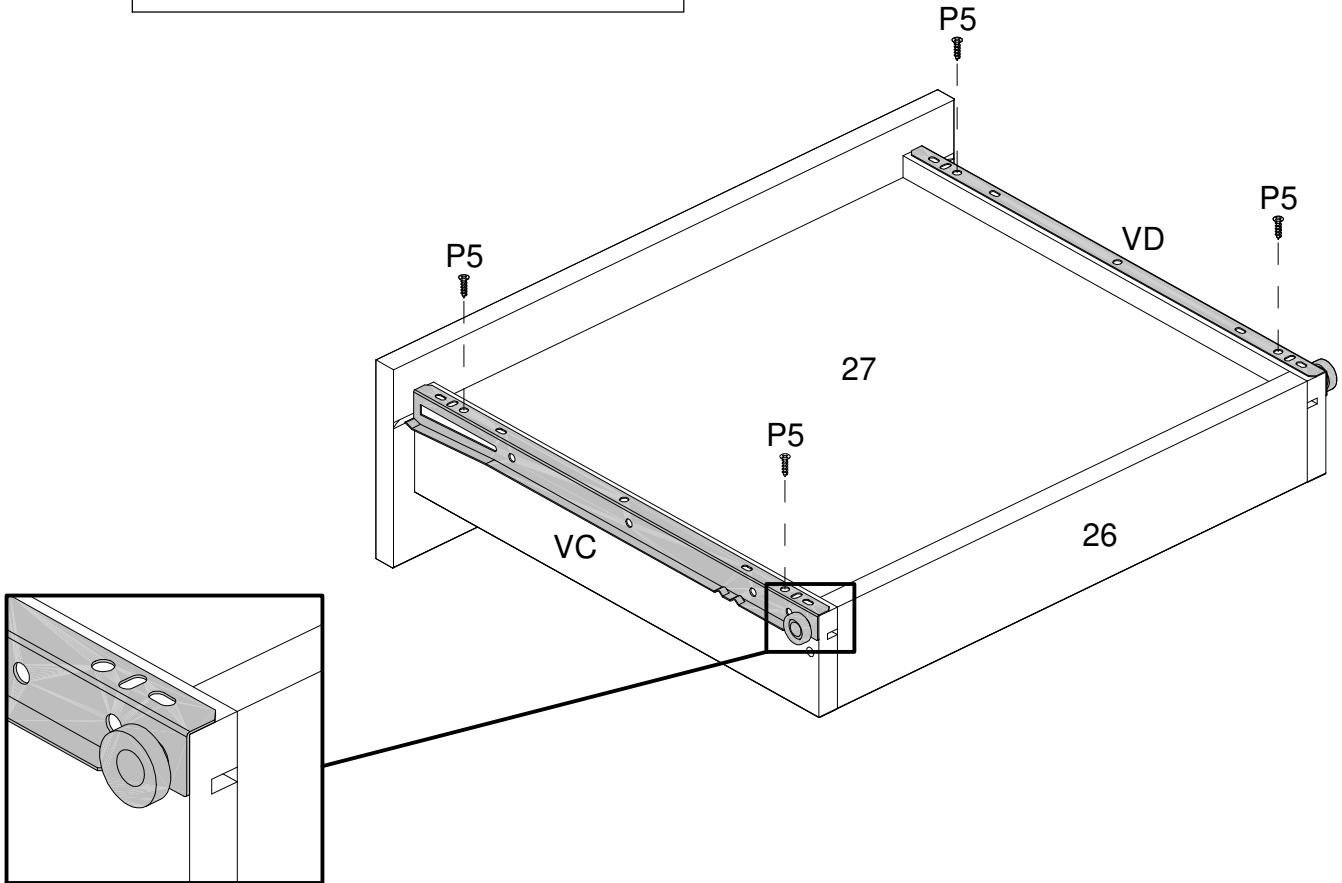

41

