

# kappesberg

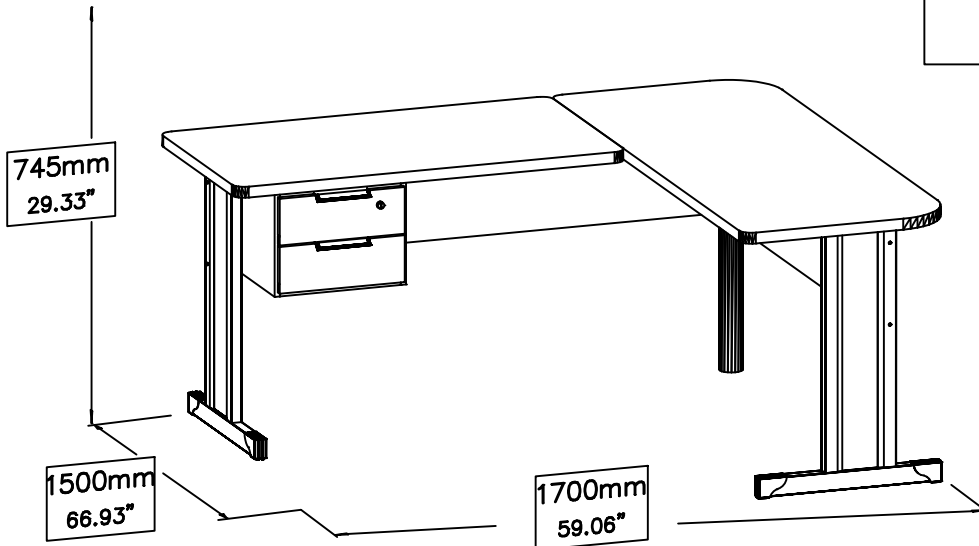

A montagem deve ser efetuada por **DUAS** pessoas.  
El montaje debe ser efectuado por **DOS** personas.  
The assembly must be done by **TWO** people.

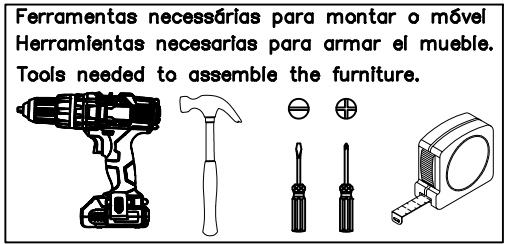
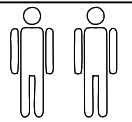

Montar o móvel sobre uma superfície limpa e plana  
Armar el mueble sobre una superficie limpia y plana  
Assemble the furniture on a clean and flat surface

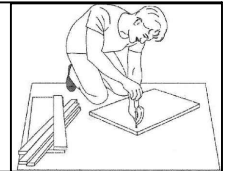

Lista de peças / Lista de piezas / List of pieces

Código / Code				Quantidade / Cantidad / Amount	Comprimento / Longitud / Length (mm)	Comprimento / Longitud / Length (In.)	Largura / Ancho / Width (mm)	Largura / Ancho / Width (In.)	Espessura / Espesor / Thickness (mm)	Espessura / Espesor / Thickness (In.)	Caixa / Caja / Box
01	Tampo maior	Top más grande	Bigger top	1	1496	11.46"	596	23.46"	30	.59"	A
02	Tampo menor	Top más pequeña	Lower Top	1	1096	11.46"	596	23.46"	30	.59"	A
03	Reforço maior	Mayor refuerzo	Greater reinforcement	1	1385	13.86"	293	11.54"	15	.59"	A
04	Reforço menor	Refuerzo menor	Minor reinforcement	1	1186	13.39"	293	11.54"	15	.59"	A
05	Enchimento do pé	Laterales	Sides	2	675	14.17"	128	5.04"	15	.59"	A
06	Lateral direita	Lateral derecha	Right side	1	291	11.22"	397	15.63"	15	.59"	A
07	Lateral esquerda	Lateral izquierda	Left side	1	291	14.09"	397	15.63"	15	.59"	A
08	Frente de gaveta superior	Frente del cajón superior	Top drawer front	1	352	13.39"	126	5.04"	15	.59"	A
09	Frente de gaveta inferior	Frente del cajón inferior	Lower drawer front	1	352	13.39"	126	5.04"	15	.59"	A
10	Lateral de gaveta dir.	Lateral de cajón derecha	Right drawer side	2	360	54.53"	89	3.50"	15	.59"	A
11	Lateral de gaveta esq.	Lateral de cajón izquierda	Left drawer side	2	360	46.69"	89	3.50"	15	.59"	A
12	Cabeceira de gaveta	Cabecera de cajón	Back drawer	2	285	58.90"	89	3.50"	15	.59"	A
13	Sarrafo inf. das gavetas	Marco inferior de los cajones	Lower slat of drawers	1	340	43.15"	64	2.52"	15	.59"	A
14	Sarrafo sup. e tras..	listón superior e inferior	Upper and lower slat	2	340	26.57"	64	2.52"	25	.98"	A
15	Fundo de gaveta	Fondo de cajón	Bottom drawer	2	358	2.52"	298	11.73"	3	.12"	A
22	Apoio do tampo	Soporte superior	Top support	2	64	2.52"	64	2.52"	15	.59"	A

## 1170A

## IDENTIFICAÇÃO DOS ACESSÓRIOS/ IDENTIFICACIÓN DE ACCESORIOS/ IDENTIFICATION OF ACCESSORIES



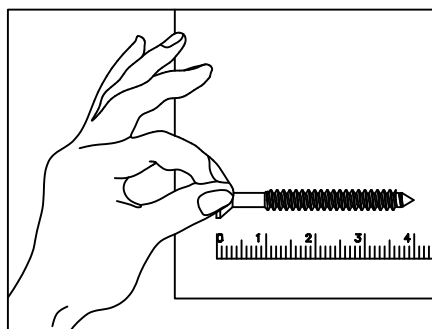

–NOTAS: A separação dos acessórios antes de iniciar a montagem facilitará a mesma. Os parafusos e cavilhas estão na escala real. Em caso de dúvida na identificação, coloque o acessório sobre a imagem.

–NOTAS:La separación de los accesorios antes de comenzar el armado facilitará el mismo. Los tornillos y taquetes son en escala real. En caso de dudas sobre la identificación, coloque el accesorio en la imagen.

–NOTES:The separation of the accessories before you start the assembly will facilitate the same. The screws and dowels are in real scale. In case of doubts about the identification, place the accessory on the image

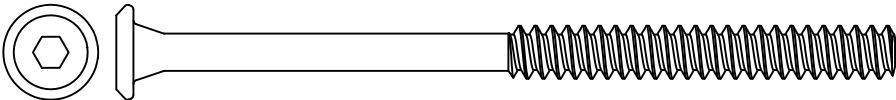
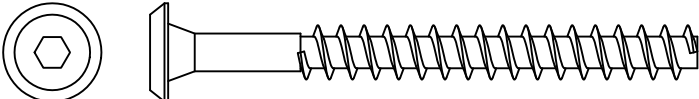
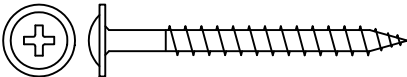
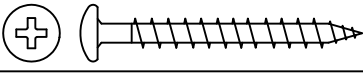

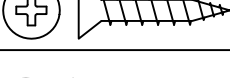
## Ferragem / Herrajes / Hardware

	Código/ Código/ Code	Descrição / Descripción / Description	Quan./ Cant./ Amou.
PE9	2336	 Parafuso estrutural/ Tornillo estructural/Structural screw 7x100	4
PE12	1260	 Parafuso estrutural/ Tornillo estructural/Structural screw 7x70	4
PF7	4042	 Parafuso/ Tornillo/ Screw 4x40 ZP	12
PP6	414	 Parafuso/ Tornillo/ Screw 4,0X35	4
PF4	1178	 Parafuso/ Tornillo/ Screw 3,5x16	4
PC5	5256	 Parafuso/ Tornillo/ Screw 4X20	4
PC3	4214	 Parafuso/ Tornillo/ Screw 3,5X14	60
C1	1802	 Cavilha/Tarugo/Dowel 6x30mm	14

## Prezado Montador:

– Antes de iniciar a montagem verifique as condições do ambiente de montagem;  
– Confira todas as peças das embalagens com a lista de peças contida neste manual;  
– Separe os acessórios, confira as medidas dos parafusos com a escala;  
– Siga todas as orientações deste manual de montagem para ter o direito à garantia do produto;  
– Descarte as embalagens de forma correta, destinando o plástico e o papel para reciclagem;





## Estimado Montador:



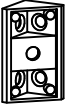
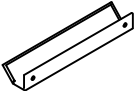
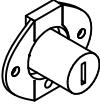
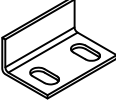
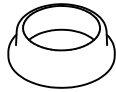

– Antes de iniciar a montagem verifique as condições do ambiente de montagem;  
– Confira todas as peças das embalagens com una lista de peças contida neste manual;  
– Separe os acessórios, confira as medidas dos parafusos com a escala;  
– Siga todas las orientaciones deste manual de montaje para ter o direito à garantia do produto;  
– Descarte como embalagens de forma correta, destinando o plástico e o papel para reciclagem;

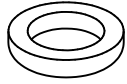
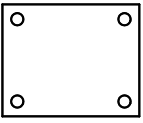
## Dear Fitter:

– Before starting montagem check as conditions of the assembly environment;  
– Check out all the packaging com a list of fish contained in this manual;  
– Separate the accessories, check the measures two parafuses com to scale;  
– Follow all the guidelines of this manual montagem for ter or direct to guarantee of the product;  
– Discard the packages correctly, allocating either plastic or paper for recycling;

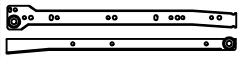
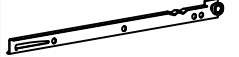
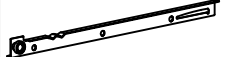

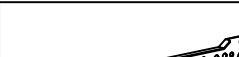
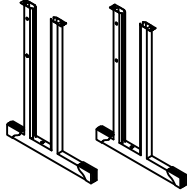
Ferragem / Herrajes / Hardware			
	Código/ Código/ Code	Descrição / Descripción / Description	Quan./ Cant./ Amou.
CG	899	 Cantoneira/Cantón/angle bracket	5
PX	63804	 Puxador/Manija del cajón/Andle	2
F	1620	 Fechadura com chave/Cerradura puerta/Door lock	1
LE	1622	 "L" de engate/Kit de cerradura/Lock kit	1
SA2	2030	 Sapata externa/Zapato externo/External shoe	1
CZ1	248	 Chave Allen/ Llave Allen/ Allen key 1/4"	1
CPL	IT=40671 (Preto)	 Tampa CPL/ Tapa CPL/ CPL cover 13mm	8
UT	1454	 União de metal/Unión de metal/ Metal union	2
EM	58	 Etiqueta marca/Tag label "Kappesberg"	1
S5	18458	 Suporte triangular preto/Soporte triangular negro/Black triangular support	4

CM1	169		Corrediça de metal/Corredera de metal/Metal slide 350mm	2
CM1A			Corrediça gaveta direita/Corredera derecha cajón/Drawer slide right	
CM1B			Corrediça gaveta esquerda/Corredera del cajón izquierdo/Drawer left slide	
CM1C			Corrediça lateral esquerda/Metallic slide the left filed/Corredera lateral izquierda	
CM1D			Corrediça lateral direita/Metallic slide the right filed/Corredera lateral derecha	
PZ	59615		Pé da mesa/Pie de mesa/Table foot (Par)	1
PC	59640		Pé cilíndrico/Pie cilíndrico/Cylindrical foot	1
CB	41		Cola branca em bisnaga/Cola blanca/White glue (10g)	1

## 1170A

IDENTIFICAÇÃO DAS PEÇAS/ IDENTIFICACIÓN DE LAS PIEZAS/ PARTS IDENTIFICATION

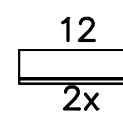
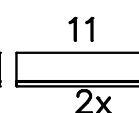
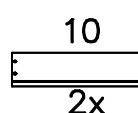
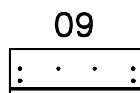
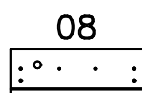
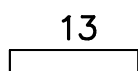
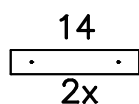
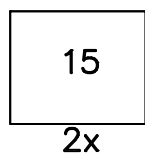
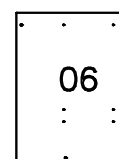
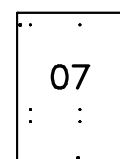
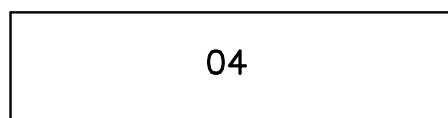
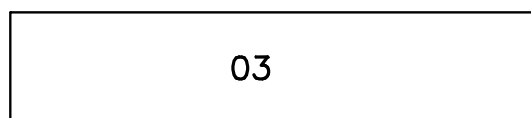
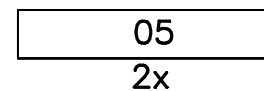
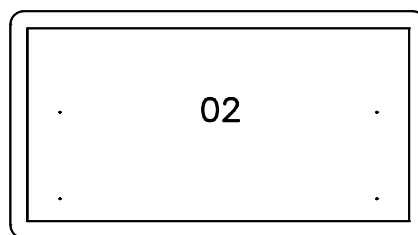
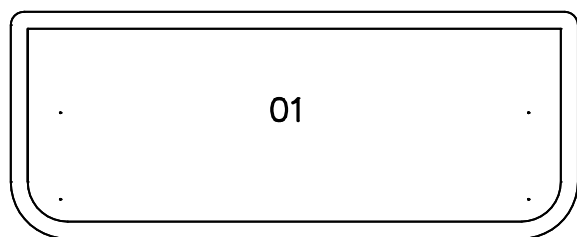

NOTE: Este produto pode ser montado para a sua esquerda ou direita.

NOTES: Este producto puede ser montado para a sua esquerda ou direita.

NOTAS: This product can be mounted to your left or right.

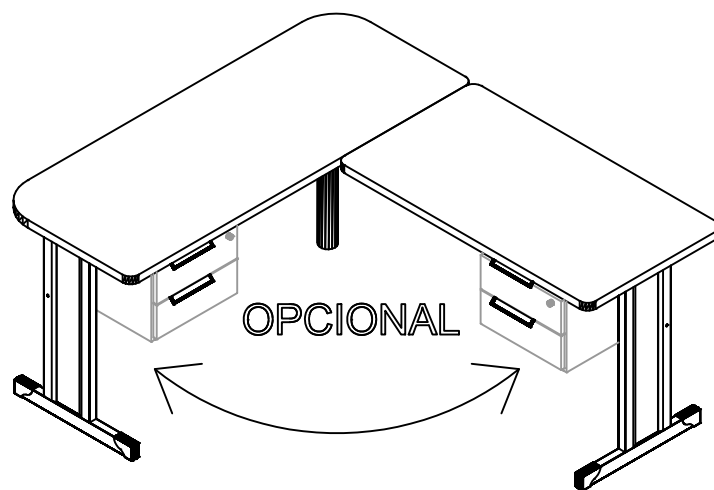
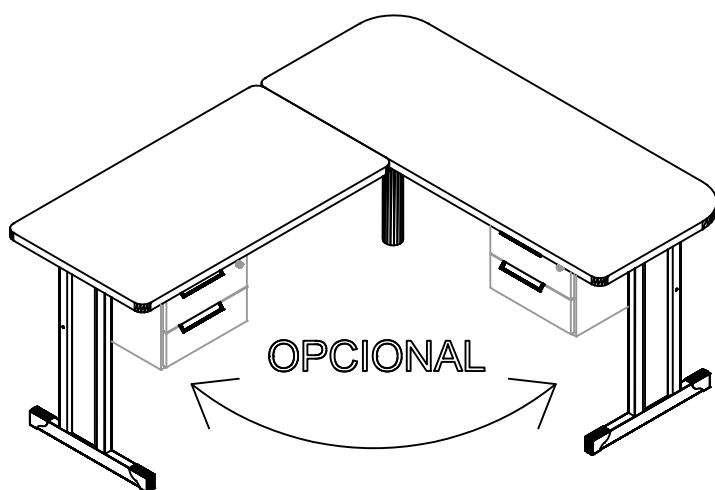

# 1170A

06/14

V1

Duvidas? entrar em contato:  
 &Dudas? Ponerse en contacto:  
 Doubts? Get in touch:

Fone: (51) 3635-8839  
[www.kappesberg.com.br](http://www.kappesberg.com.br)

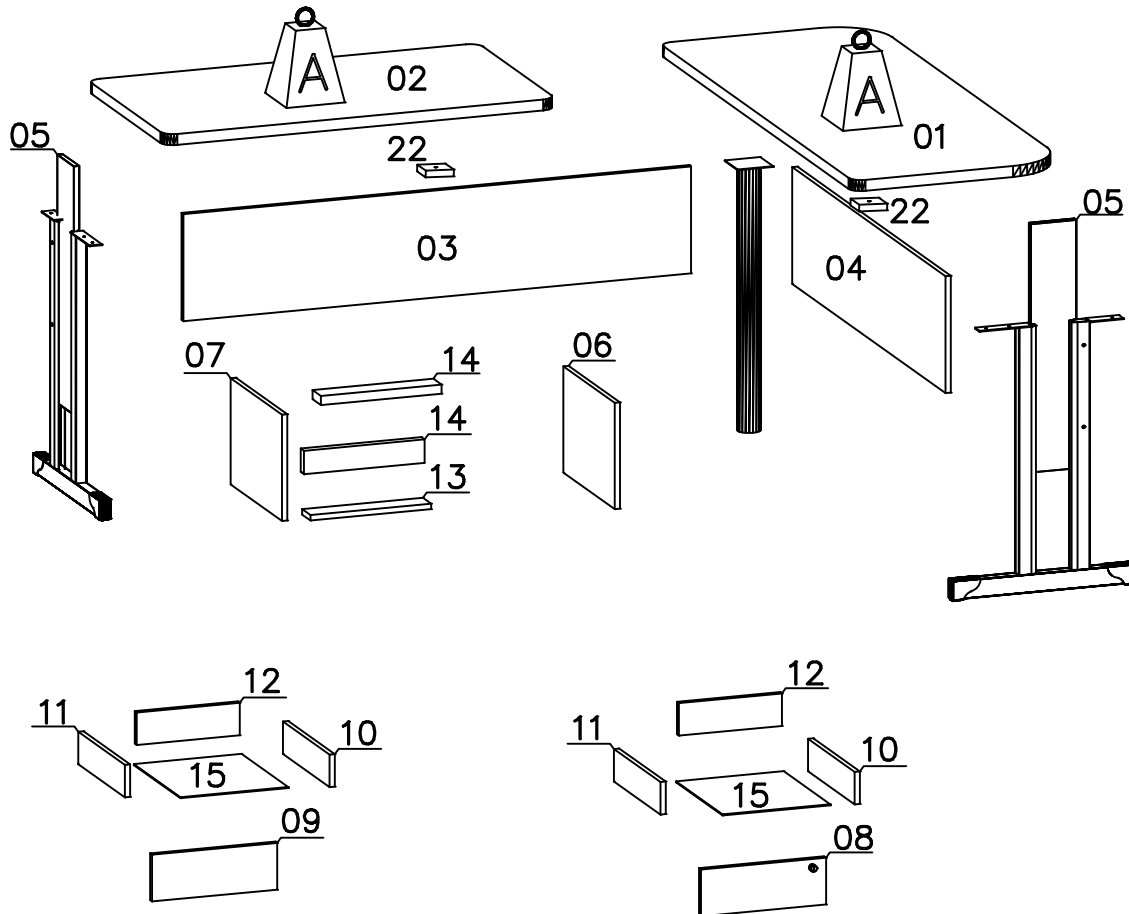
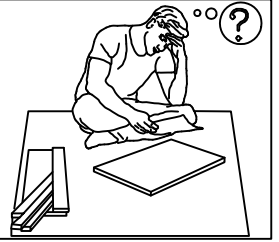

	Kg	lb
A	30	66.14lb

PRÉ-MONTAGEM/ PRE-ASSEMBLE/ PRE ARMADO

1170A

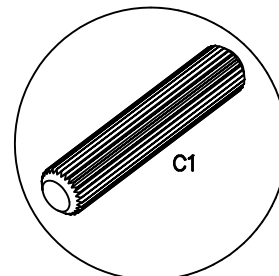
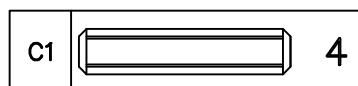
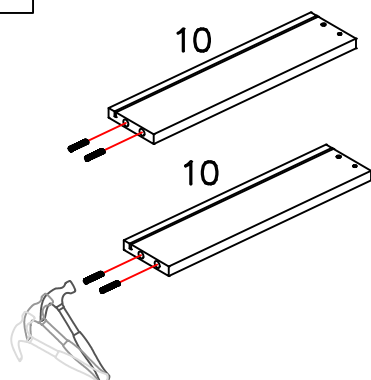
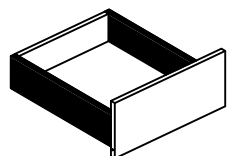
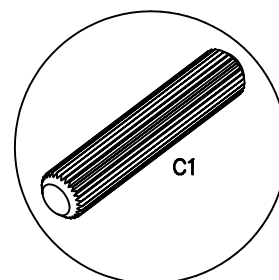
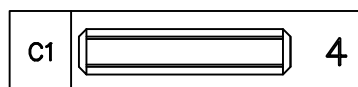
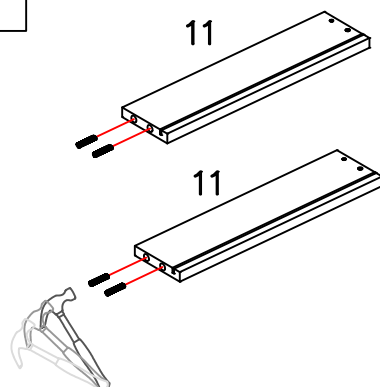
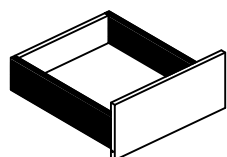
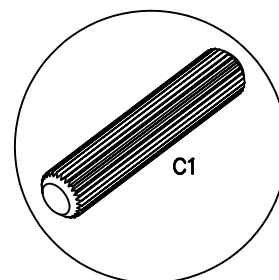
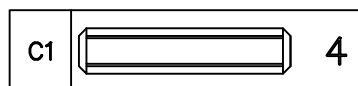
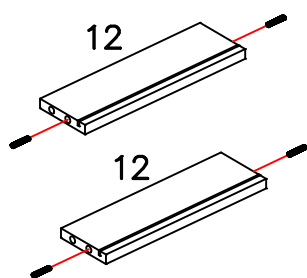
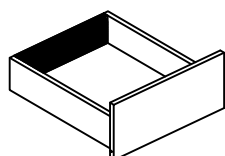
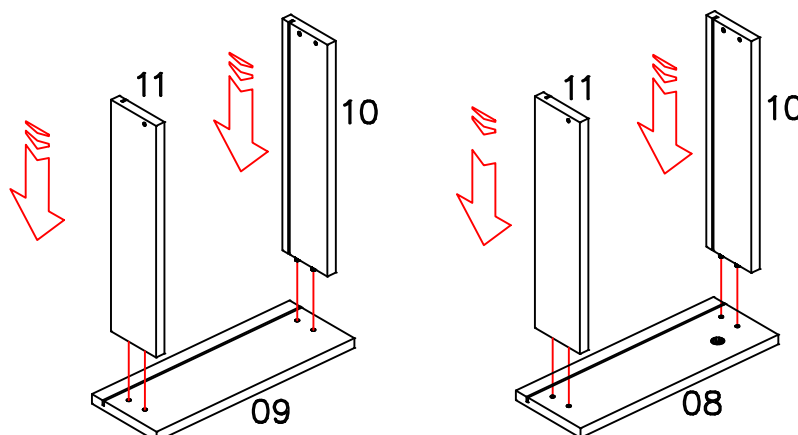
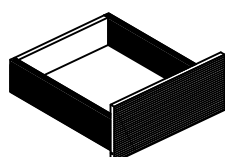
**1A** PASSO/ PASO/ STEP**1B** PASSO/ PASO/ STEP**1C** PASSO/ PASO/ STEP**02** PASSO/ PASO/ STEP

**MONTAGEM/ ASSEMBLE/ ARMADO**

# 1170A

**03 PASSO/ PASO/ STEP**

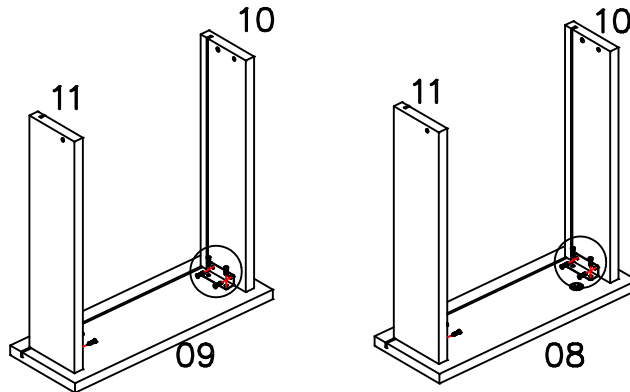
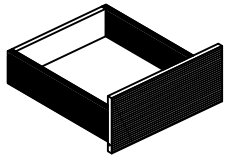

CG		4
PC3		16

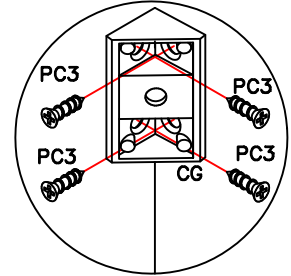

**04 PASSO/ PASO/ STEP**

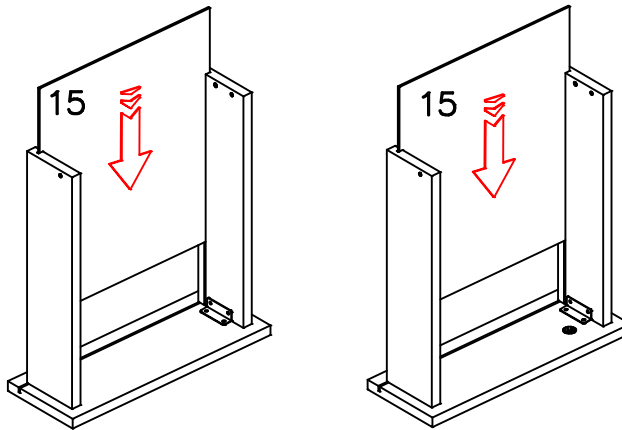
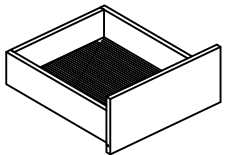

**05 PASSO/ PASO/ STEP**

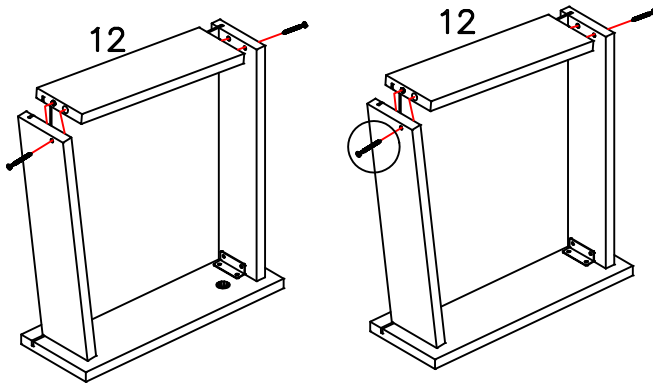
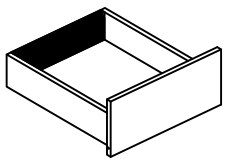

PF7		4
-----	--	---

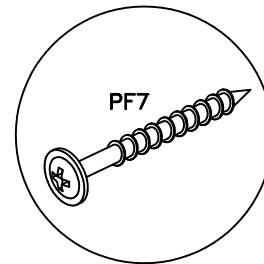

**06 PASSO/ PASO/ STEP**

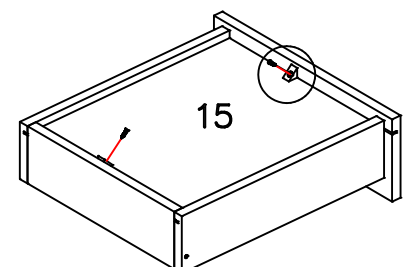
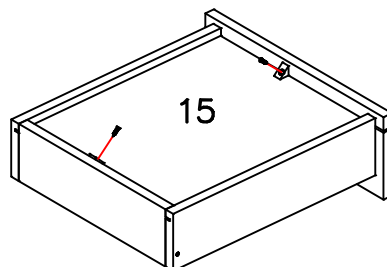
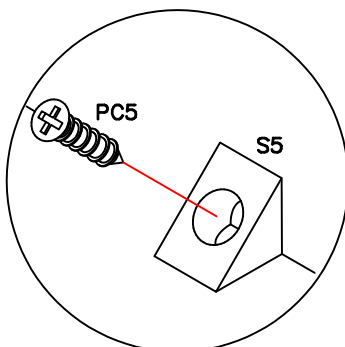
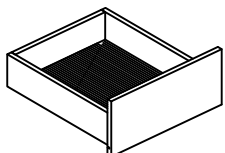



PC5		4
S5		4



# 1170A

## 07 PASSO/ PASO/ STEP

PC3		8
CM1A		2
CM1B		2

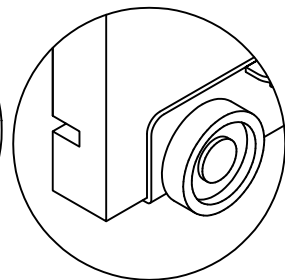
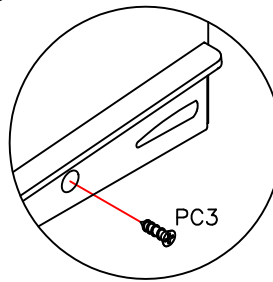
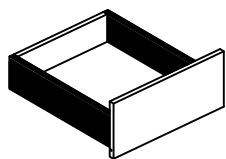
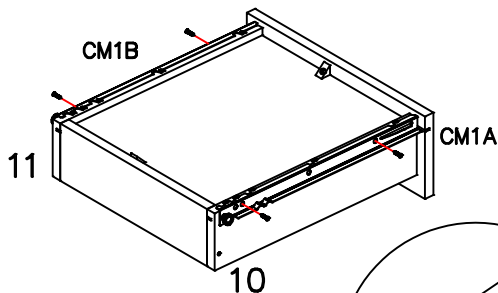
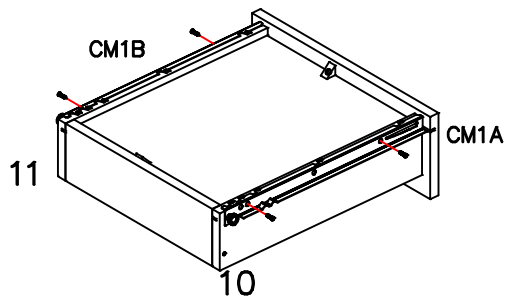

## 08 PASSO/ PASO/ STEP

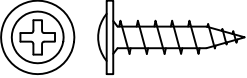
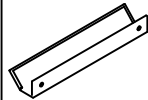
PF4		4
PX		2

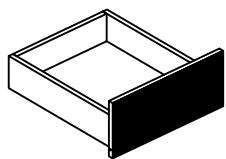
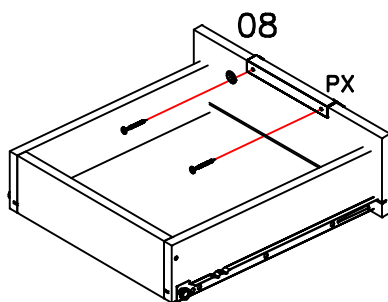
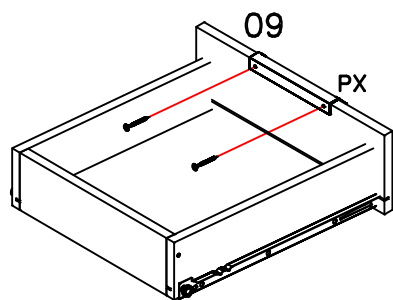

## 09 PASSO/ PASO/ STEP

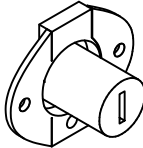
PC3		2
F		1

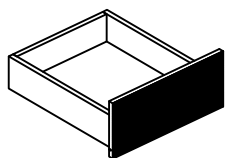
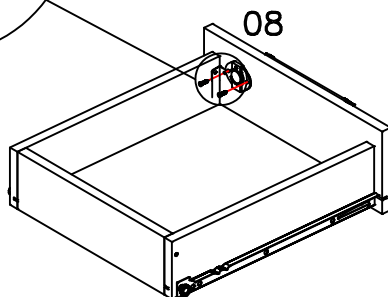
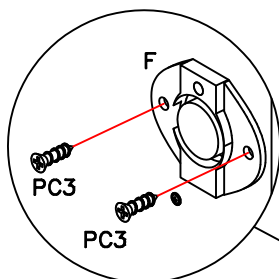

**PRÉ-MONTAGEM/ PRE-ASSEMBLE/ PRE ARMADO**

# 1170A

**10 PASSO/ PASO/ STEP**

Vista detalhada da localização CORRETA do furo no trilho para o parafuso "PC3"

Vista detallada de la ubicación CORRECTA del orificio en el riel para el tornillo "PC3"

Detailed view of CORRECT hole location in the rail for the "PC3" Screw

PC3		8
CM1C		2
CM1D		2

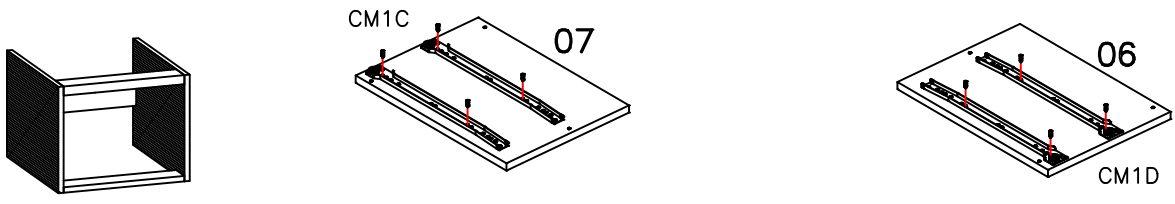
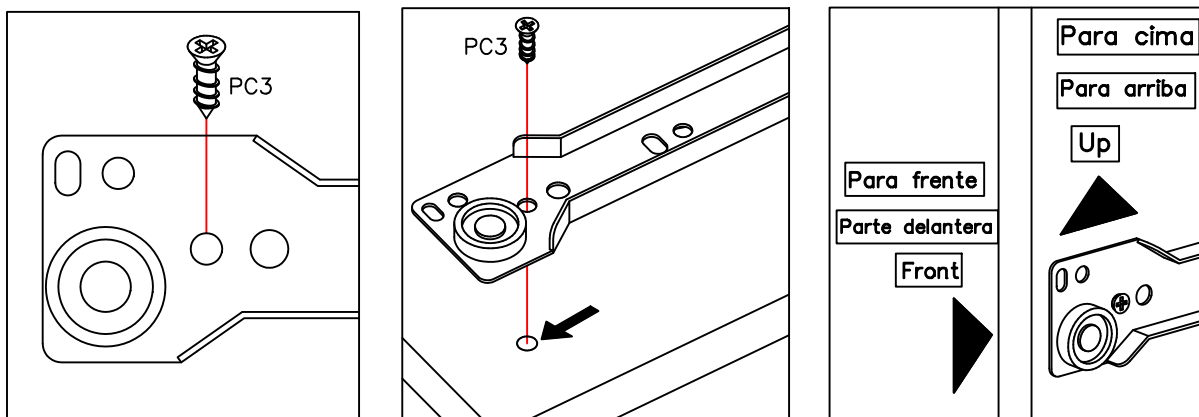

**11 PASSO/ PASO/ STEP**

PF7		6
-----	--	---

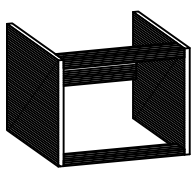
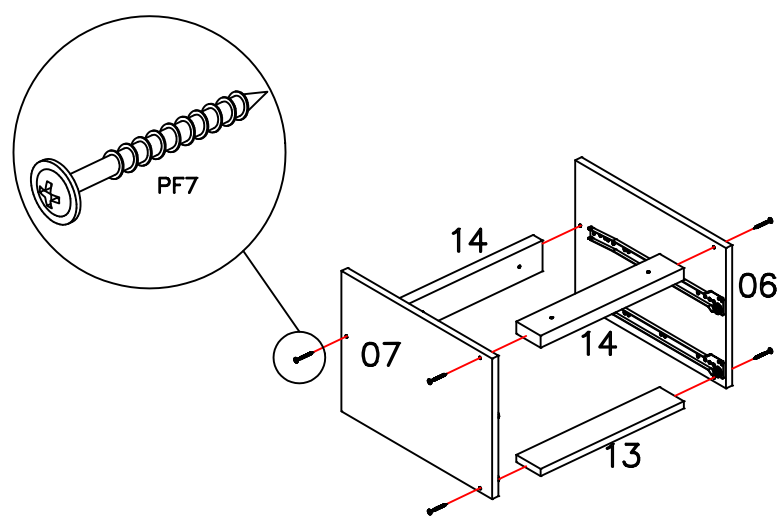

PRÉ-MONTAGEM/ PRE-ASSEMBLE/ PRE ARMADO

1170A

12 PASSO/ PASO/ STEP

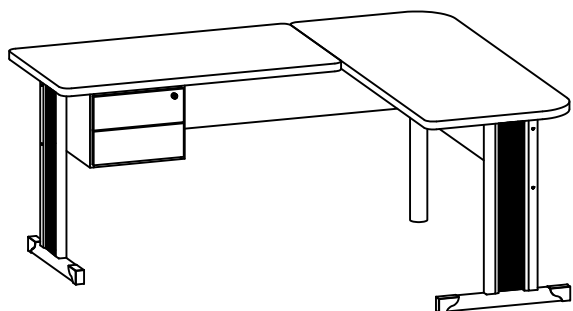
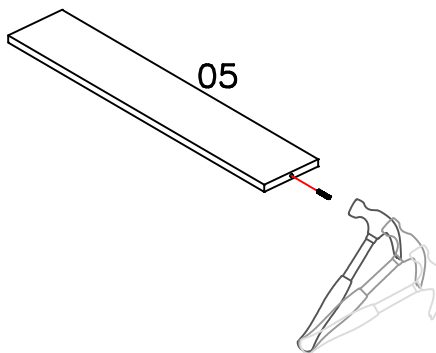
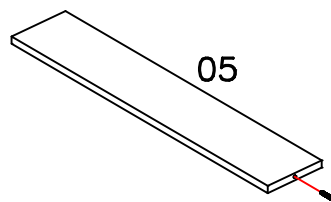
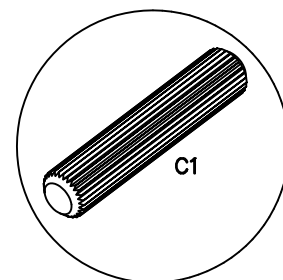
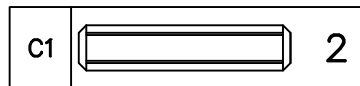

13 PASSO/ PASO/ STEP

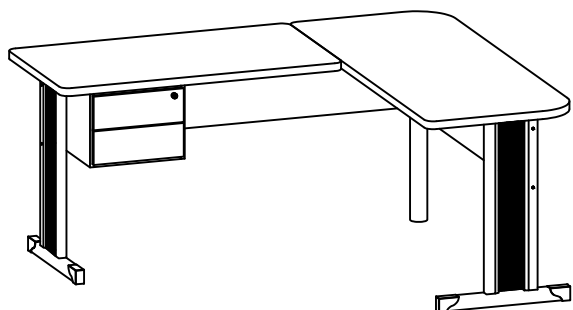
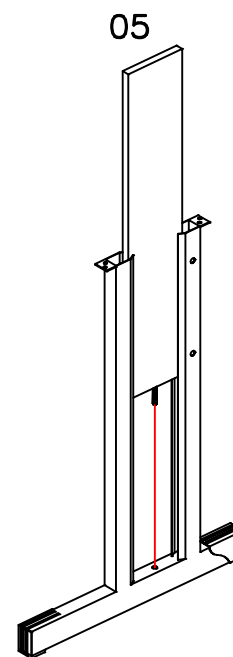
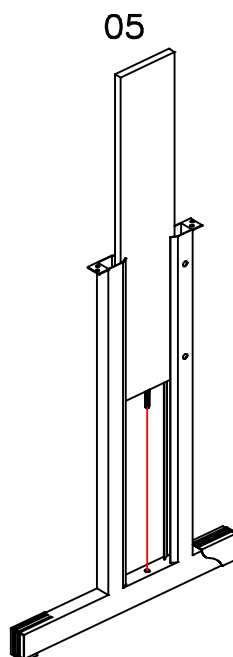
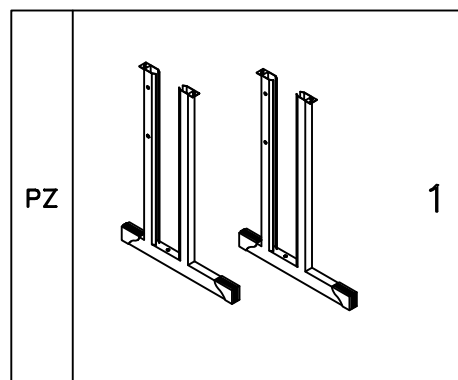

# 1170A

**14 PASSO/ PASO/ STEP**

PE9		4
PE12		4
PF7		2
CZ1		1
CPL		8
PC		1

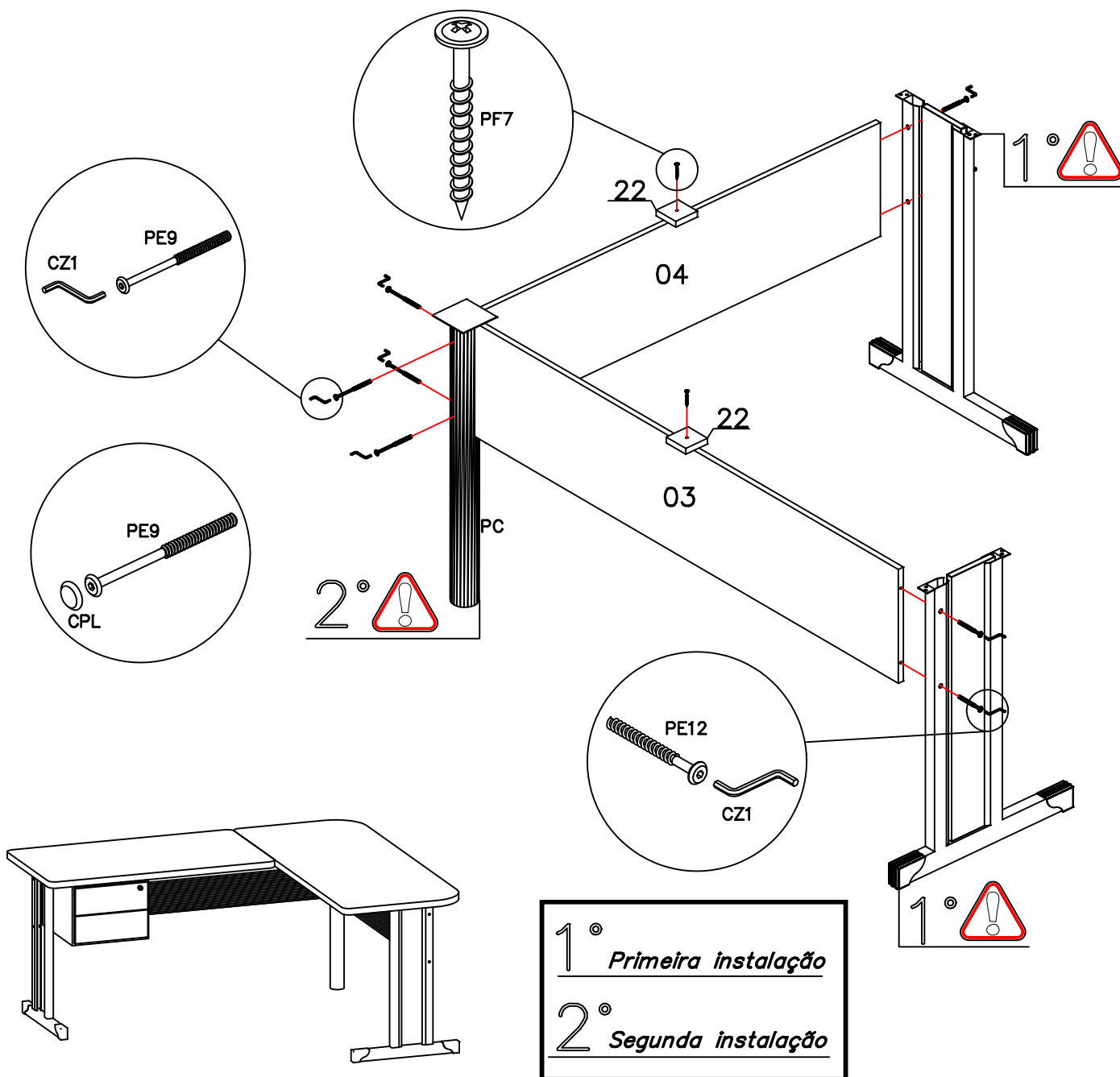

1° *Primeira instalação*

2° *Segunda instalação*

# 1170A

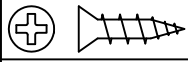
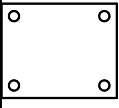
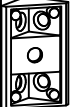

**15** PASSO/ PASO/ STEP

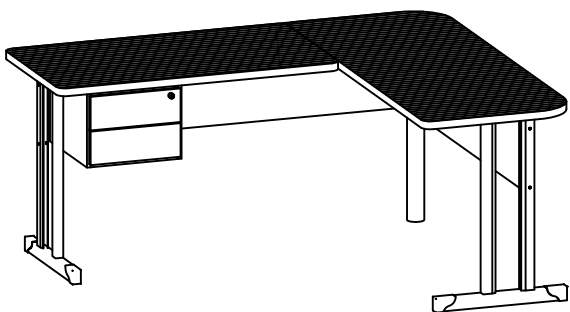
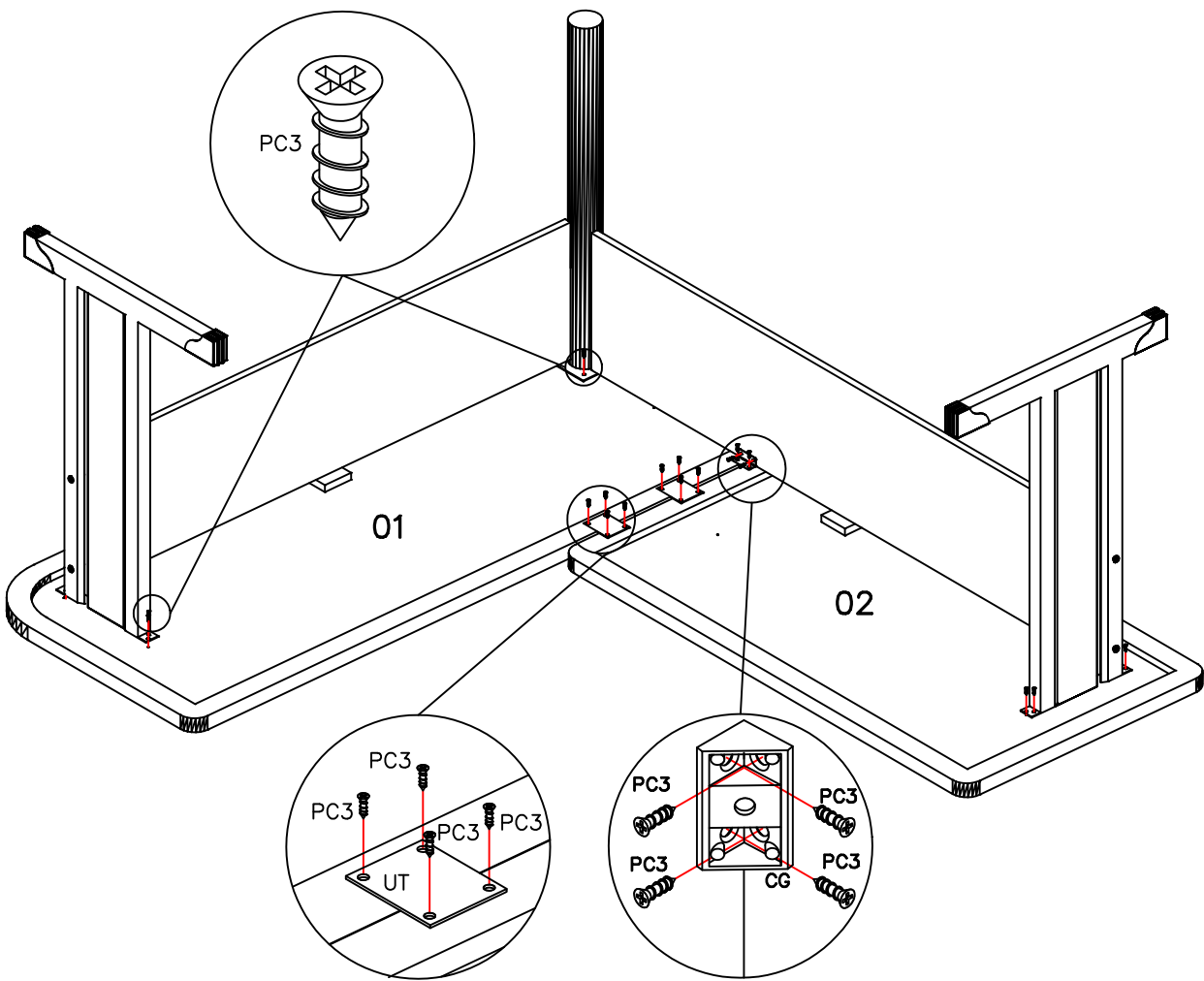
PC3		24
UT		2
CG		1

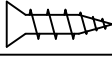

# 1170A

**16** PASSO/ PASO/ STEP

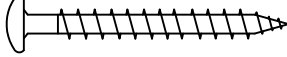
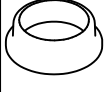
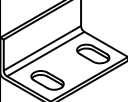
PC3			2
PP6			4
SA2			1
LE			1

