

**610037**

**Armário Wind  
Wind Cabinet  
Armario Wind**

**INSTRUÇÕES DE MONTAGEM:**

- 1- ANTES DE INICIAR O PROCESSO DE MONTAGEM, LEIA E OBSERVE ATENTAMENTE TODAS AS INSTRUÇÕES;
- 2- A MONTAGEM DO PRODUTO DEVERÁ SER EXECUTADA SOBRE A SUPERFÍCIE LIMPA E PLANA (ACONSELHAMOS A UTILIZAÇÃO DA PRÓPRIA EMBALAGEM PARA FERRAR A SUPERFÍCIE DE MONTAGEM, A FIM DE NÃO DANIFICAR O PRODUTO);
- 3- PARA OS PROCEDIMENTOS DE LIMPEZA, UTILIZAR UM PANO LEVEMENTE UMEDECIDO COM ÁGUA E EM SEGUIDA UM PANO SECO;
- 4- NÃO UTILIZE PRODUTOS QUÍMICOS ABRASIVOS;

**ASSEMBLY INSTRUCTIONS:**

- 1- PLEASE READ THESE INSTRUCTIONS COMPLETELY BEFORE STARTING ASSEMBLY;
- 2- THE ASSEMBLY MUST BE EXECUTED ON A FLAT AND CLEAN SURFACE;
- 3- FOR CLEANING PLEASE USE A WATER SEMI WET CLEAN CLOTH FOLLOWING BY A DRY CLEAN CLOTH;
- 4- DO NOT USE ABRASIVES SOLUTIONS;

**INSTRUCCIONES DE MONTAJE:**

- 1- ANTES DE COMENZAR EL PROCESO DE MONTAJE, LEA ATENTAMENTE Y OBSERVE TODAS LAS INSTRUCCIONES;
- 2- EL MONTAJE DEL PRODUCTO DEBERÁ LLEVARSE A CABO SOBRE UNA SUPERFICIE LIMPA Y PLANA (NOSOTROS USAMOS EL PROPIO ENVASE A LA LÍNEA DE LA SUPERFÍCIE DE LA ASAMBLEA, A FIN DE NO DAÑAR EL PRODUCTO);
- 3- PARA LOS PROCEDIMIENTOS PARA LA LIMPIEZA, UTILICE UN PAÑO HUMEDECIDO CON AGUA, Y LUEGO UN PAÑO SECO;





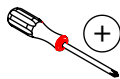
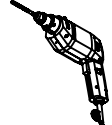

**LISTA DE PEÇAS / PIECES LIST / LISTA DE PIEZAS**

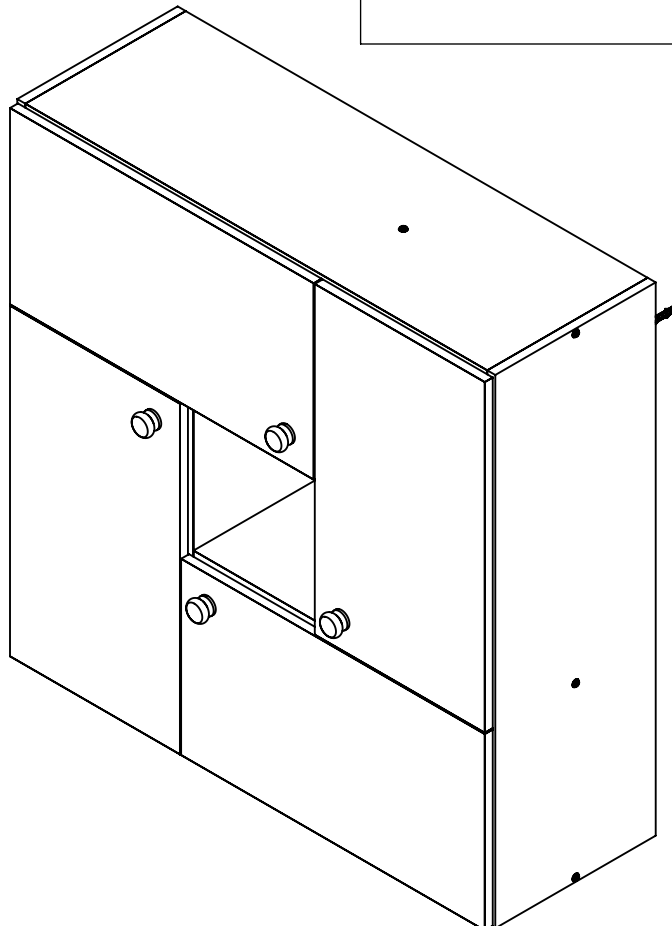
COD.	DESCRIÇÃO / DESCRIPTION / DESCRIPCIÓN	QUANT.
1	Lateral / Side pannel / Lateral	2
2	Base / Base Pannel / Base	2
3	Divisórias / Dividing Panel / Divisoria	4
4	Costas / Back Panel / Trasera	1
5	Porta horizontal / Horizontal door / Puerta horizontal	2
6	Porta vertical / Vertical door / Puerta vertical	2

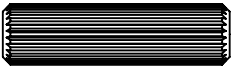
**FERRAMENTAS NECESSÁRIAS / REQUIRED TOOLS / HERRAMIENTAS NECESARIAS**

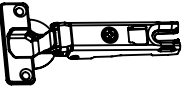
FERRAMENTA / TOOL / HERRAMIENTA	IMAGEM / IMAGE
Chave Phillips / Phillips Screwdriver / Destornillador Phillips	
Furadeira / Drill / Taladro	

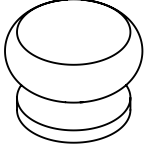

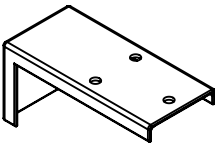
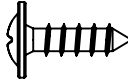
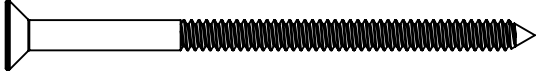
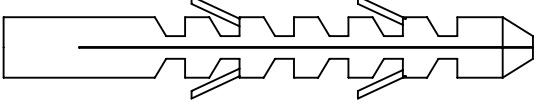
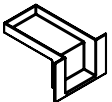
COD.	DESCRIÇÃO / DESCRIPTION / DESCRIPCIÓN	QUANT.	IMAGEM / IMAGE
A	Cavilha / Dowel / Clavija 8 x 30	28	
B	Parafuso / Screw / tornillo M4 x 40	12	
C	Calço de dobradiça / Hinge Base-plate / Placa de Montaje	8	
D	Caneco de dobradiça / Hinge Cup / Copa de bisagra	8	
E	Parafuso / Screw / tornillo M4 x 16	24	
F	Cola / Glue / Pegamento	1	
G	Tapa Furos / Adhesive Cap / Capa Adhesiva	12	
H	Puxador / Handle / Tirador	4	
I	Parafuso / Screw / tornillo M4 x 35	4	
J	Chapa de fixação / Fixing Plate / Placa de Fijación	2	
K	Parafuso flangeado/ Screw / tornillo 4 x 14	6	
L	Parafuso / Screw / tornillo M6 x 70	2	
M	Bucha / wall anchor / Taco	2	
N	Capa para chapa de fixação / Fixing Plate Cover / Tapa de Placa de Fijación	2	

# 1

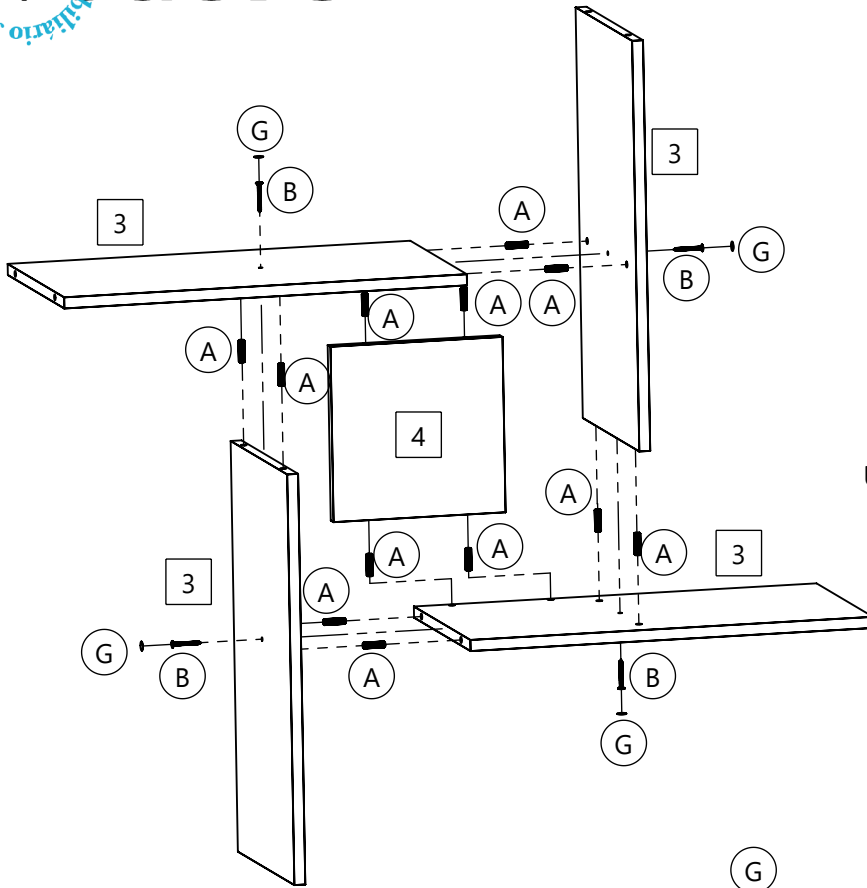

Use cola em todas as cavilhas

Use glue with the dowels

Usar pegamento en las clavijas

# 2

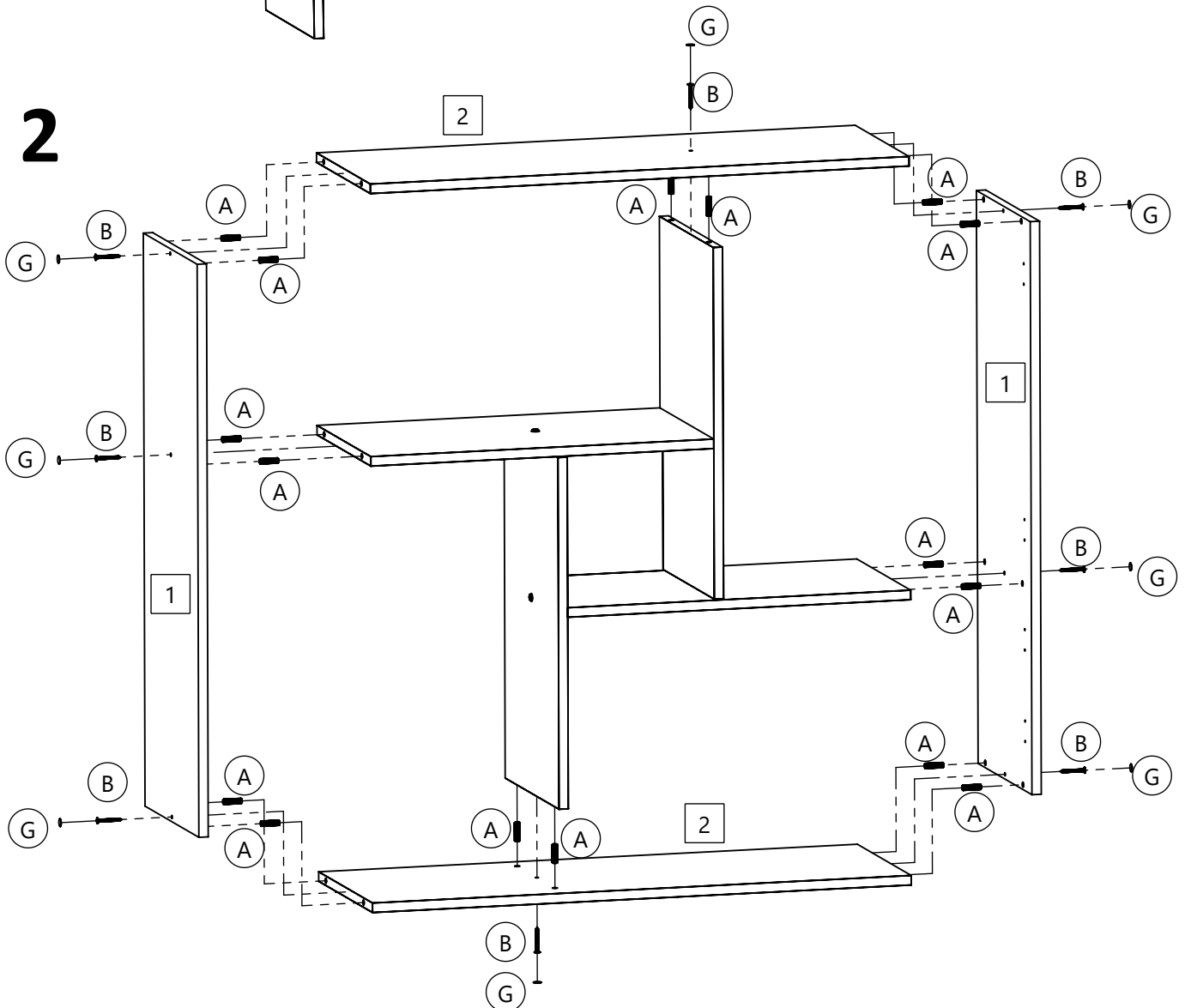

3

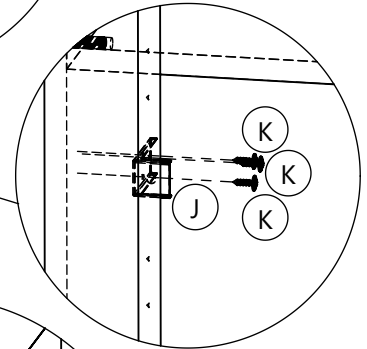
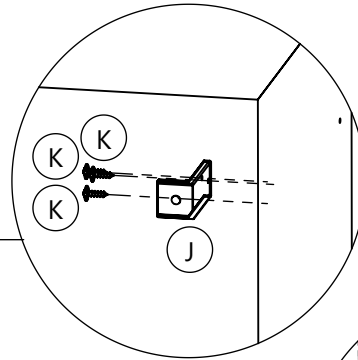
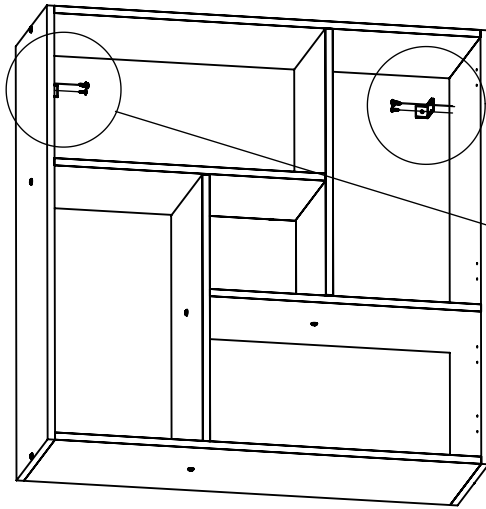

4

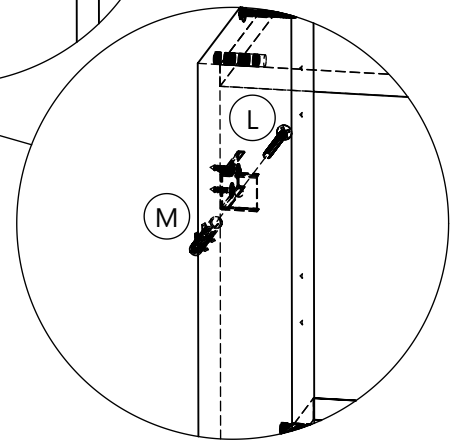
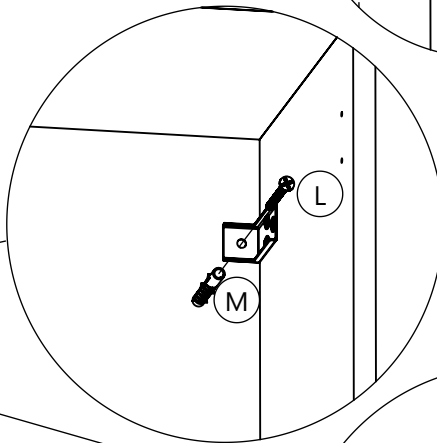
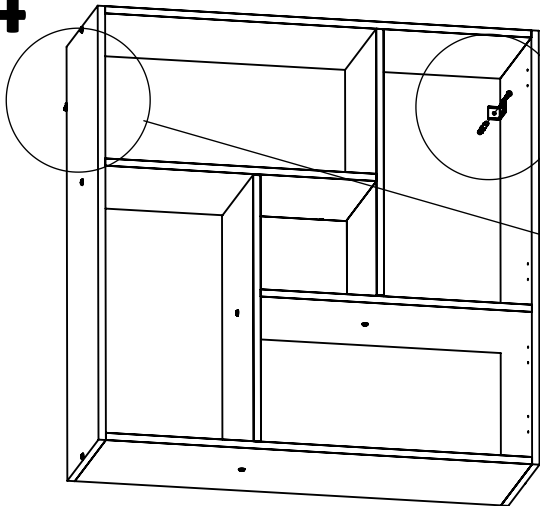

5

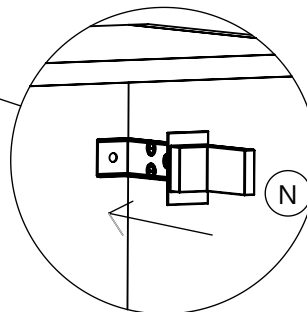
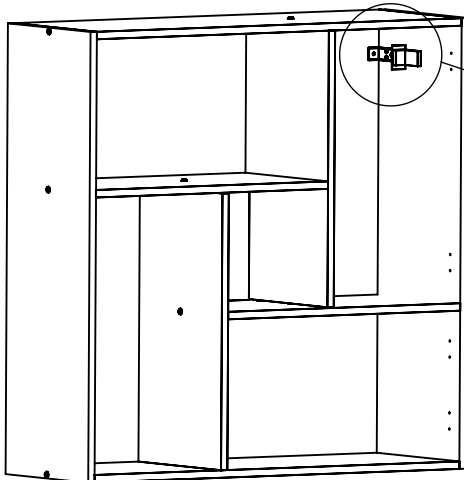

**6** 2x

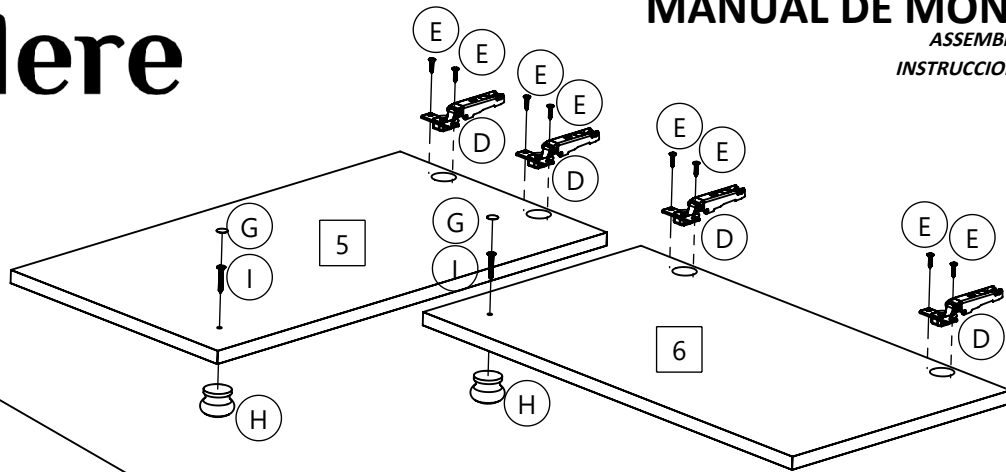

**7**

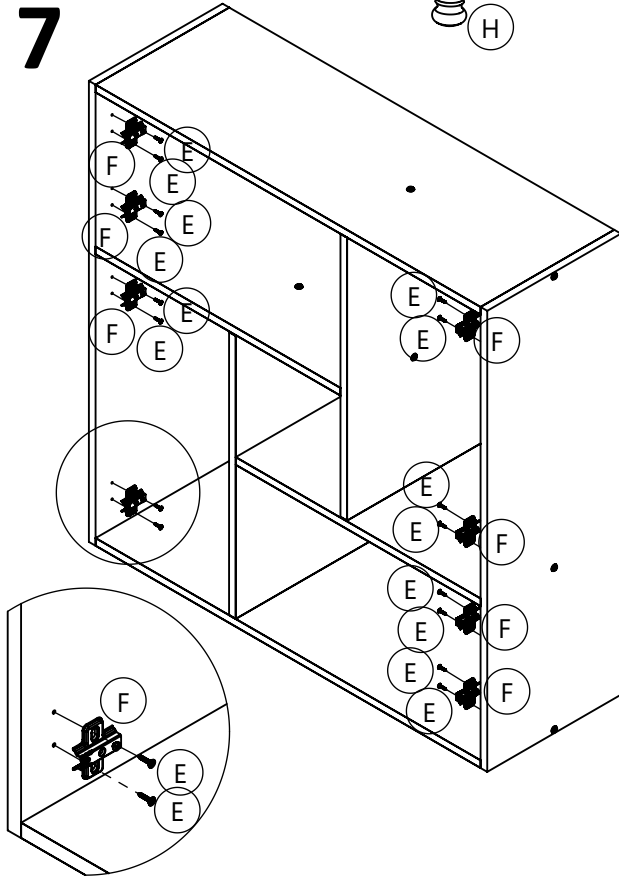

**8**

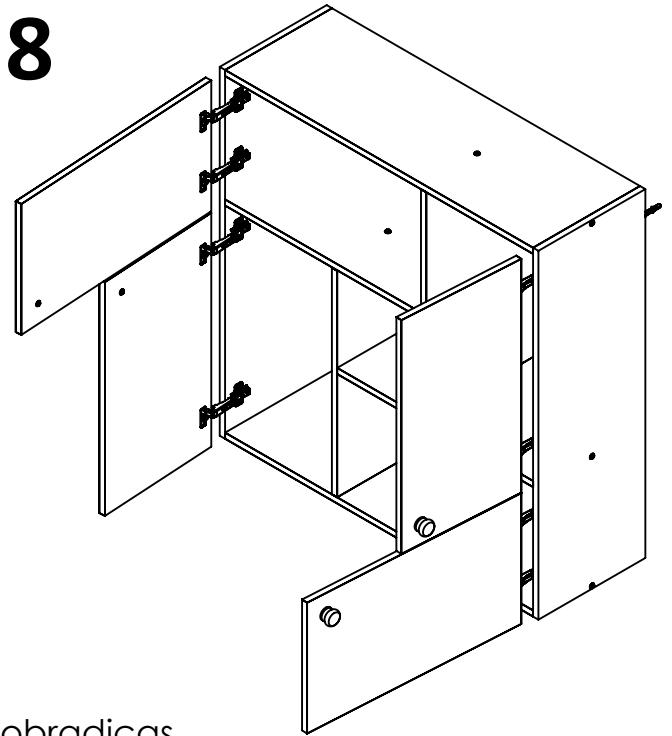

**9**

Ajuste as dobradiças

Adjust the hinges

Ajuste las bisagras

